



US00D643341S

(12) **United States Design Patent**
Uchiyama

(10) **Patent No.:** **US D643,341 S**

(45) **Date of Patent:** **** Aug. 16, 2011**

(54) **MOTORCYCLE**

(75) Inventor: **Shigeru Uchiyama**, Hamamatsu (JP)

(73) Assignee: **Suzuki Motor Corporation**,
Shizuoka-Pref. (JP)

(**) Term: **14 Years**

(21) Appl. No.: **29/365,592**

(22) Filed: **Jul. 12, 2010**

(30) **Foreign Application Priority Data**

Jan. 12, 2010 (JP) 2010-000543

(51) **LOC (9) Cl.** **12-11**

(52) **U.S. Cl.** **D12/110**

(58) **Field of Classification Search** D12/110;

180/219, 220, 225, 229

See application file for complete search history.

(56) **References Cited**

U.S. PATENT DOCUMENTS

D384,601 S	10/1997	Hiruma et al.	
D385,226 S	10/1997	Mogi et al.	
D387,017 S	12/1997	Wakita et al.	
D392,601 S	3/1998	Ban et al.	
D394,027 S	5/1998	Ban et al.	
D395,621 S	6/1998	Nishino	
D419,922 S	2/2000	Yamase et al.	
D439,868 S	4/2001	Sugimoto	
D440,189 S	4/2001	Ban et al.	
D470,799 S	2/2003	Yamaguchi	
D496,309 S *	9/2004	Fukumoto et al.	D12/110
D504,844 S *	5/2005	Sasanami	D12/110
D513,481 S	1/2006	Lin	
D522,925 S	6/2006	Nishino	
D523,783 S	6/2006	Sugimoto	
D525,919 S	8/2006	Sugimoto	
D572,629 S	7/2008	Kawagishi	

D581,840 S	12/2008	Ichihara et al.	
D583,714 S	12/2008	Ichihara et al.	
D588,504 S	3/2009	Kawagishi	
D590,302 S	4/2009	Tanaka et al.	
D591,204 S *	4/2009	Matsuzawa	D12/110
D597,449 S *	8/2009	Nagao	D12/110
D604,204 S	11/2009	Uchiyama	
D610,044 S	2/2010	Sugimoto	

* cited by examiner

Primary Examiner — Philip S Hyder

Assistant Examiner — Linda G. Brooks

(74) *Attorney, Agent, or Firm* — Lando & Anastasi, LLP

(57) **CLAIM**

The ornamental design for a motorcycle, as shown and described.

DESCRIPTION

FIG. 1 is a front elevational view of the motorcycle according to my new design.

FIG. 2 is a rear elevational view.

FIG. 3 is a top plan view.

FIG. 4 is a bottom plan view.

FIG. 5 is a right side elevational view of the motorcycle of FIG. 1.

FIG. 6 is a left side elevational view.

FIG. 7 is a front perspective view as seen from the right side of FIG. 1.

FIG. 8 is a rear perspective view as seen from the right side of FIG. 1.

FIG. 9 is a front perspective view as seen from the left side of FIG. 1; and,

FIG. 10 is a rear perspective view as seen from the right side of FIG. 1.

The portions of the motorcycle shown in broken lines form no part of the claimed design.

1 Claim, 10 Drawing Sheets

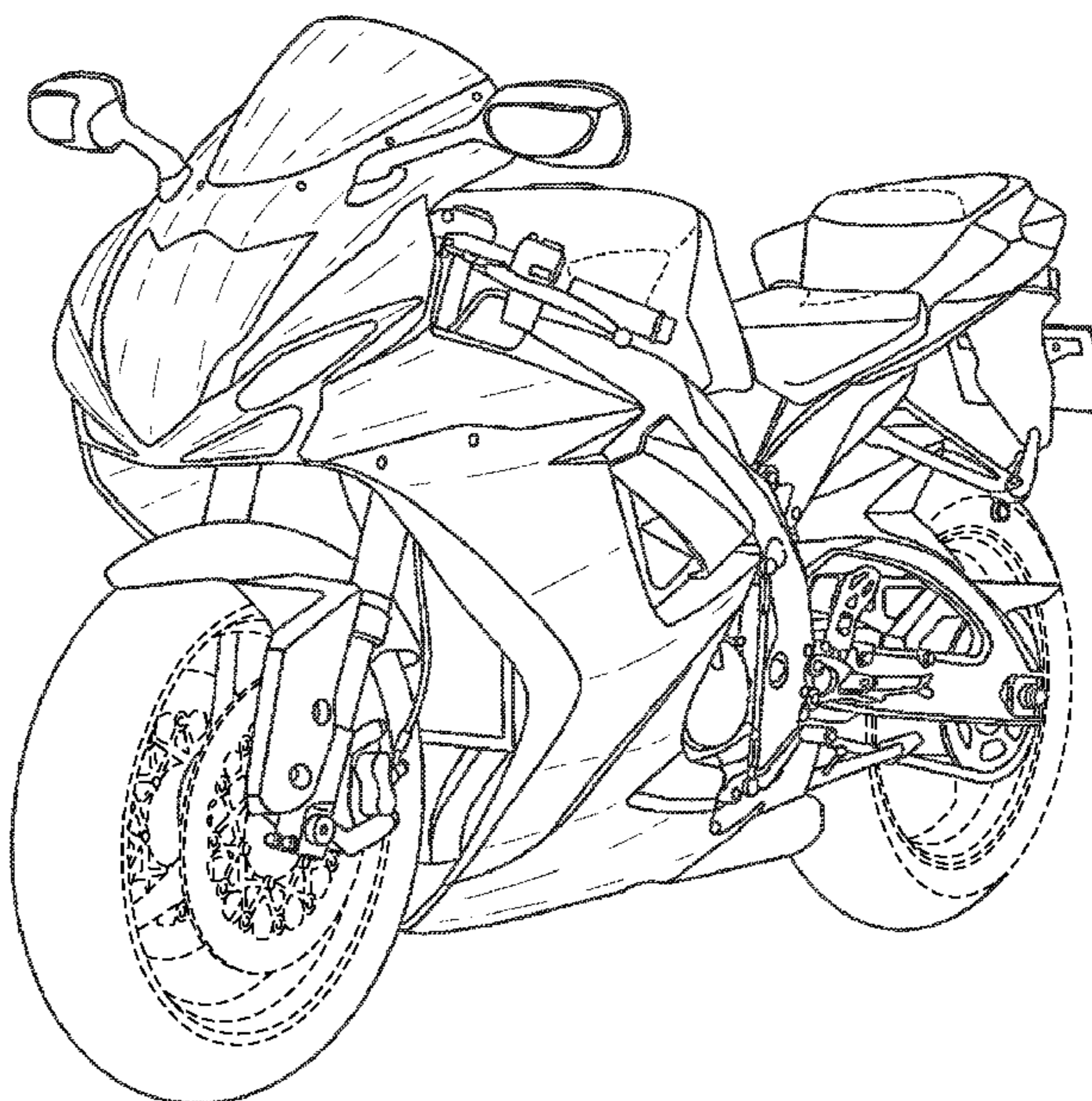
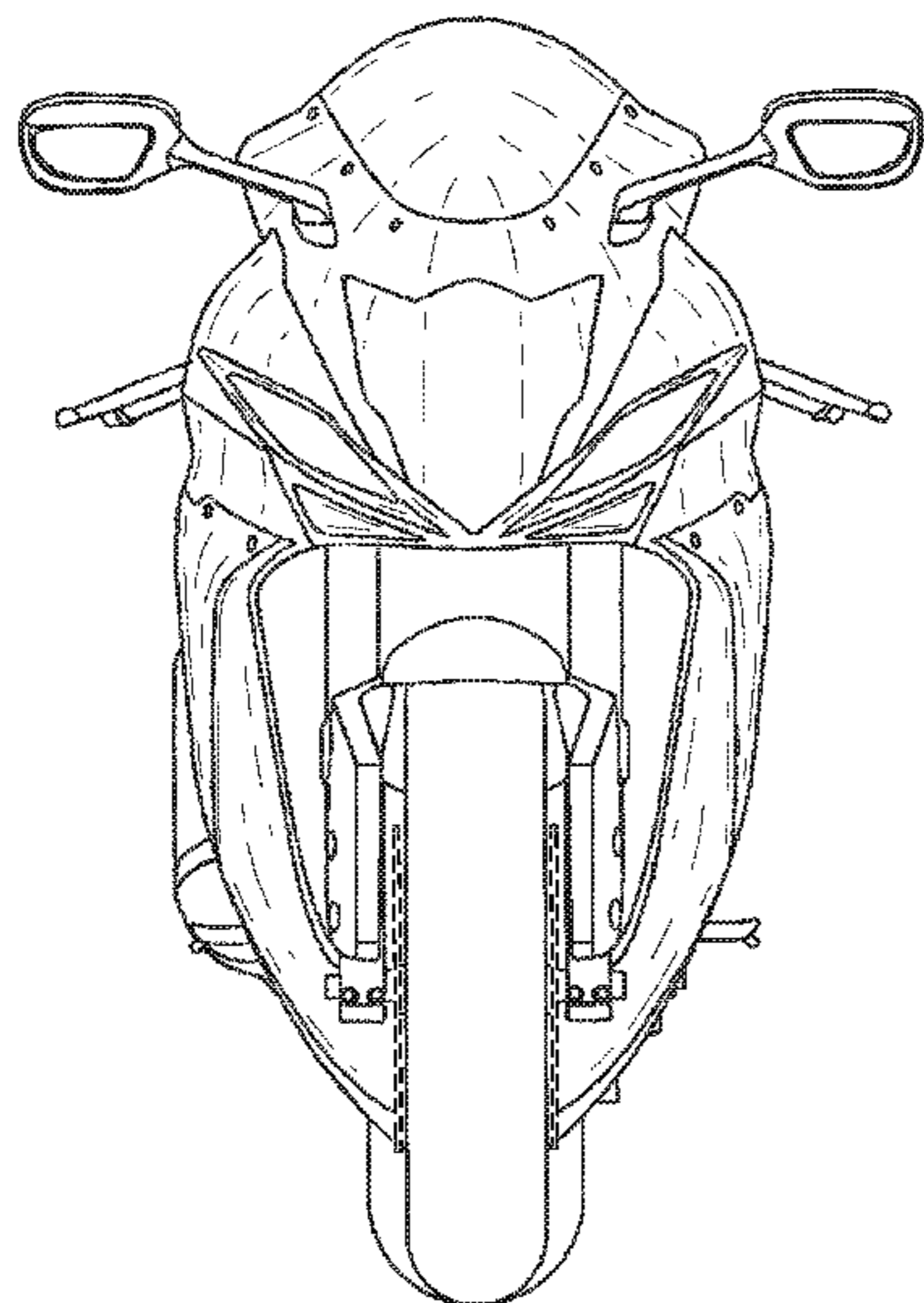

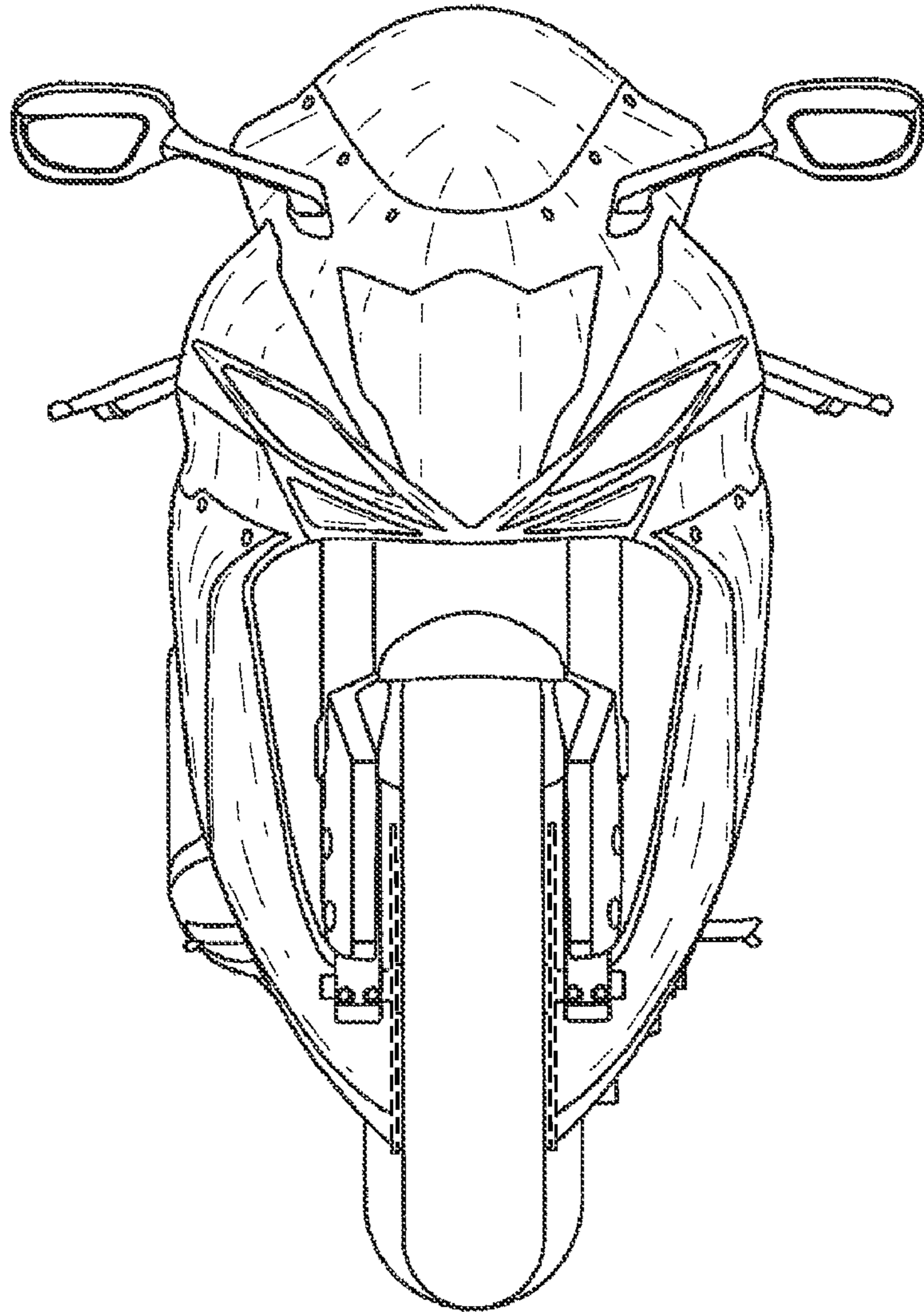

FIG. 1

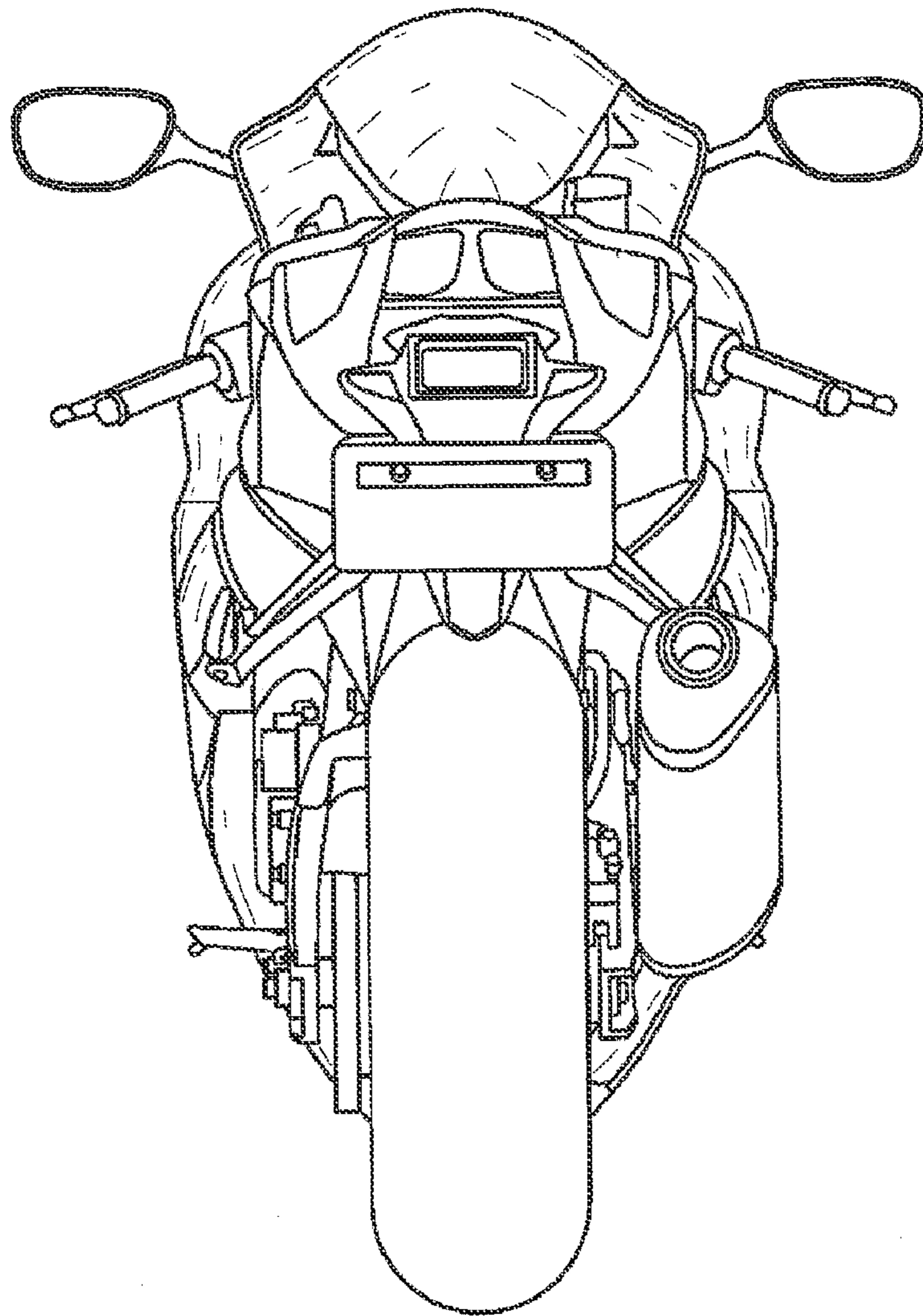

FIG. 2

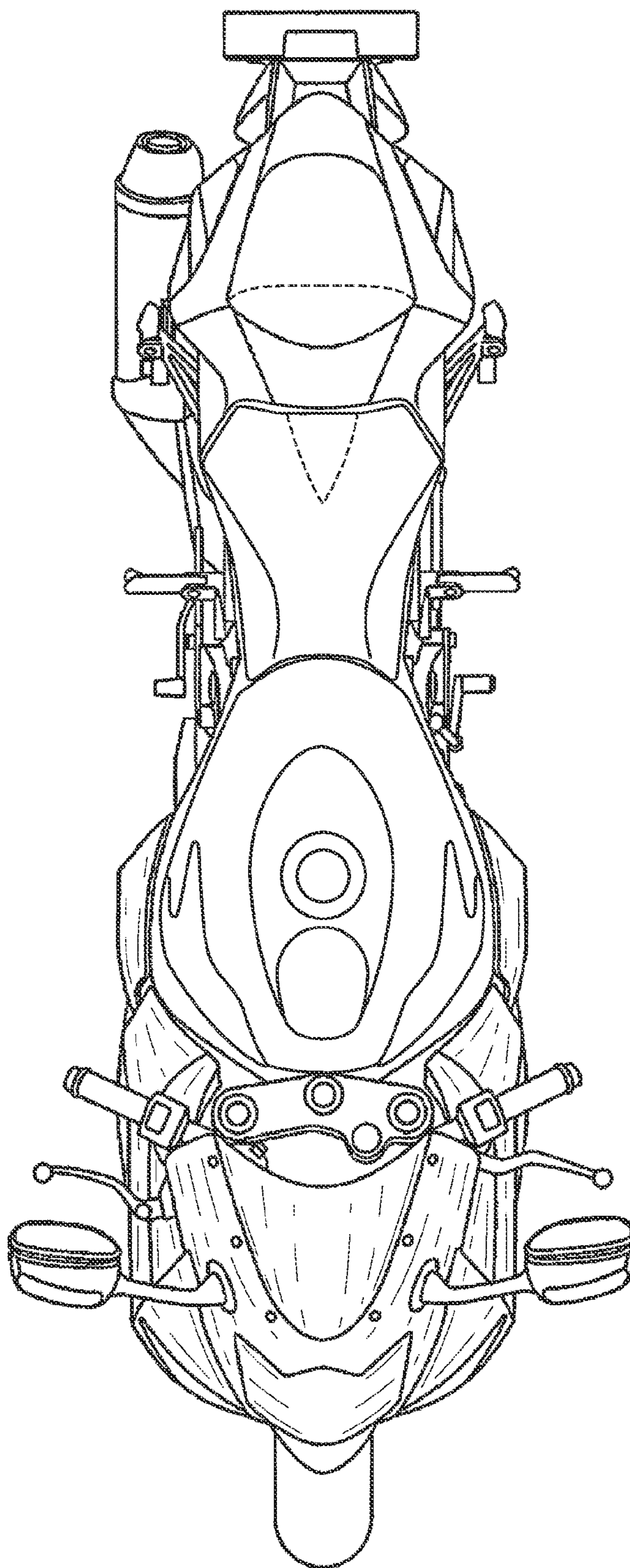

FIG. 3

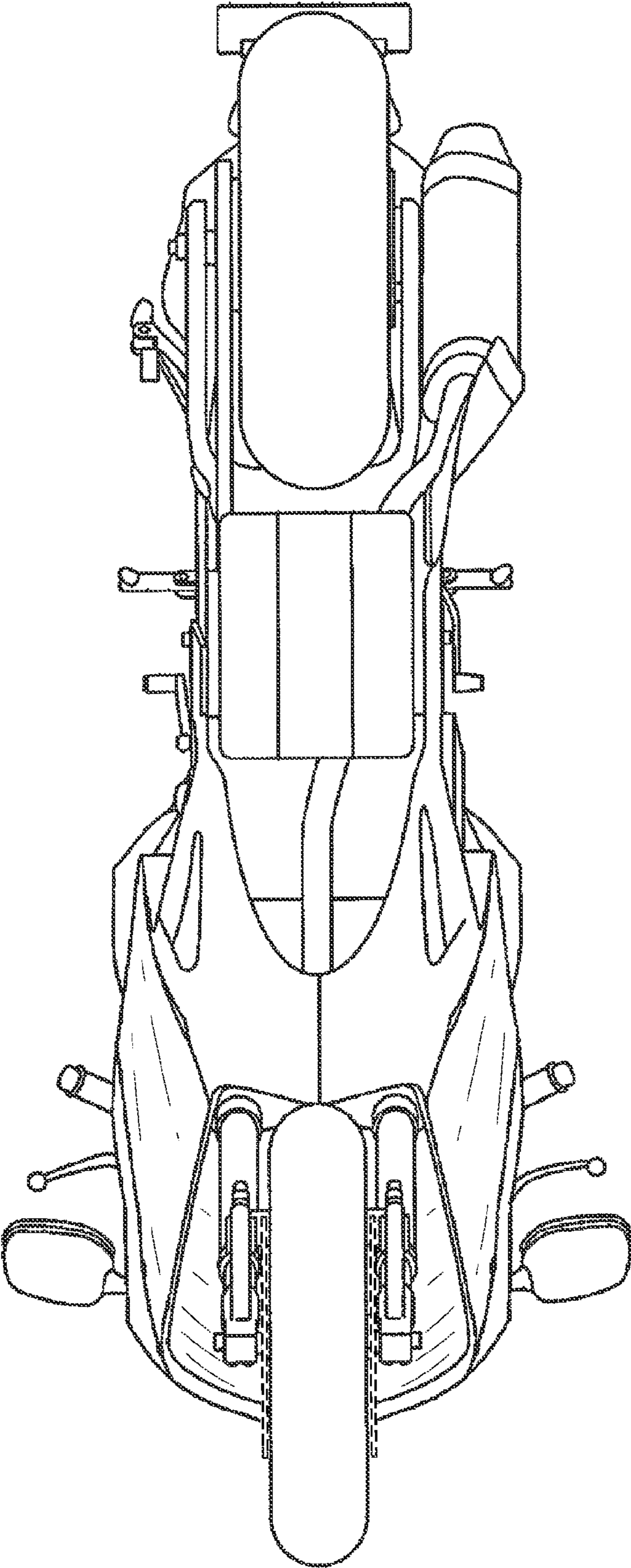

FIG. 4

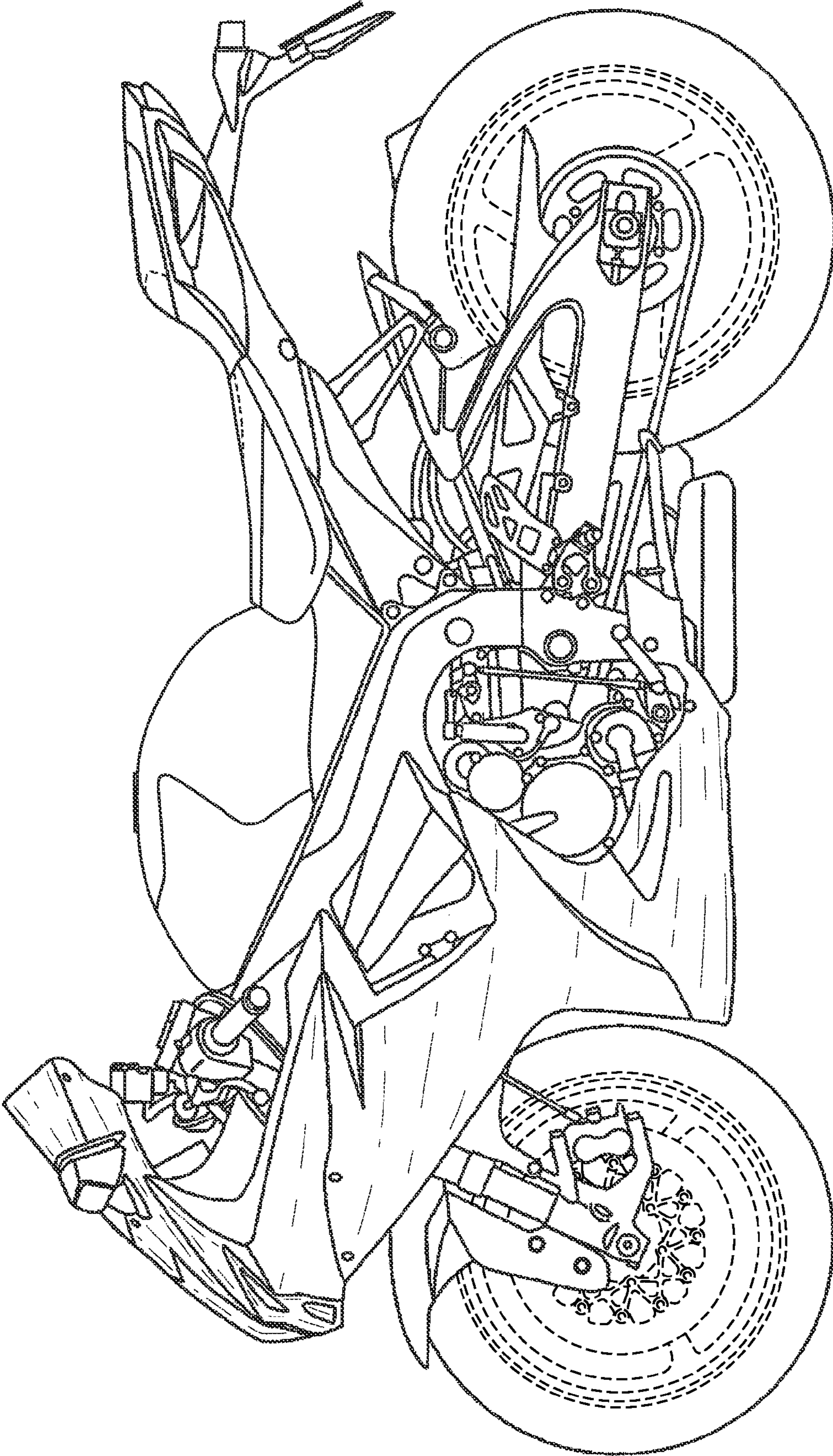

FIG. 5

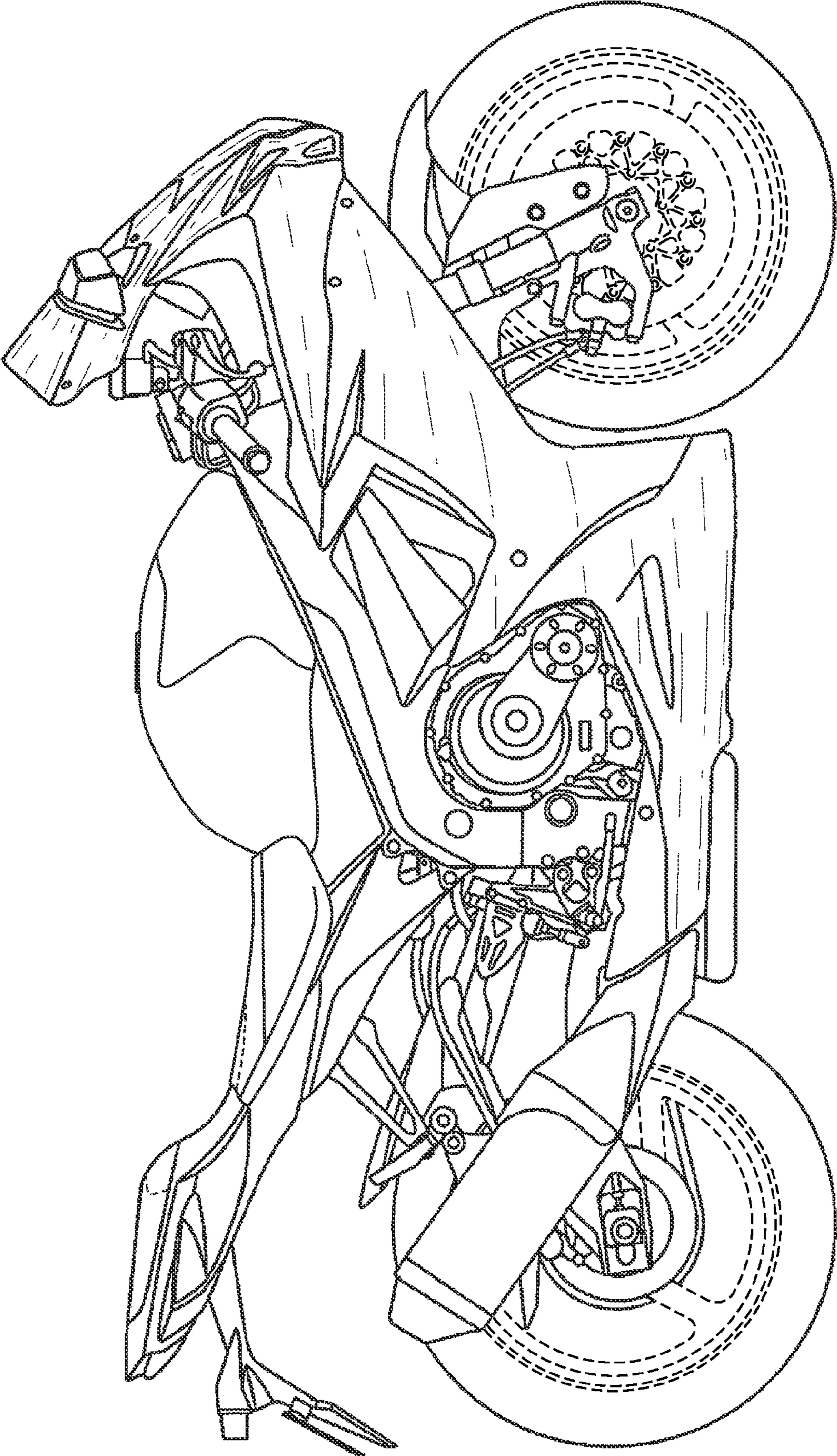

FIG. 6

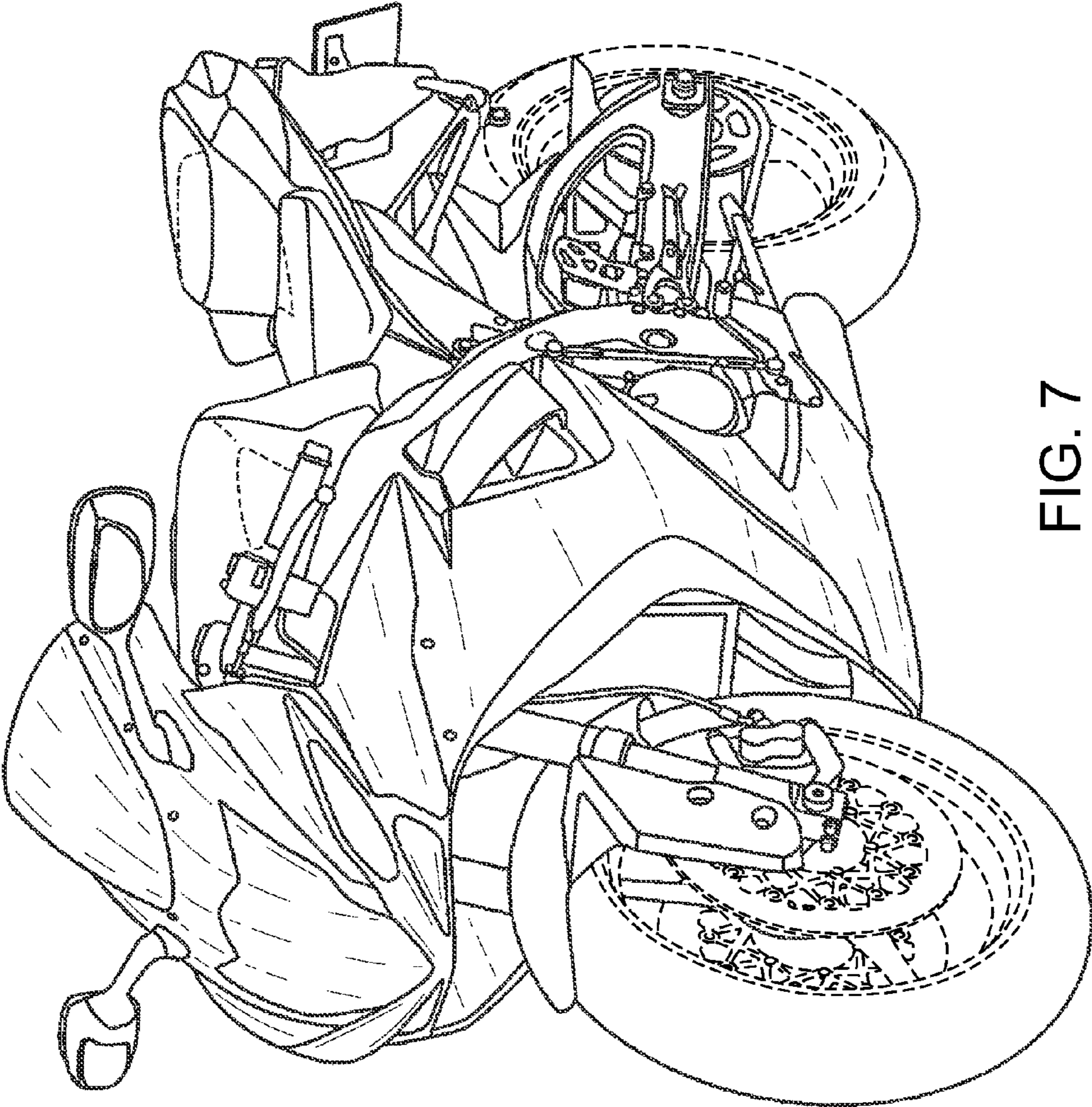

FIG. 7

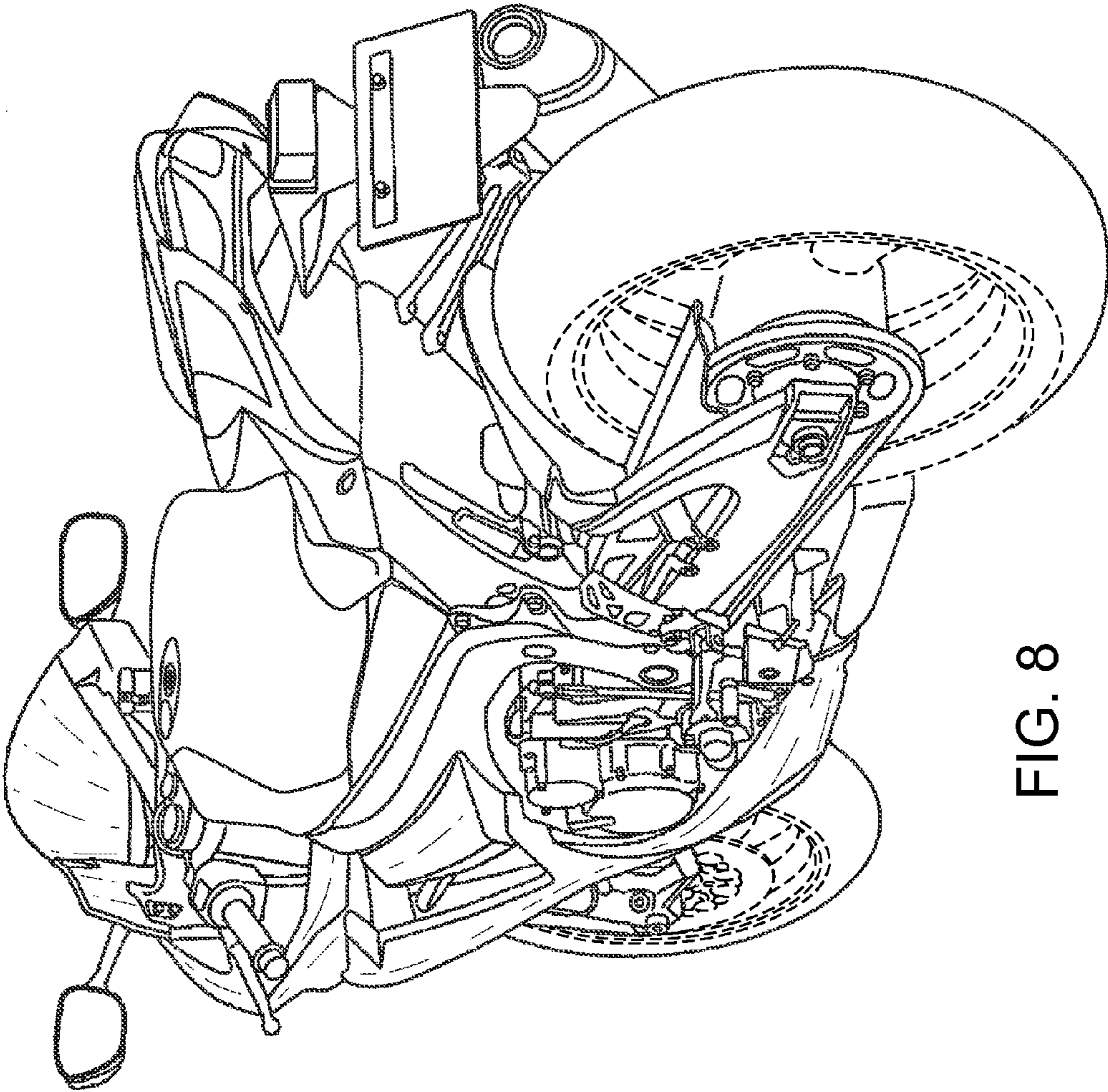

FIG. 8

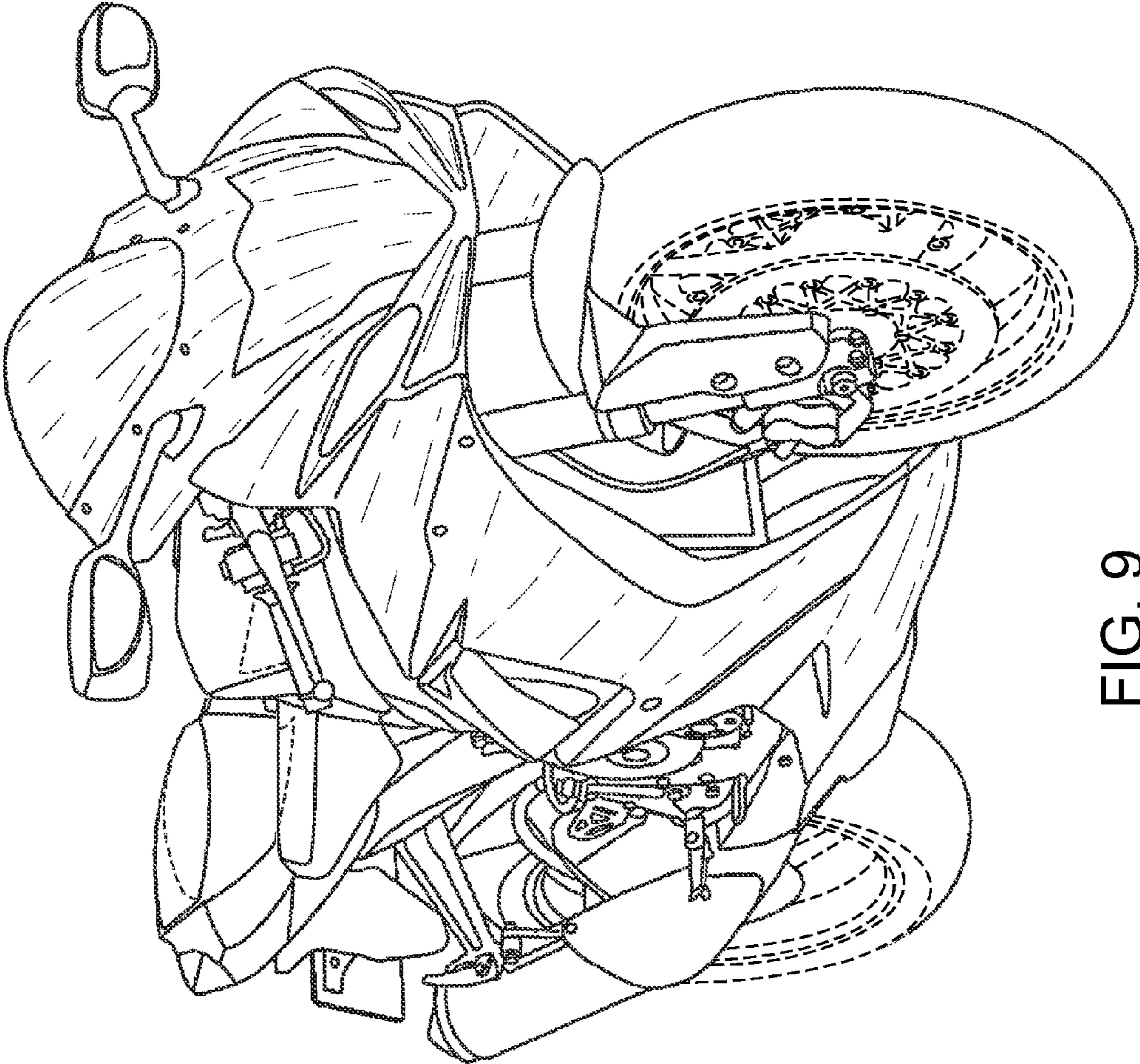

FIG. 9

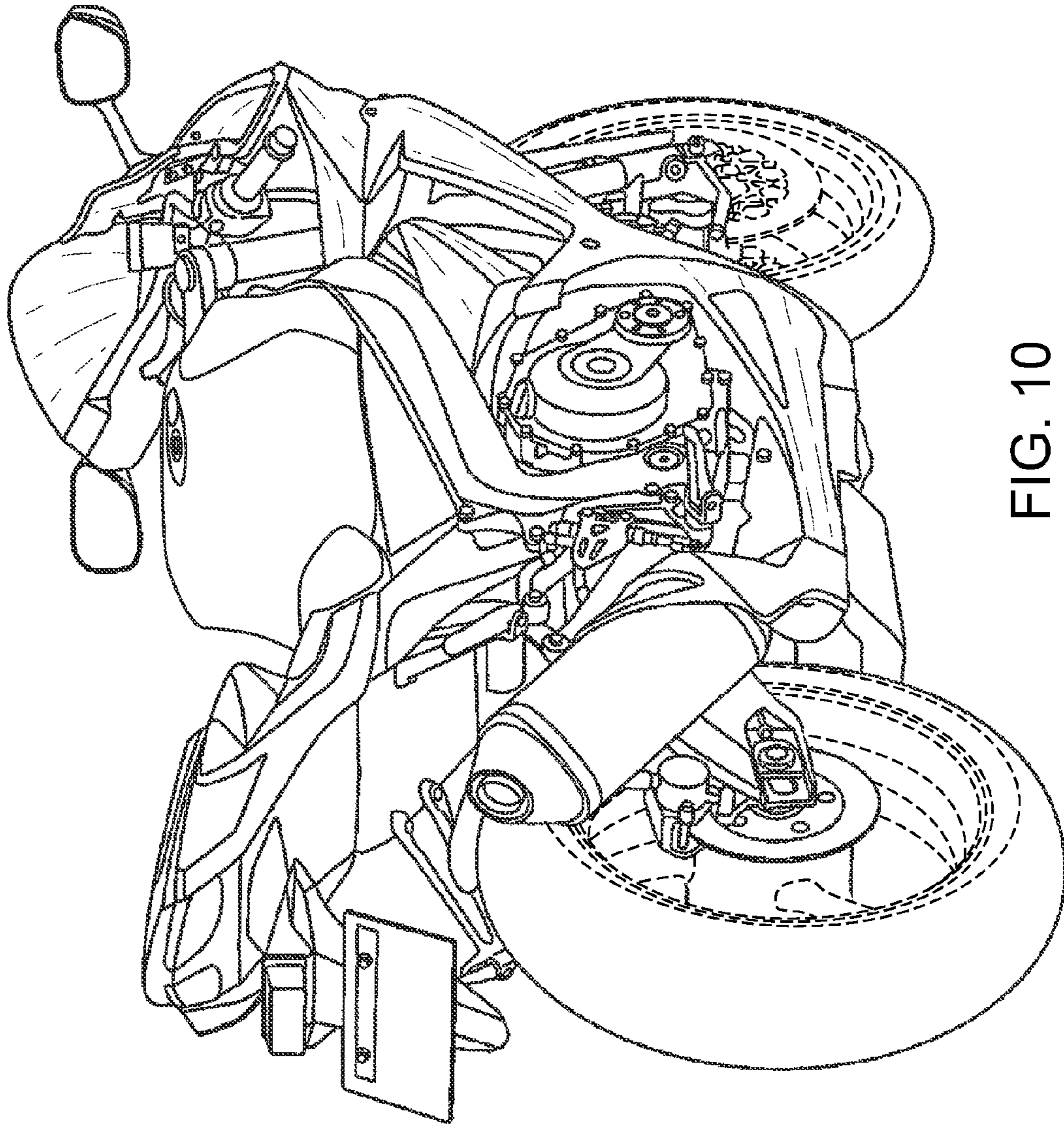

FIG. 10