



US00D643246S

(12) **United States Design Patent**
Gilbert

(10) **Patent No.:** **US D643,246 S**

(45) **Date of Patent:** **** Aug. 16, 2011**

- (54) **HANDLE FOR AN INSULATED BOTTLE**
- (75) Inventor: **Tyler Sean Gilbert**, Bellevue, WA (US)
- (73) Assignee: **Pacific Market International, LLC**,
Seattle, WA (US)
- (**) Term: **14 Years**
- (21) Appl. No.: **29/378,148**
- (22) Filed: **Oct. 29, 2010**

D309,568 S	7/1990	Beton	
4,966,303 A *	10/1990	Jones	220/741
D314,888 S	2/1991	Mano et al.	
D321,628 S	11/1991	Kobayashi et al.	
D329,385 S	9/1992	Machado	
D354,915 S	1/1995	Schneider et al.	
D360,113 S	7/1995	Takahashi	
D378,652 S	4/1997	Yamanaka et al.	
D379,742 S	6/1997	Enomota et al.	
D379,743 S	6/1997	Enomota et al.	
D398,236 S	9/1998	Huang	
D411,716 S	6/1999	Besser et al.	
D416,448 S	11/1999	Webb et al.	
D422,455 S	4/2000	Kato	

(Continued)

Related U.S. Application Data

- (62) Division of application No. 29/345,052, filed on Oct. 8, 2009, now Pat. No. Des. 628,018.
- (51) **LOC (9) Cl.** **07-01**
- (52) **U.S. Cl.** **D7/393; D7/608**
- (58) **Field of Classification Search** D7/603-608,
D7/509, 511; D9/531, 537, 549, 552, 555,
D9/559; 215/12.1, 12.2, 13.1; 190/100,
190/115; 150/107, 110; 16/110.1; 220/752,
220/753, 755, 756; D3/273, 274, 276, 291;
D8/107, 300, 315, 306
See application file for complete search history.

OTHER PUBLICATIONS

U.S. Appl. No. 29/305,912, filed Mar. 31, 2008, Gilbert.

(Continued)

Primary Examiner — Terry Wallace
(74) *Attorney, Agent, or Firm* — Davis Wright Tremaine
LLP; George C. Rondeau, Jr.

(57) **CLAIM**
The ornamental design for an handle for an insulated bottle,
as shown and described.

(56) **References Cited**

U.S. PATENT DOCUMENTS

1,044,757 A	11/1913	Decker et al.	
D108,417 S	2/1938	Ambrose	
D179,880 S	3/1957	Bramming	
D182,708 S	5/1958	Bramming	
2,981,562 A	6/1961	Long	
D206,914 S	2/1967	Phillips	
D222,521 S	10/1971	Johnson	
D268,727 S	4/1983	Nestrock	
D274,209 S	6/1984	Kikuchi	
D295,355 S	4/1988	Leung	
4,886,176 A *	12/1989	Steakley	215/13.1
D306,953 S	4/1990	Kase et al.	
D308,477 S	6/1990	van den Ordell	
D309,237 S	7/1990	Kobayashi et al.	

DESCRIPTION

FIG. 1 is a top, rear perspective view of the handle for an insulated bottle.
FIG. 2 is a rear view thereof.
FIG. 3 is a front view thereof.
FIG. 4 is a left side view thereof.
FIG. 5 is a right side view thereof.
FIG. 6 is a top plan view thereof; and,
FIG. 7 is a bottom plan view thereof.
The broken lines are for illustrative purposes only and form no part of the claimed design.

1 Claim, 6 Drawing Sheets

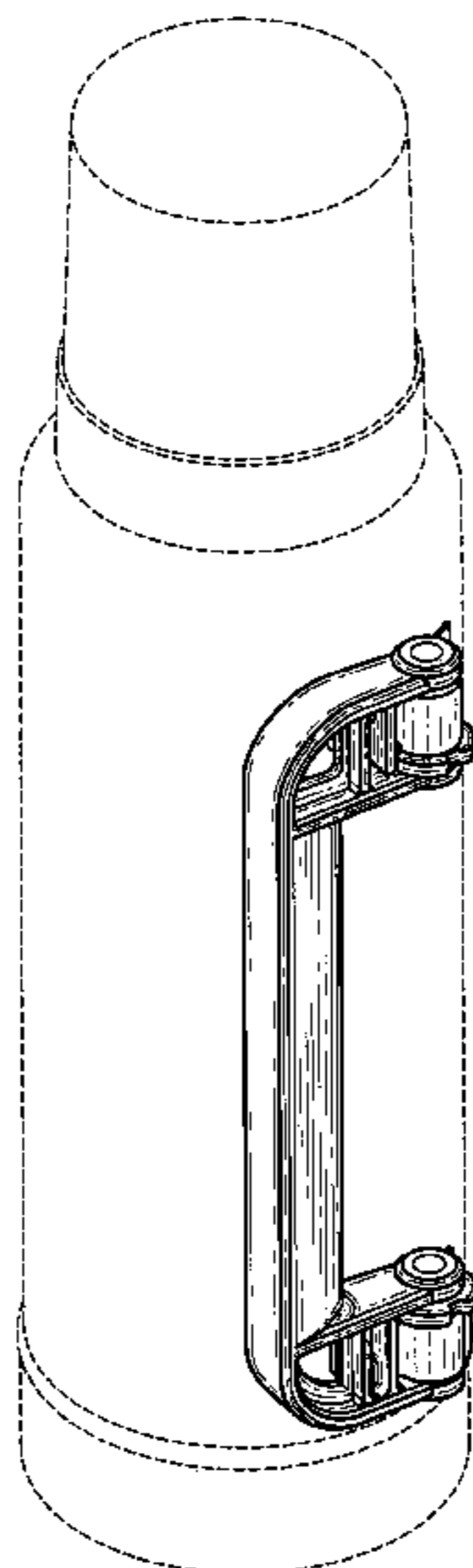

U.S. PATENT DOCUMENTS

D425,374 S	5/2000	Besser et al.	
D425,422 S	5/2000	David	
D428,774 S	8/2000	Moran, Jr.	
D429,118 S	8/2000	Hurlbut	
D429,119 S	8/2000	Hurlbut	
D430,769 S	9/2000	Hurlbut	
D431,969 S	10/2000	Hurlbut	
D432,367 S	10/2000	Segura	
D434,611 S	12/2000	Yu	
D437,528 S	2/2001	Kitamura et al.	
D467,130 S	12/2002	Janky	
D476,859 S *	7/2003	Short	D7/608
D488,675 S	4/2004	Moore	
D528,431 S	9/2006	Brandt et al.	
D530,219 S	10/2006	Brandt et al.	
D533,032 S *	12/2006	Liu et al.	D7/608
D553,914 S *	10/2007	Wahl	D7/608
D572,981 S *	7/2008	Carreno	D7/608
D587,533 S	3/2009	Carreno	
D592,909 S	5/2009	Alviar et al.	

OTHER PUBLICATIONS

U.S. Appl. No. 29/344,046, filed Sep. 22, 2009, Gilbert.
 Aladdin International Corporation® “Thermal Retention Products Price List,” Feb. 1, 1986.
 Aladdin® Stanley® “Half Gallon Unbreakable Steel Vacuum Bottle 1.9 Liters” Brochure.
 Aladdin® “Stanley® Quart Unbreakable Steel Vacuum Bottle 950 mL” Brochure.
 Aladdin® “Stanley® Wide Mouth Unbreakable Steel Vacuum Bottle 24 oz. (710mL)” Brochure.
 Aladdin® “Stanley® Quart with two 12-oz. Stanley Foam-Insulated Travel Mugs, Unbreakable Steel Vacuum Bottle (950mL)” Brochure.

Aladdin® “Rugged American™ Quart Steel Thermos” Brochure.
 Aladdin® “Envoy™ Unbreakable Steel Vacuum Bottle, Pint (470mL)” Brochure.
 Aladdin® “Envoy 950™ Unbreakable Steel Vacuum Bottle, Quart (950mL)” Brochure.
 Aladdin® “Executive™ 0.7 Liter, 0.5 Liter, 1 Liter, The All Steel Bottles . . . That Really Mean Business” Brochure.
 Aladdin® “Glass Vacuum Bottles, Items 6016 and 6032” Brochure.
 Aladdin® “The Omega” Brochure, Aladdin Industries Nashville, TN, 1993.
 Aladdin® “Stanley® Insulated Lunch Cooler 7 Quart Capacity” Brochure.
 Aladdin® “Stanley® Combo” Brochure.
 Aladdin® “Black Stanley® Quart with Two Foam-Insulated 12-oz. Mugs Unbreakable Steel Vacuum Bottle 950 mL” Brochure.
 Aladdin® “The Stanley Fourth Quarter Advertising Campaign” Brochure.
 Aladdin® Stanley® 10 N 10 Rugged American Item #4232, Quart, Half Gallon and 24 Ounce Widemouth Stanley® Item #4032, 4032BL, 4064, 4024, Stanley® Cooler Item #4100, Brochure.
 Aladdin® “Heavy Duty Thermo Bottles 10 N 10, Item #2134 and Item 2123” Brochure.
 Aladdin® “Stanley® Gift Sets Item #4032SBL” Brochure.
 Pacific Market, Inc. “Joe Vacuum Bottle” worksheet, Dec. 1998.
 Contemporary Classics “1996 Centennial Olympic Collection” Brochure.
 Stanley classic Bottle shown on photo. Sold more than one year prior to Mar. 31, 2008.
 Stanley Outdoor Bottle shown on photo. Sold more than one year prior to Mar. 31, 2008.

* cited by examiner

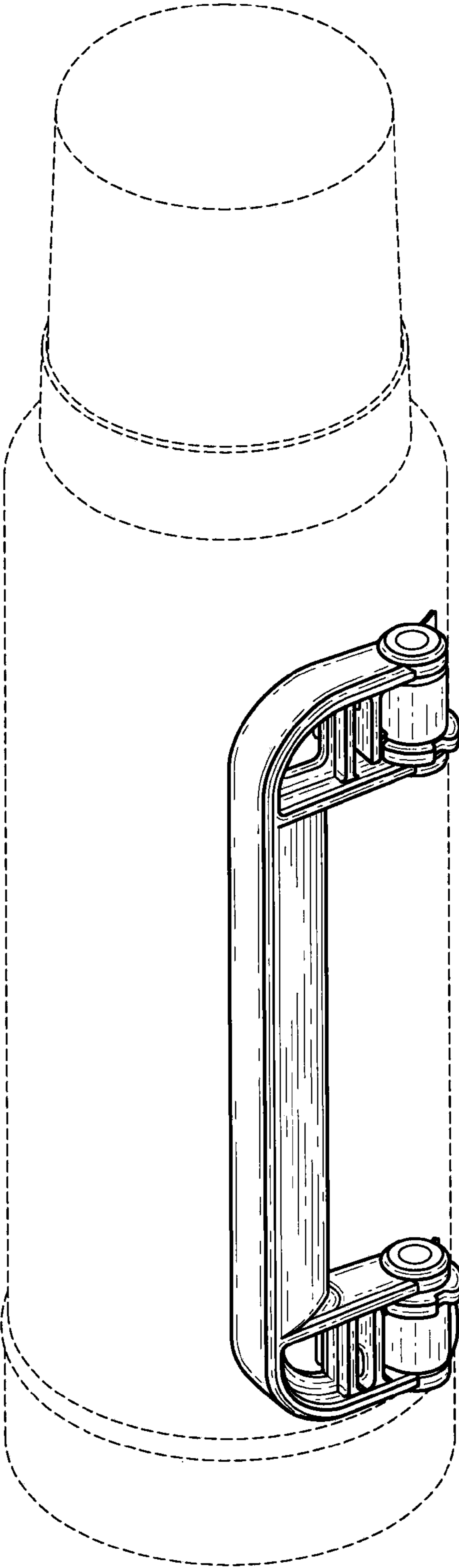

Fig. 1

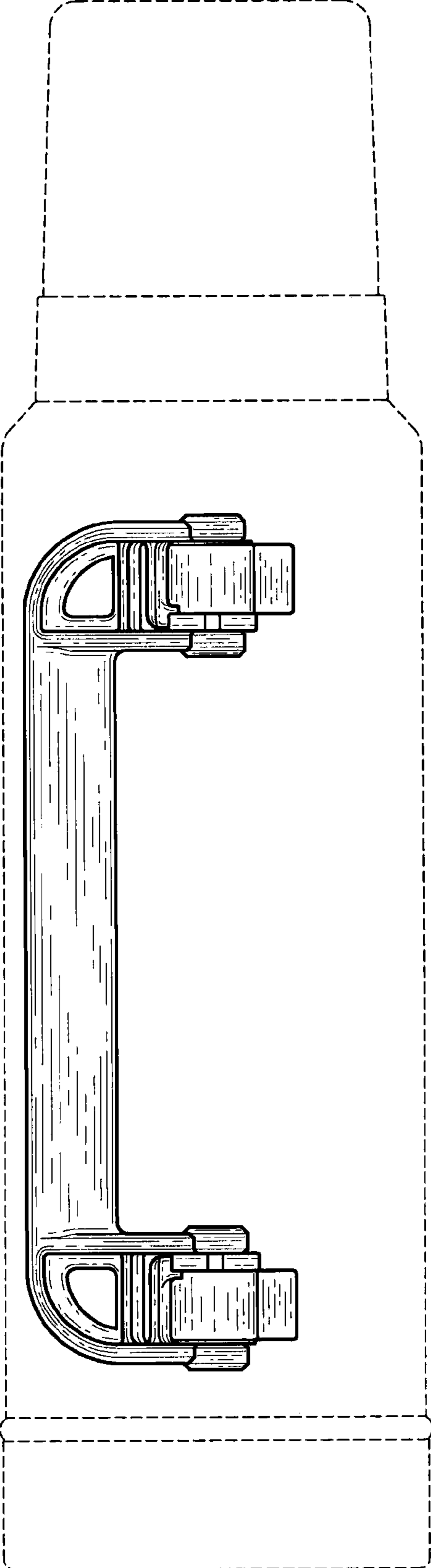

Fig. 2

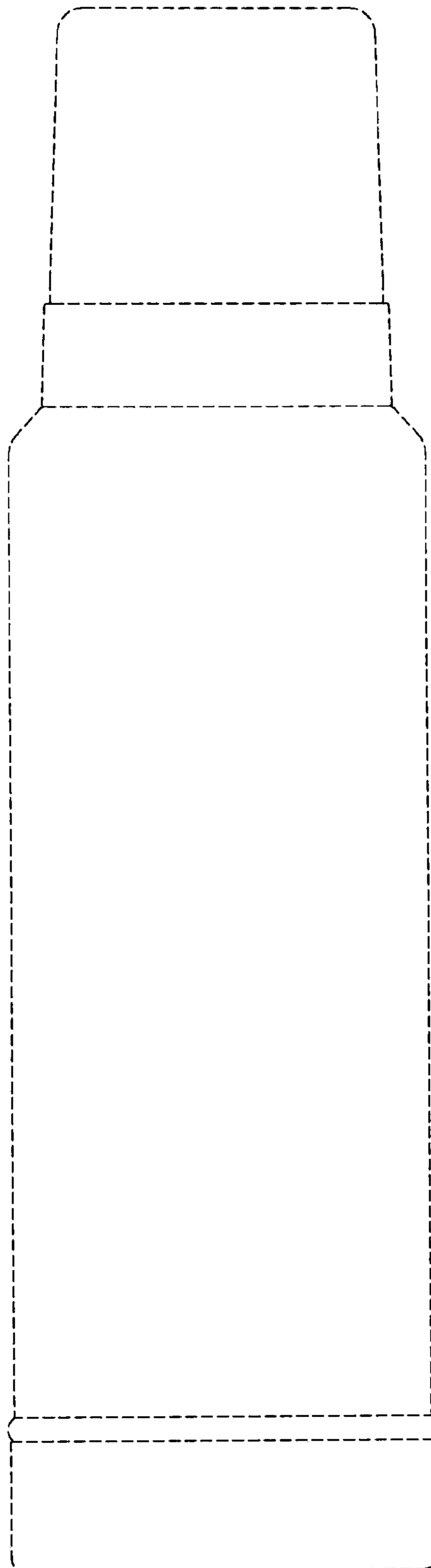

Fig. 3

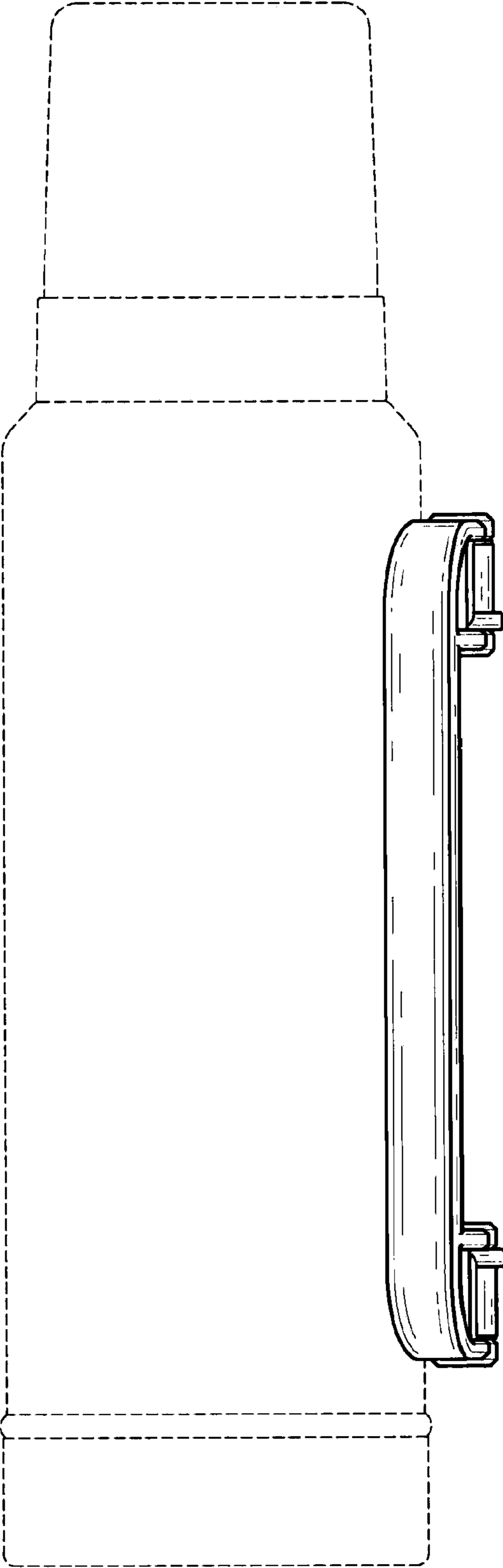

Fig. 4

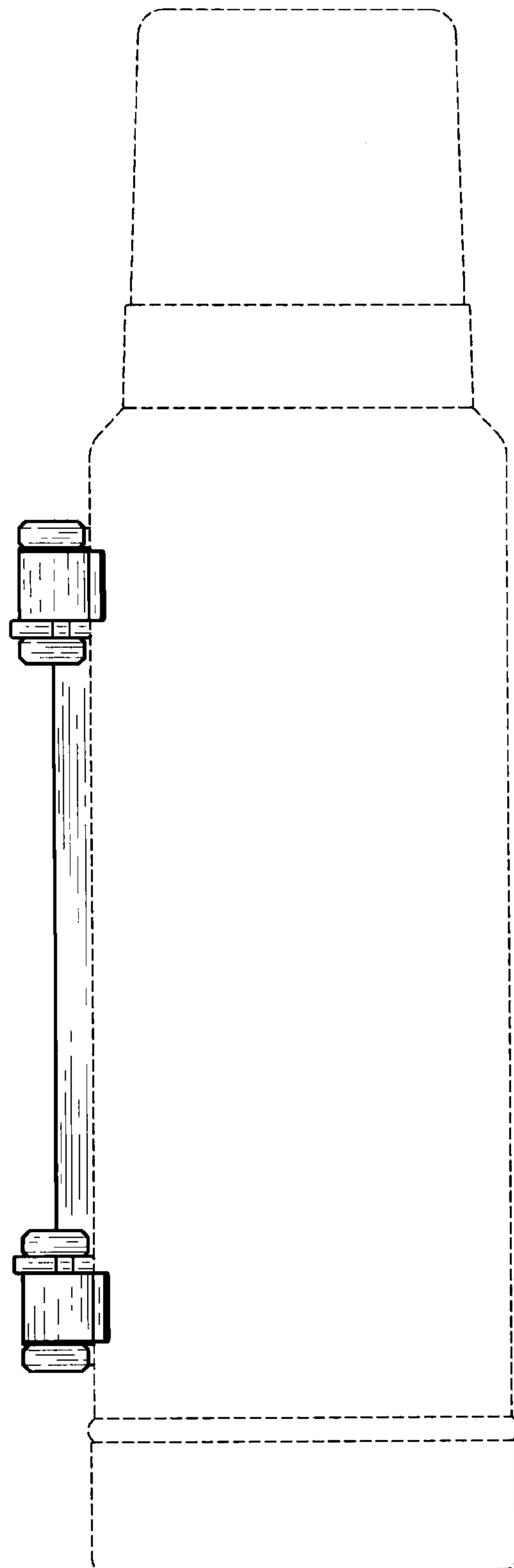

Fig. 5

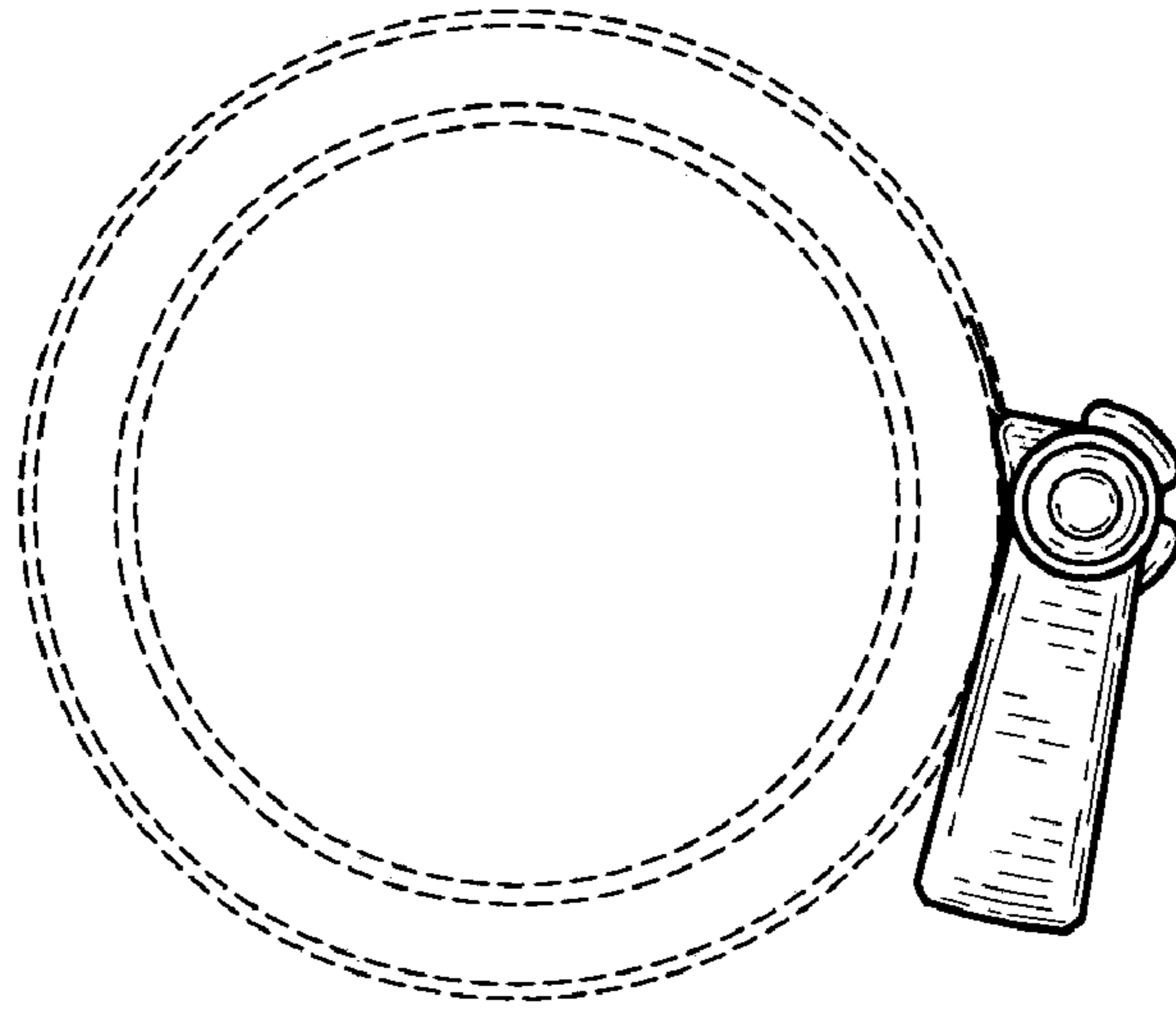

Fig. 6

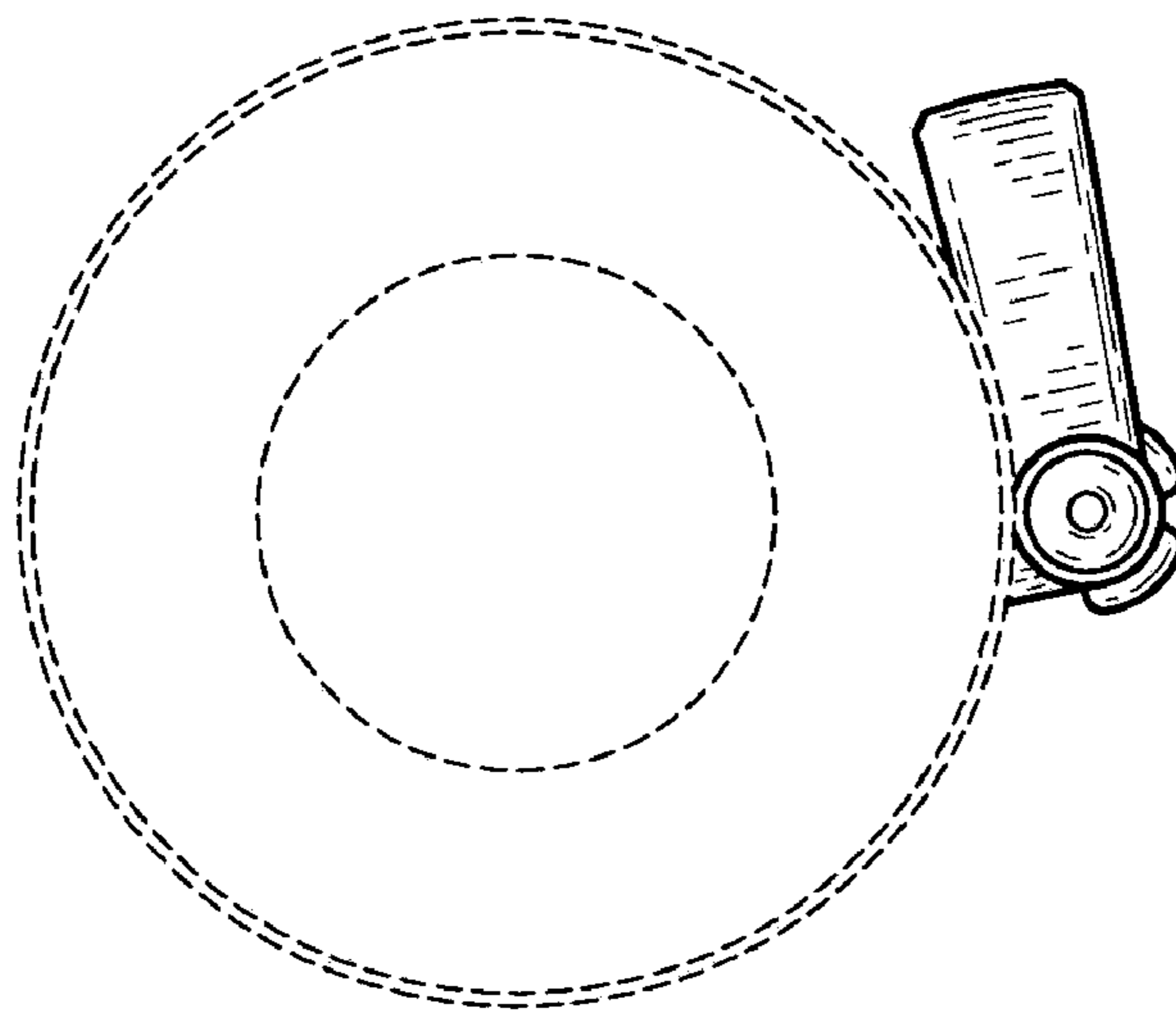

Fig. 7