



US00D642764S

(12) **United States Design Patent**  
**Elden**

(10) **Patent No.:** **US D642,764 S**

(45) **Date of Patent:** **\*\* Aug. 2, 2011**

(54) **LIGHTWEIGHT HIGH LOAD CAPACITY  
FOLDING UTILITY CART WITH  
ERGONOMIC HANDLE**

(76) Inventor: **Richard Elden**, Carson, CA (US)

(\*\*) Term: **14 Years**

(21) Appl. No.: **29/372,670**

(22) Filed: **Dec. 22, 2010**

(51) **LOC (9) Cl.** ..... **12-02**

(52) **U.S. Cl.** ..... **D34/24**

(58) **Field of Classification Search** ..... D34/12-27;  
280/652, 639, 47.131, 47.26, DIG. 3  
See application file for complete search history.

D525,758	S *	7/2006	Lynch	.....	D34/12
7,731,221	B2	6/2010	Bess		
D633,680	S *	3/2011	Gimeno et al.	.....	D34/24
2002/0050429	A1	5/2002	Nykoluk et al.		
2002/0139628	A1	10/2002	Chang		
2002/0144874	A1	10/2002	Nykoluk et al.		
2004/0211635	A1	10/2004	Lu		
2009/0212536	A1	8/2009	Tadeo		

\* cited by examiner

*Primary Examiner* — Cynthia Ramirez

(74) *Attorney, Agent, or Firm* — Thomas I. Rozsa

(57) **CLAIM**

The ornamental design for a lightweight high load capacity folding utility cart with ergonomic handle, as shown and described.

(56) **References Cited**

**U.S. PATENT DOCUMENTS**

D134,941	S *	2/1943	Hensen	.....	D34/24
2,564,939	A	8/1951	Weast		
2,786,692	A	3/1957	Timpson		
2,920,900	A *	1/1960	Best	.....	280/652
3,092,395	A	6/1963	Mitty et al.		
3,135,527	A	6/1964	Knapp		
3,191,956	A *	6/1965	Rizzuto	.....	280/641
3,207,526	A *	9/1965	Brodeck	.....	280/652
D292,135	S	9/1987	Grube		
4,765,644	A	8/1988	Bell		
4,765,646	A	8/1988	Cheng		
5,197,754	A	3/1993	Ward		
D334,640	S *	4/1993	Forish	.....	D34/24
5,244,219	A	9/1993	Hadlum		
D383,581	S *	9/1997	Ordonez	.....	D34/5
5,988,671	A	11/1999	Abelbeck et al.		
6,598,898	B2	7/2003	Chu		
D477,916	S	8/2003	Nykoluk		
6,651,791	B1	11/2003	Nykoluk et al.		
6,918,474	B2	7/2005	Nykoluk		

**DESCRIPTION**

FIG. 1 is a perspective view of the lightweight high load capacity folding utility cart with ergonomic handle, showing my design;  
 FIG. 2 is a front elevational view thereof;  
 FIG. 3 is a rear elevational view thereof;  
 FIG. 4 is a side elevational view when viewed from the right side thereof;  
 FIG. 5 is a side elevational view when viewed from the left side thereof;  
 FIG. 6 is a top view thereof;  
 FIG. 7 is a bottom view thereof; and,  
 FIG. 8 is a bottom perspective view thereof.  
 The cross-hatching shading in the figures is fragmentarily shown for convenience of illustration, it being understood that the shading is uniformly continued over the surfaces on which it appears.

**1 Claim, 7 Drawing Sheets**

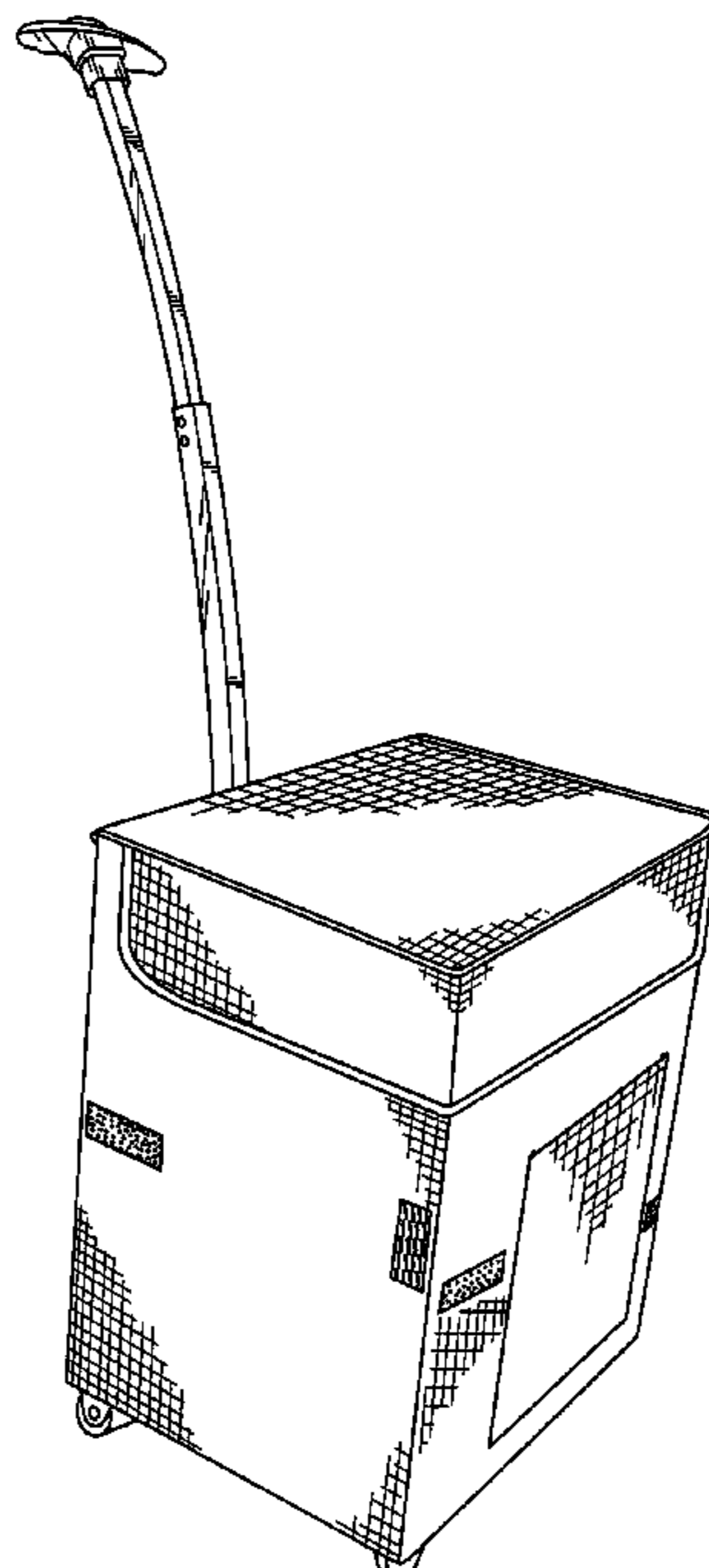

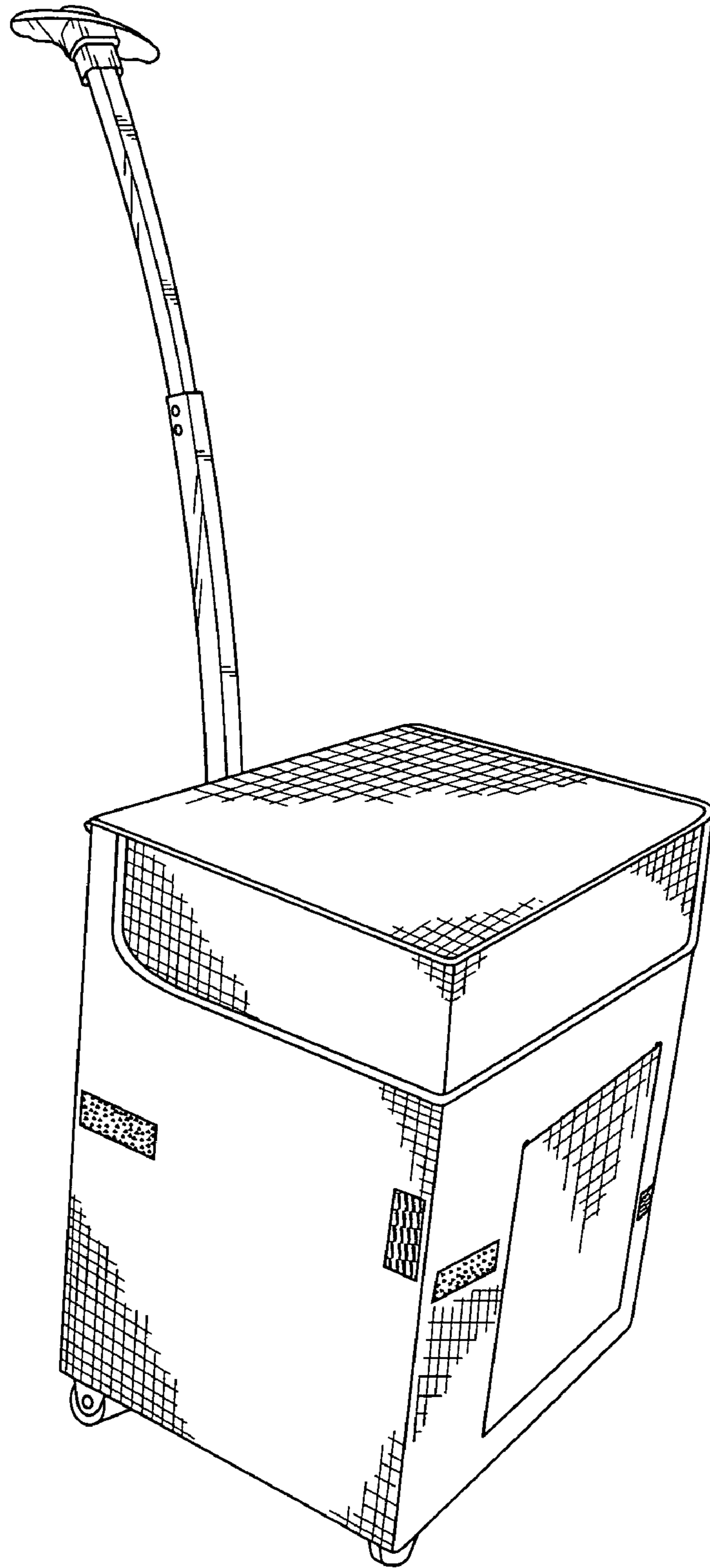

FIG. 1

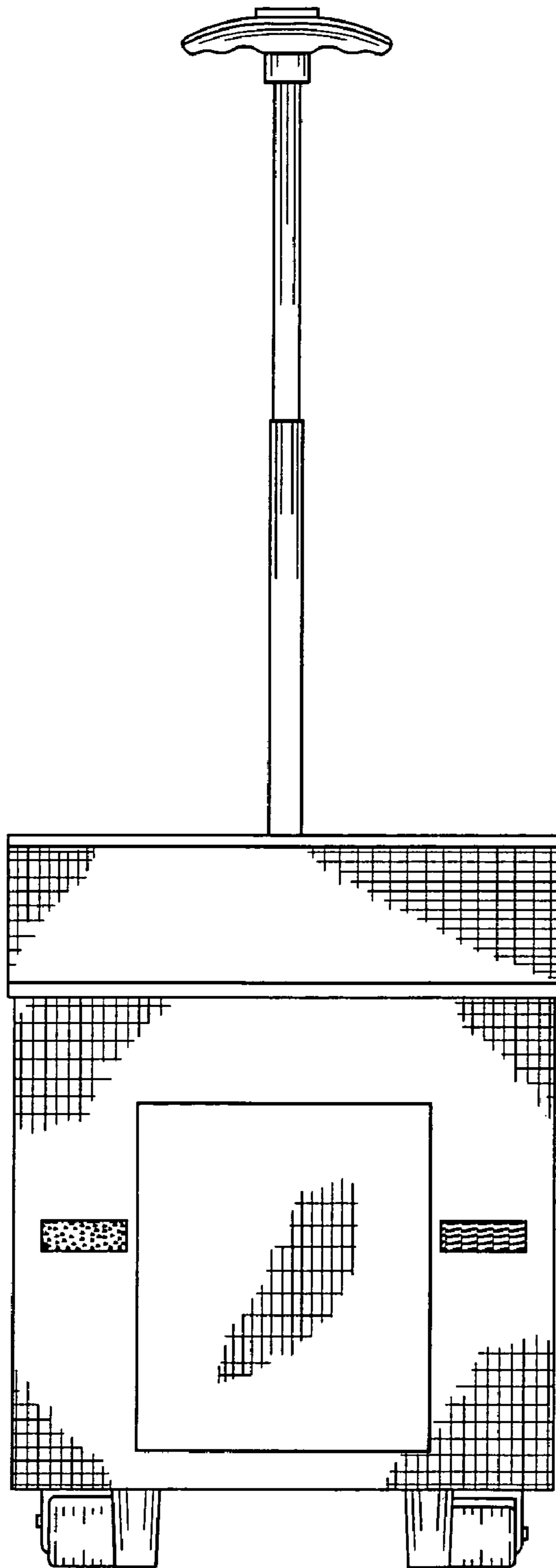

FIG. 2

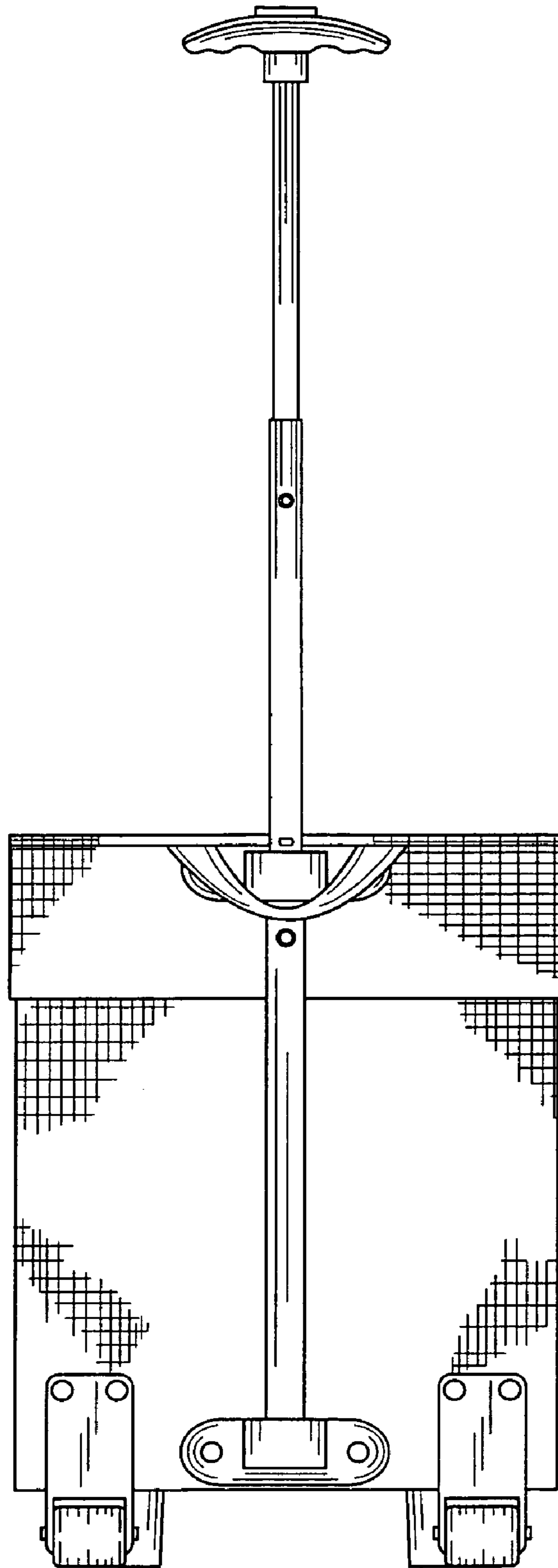

FIG. 3

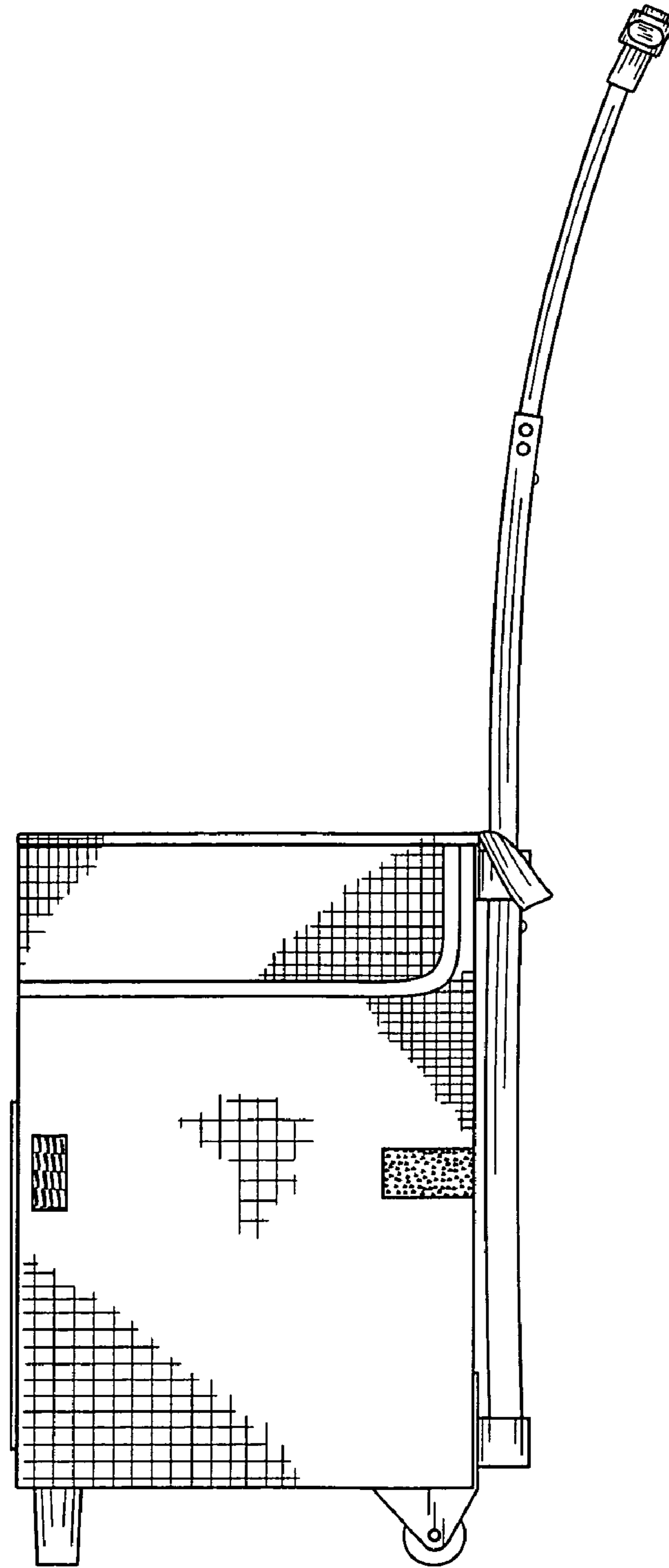

FIG. 4

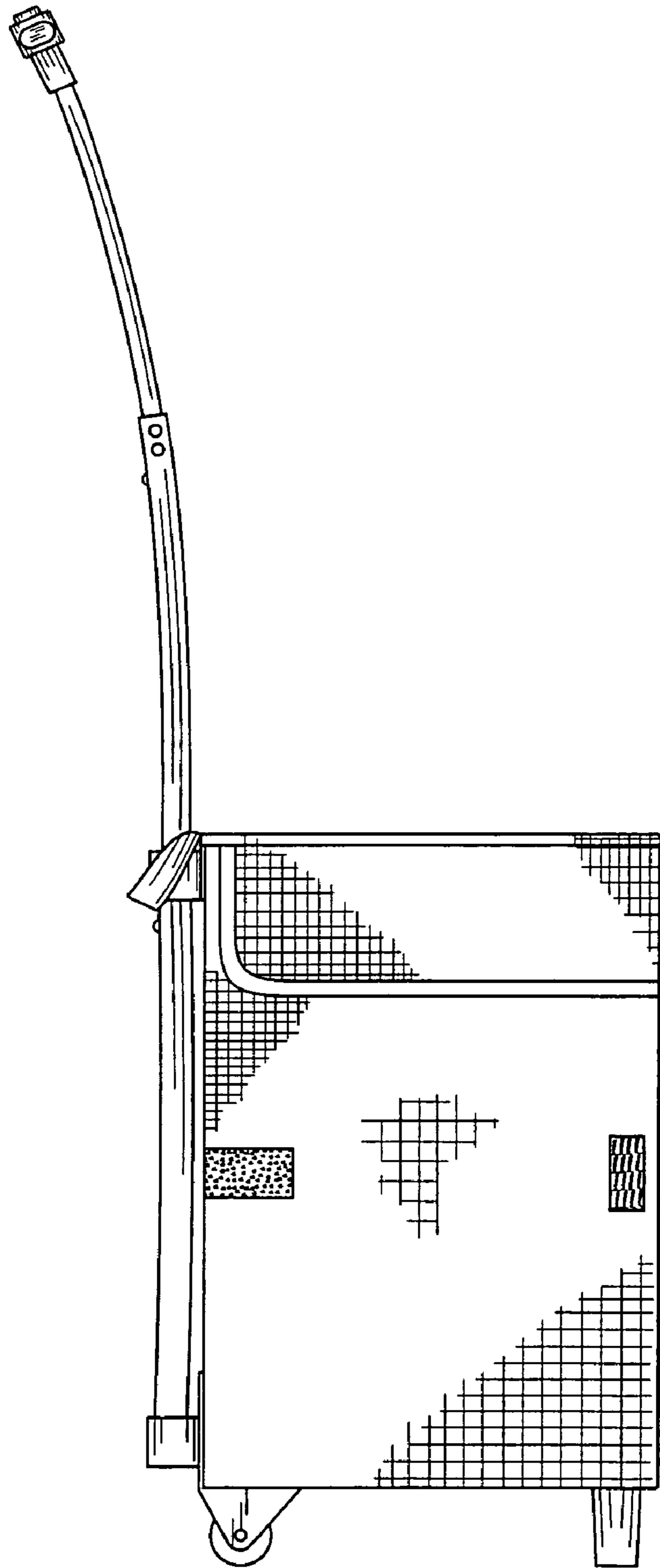

FIG. 5

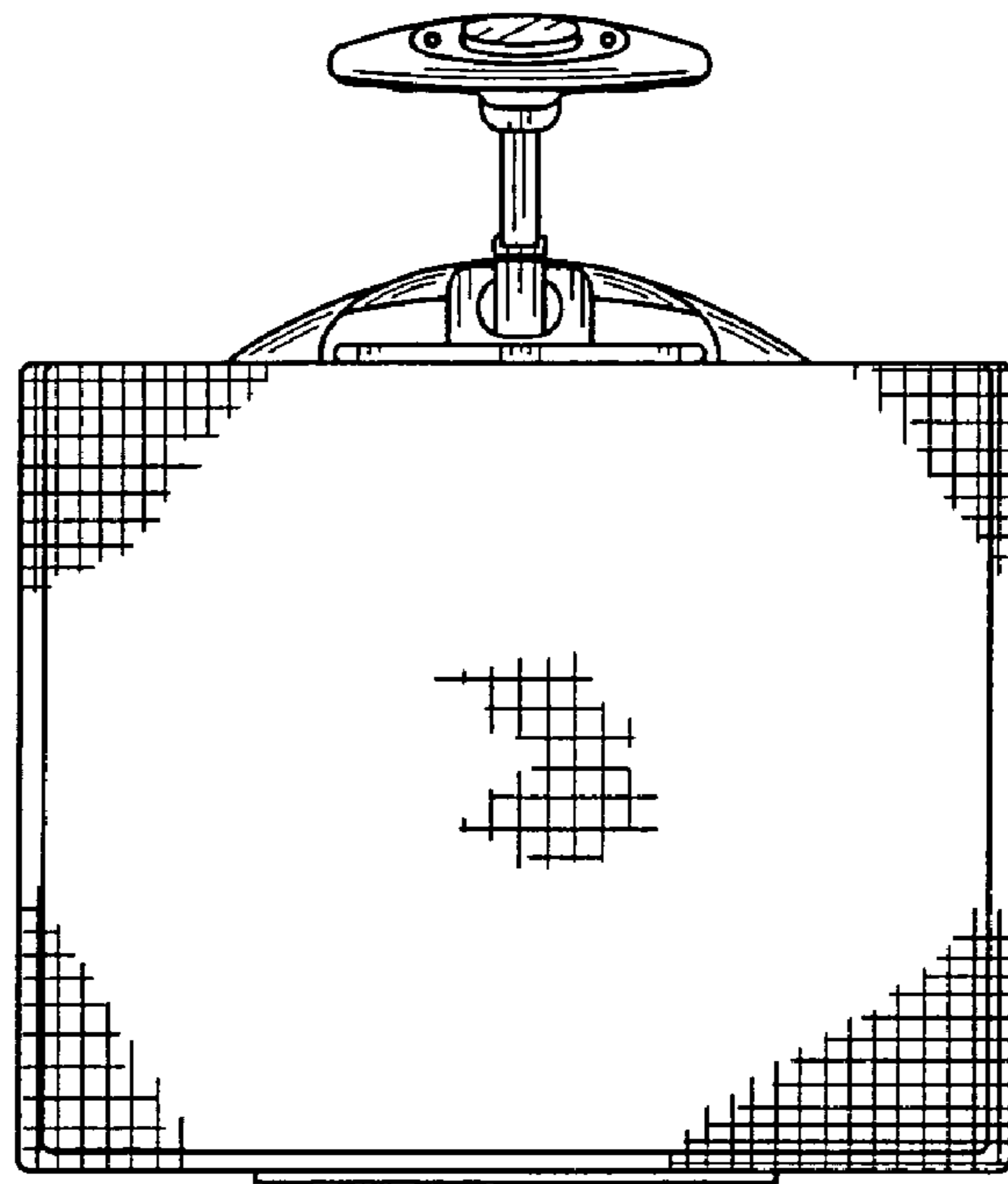

FIG. 6

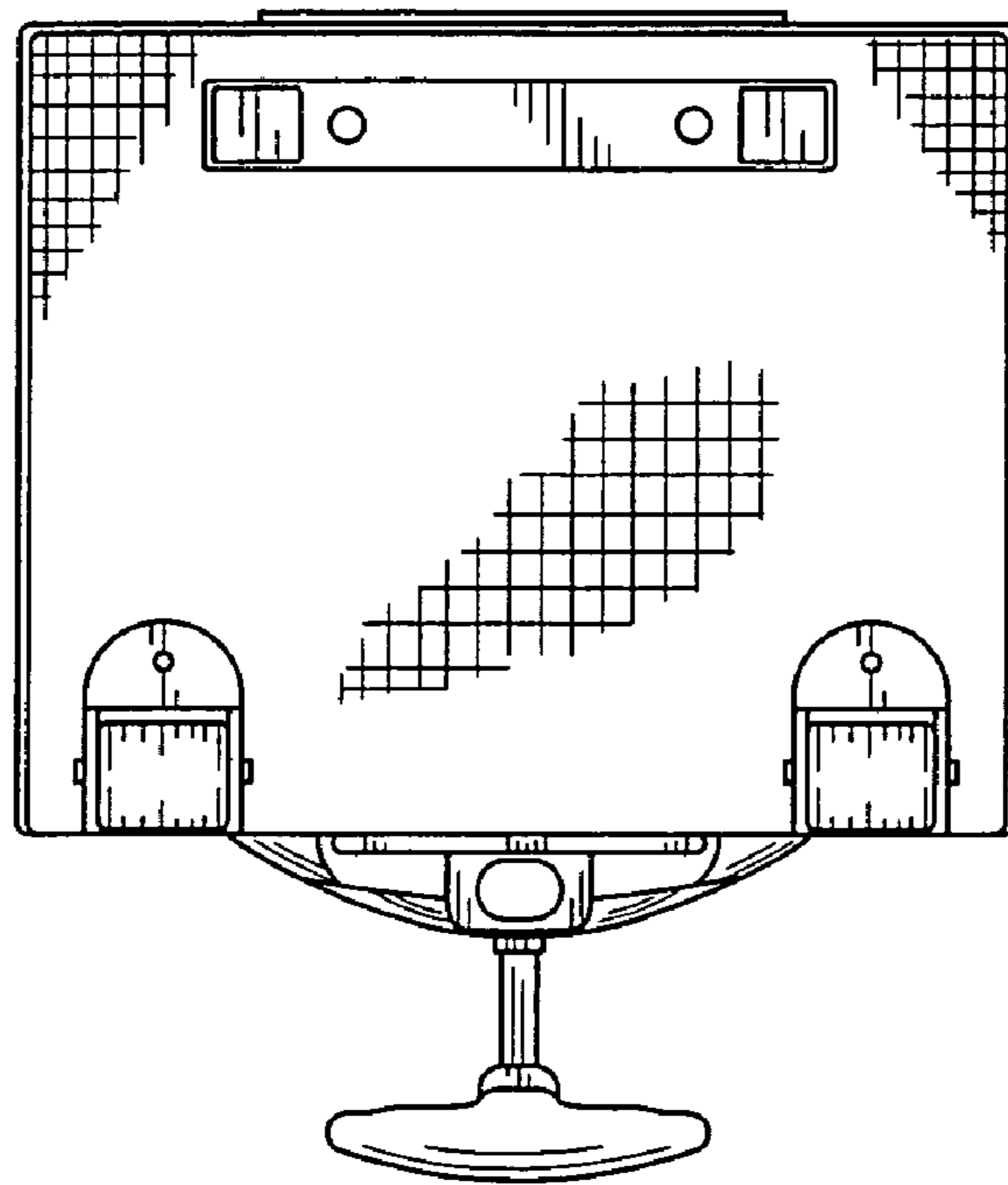

FIG. 7

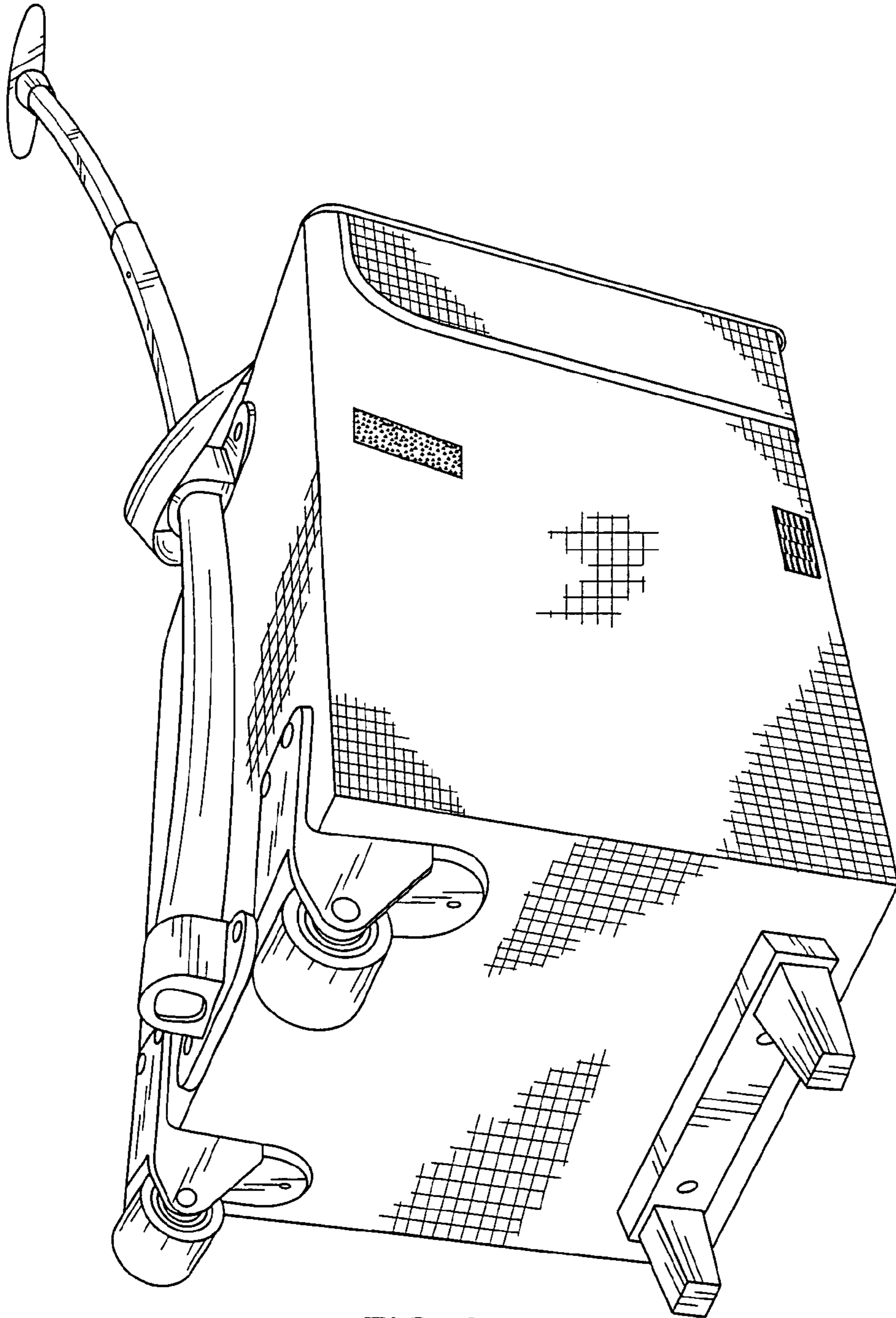

FIG. 8