



US00D642724S

(12) **United States Design Patent**
Galipeau et al.

(10) **Patent No.:** **US D642,724 S**

(45) **Date of Patent:** **** Aug. 2, 2011**

(54) **LUMINAIRE FOR ROAD LIGHTING**

(56) **References Cited**

(75) Inventors: **Guy Galipeau**, Ste-Therese (CA);
Michel Fortin, Ste-Marthe-sur-le-la
(CA); **Mathieux Bergeron**, St-Eustache
(CA); **Jean-Francois Duquette**,
Kirkland (CA); **Jonathan Hardy**, Laval
(CA); **Johnathan Cote**, Boucherville
(CA)

(73) Assignee: **Koninklijke Philips Electronics N.V.**,
Eindhoven (NL)

(**) Term: **14 Years**

(21) Appl. No.: **29/383,377**

(22) Filed: **Jan. 17, 2011**

Related U.S. Application Data

(63) Continuation of application No. 29/357,770, filed on
Mar. 17, 2010, now Pat. No. Des. 631,181.

(51) **LOC (9) Cl.** **26-05**

(52) **U.S. Cl.** **D26/71**

(58) **Field of Classification Search** D26/67-71,
D26/85, 92; 362/145, 183, 231, 240, 249.02,
362/249.03, 249.04, 249.06, 249.16, 373,
362/431

See application file for complete search history.

U.S. PATENT DOCUMENTS

D199,327	S	*	10/1964	Guth, Jr.	D26/72
7,420,811	B2	*	9/2008	Chan	361/709
D599,939	S	*	9/2009	Zheng et al.	D26/71
D600,846	S	*	9/2009	Hsu et al.	D26/71
D607,593	S	*	1/2010	Yoo	D26/71
D608,927	S	*	1/2010	Hsu et al.	D26/71
7,682,055	B2	*	3/2010	Shuai et al.	362/373
D615,690	S	*	5/2010	Zheng et al.	D26/71
D622,888	S	*	8/2010	Chakravarty et al.	D26/71
D622,889	S	*	8/2010	Zheng	D26/71
2009/0103300	A1	*	4/2009	Chang	362/249.02
2010/0195326	A1	*	8/2010	Boxler et al.	362/235

* cited by examiner

Primary Examiner — Clare E Heflin

(57) **CLAIM**

The ornamental design for a luminaire for road lighting, as shown and described.

DESCRIPTION

FIG. 1 is a top perspective view showing the new design;
FIG. 2 is a bottom perspective view thereof;
FIG. 3 is a front elevational view thereof, the rear elevational
view being a mirror image of that shown;
FIG. 4 is a right side elevational view thereof;
FIG. 5 is a left side elevational view thereof;
FIG. 6 is a top plan view thereof; and,
FIG. 7 is a bottom plan bottom plan view thereof.
The broken lines shown on the drawings depict portions of the
luminaire for road lighting that form no part of the claimed
design.

1 Claim, 7 Drawing Sheets

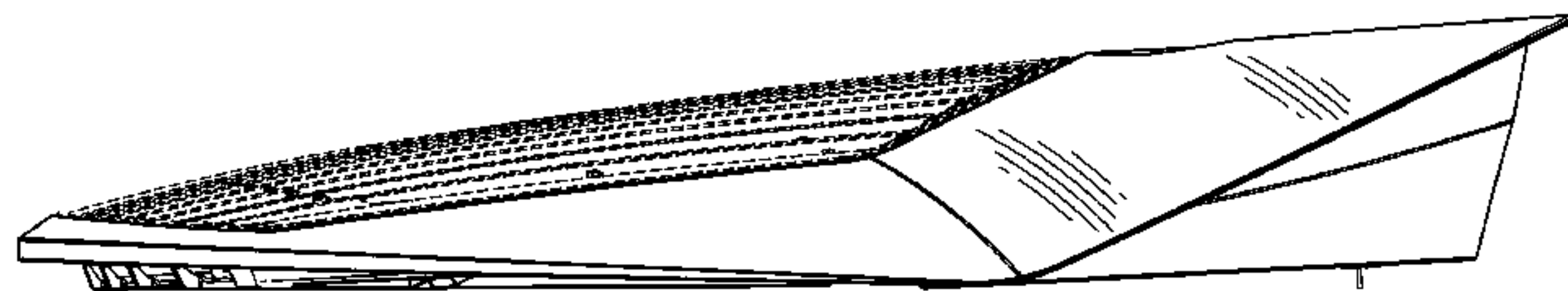
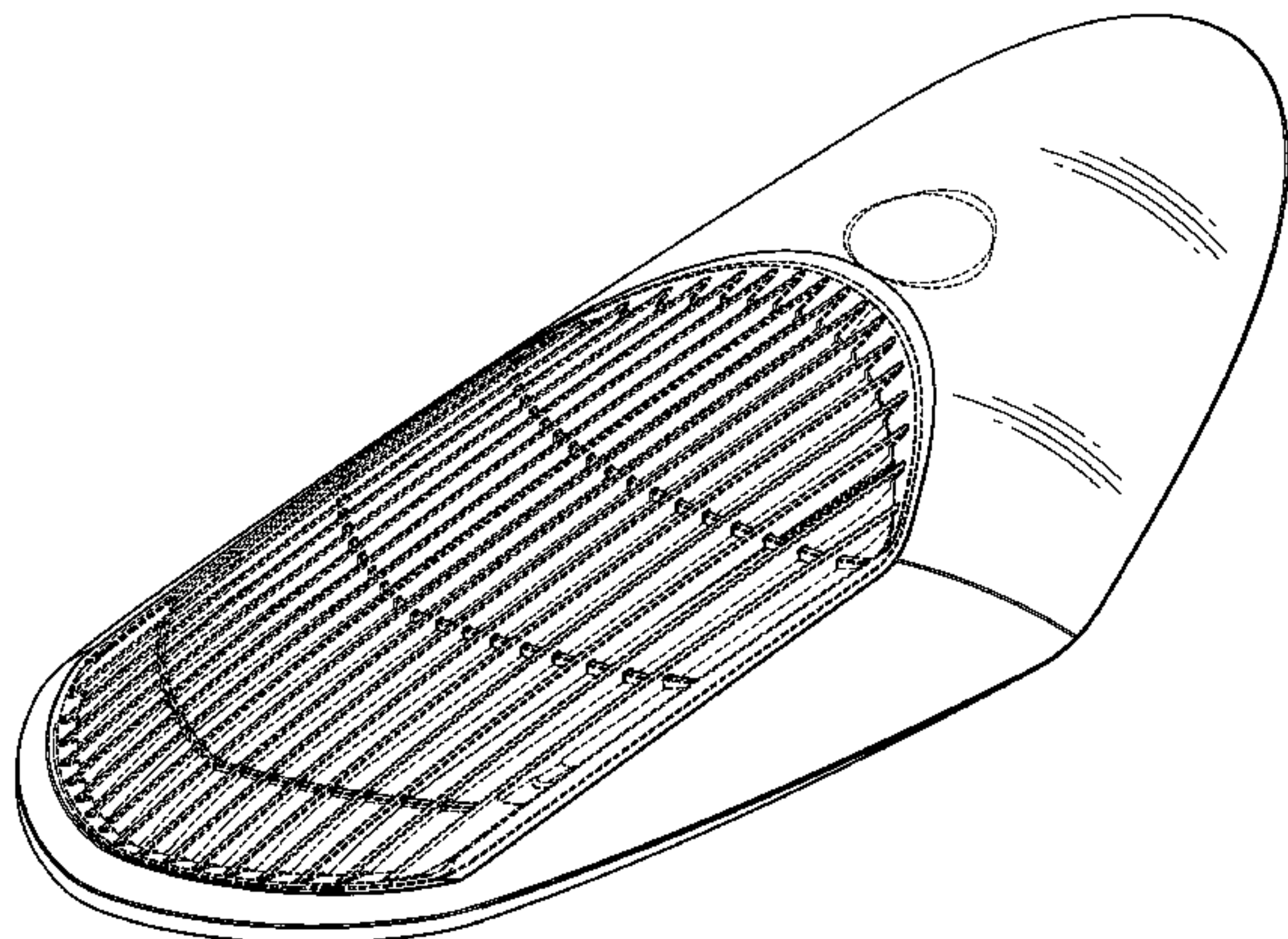

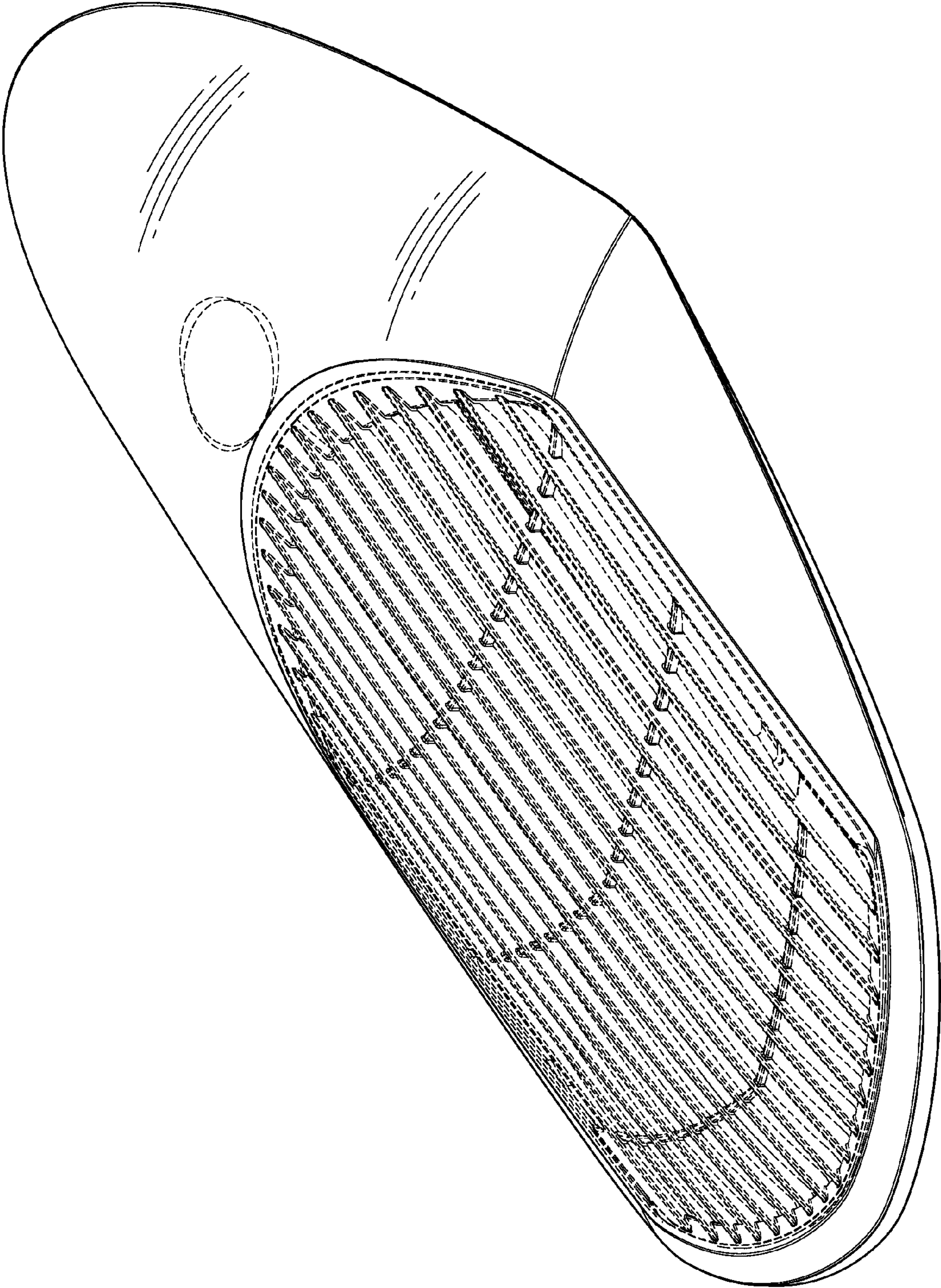

FIG. 1

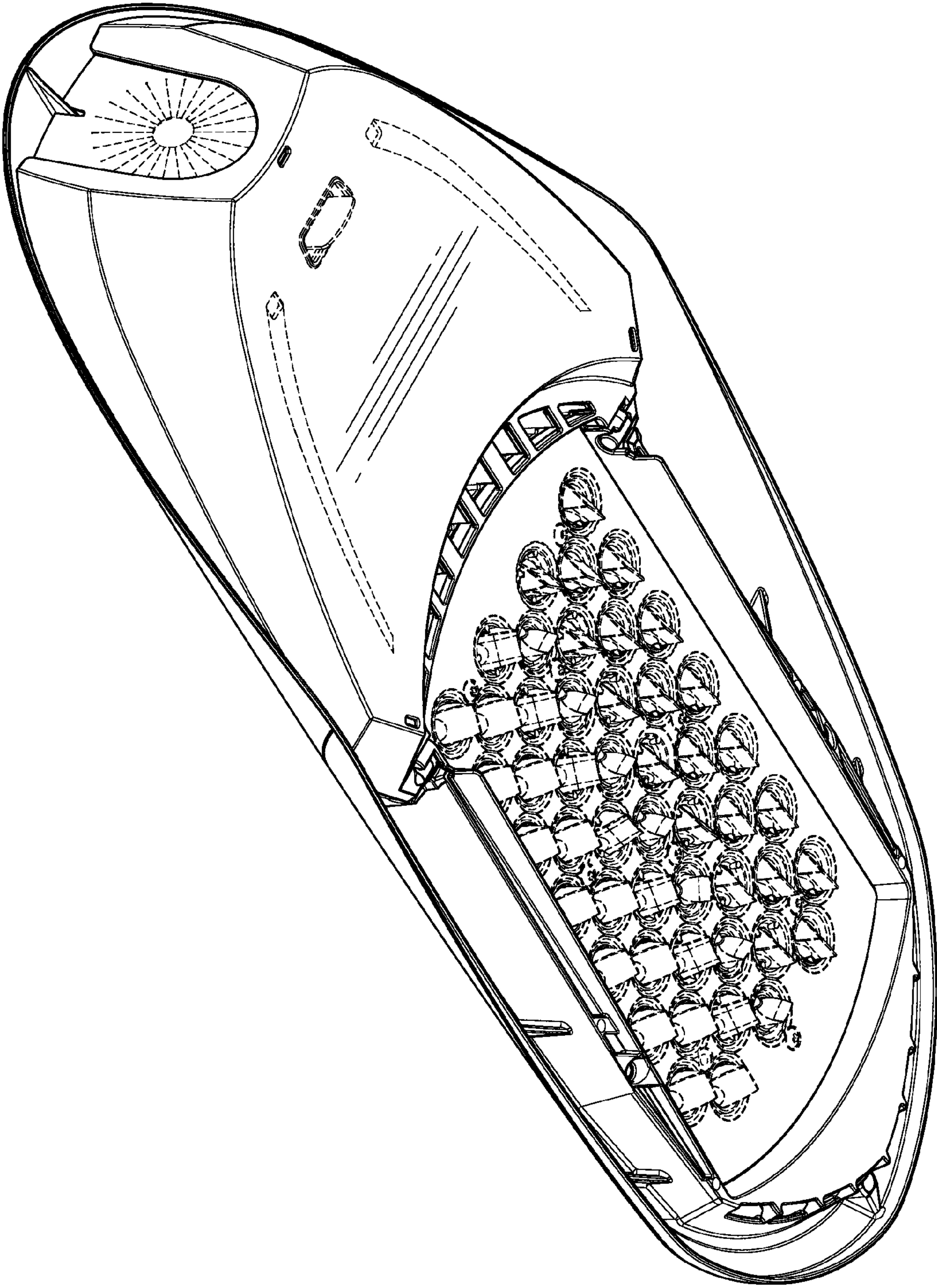

FIG. 2

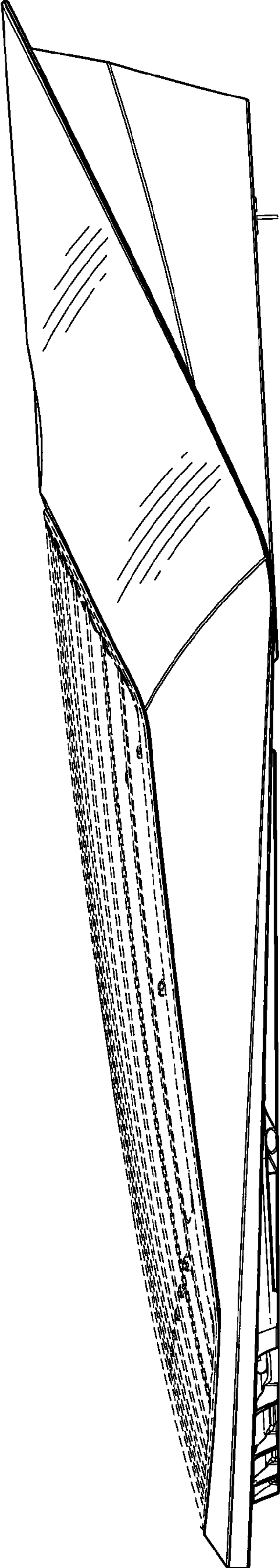

FIG. 3

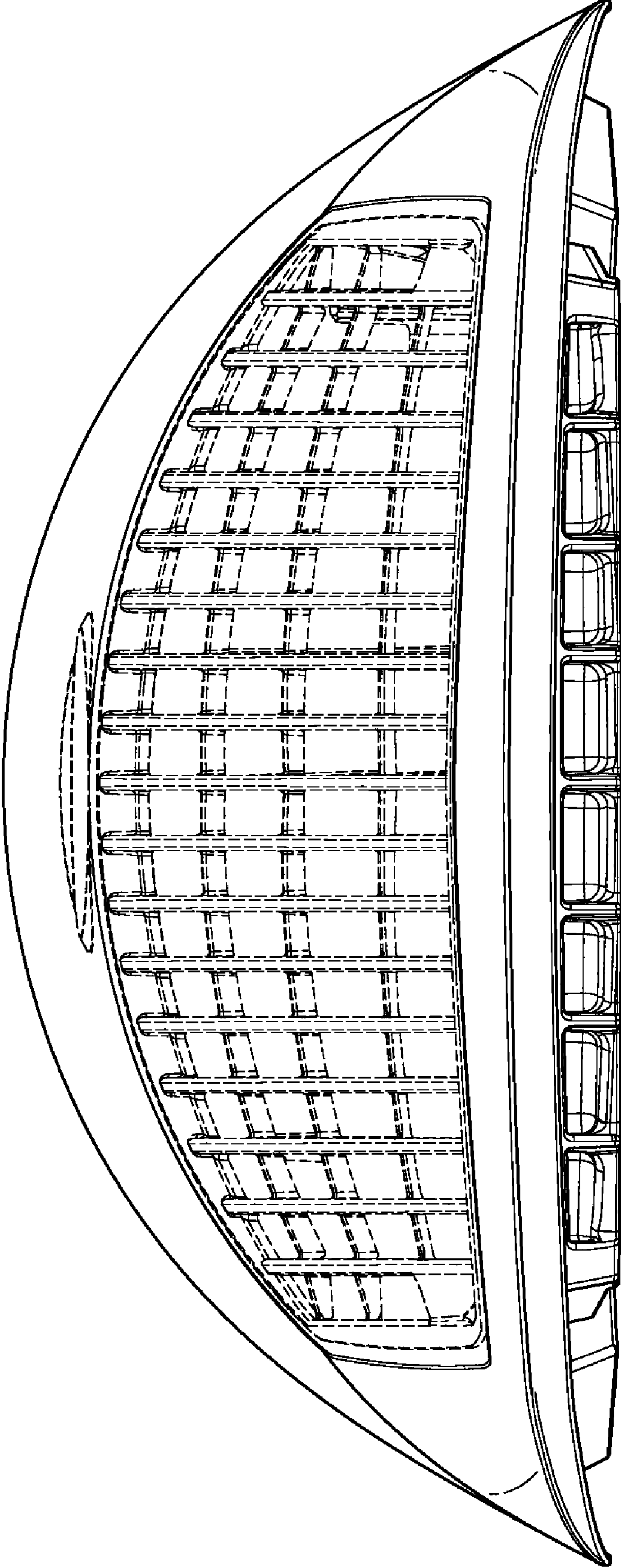

FIG. 4

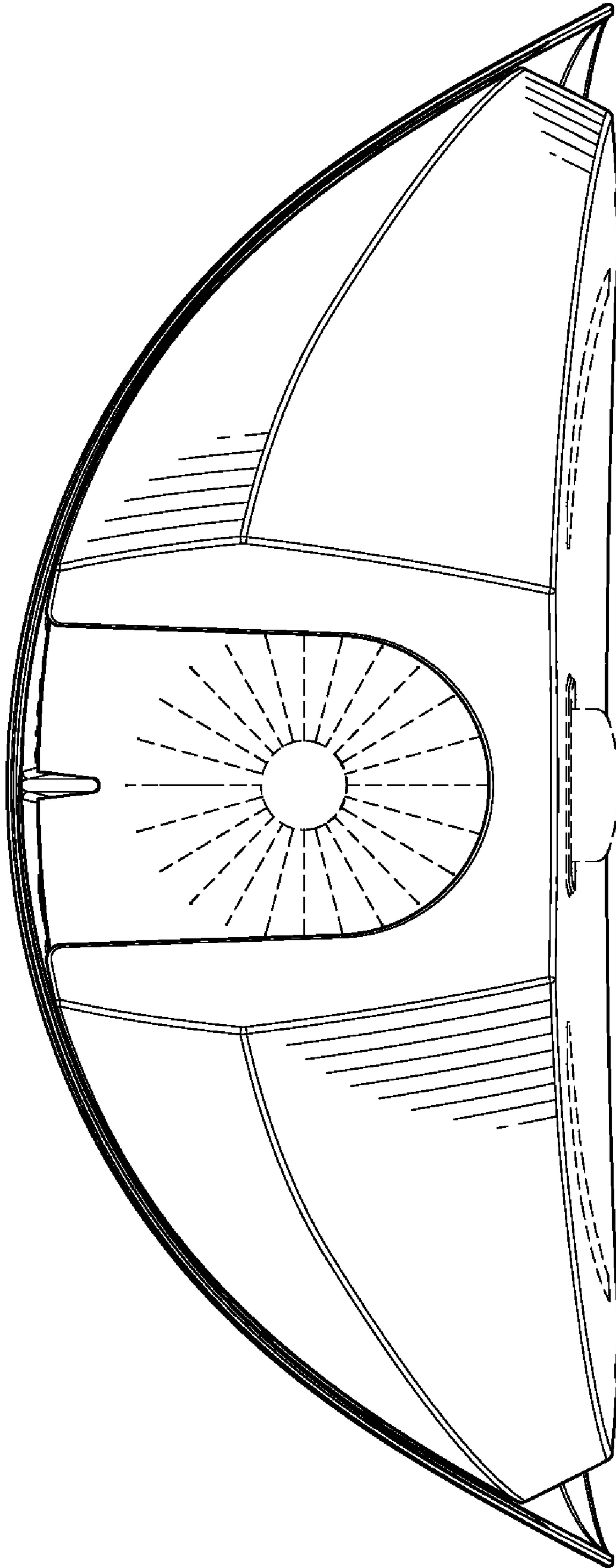

FIG. 5

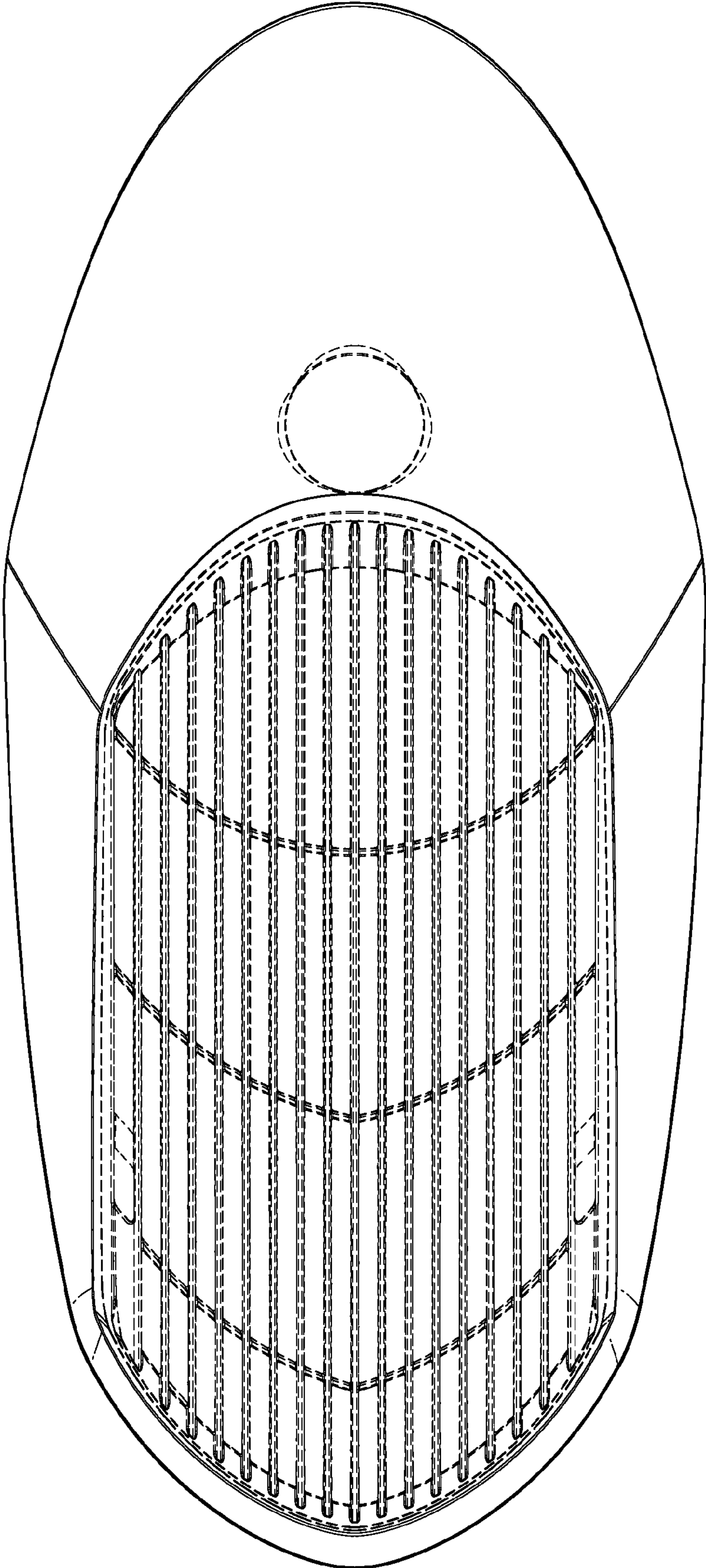

FIG. 6

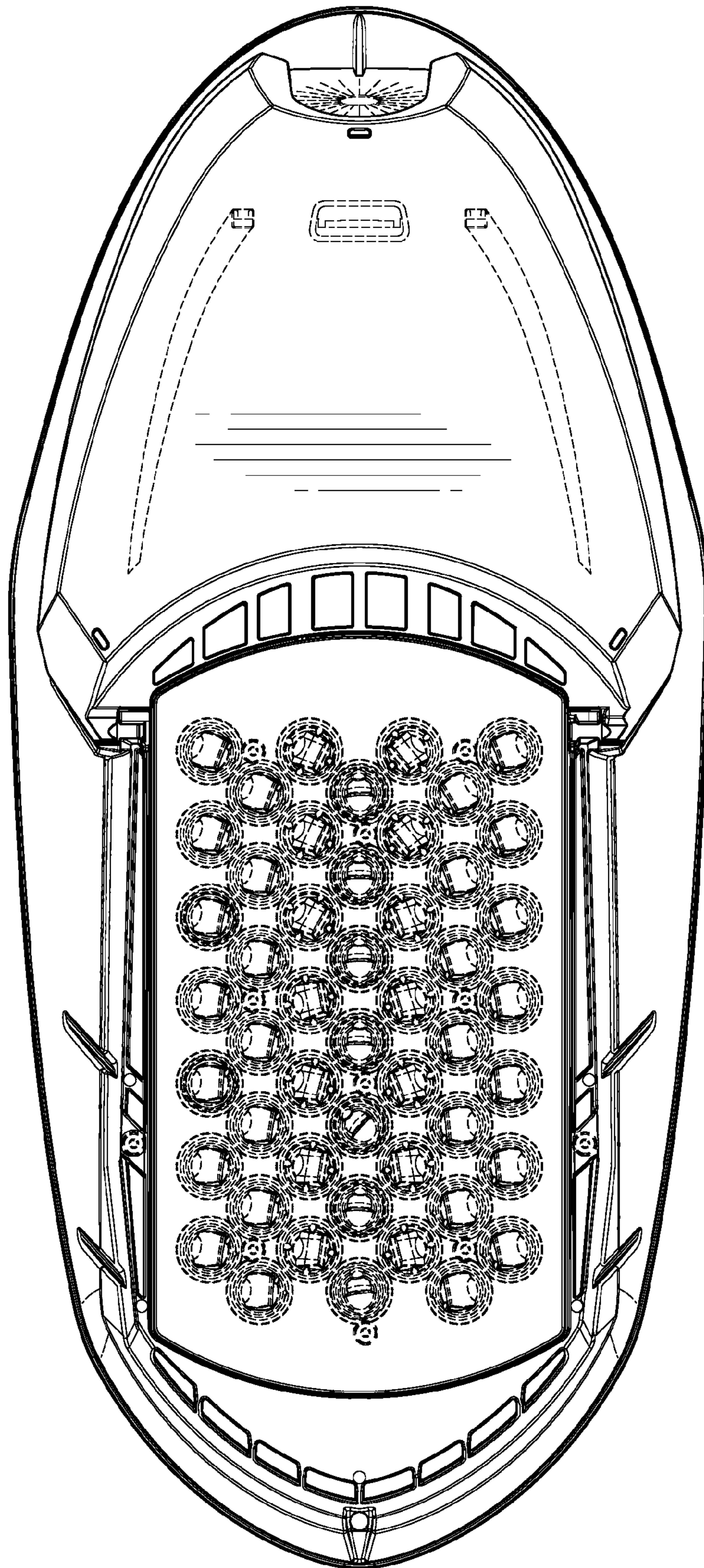

FIG. 7