



US00D642711S

(12) **United States Design Patent**  
**Schneider**

(10) **Patent No.:** **US D642,711 S**

(45) **Date of Patent:** **\*\* Aug. 2, 2011**

(54) **TAILLIGHT FOR A VEHICLE**

*Primary Examiner* — Marcus A Jackson

(75) Inventor: **Alexander Schneider**, Munich (DE)

(74) *Attorney, Agent, or Firm* — Crowell & Moring LLP

(73) Assignee: **Bayerische Motoren Werke Aktiengesellschaft**, Munich (DE)

(57) **CLAIM**

The ornamental design for a taillight for a vehicle, as shown and described.

(\*\*) Term: **14 Years**

(21) Appl. No.: **29/347,798**

**DESCRIPTION**

(22) Filed: **Jun. 7, 2010**

(51) **LOC (9) Cl.** ..... **26-06**

(52) **U.S. Cl.** ..... **D26/28**

(58) **Field of Classification Search** ..... D26/28–36;  
362/459–468, 475–478, 485–487

See application file for complete search history.

This application contains subject matter related to the following co-pending U.S. design patent application:

Application Ser. No. 29/347,801, filed herewith and entitled “Vehicle, Toy, and/or Replicas Thereof”.

FIG. 1 is a left perspective view of a first embodiment of a taillight for a vehicle according to my design;

FIG. 2 is a right perspective view thereof;

FIG. 3 is a front view thereof;

FIG. 4 is a left side view thereof;

FIG. 5 is a right side view thereof;

FIG. 6 is a top view thereof; and

FIG. 7 is a bottom view thereof.

FIG. 8 is a right perspective view of a second embodiment of the taillight for a vehicle, according to my design, with the Taillight for a Vehicle for the opposite side of the vehicle being depicted in the first embodiment;

FIG. 9 is a left perspective view thereof;

FIG. 10 is a front view thereof;

FIG. 11 is a right side view thereof;

FIG. 12 is a left side view thereof;

FIG. 13 is a top view thereof; and,

FIG. 14 is a bottom view thereof.

The broken lines are for illustrative purposes only and form no part of the claimed design.

(56) **References Cited**

U.S. PATENT DOCUMENTS

D409,262 S	5/1999	Stephenson	
D540,714 S	4/2007	Mueller-Stolz	
D549,363 S *	8/2007	Pfeiffer	D26/28
D552,769 S *	10/2007	Leclercq	D26/28
D553,268 S *	10/2007	Pfeiffer	D26/28
D560,292 S *	1/2008	Sato	D26/28
D561,357 S *	2/2008	Leclercq	D26/28
D570,015 S *	5/2008	Hsu	D26/28
D605,793 S *	12/2009	Weil	D26/28

FOREIGN PATENT DOCUMENTS

EM 000482419-0001 10/2006

OTHER PUBLICATIONS

Mini Cooper S, BMW Group PressClub: [www.press.bmwgroup.com](http://www.press.bmwgroup.com), P0029225, Oct. 2006.

\* cited by examiner

**1 Claim, 6 Drawing Sheets**

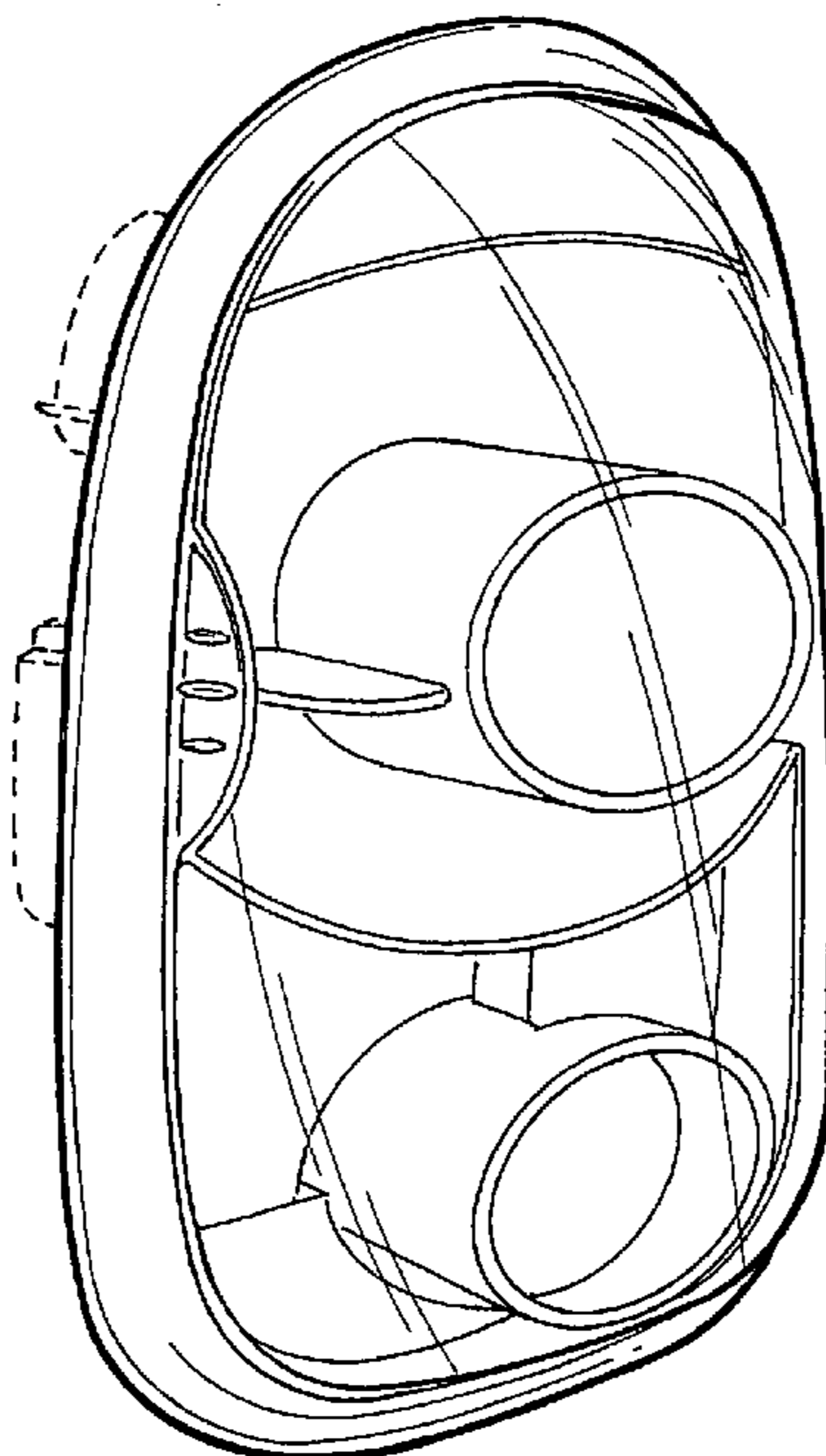

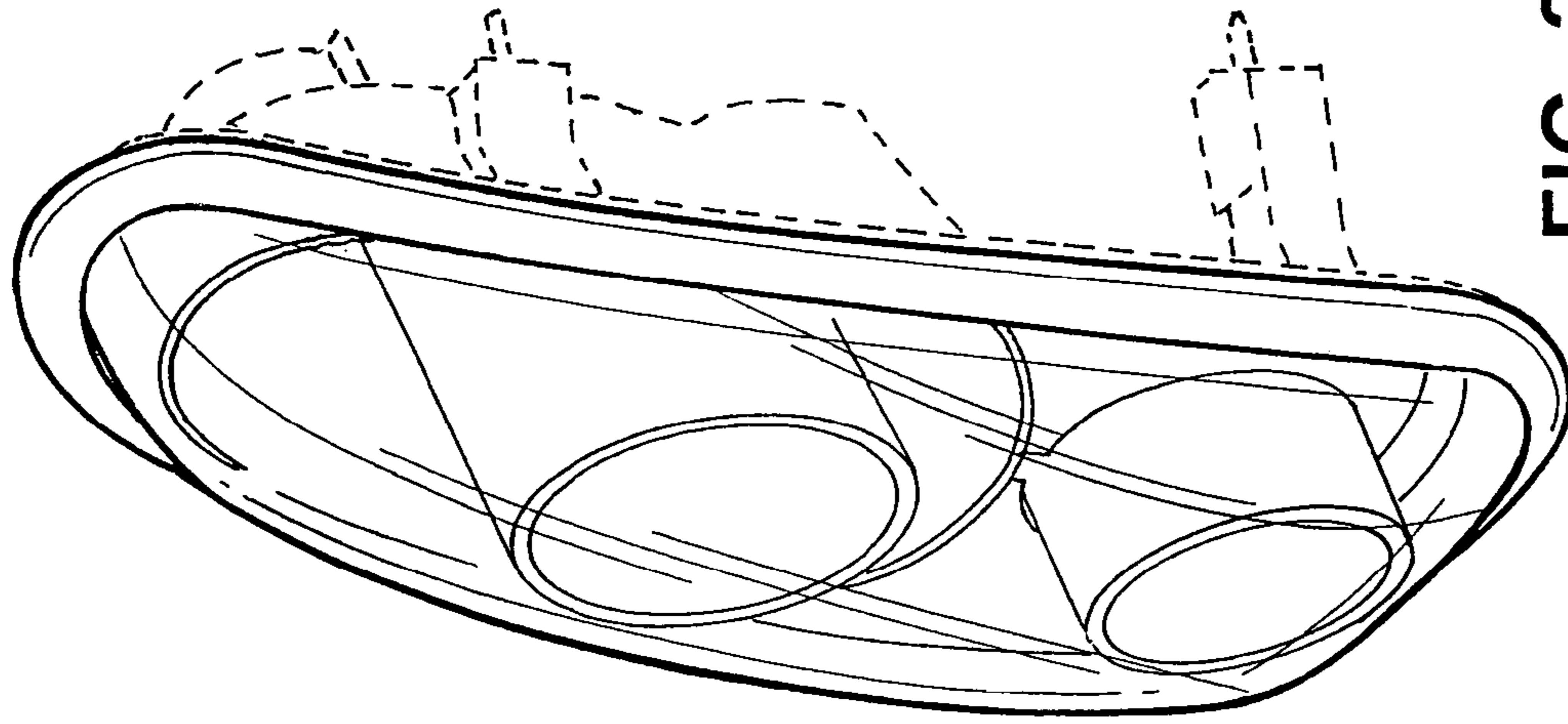

FIG. 2

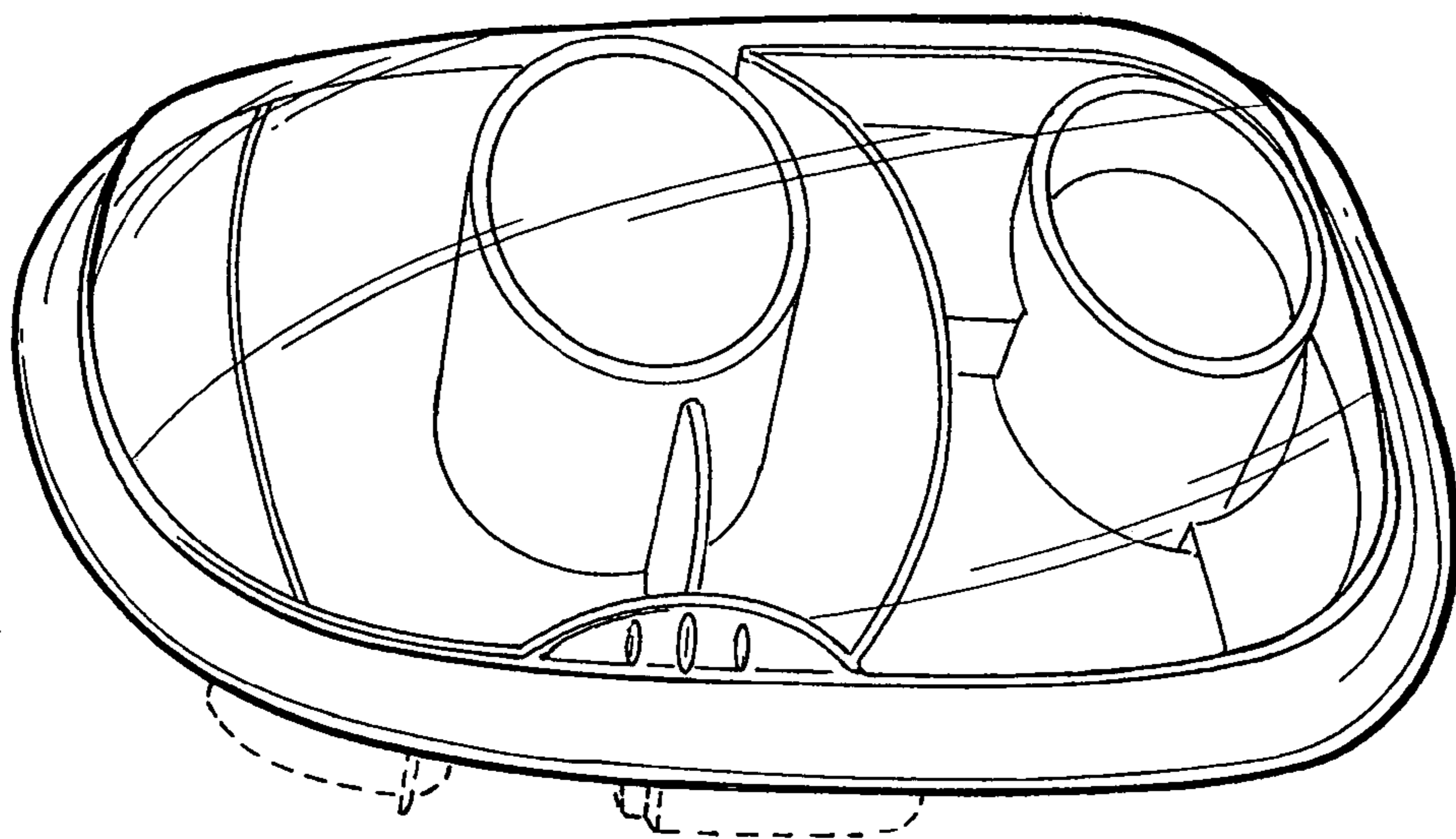

FIG. 1

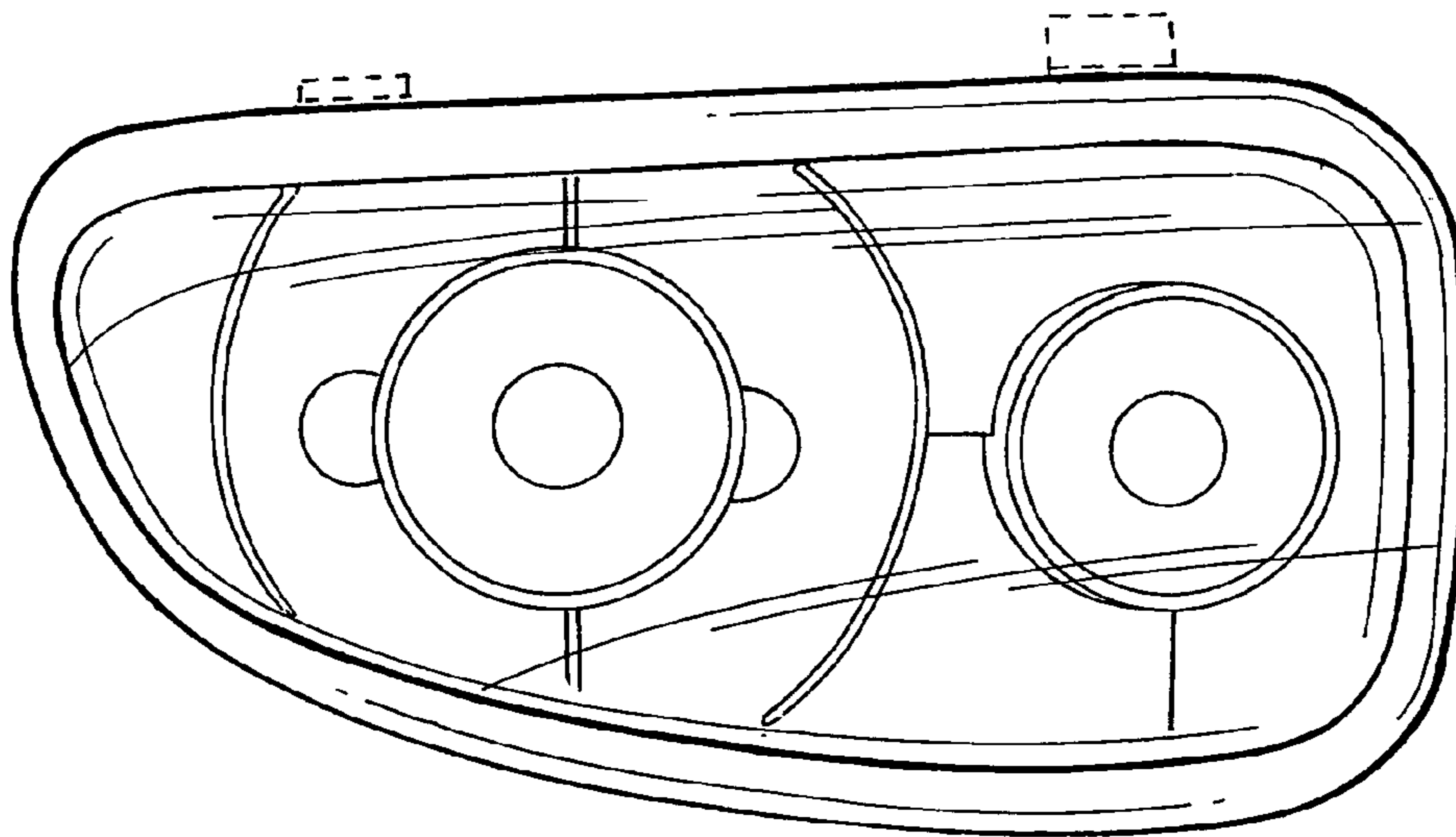

FIG. 3

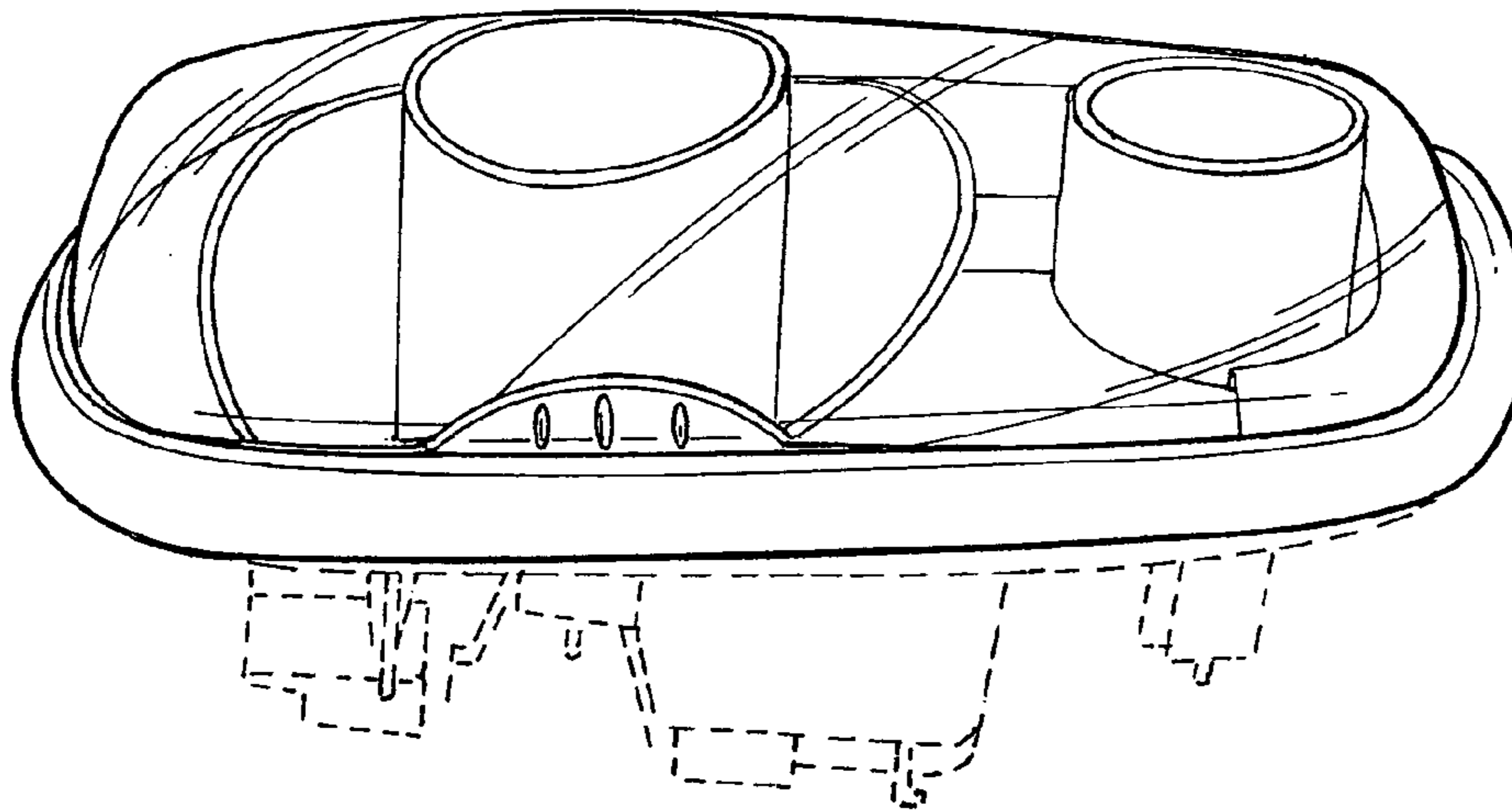

FIG. 4

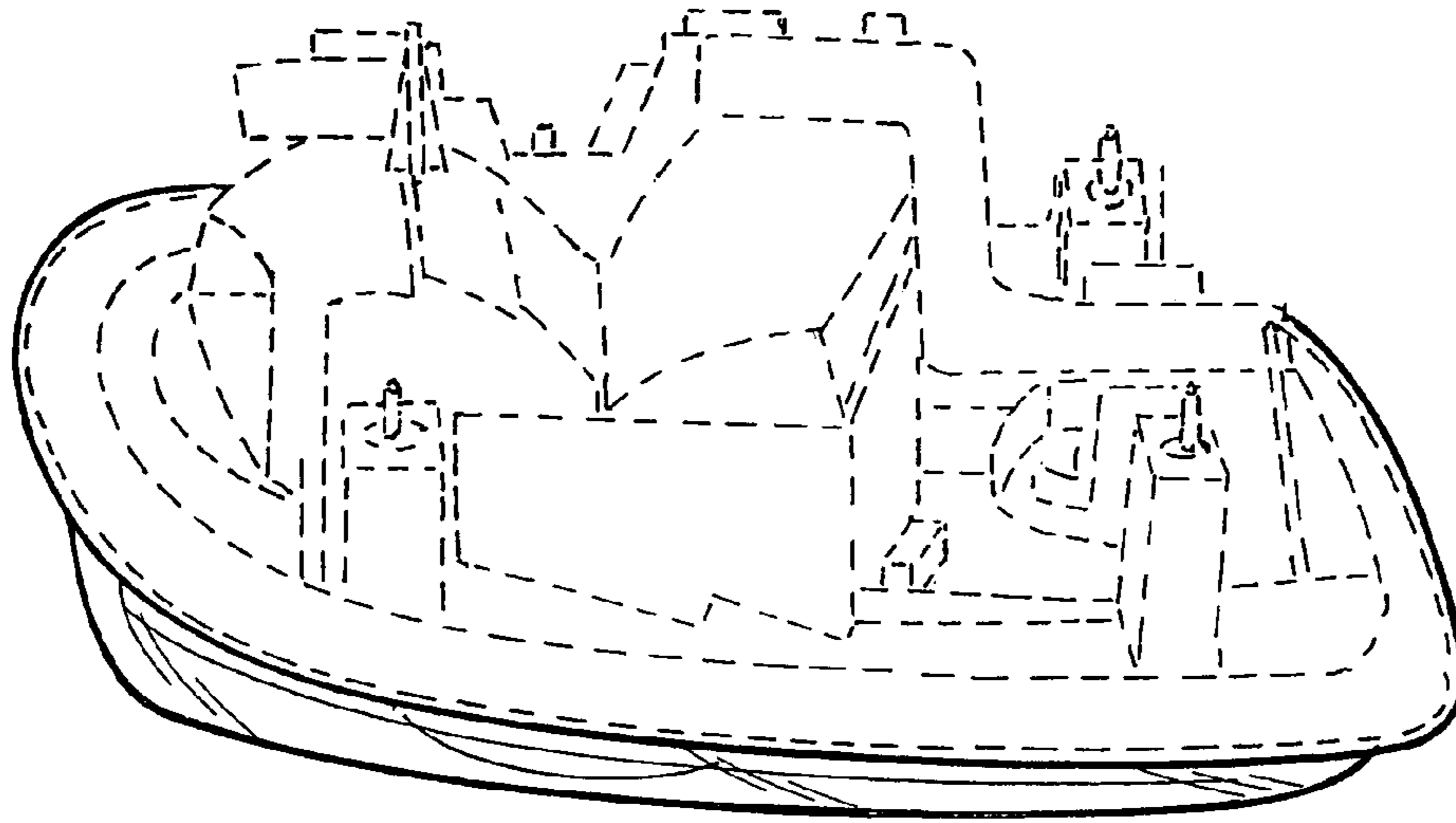
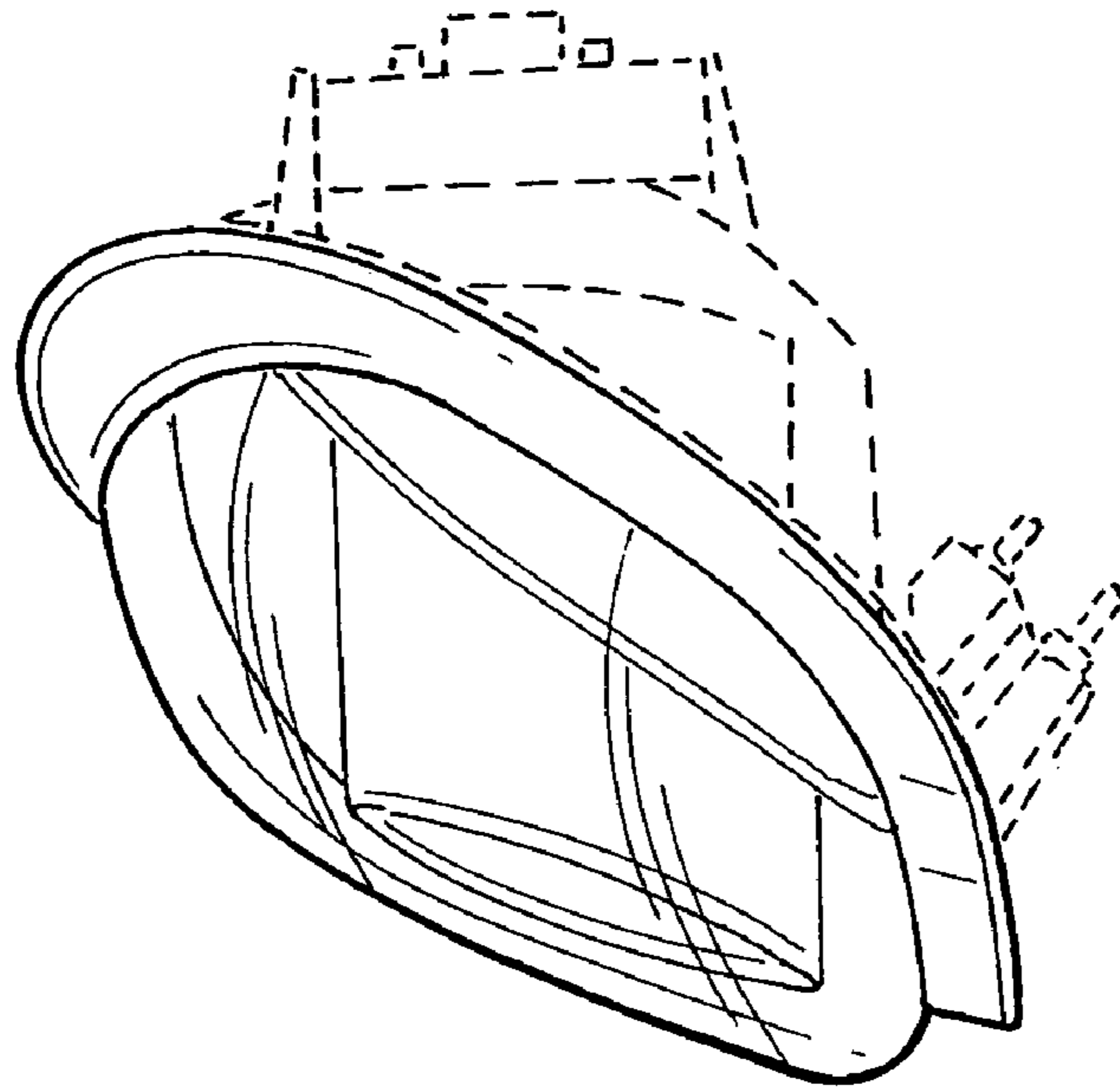
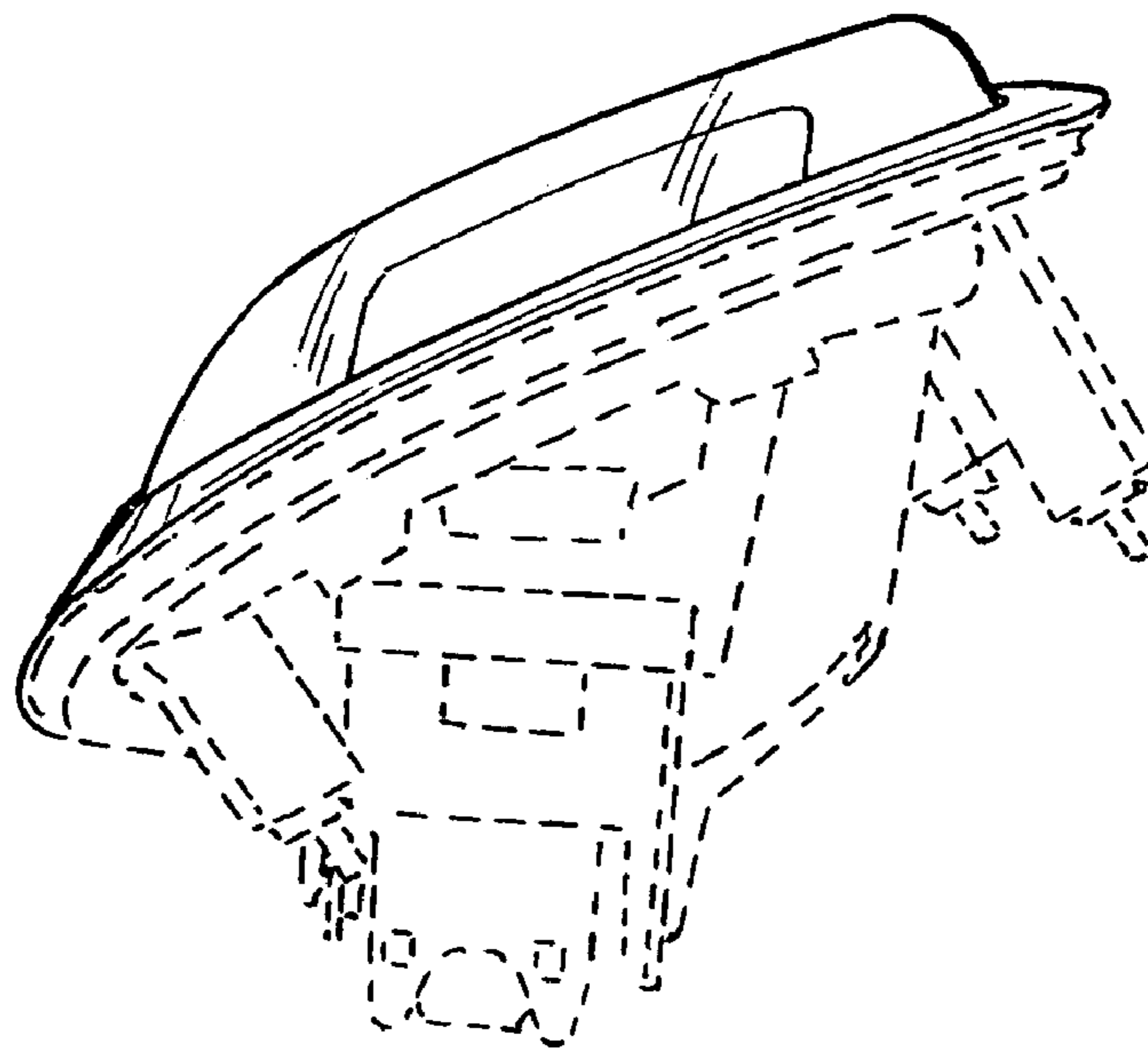

FIG. 5



**FIG. 6**



**FIG. 7**

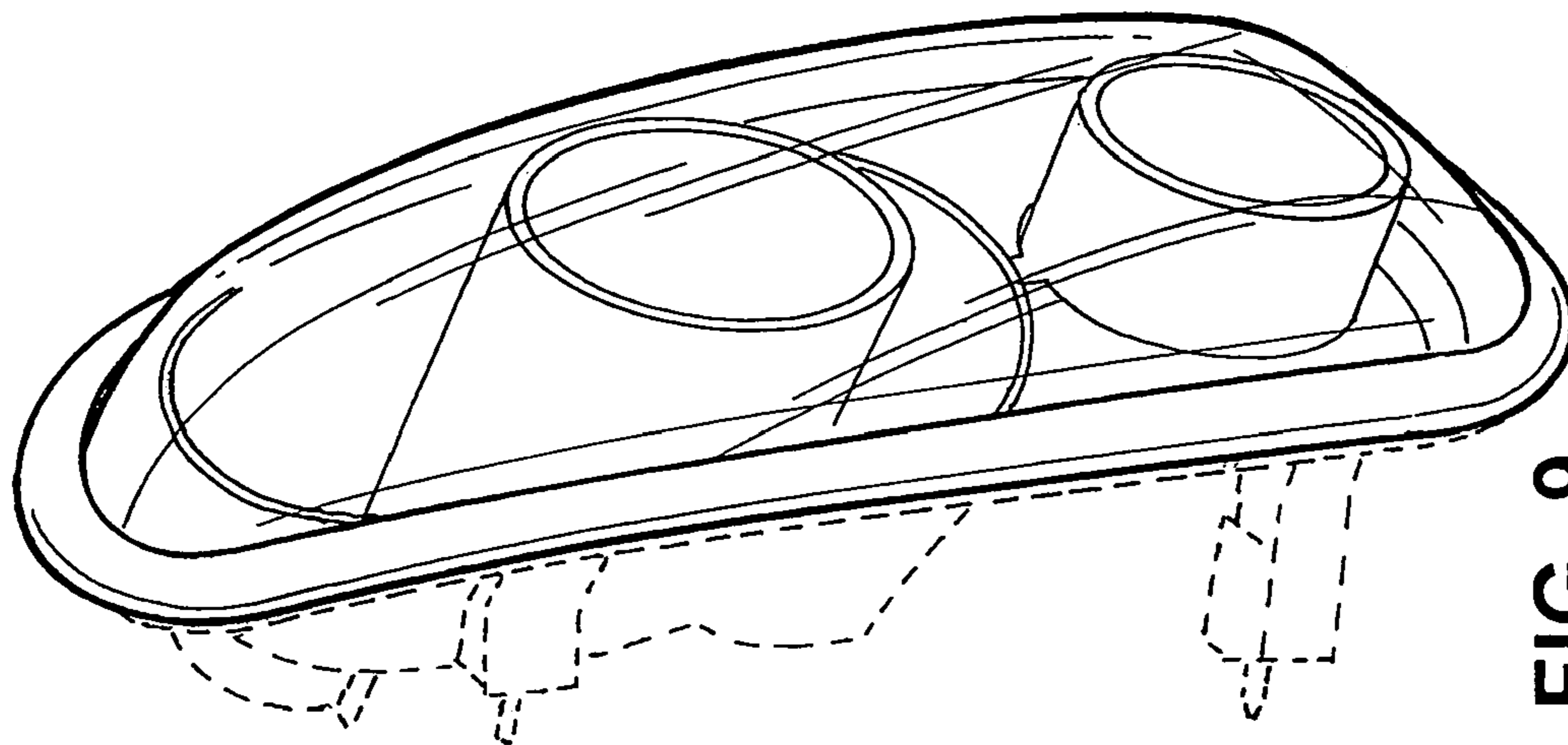

FIG. 9

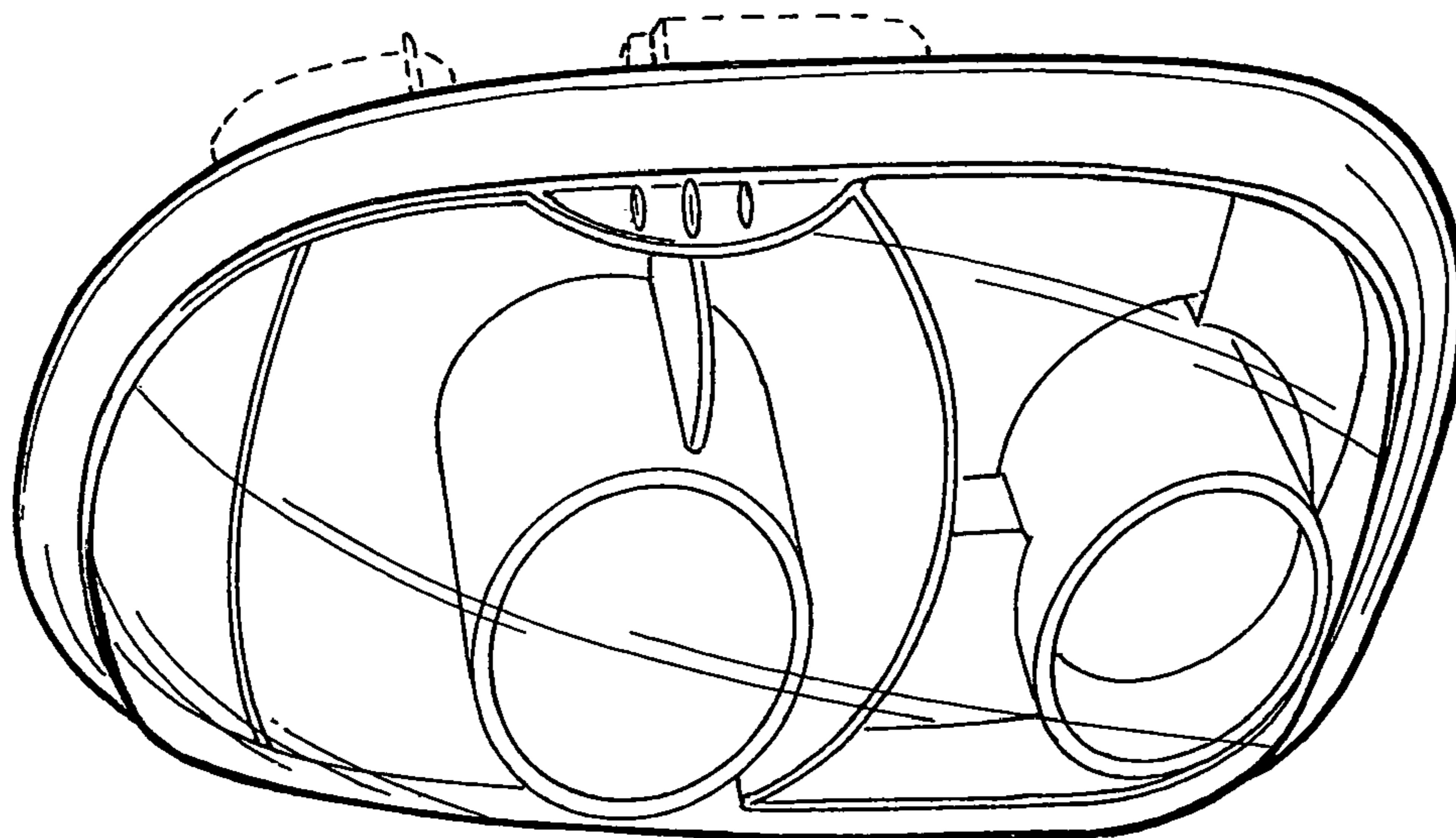

FIG. 8

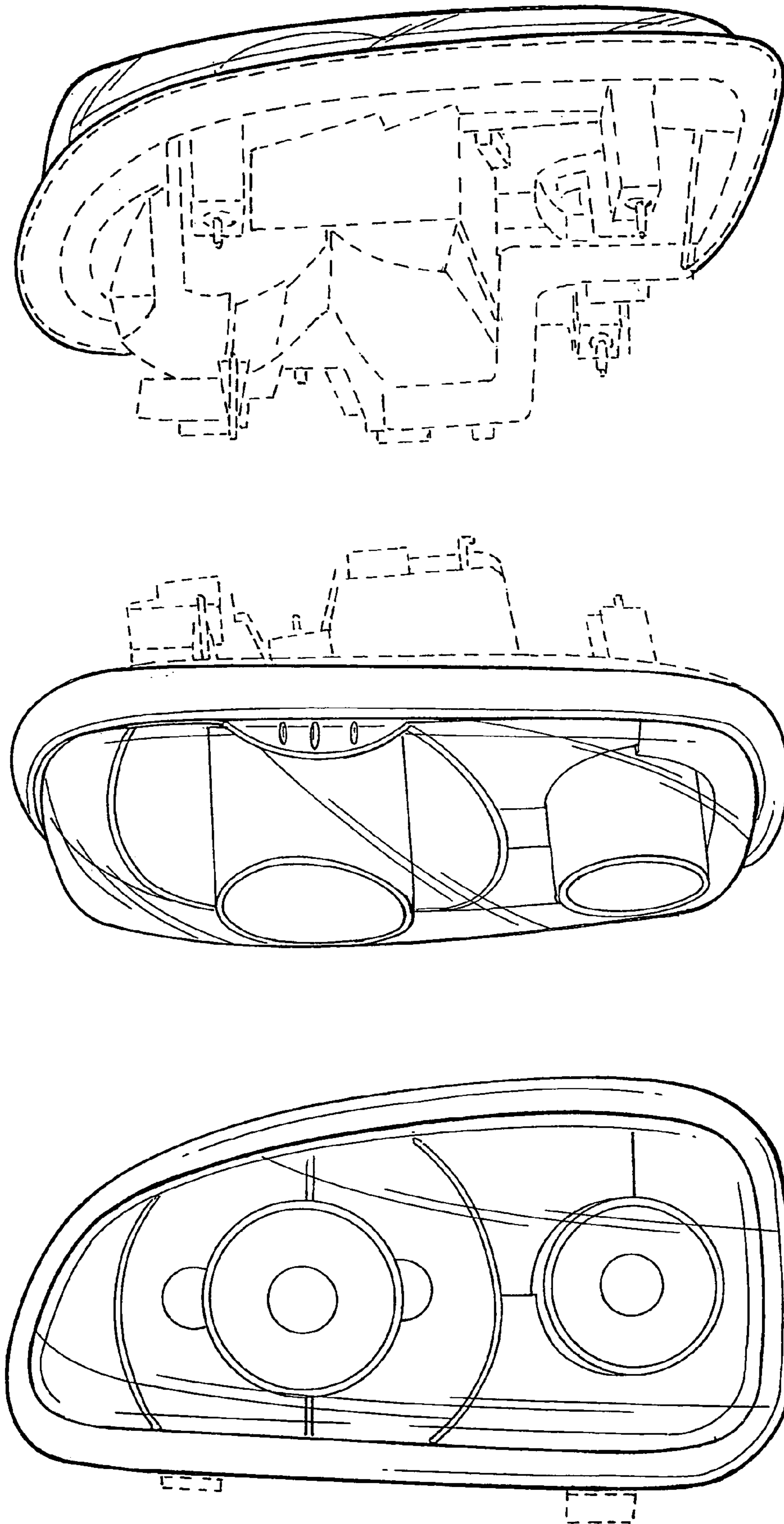
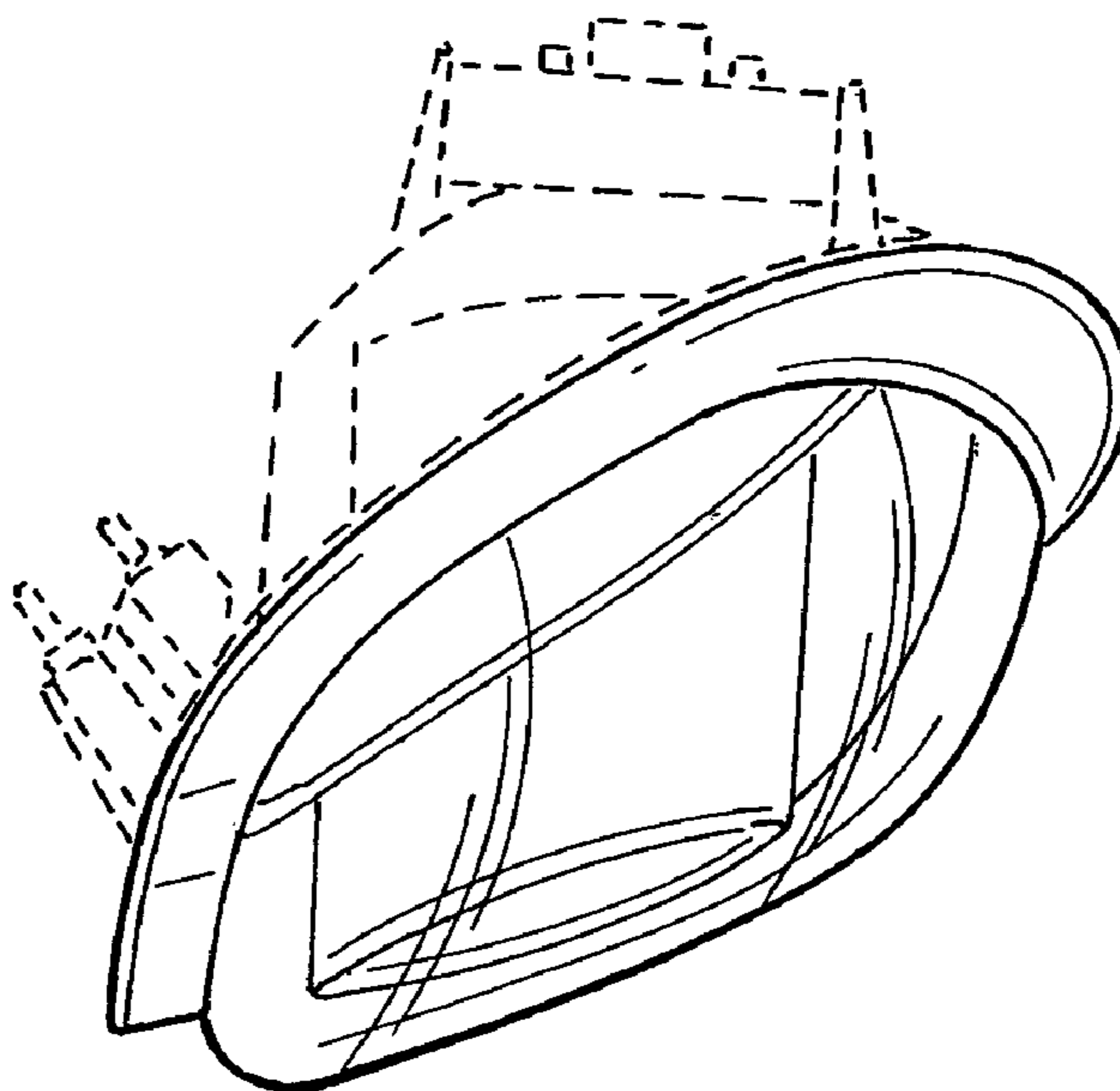

FIG. 10

FIG. 11

FIG. 12



**FIG. 13**

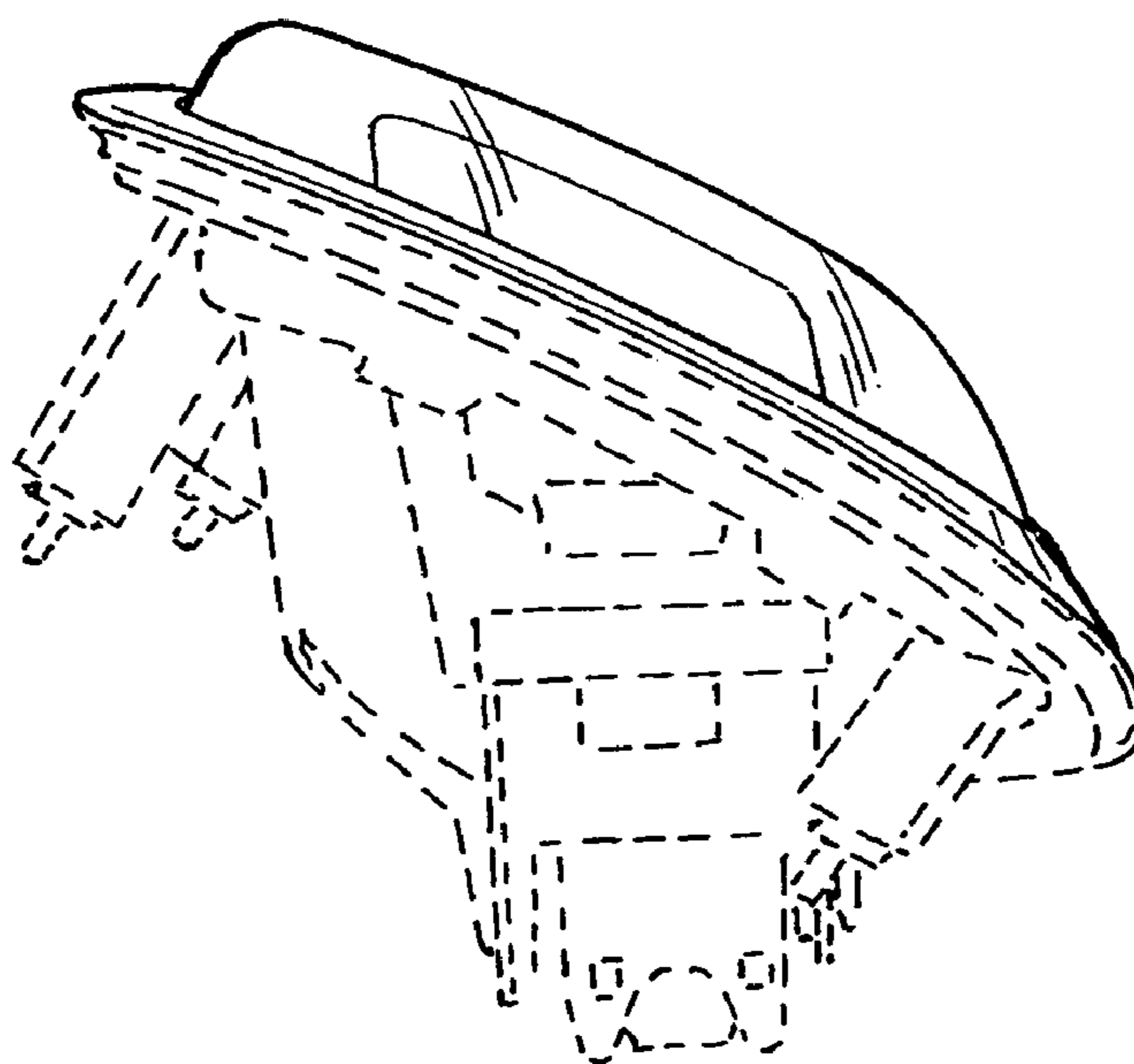

**FIG. 14**