



US00D642527S

(12) **United States Design Patent**
Li et al.

(10) **Patent No.:** **US D642,527 S**
(45) **Date of Patent:** **** Aug. 2, 2011**

(54) **ROTOR CORE FOR AN ELECTRIC MOTOR**

(75) Inventors: **Yue Li**, Hong Kong (CN); **Jian Zhao**, Shenzhen (CN); **Yong Wang**, Shenzhen (CN); **Ya Ming Zhang**, Shenzhen (CN); **Yan Hong Xue**, Hong Kong (CN); **Mao Xiong Jiang**, Shenzhen (CN)

(73) Assignee: **Johnson Electric S.A.**, Murten (CH)

(**) Term: **14 Years**

(21) Appl. No.: **29/380,093**

(22) Filed: **Nov. 30, 2010**

(30) **Foreign Application Priority Data**

May 31, 2010 (CN) 2010 3 0189040

(51) **LOC (9) Cl.** **13-01**

(52) **U.S. Cl.** **D13/122**

(58) **Field of Classification Search** D13/122,
D13/112, 114, 118, 199; D8/382; D12/180;
D15/5; 310/71, 85, 86, 156.01, 156.53, 156.56,
310/194, 216, 254.1, 262, 263; 336/198,
336/200, 208

See application file for complete search history.

(56) **References Cited**

U.S. PATENT DOCUMENTS

5,488,984 A * 2/1996 Fahy 164/91
D406,229 S * 3/1999 Lucht D8/382
6,133,662 A 10/2000 Matsunobu et al.
D441,715 S * 5/2001 Sasaki et al. D13/122

D443,585 S * 6/2001 Shida et al. D13/122
6,429,565 B1 8/2002 Matsunobu et al.
6,664,688 B2 * 12/2003 Naito et al. 310/156.01
6,674,205 B2 * 1/2004 Biais et al. 310/156.53
6,703,746 B2 * 3/2004 Biais et al. 310/156.53
6,815,858 B2 11/2004 Matsunobu et al.
6,979,924 B2 12/2005 Nishiyama et al.
7,151,335 B2 12/2006 Tajima et al.
7,230,359 B2 6/2007 Iles-Klumpner
D552,543 S * 10/2007 Su D13/122
7,474,029 B2 1/2009 Rahman et al.
7,521,832 B2 4/2009 Tajima et al.
2010/0079026 A1 4/2010 Han et al.

* cited by examiner

Primary Examiner — Stella Reid

Assistant Examiner — Derrick Holland

(74) *Attorney, Agent, or Firm* — Muncy, Geissler, Olds & Lowe, PLLC

(57) **CLAIM**

The ornamental design for a rotor core for an electric motor, as shown and described.

DESCRIPTION

FIG. 1 is a front elevation view of a rotor core for an electric motor showing our new design, the rear being a mirror image; FIG. 2 is a right side elevation view thereof, the left side being a mirror image; FIG. 3 is a top plan view thereof, the bottom plan being a mirror image; and, FIG. 4 is a front perspective view thereof, the rear perspective being a mirror image.

1 Claim, 4 Drawing Sheets

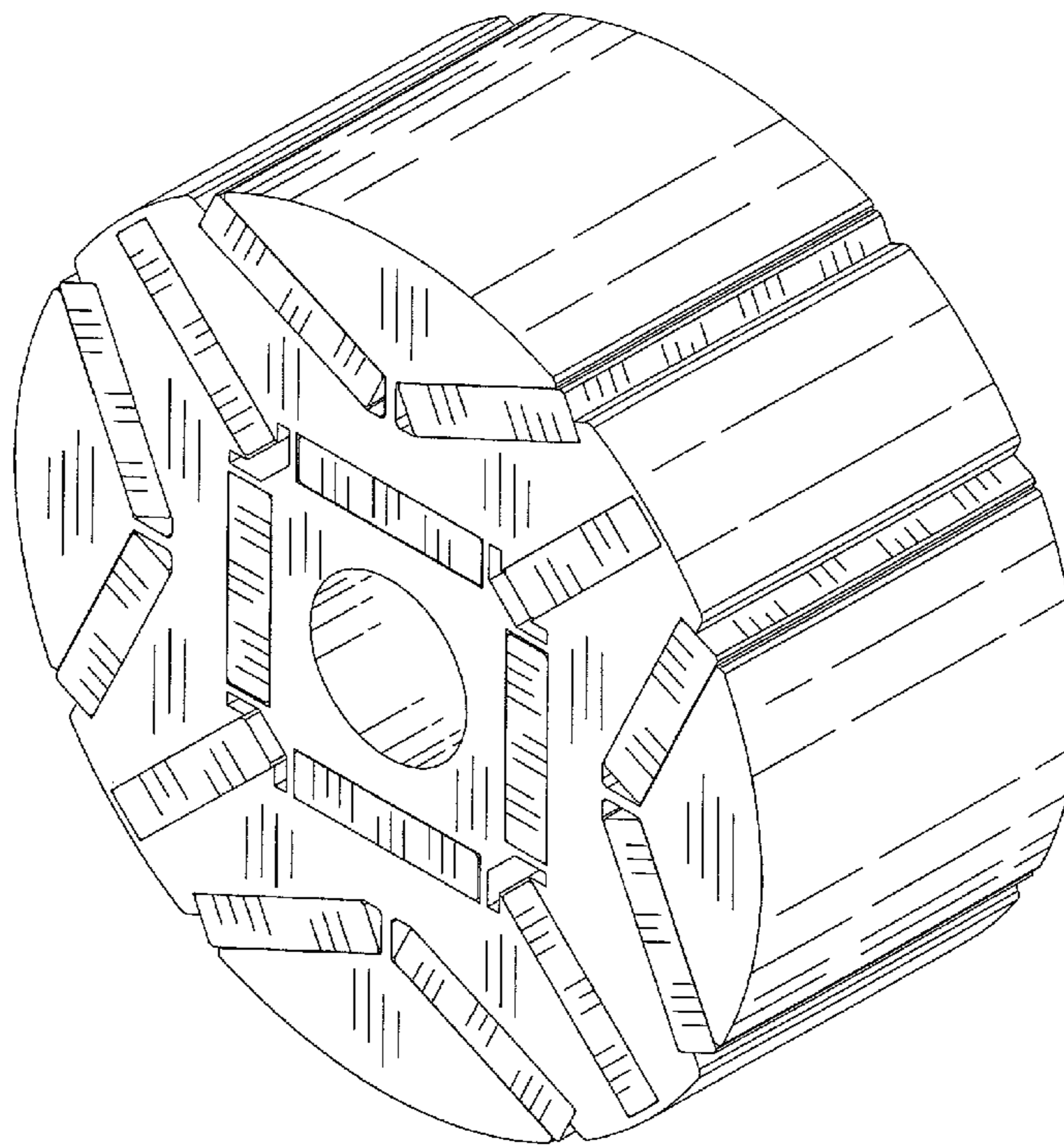

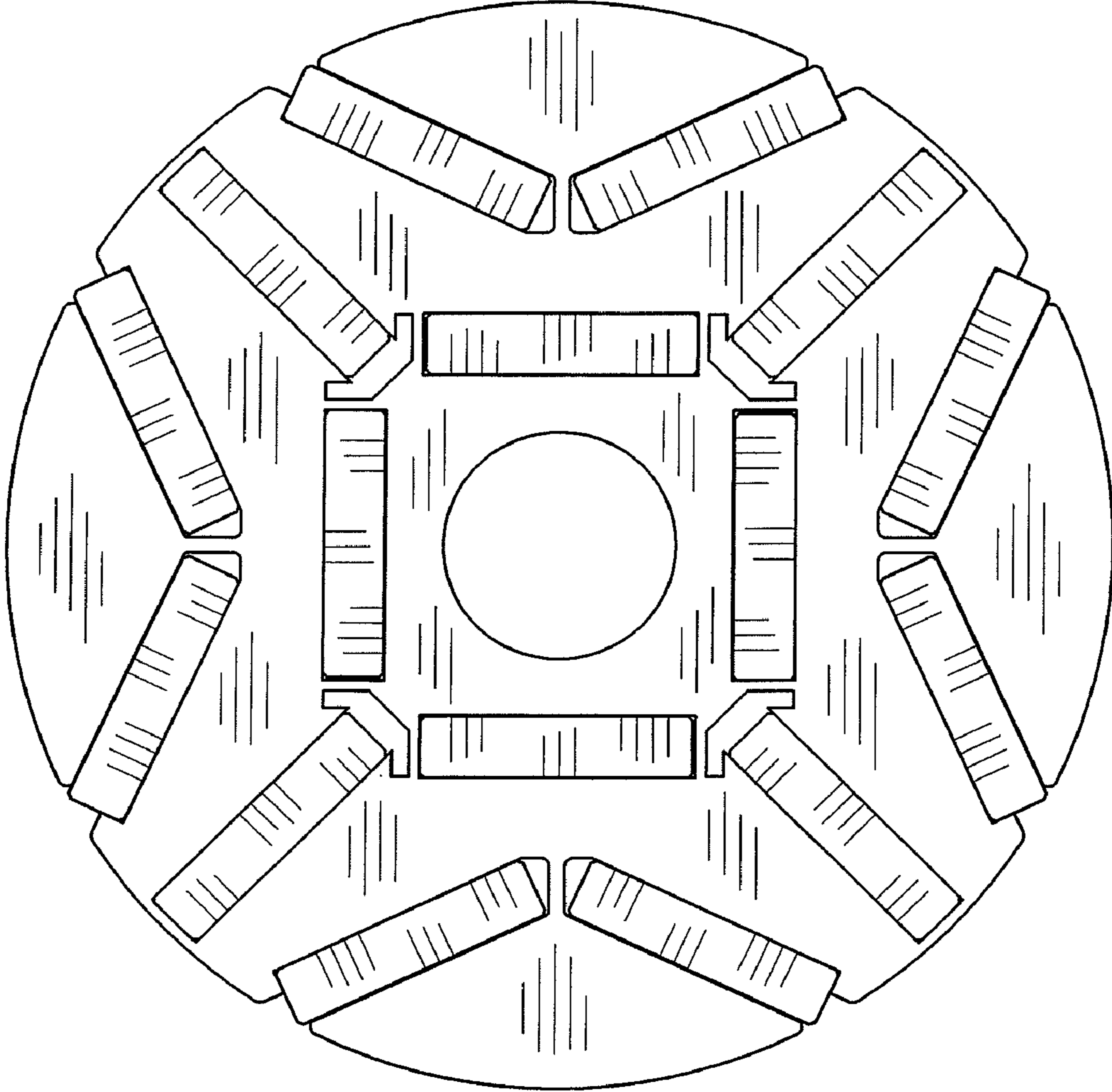

FIG. 1

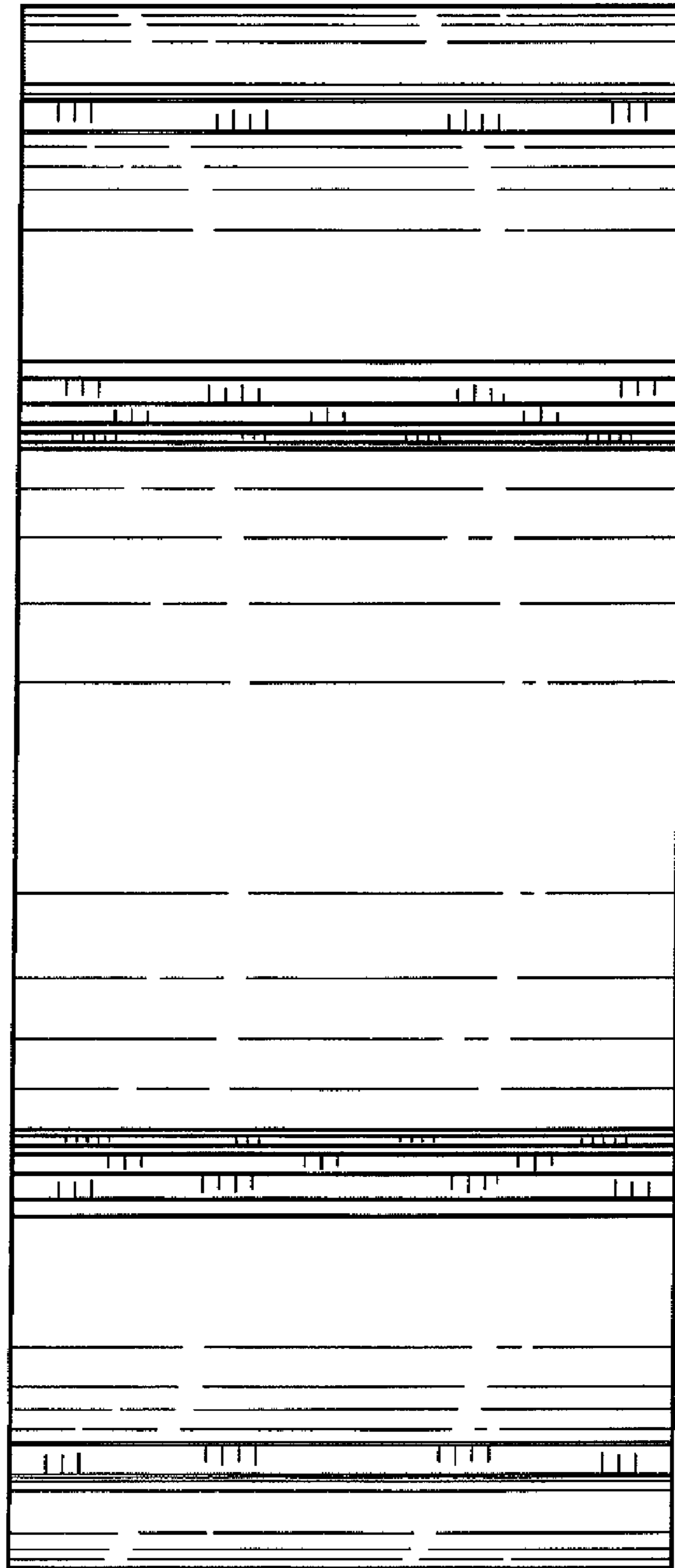

FIG. 2

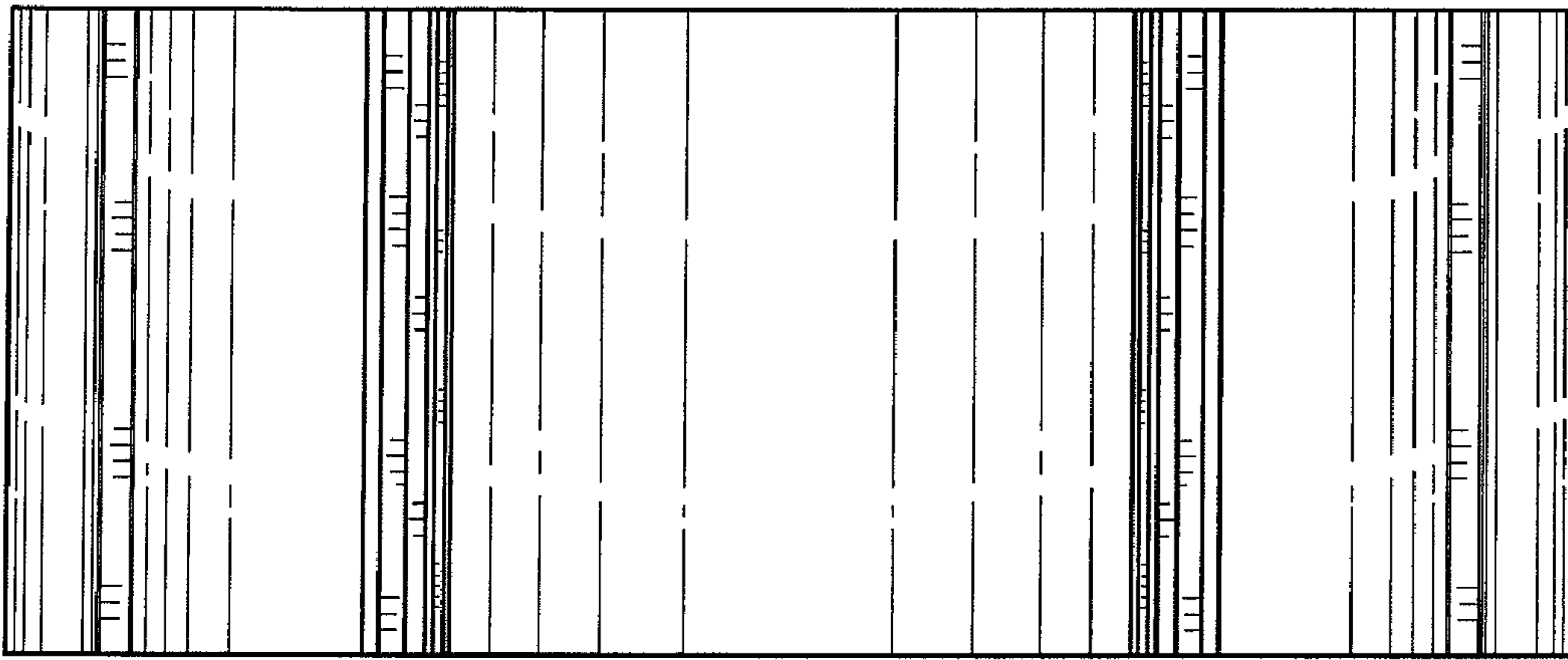

FIG. 3

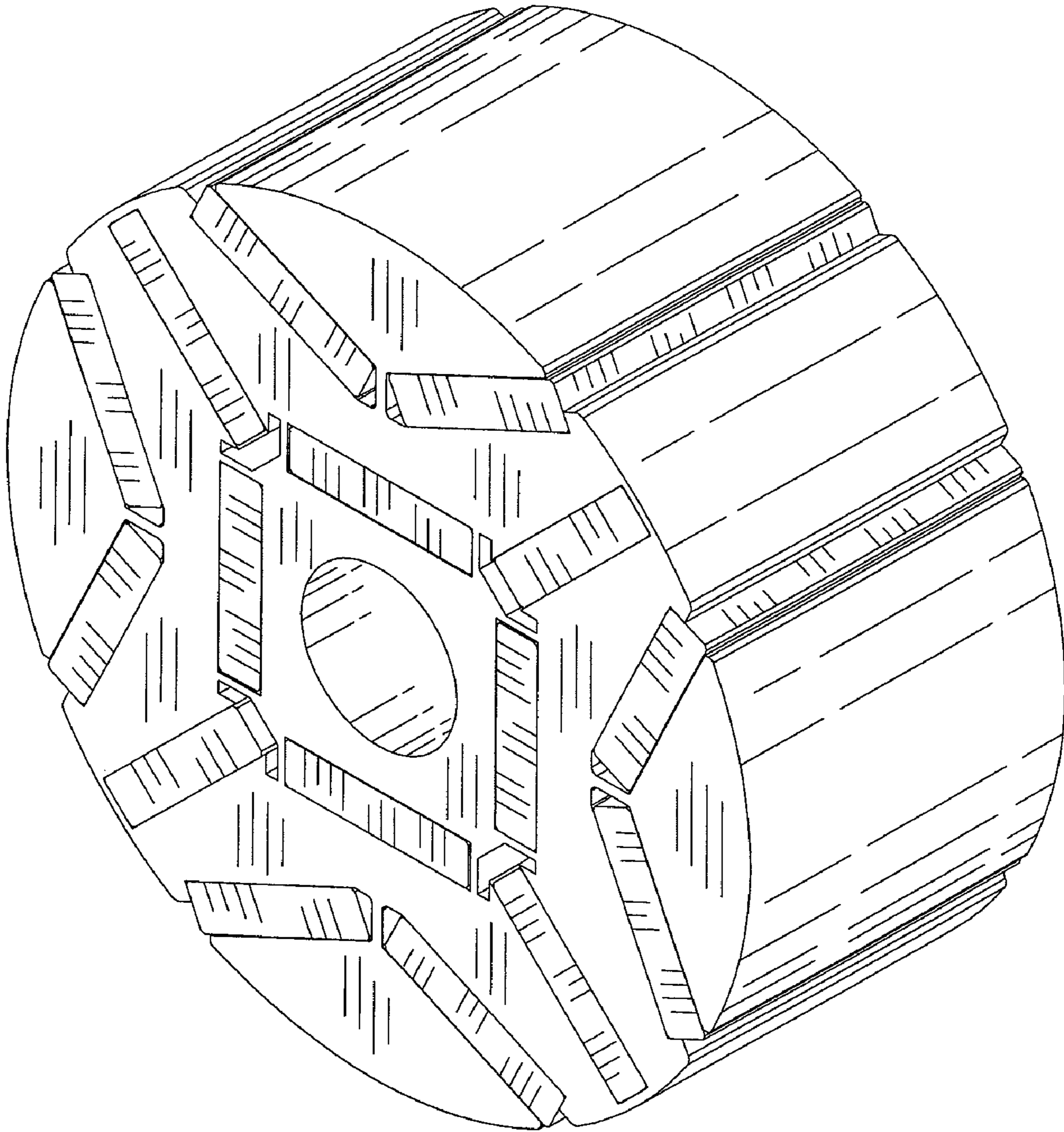

FIG. 4