



US00D642505S

(12) **United States Design Patent**
Nakajima et al.

(10) **Patent No.:** **US D642,505 S**

(45) **Date of Patent:** **** Aug. 2, 2011**

(54) **INSTRUMENT PANEL FOR AN
AUTOMOBILE**

D596,096 S * 7/2009 Mori D12/192
7,862,098 B2 * 1/2011 Biggs et al. 296/37.8
2009/0146446 A1 * 6/2009 Sutou et al. 296/70

(75) Inventors: **Takayuki Nakajima**, Toyota (JP);
Yasukazu Honda, Toyota (JP)

OTHER PUBLICATIONS

Honda Fit, Honda, Konnpact Car No Subete 2009, San-eishobo Publishing Co., Ltd, Oct. 26, 2008.

Fiat 500, Fiat, Konnpact Car No Subete 2009, San-eishobo Publishing Co., Ltd, Oct. 26, 2008.

(73) Assignee: **Toyota Jidosha Kabuhiki Kaisha** (JP)

(**) Term: **14 Years**

* cited by examiner

(21) Appl. No.: **29/368,650**

Primary Examiner — Caron D Veynar

(22) Filed: **Aug. 26, 2010**

Assistant Examiner — Katrina Kile

(51) **LOC (9) Cl.** **12-16**

(74) *Attorney, Agent, or Firm* — SAIDMAN DesignLaw Group

(52) **U.S. Cl.** **D12/192**

(58) **Field of Classification Search** D12/192,
D12/415, 110, 114; 280/750–752; 180/90;
296/70, 191, 190.01–190.09; D15/28, 17;
D10/122–127, 102–103, 98, 46
See application file for complete search history.

(57) **CLAIM**

The ornamental design for an instrument panel for an automobile, as shown and described.

(56) **References Cited**

DESCRIPTION

U.S. PATENT DOCUMENTS

D285,915 S * 9/1986 Luthe et al. D12/192
5,639,116 A * 6/1997 Shimizu et al. 280/732
5,951,045 A * 9/1999 Almfelt et al. 280/748
D449,263 S * 10/2001 Yamazaki et al. D12/192
D493,756 S * 8/2004 Yamamoto et al. D12/192
D499,998 S * 12/2004 Tanaka et al. D12/192
D532,353 S * 11/2006 Honda et al. D12/192
D577,642 S * 9/2008 Kitajima et al. D12/192

FIG. 1 is a front, perspective view of an instrument panel for an automobile showing our new design;
FIG. 2 is a front view thereof;
FIG. 3 is a top view thereof;
FIG. 4 is a bottom view thereof;
FIG. 5 is a right-side view thereof; and,
FIG. 6 is a left-side view thereof.

1 Claim, 3 Drawing Sheets

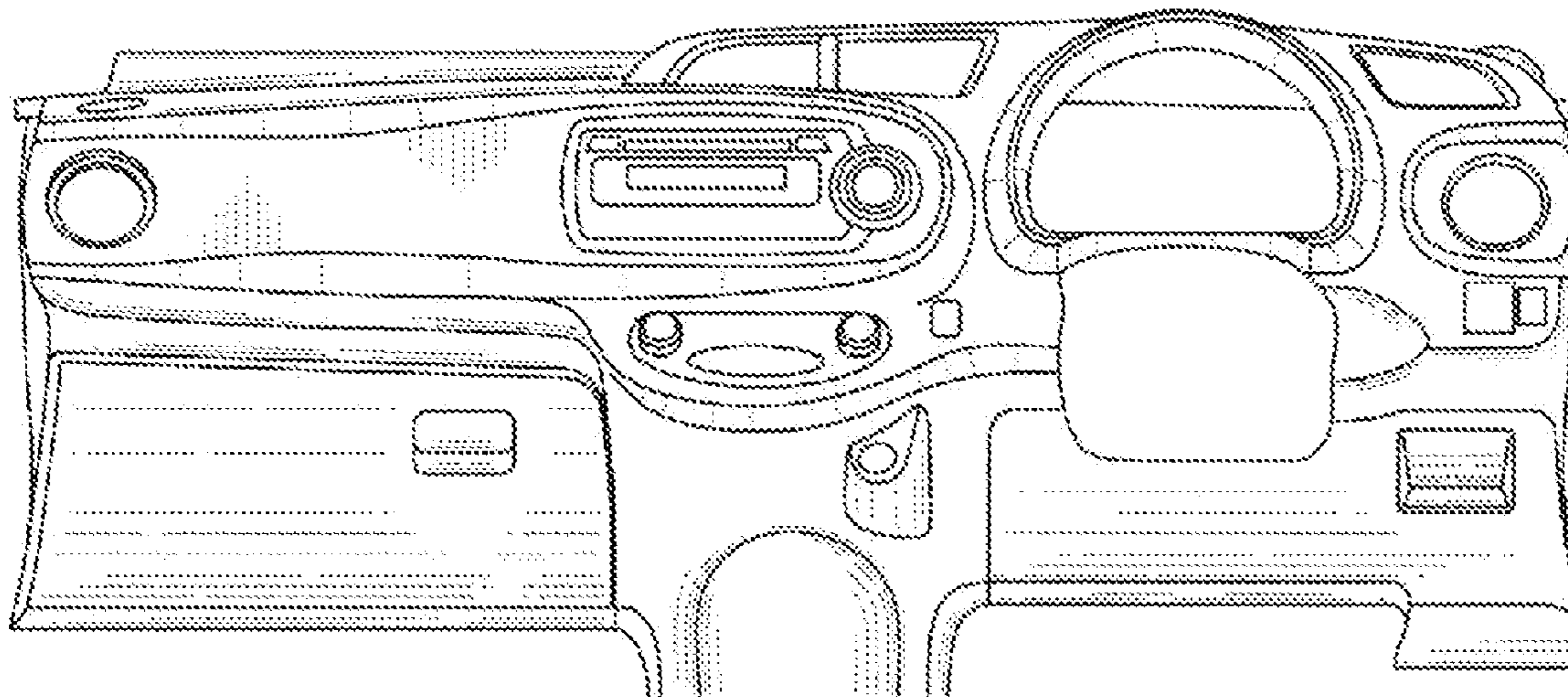

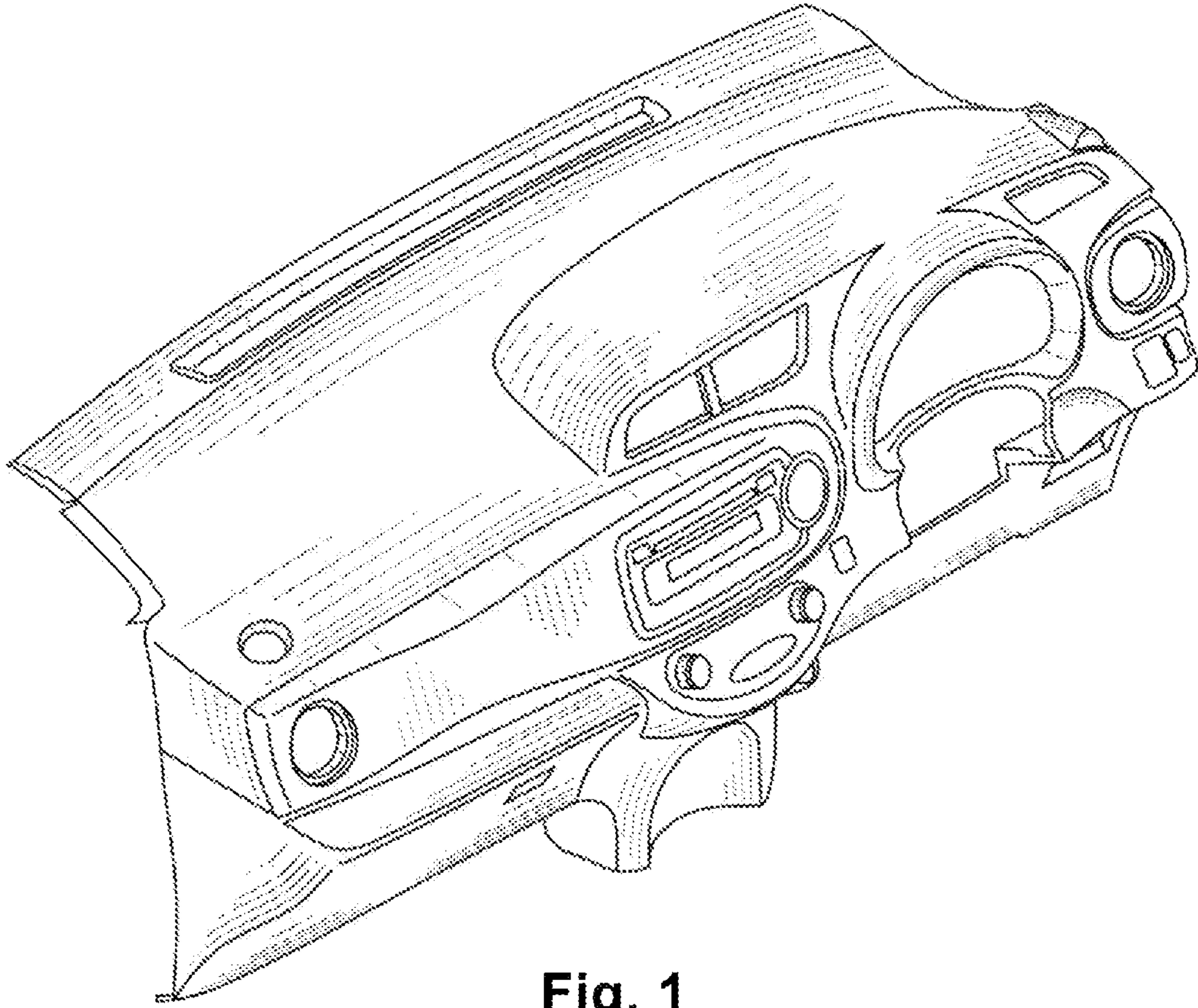

Fig. 1

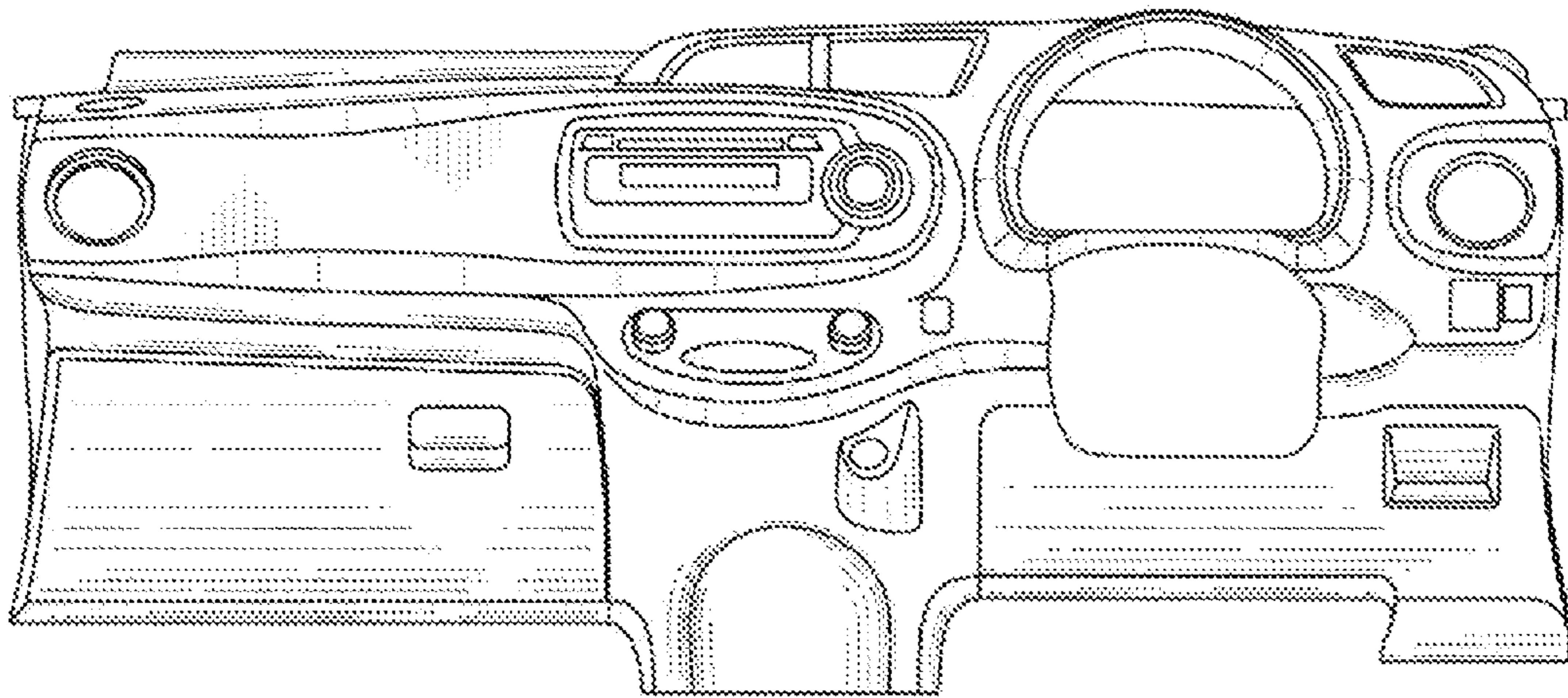

Fig. 2

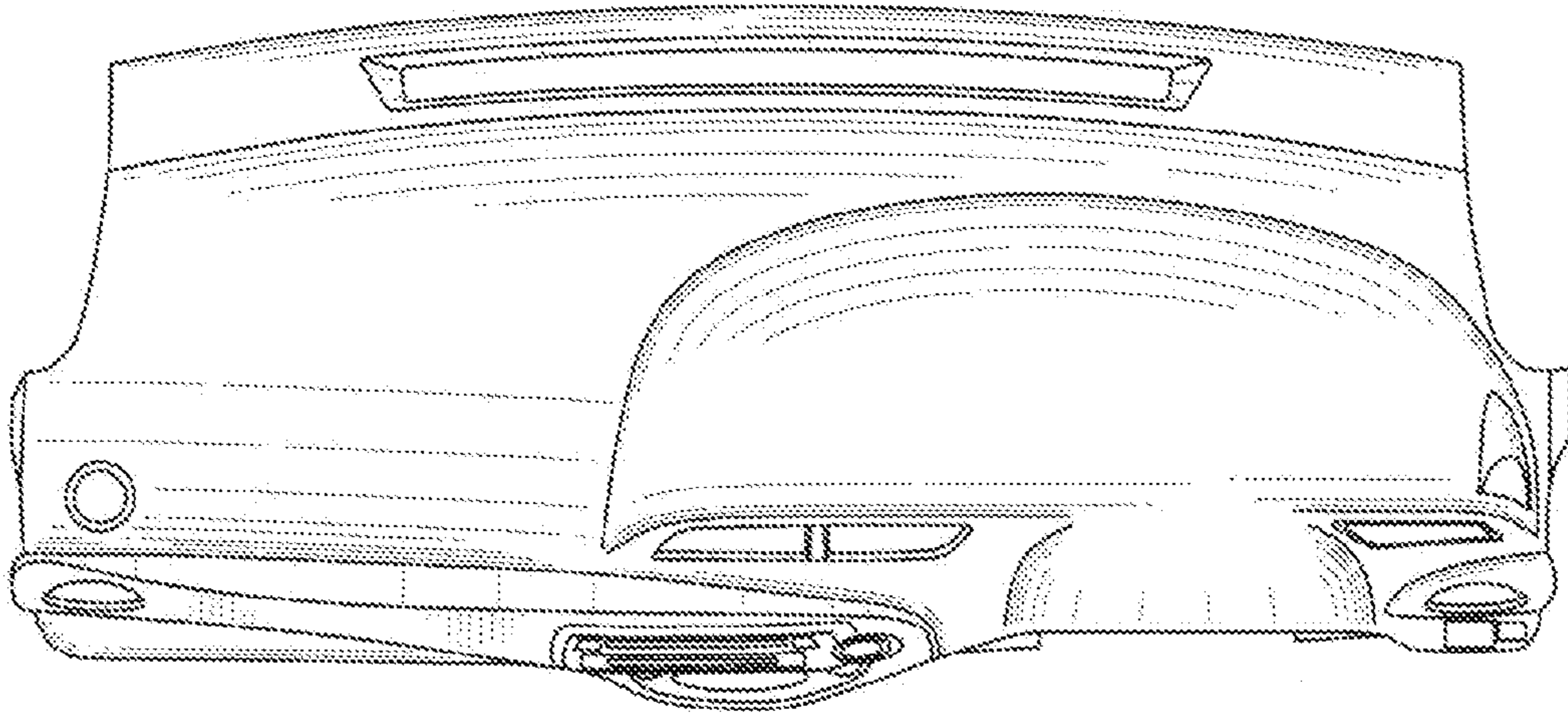

Fig. 3

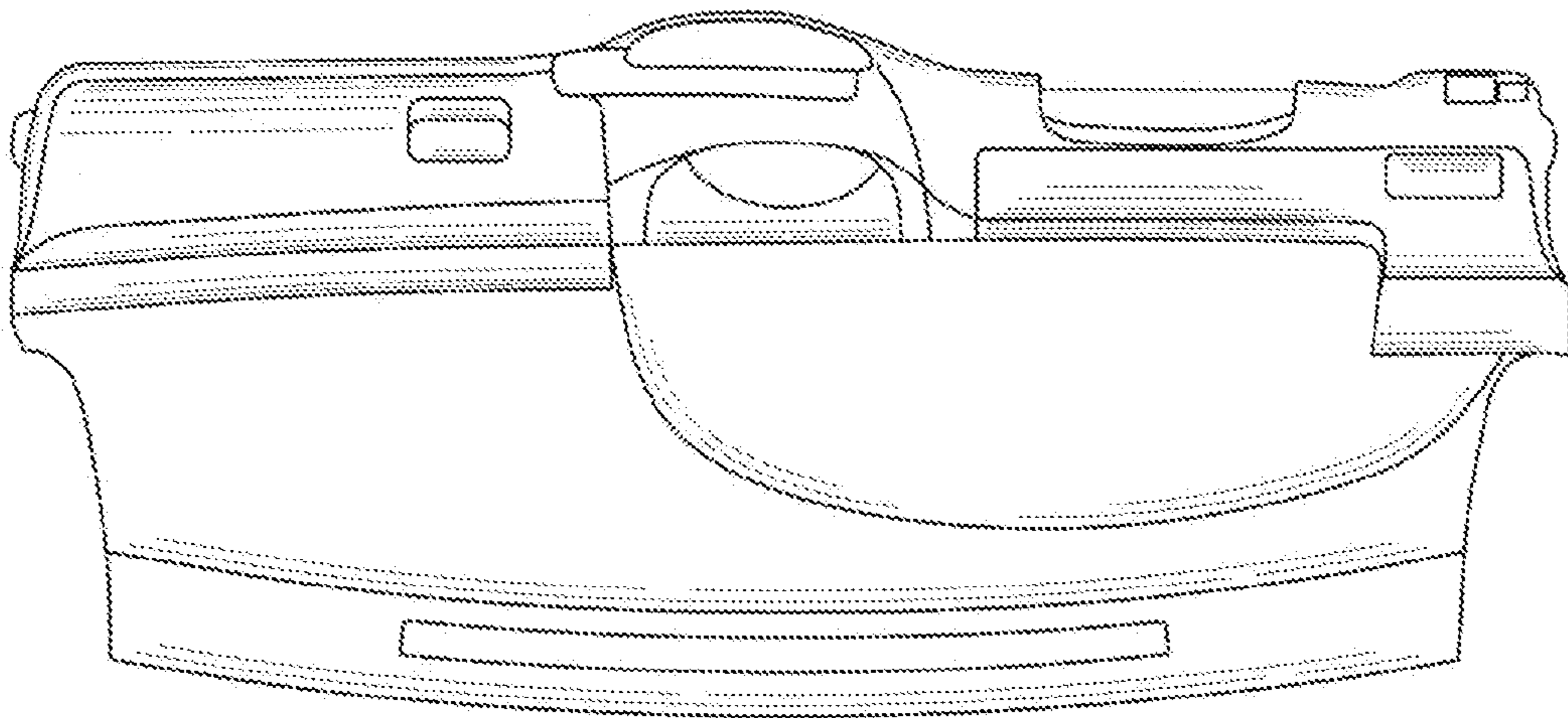

Fig. 4

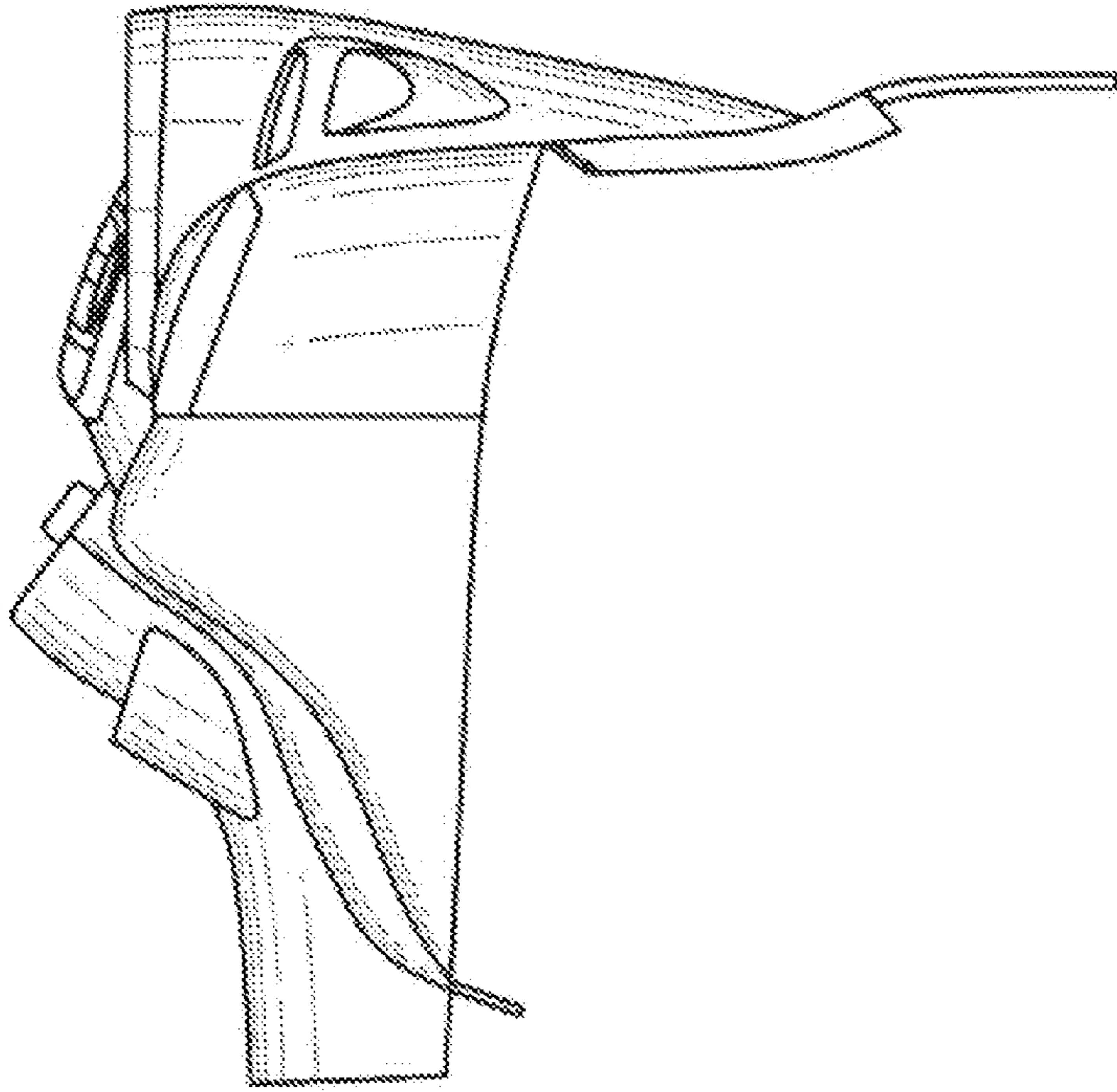

Fig. 5

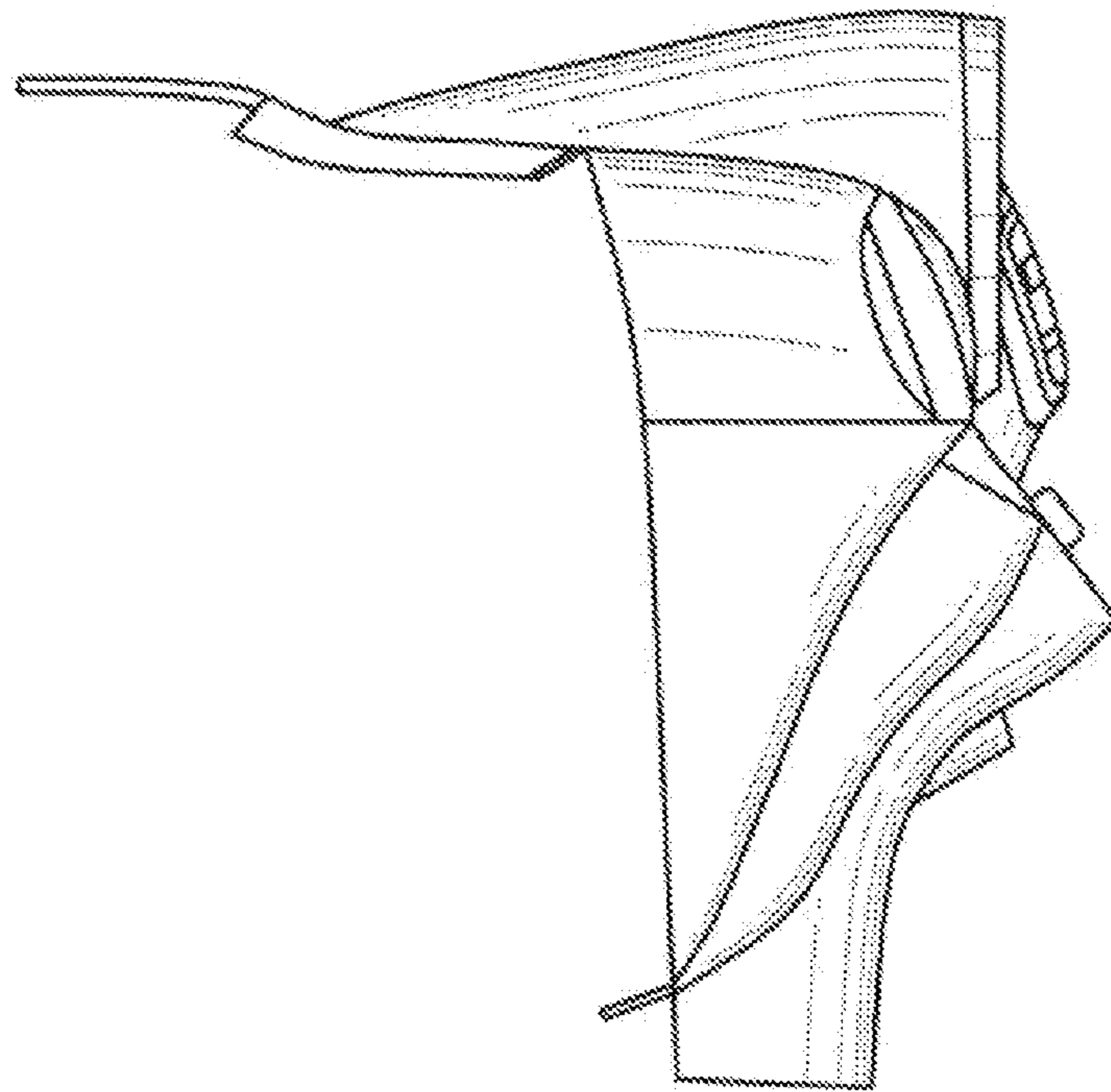

Fig. 6