



US00D642263S

(12) **United States Design Patent**
Park

(10) **Patent No.:** **US D642,263 S**

(45) **Date of Patent:** **** *Jul. 26, 2011**

(54) **ARTHROPLASTY JIG BLANK**

(75) Inventor: **Ilwhan Park**, Walnut Creek, CA (US)

(73) Assignee: **OtisMed Corporation**, Alameda, CA (US)

(**) Term: **14 Years**

(21) Appl. No.: **29/296,687**

(22) Filed: **Oct. 25, 2007**

(51) **LOC (9) Cl.** **24-02**

(52) **U.S. Cl.** **D24/140**

(58) **Field of Classification Search** D24/140,
D24/146, 143, 155; D15/133; 606/79, 82,
606/86-89; 33/511, 512, 562, 566

See application file for complete search history.

(56) **References Cited**

U.S. PATENT DOCUMENTS

3,195,411 A 7/1965 MacDonald et al.

(Continued)

FOREIGN PATENT DOCUMENTS

DE 3305237 2/1983

(Continued)

OTHER PUBLICATIONS

International Search Report and Written Opinion, International Patent Application No. PCT/US2008/083125, dated Mar. 9, 2009, 13 pages.

(Continued)

Primary Examiner — Ian Simmons

Assistant Examiner — Carissa C Fitts

(74) *Attorney, Agent, or Firm* — Polsinelli Shughart PC

(57) **CLAIM**

I claim the ornamental design for an arthroplasty jig blank, as shown and described.

DESCRIPTION

This application is related to U.S. Utility patent application Ser. No. 11/924,425 entitled "Arthroplasty Systems and Devices, and Related Methods", filed concurrently herewith, and incorporated herein by reference in its entirety.

FIG. 1 is a front perspective view of a left femoral jig blank of an arthroplasty jig blank according to a first variant of the present design;

FIG. 2 is a rear perspective view of the left femoral jig blank of FIG. 1;

FIG. 3 is a front view elevational of the left femoral jig blank of FIG. 1

FIG. 4 is a rear elevational view of the left femoral jig blank of FIG. 1;

FIG. 5 is a top plan view of the left femoral jig blank of FIG. 1;

FIG. 6 is a bottom plan view of the left femoral jig blank of FIG. 1;

FIG. 7 is a right side elevational view of the left femoral jig blank of FIG. 1;

FIG. 8 is a rear left side elevational view of the left femoral jig blank of FIG. 1;

FIG. 9 is bottom perspective view of the left femoral jig blank of FIG. 1;

FIG. 10 is a right side, front perspective view of the left femoral jig blank of FIG. 1;

FIG. 11 is a front elevational view of a right femoral jig blank according to a second variant of an arthroplasty jig blank, which is a mirror image of the of the left femoral jig blank of FIG. 1;

FIG. 12 is a front perspective view of the left femoral jig blank according to a third variant of an arthroplasty jig blank;

FIG. 13 is a rear perspective view of the left femoral jig blank of FIG. 12;

FIG. 14 is a front elevational view of the left femoral jig blank of FIG. 12;

FIG. 15 is a rear elevational view of the left femoral jig blank of FIG. 12;

FIG. 16 is a top plan view of the left femoral jig blank of FIG. 12;

FIG. 17 is a bottom plan view of the left femoral jig blank of FIG. 12;

FIG. 18 is a right side elevational view of the left femoral jig blank of FIG. 12;

FIG. 19 is a left side elevational view of the left femoral jig blank of FIG. 12; and,

FIG. 20 is a top plan view of a right femoral jig blank according to the fourth variant of an arthroplasty jig blank, which is a mirror image of the left femoral jig blank of FIG. 12.

1 Claim, 11 Drawing Sheets

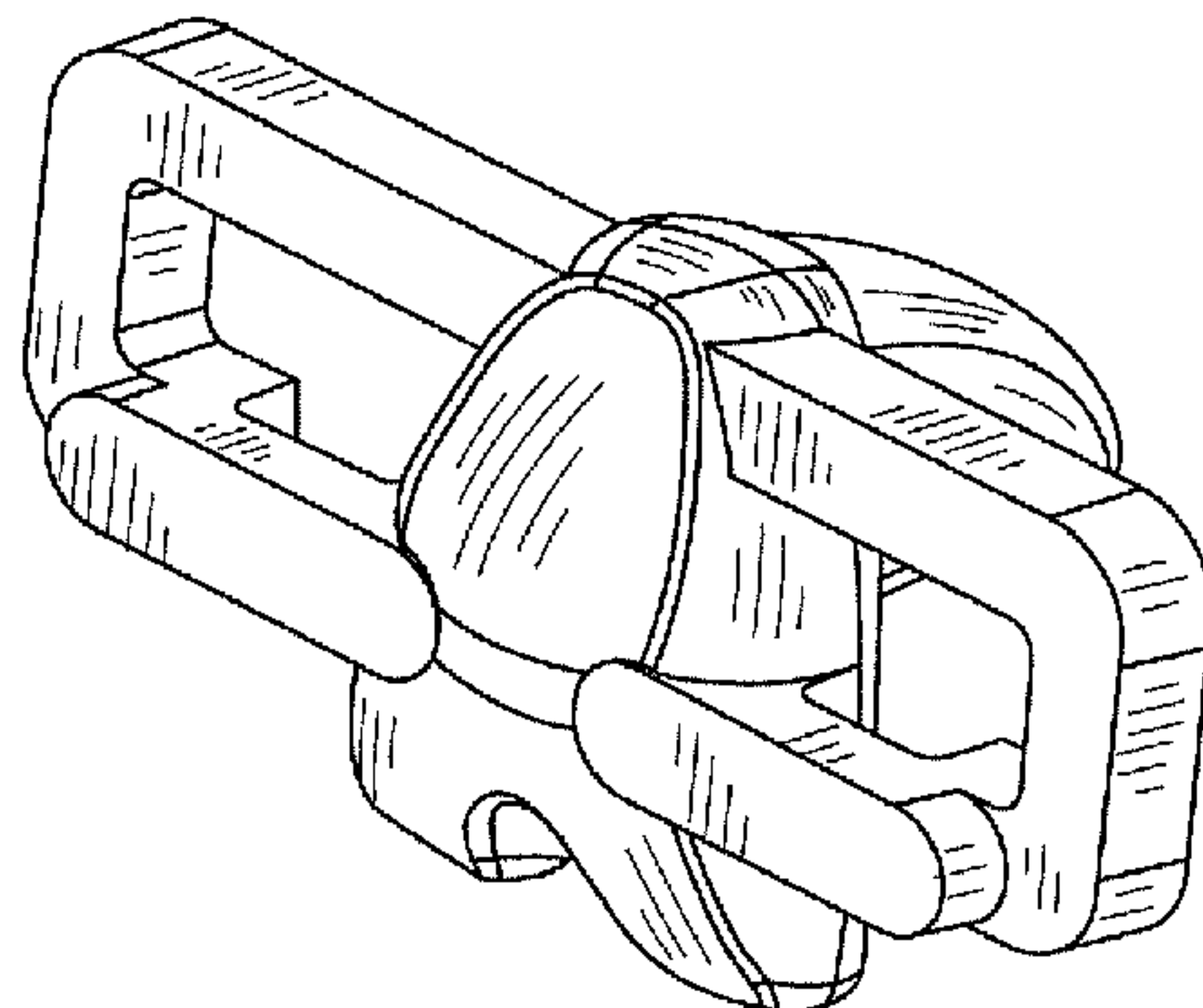
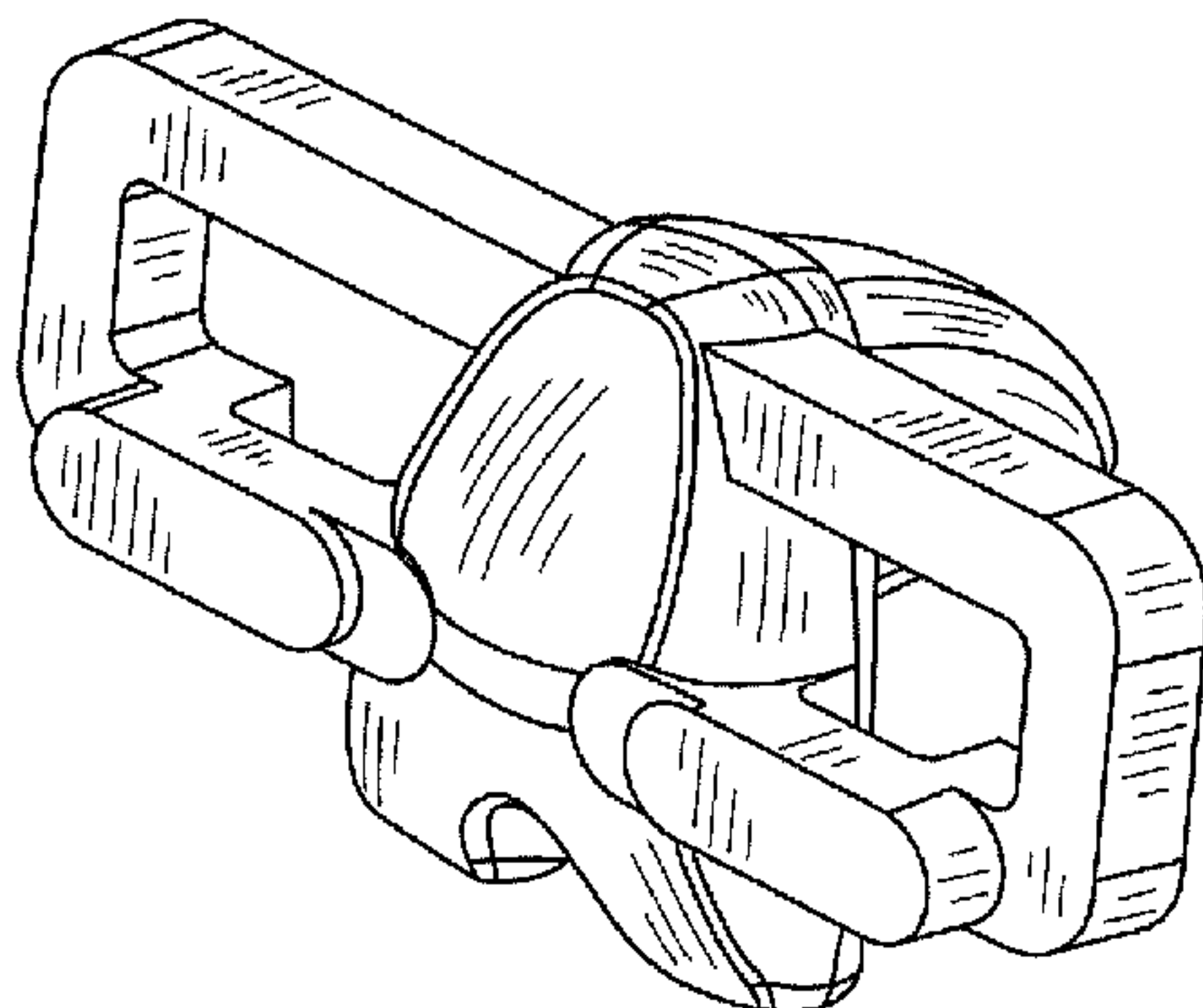

US D642,263 S

U.S. PATENT DOCUMENTS							
3,825,151	A	7/1974	Arnaud	6,503,254	B2	1/2003	Masini
D245,920	S *	9/1977	Shen D24/155	6,520,964	B2	2/2003	Tallarida et al.
4,298,992	A	11/1981	Burstein	6,575,980	B1	6/2003	Robie
4,436,684	A	3/1984	White	6,602,259	B1	8/2003	Masini
D274,093	S *	5/1984	Kenna D24/140	6,672,870	B2	1/2004	Knapp
D274,161	S *	6/1984	Kenna D24/140	6,692,448	B2	2/2004	Tanaka et al.
4,575,330	A	3/1986	Hull	6,701,174	B1	3/2004	Krause et al.
4,821,213	A	4/1989	Cline et al.	6,711,432	B1	3/2004	Krause et al.
4,822,365	A	4/1989	Walker et al.	6,712,856	B1	3/2004	Carignan et al.
4,931,056	A	6/1990	Ghajar et al.	6,716,249	B2	4/2004	Hyde
4,936,862	A	6/1990	Walker et al.	6,738,657	B1	5/2004	Franklin et al.
5,027,281	A	6/1991	Rekow et al.	6,747,646	B2	6/2004	Gueziec et al.
5,075,866	A	12/1991	Goto et al.	6,770,099	B2	8/2004	Andriacchi et al.
5,078,719	A	1/1992	Schreiber	6,772,026	B2	8/2004	Bradbury et al.
5,098,383	A	3/1992	Hemmy et al.	6,814,575	B2	11/2004	Poirier
5,122,144	A	6/1992	Bert et al.	6,905,510	B2	6/2005	Saab
5,123,927	A	6/1992	Duncan et al.	6,905,514	B2	6/2005	Carignan et al.
5,140,646	A	8/1992	Ueda	6,923,817	B2	8/2005	Carson et al.
5,156,777	A	10/1992	Kaye	6,932,842	B1	8/2005	Litschko et al.
5,171,276	A	12/1992	Caspari et al.	6,944,518	B2	9/2005	Roose
D336,518	S *	6/1993	Taylor D24/143	6,969,393	B2	11/2005	Pinczewski et al.
5,218,427	A	6/1993	Koch	6,975,894	B2	12/2005	Wehrli et al.
5,234,433	A	8/1993	Bert et al.	6,978,188	B1	12/2005	Christensen
5,274,565	A	12/1993	Reuben	7,029,479	B2	4/2006	Tallarida et al.
5,298,115	A	3/1994	Leonard	7,039,225	B2	5/2006	Tanaka et al.
D346,979	S *	5/1994	Stalcup et al. D10/64	7,060,074	B2	6/2006	Rosa et al.
5,320,529	A	6/1994	Pompa	7,074,241	B2	7/2006	McKinnon
5,360,446	A	11/1994	Kennedy	7,090,677	B2	8/2006	Fallin et al.
5,364,402	A	11/1994	Mumme et al.	RE39,301	E	9/2006	Bertin
5,365,996	A	11/1994	Crook	7,104,997	B2	9/2006	Lionberger et al.
D355,254	S *	2/1995	Krafft et al. D24/140	7,128,745	B2	10/2006	Masini
5,408,409	A	4/1995	Glassman et al.	D532,515	S *	11/2006	Buttler et al. D24/140
5,448,489	A	9/1995	Reuben	7,141,053	B2	11/2006	Rosa et al.
5,452,407	A	9/1995	Crook	7,153,309	B2	12/2006	Huebner et al.
5,462,550	A	10/1995	Dietz et al.	7,235,080	B2	6/2007	Hodorek
5,484,446	A *	1/1996	Burke et al. 606/87	7,238,190	B2	7/2007	Schon et al.
D372,309	S *	7/1996	Heldreth D24/133	7,239,908	B1	7/2007	Alexander et al.
D374,078	S *	9/1996	Johnson et al. D24/155	7,309,339	B2	12/2007	Cusick et al.
5,556,278	A	9/1996	Meitner	7,340,316	B2	3/2008	Spaeth et al.
5,569,261	A	10/1996	Marik et al.	7,359,746	B2	4/2008	Arata
5,601,563	A	2/1997	Burke et al.	7,393,012	B2	7/2008	Funakura et al.
5,662,656	A	9/1997	White	7,394,946	B2	7/2008	Dewaele
5,682,886	A	11/1997	Delp et al.	7,468,075	B2	12/2008	Lang et al.
5,683,398	A	11/1997	Caris et al.	7,547,307	B2	6/2009	Carson et al.
5,716,361	A	2/1998	Masini	7,611,519	B2	11/2009	Lefevre et al.
5,725,376	A	3/1998	Poirier	7,618,421	B2	11/2009	Axelson, Jr. et al.
5,749,876	A	5/1998	Duvillier et al.	7,618,451	B2	11/2009	Berez et al.
5,768,134	A	6/1998	Swaelens et al.	7,634,306	B2	12/2009	Sarin et al.
5,769,859	A	6/1998	Dorsey	7,641,660	B2	1/2010	Lakin et al.
D398,058	S *	9/1998	Collier D24/155	7,643,862	B2	1/2010	Schoenefeld
5,810,830	A	9/1998	Noble et al.	D618,796	S *	6/2010	Cantu et al. D24/140
5,824,100	A	10/1998	Kester et al.	D619,718	S *	7/2010	Gannoe et al. D24/155
5,824,111	A	10/1998	Schall et al.	D622,854	S *	8/2010	Otto et al. D24/155
5,860,980	A	1/1999	Axelson, Jr. et al.	D626,234	S *	10/2010	Otto et al. D24/155
5,860,981	A	1/1999	Bertin et al.	2002/0055783	A1	5/2002	Tallarida et al.
5,871,018	A	2/1999	Delp et al.	2002/0087274	A1	7/2002	Alexander et al.
5,880,976	A	3/1999	DiGioia III et al.	2002/0160337	A1	10/2002	Klein et al.
5,908,424	A	6/1999	Bertin et al.	2003/0009167	A1	1/2003	Wozencroft
5,964,808	A	10/1999	Blaha et al.	2003/0055502	A1	3/2003	Lang et al.
5,967,777	A	10/1999	Klein et al.	2003/0176783	A1	9/2003	Hu
5,993,448	A	11/1999	Remmler	2003/0216669	A1	11/2003	Lang et al.
6,002,859	A	12/1999	DiGioia, III et al.	2004/0097952	A1	5/2004	Sarin et al.
6,068,658	A	5/2000	Insall et al.	2004/0102792	A1	5/2004	Sarin et al.
6,090,114	A	7/2000	Matsuno et al.	2004/0102866	A1	5/2004	Harris et al.
6,096,043	A	8/2000	Techiera et al.	2004/0133276	A1	7/2004	Lang et al.
6,106,529	A	8/2000	Techiera	2004/0138754	A1	7/2004	Lang et al.
6,112,109	A	8/2000	D'Urso	2004/0147927	A1	7/2004	Tsougarakis et al.
6,132,447	A	10/2000	Dorsey	2004/0153066	A1	8/2004	Coon et al.
6,171,340	B1	1/2001	McDowell	2004/0153079	A1	8/2004	Tsougarakis et al.
6,205,411	B1	3/2001	DiGioia, III et al.	2004/0171924	A1	9/2004	Mire et al.
6,228,121	B1	5/2001	Khalili	2004/0204760	A1	10/2004	Fitz et al.
6,254,639	B1	7/2001	Peckitt	2004/0220583	A1	11/2004	Pieczynski, II et al.
6,343,987	B2	2/2002	Hayama et al.	2004/0236424	A1	11/2004	Berez et al.
6,382,975	B1	5/2002	Poirier	2004/0243148	A1	12/2004	Wasielewski
6,383,228	B1	5/2002	Schmotzer	2004/0254584	A1	12/2004	Sarin et al.
6,415,171	B1	7/2002	Gueziec et al.	2005/0059978	A1	3/2005	Sherry et al.
6,458,135	B1	10/2002	Harwin et al.	2005/0065617	A1	3/2005	Moctezuma de la Barrera
6,463,351	B1	10/2002	Clync	2005/0096535	A1	5/2005	de la Barrera
				2005/0113841	A1	5/2005	Sheldon et al.

2005/0119664	A1	6/2005	Carignan et al.	2009/0088763	A1	4/2009	Aram et al.
2005/0148843	A1	7/2005	Roose	2009/0093816	A1	4/2009	Roose et al.
2005/0148860	A1	7/2005	Liew et al.	2009/0110498	A1	4/2009	Park
2005/0192588	A1	9/2005	Garcia	2009/0112213	A1	4/2009	Heavener et al.
2005/0216024	A1	9/2005	Massoud	2009/0131941	A1	5/2009	Park et al.
2005/0234461	A1	10/2005	Burdulis, Jr. et al.	2009/0138020	A1	5/2009	Park et al.
2005/0245934	A1	11/2005	Tuke et al.	2009/0151736	A1	6/2009	Belcher et al.
2005/0245936	A1	11/2005	Tuke et al.	2009/0157083	A1	6/2009	Park et al.
2005/0256389	A1	11/2005	Koga et al.	2009/0222014	A1	9/2009	Bojarski et al.
2005/0267584	A1	12/2005	Burdulis, Jr. et al.	2009/0222015	A1	9/2009	Park et al.
2006/0015018	A1	1/2006	Jutras et al.	2009/0222016	A1	9/2009	Park et al.
2006/0015188	A1	1/2006	Grimes	2009/0248044	A1	10/2009	Amiot et al.
2006/0030853	A1	2/2006	Haines	2009/0254093	A1	10/2009	White et al.
2006/0036257	A1	2/2006	Steffensmeier	2009/0254367	A1	10/2009	Belcher et al.
2006/0110017	A1	5/2006	Tsai et al.	2009/0270868	A1	10/2009	Park et al.
2006/0111628	A1	5/2006	Tsai et al.	2009/0274350	A1	11/2009	Pavlovskaja et al.
2006/0122491	A1	6/2006	Murray et al.	2009/0306676	A1	12/2009	Lang et al.
2006/0155293	A1	7/2006	McGinley et al.	2009/0307893	A1	12/2009	Burdulis, Jr. et al.
2006/0155294	A1	7/2006	Steffensmeier et al.	2009/0312805	A1	12/2009	Lang et al.
2006/0195113	A1	8/2006	Masini	2010/0023015	A1	1/2010	Park
2006/0271058	A1	11/2006	Ashton et al.	2010/0042105	A1	2/2010	Park et al.
2006/0293681	A1	12/2006	Claypool et al.	2010/0049195	A1	2/2010	Park et al.
2007/0005073	A1	1/2007	Claypool et al.	2010/0152741	A1	6/2010	Park et al.
2007/0021838	A1	1/2007	Dugas et al.	2010/0298894	A1*	11/2010	Bojarski et al. 606/86 R
2007/0038059	A1	2/2007	Sheffer et al.				
2007/0055268	A1	3/2007	Utz et al.				
2007/0073305	A1	3/2007	Lionberger et al.				
2007/0100462	A1	5/2007	Lang et al.				
2007/0106389	A1	5/2007	Croxton et al.				
2007/0118055	A1	5/2007	McCombs				
2007/0118243	A1	5/2007	Schroeder et al.				
2007/0123912	A1	5/2007	Carson				
2007/0173858	A1	7/2007	Engh et al.				
2007/0191741	A1	8/2007	Tsai et al.				
2007/0198022	A1	8/2007	Lang et al.				
2007/0213738	A1	9/2007	Martin et al.				
2007/0219560	A1	9/2007	Hodorek				
2007/0226986	A1	10/2007	Chi et al.				
2007/0232959	A1	10/2007	Couture et al.				
2007/0233136	A1	10/2007	Wozencroft				
2007/0233140	A1	10/2007	Metzger et al.				
2007/0233141	A1	10/2007	Park et al.				
2007/0233269	A1	10/2007	Steines et al.				
2007/0239167	A1	10/2007	Pinczewski et al.				
2007/0249967	A1	10/2007	Buly et al.				
2007/0276224	A1	11/2007	Lang et al.				
2007/0276400	A1	11/2007	Moore et al.				
2007/0282451	A1	12/2007	Metzger et al.				
2007/0288030	A1	12/2007	Metzger et al.				
2008/0004701	A1	1/2008	Axelson et al.				
2008/0015433	A1	1/2008	Alexander et al.				
2008/0015599	A1	1/2008	D'Alessio et al.				
2008/0015600	A1	1/2008	D'Alessio et al.				
2008/0015602	A1	1/2008	Axelson et al.				
2008/0015606	A1	1/2008	Axelson et al.				
2008/0015607	A1	1/2008	Axelson et al.				
2008/0031412	A1	2/2008	Lang et al.				
2008/0033442	A1	2/2008	Amiot et al.				
2008/0088761	A1	4/2008	Lin et al.				
2008/0114370	A1	5/2008	Schoenefeld				
2008/0147072	A1	6/2008	Park et al.				
2008/0153067	A1	6/2008	Berckmans et al.				
2008/0161815	A1	7/2008	Schoenefeld et al.				
2008/0195108	A1	8/2008	Bhatnagar et al.				
2008/0215059	A1	9/2008	Carignan et al.				
2008/0234685	A1	9/2008	Gjerde				
2008/0243127	A1	10/2008	Lang et al.				
2008/0257363	A1	10/2008	Schoenefeld et al.				
2008/0262624	A1	10/2008	White et al.				
2008/0275452	A1	11/2008	Lang et al.				
2008/0281328	A1	11/2008	Lang et al.				
2008/0281329	A1	11/2008	Fitz et al.				
2008/0281426	A1	11/2008	Fitz et al.				
2008/0286722	A1	11/2008	Berckmans, III et al.				
2008/0287953	A1	11/2008	Sers				
2008/0287954	A1	11/2008	Kunz et al.				
2008/0312659	A1	12/2008	Metzger et al.				
2008/0319491	A1	12/2008	Schoenefeld				
2009/0024131	A1	1/2009	Metzger et al.				

FOREIGN PATENT DOCUMENTS			
DE	4341367	C1	6/1995
DE	10 2005 023	A1	11/2006
EP	0097001	A	12/1983
EP	0574098	A	12/1993
EP	0622052	A	11/1994
EP	0908836	A2	4/1999
EP	0908836	A3	12/1999
EP	1486900		12/2004
EP	1 532 939	A1	5/2005
GB	2215610		9/1989
GB	2420717	A	6/2006
WO	WO 93/25157		12/1993
WO	WO 95/07509	A1	3/1995
WO	WO 97/23172	A2	7/1997
WO	WO 98/12995	A2	4/1998
WO	WO 01/00096		1/2001
WO	WO 01/70142		9/2001
WO	WO 02/096268	A2	12/2002
WO	WO 2004/032806		4/2004
WO	WO 2004/049981		6/2004
WO	WO 2005/051240		6/2005
WO	2005/087125	A2	9/2005
WO	WO 2005/087125	A2	9/2005
WO	WO 2006/058057		6/2006
WO	WO 2006/060795		6/2006
WO	WO 2006/092600		9/2006
WO	WO 2006/134345	A1	12/2006
WO	WO 2007/014164		2/2007
WO	WO 2007/058632	A1	5/2007
WO	2007/092841	A2	8/2007
WO	WO 2007/092841	A2	8/2007

OTHER PUBLICATIONS	
Akenine-Möller et al., <i>Real-Time Rendering, Second Edition</i> , AK Peters, Natick, MA, 6 pages (Table of Contents), 2002.	
Author Unknown, "MRI Protocol Reference," ConforMIS, Inc., copyright 2007, http://www.conformis.com/Imaging-Professionals/MRI-Protocol-Guides , last visited on Mar. 28, 2008, 18 pages.	
Author Unknown, "MRI Protocol Reference Guide for GE Systems," ConforMIS, Inc., copyright 2007, http://www.conformis.com/Imaging-Professionals/MRI-Protocol-Guides , last visited on Mar. 28, 2008, 18 pages.	
Author Unknown, "MRI Protocol Reference Guide for Phillips Systems," ConforMIS, Inc., copyright 2007, http://www.conformis.com/Imaging-Professionals/MRI-Protocol-Guides , last visited on Mar. 28, 2008, 19 pages.	
Author Unknown, "MRI Protocol Reference Guide for Siemens Systems," ConforMIS, Inc., copyright 2007, http://www.conformis.com/Imaging-Professionals/MRI-Protocol-Guides , last visited on Mar. 28, 2008, 18 pages.	

- Barequet et al., "Filling Gaps in the Boundary of a Polyhedron," *Computer Aided Geometric Design*, vol. 12, pp. 207-229, 1995.
- Barequet et al., "Repairing CAD Models," Proceedings of the 8th IEEE Visualization '97 Conference, pp. 363-370, Oct. 1997.
- Berry et al., "Personalised image-based templates for intra-operative guidance," *Proc. Inst. Mech. Eng. Part H: J. Engineering in Medicine*, vol. 219, pp. 111-118, Oct. 7, 2004.
- Bišćević et al., "Variations of Femoral Condyle Shape," *Coll. Antropol.*, vol. 29 No. 2, pp. 409-414, 2005.
- Blinn, Jim Blinn's Corner—*A Trip Down the Graphics Pipeline*, Morgan Kaufmann Publishers, Inc., San Francisco, CA, 5 pages (Table of Contents), 1996.
- Bøhn et al., "A Topology-Based Approach for Shell-Closure," *Geometric Modeling for Product Realization* (P.R. Wilson et al. editors), pp. 297-319, Elsevier Science Publishers B.V., North-Holland, 1993.
- Chauhan et al., "Computer-assisted knee arthroplasty versus a conventional jig-based technique—a randomised, prospective trial," *The Journal of Bone and Joint Surgery*, vol. 86-B, No. 3, pp. 372-377, Apr. 2004.
- Cohen et al., *Radiosity and Realistic Image Synthesis*, Academic Press Professional, Cambridge, MA, 8 pages (Table of Contents), 1993.
- Couglin et al., "Tibial Axis and Patellar Position Relative to the Femoral Epicondylar Axis During Squatting," *The Journal of Arthroplasty*, vol. 18, No. 8, Elsevier, 2003.
- Delp et al., "Computer Assisted Knee Replacement," *Clinical Orthopaedics and Related Research*, No. 354, pp. 49-56, Sep. 1998.
- Dutr e et al., *Advanced Global Illumination*, AK Peters, Natick, MA, 5 pages (Table of Contents), 2003.
- Eckhoff et al., "Three-Dimensional Mechanics, Kinematics, and Morphology of the Knee Viewed in Virtual Reality," *The Journal of Bone and Joint Surgery*, vol. 87-A, Supplement 2, pp. 71-80, 2005.
- Erikson, "Error Correction of a Large Architectural Model: The Henderson County Courthouse," Technical Report TR95-013, Dept. of Computer Science, University of North Carolina at Chapel Hill, pp. 1-11, 1995.
- Ervin et al., *Landscape Modeling*, McGraw-Hill, New York, NY, 8 pages (Table of Contents), 2001.
- Farin, *NURB Curves and Surfaces: From Projective Geometry to Practical Use*, AK Peters, Wellesley, MA, 7 pages (Table of Contents), 1995.
- Fleischer et al., "Accurate Polygon Scan Conversion Using Half-Open Intervals," *Graphics Gems III*, pp. 362-365, code: pp. 599-605, 1992.
- Foley et al., *Computer Graphics: Principles and Practice*, Addison-Wesley Publishing Company, Reading, MA, 9 pages (Table of Contents), 1990.
- Glassner (editor), *An Introduction to Ray Tracing*, Academic Press Limited, San Diego, CA, 4 pages (Table of Contents), 1989.
- Glassner, *Principles of Digital Image Synthesis*, Volumes One and Two, Morgan Kaufmann Publishers, Inc., San Francisco, CA, 32 pages (Table of Contents), 1995.
- Gooch et al., *Non-Photorealistic Rendering*, AK Peters, Natick, MA, 4 pages (Table of Contents), 2001.
- Gr une et al., "On numerical algorithm and interactive visualization for optimal control problems," *Journal of Computation and Visualization in Science*, vol. 1, No. 4, pp. 221-229, Jul. 1999.
- Gu eziec et al., "Converting Sets of Polygons to Manifold Surfaces by Cutting and Stitching," *Proc. IEEE Visualization 1998*, pp. 383-390, Oct. 1998.
- Hafez et al., "Patient Specific Instrumentation for TKA: Testing the Reliability Using a Navigational System," MIS Meets CAOS Symposium & Instructional Academy, Less and Minimally Invasive Surgery for Joint Arthroplasty: Fact and Fiction Syllabus, San Diego, CA, 8 pages, Oct. 20-22, 2005.
- Hafez et al., "Computer Assisted Total Knee Replacement: Could a Two-Piece Custom Template Replace the Complex Conventional Instrumentations?," *Computer Aided Surgery*, vol. 9, No. 3, pp. 93-94, 2004.
- Hafez et al., "Computer-Assisted Total Knee Arthroplasty Using Patient-Specific Templating," *Clinical Orthopaedics and Related Research*, No. 0, pp. 1-9, 2006.
- Jensen, *Realistic Image Synthesis Using Photon Mapping*, AK Peters, Natick, MA, 7 pages (Table of Contents), 2001.
- Jones et al., "A new approach to the construction of surfaces from contour data," *Computer Graphics Forum*, vol. 13, No. 3, pp. 75-84, 1994 [ISSN 0167-7055].
- Khorramabadi, "A Walk Through the Planned CS Building," Technical Report UCB/CSD91/652, Computer Science Department, University of California at Berkeley, 74 pages, 1991.
- Kidder et al., "3-D Model Acquisition, Design, Planning and Manufacturing of Orthopaedic Devices: A Framework," *Advanced Sensor and Control-System Interface* (B.O. Nnaji editor), Proceedings SPIE—The International Society for Optical Engineering, Bellingham, WA, vol. 2911, pp. 9-22, Nov. 21-22, 1996.
- Kumar, *Robust Incremental Polygon Triangulation for Surface Rendering*, Center for Geometric Computing, Department of Computer Science, Johns Hopkins University, Baltimore, MD, WSCG, The International Conference in Central Europe on Computer Graphics, Visualization and Computer Vision, pp. 381-388, 2000.
- Lorensen et al., "Marching Cubes: A High Resolution 3d Surface Construction Algorithm," *Computer Graphics*, vol. 21, No. 4, pp. 163-169, 1987.
- Morvan et al., IVECS, Interactively Correcting .STL Files in a Virtual Environment, Clemson University, Clemson, SC, Proc. Conf. Virtual Design, Aug. 1996.
- Nooruddin et al., Simplification and Repair of Polygonal Models Using Volumetric Techniques, *IEEE Transactions on Visualization and Computer Graphics*, vol. 9, No. 2, pp. 191-205, Apr.-Jun. 2003.
- Pharr et al., *Physically Based Rendering, from Theory to Implementation*, Morgan Kaufmann Publishers, San Francisco, CA, 13 pages (Table of Contents), 2004.
- Platt et al., "Mould Arthroplasty of the Knee, A Ten-Year Follow-up Study," *The Journal of Bone and Joint Surgery* (British Volume), vol. 51-B, No. 1, pp. 76-87, Feb. 1969.
- Potter, "Arthroplasty of the Knee with Tibial Metallic Implants of the McKeever and MacIntosh Design," *The Surgical Clinics of North America*, vol. 49, No. 4, pp. 903-915, Aug. 1969.
- Radermacher et al., "Computer Assisted Orthopaedic Surgery with Image Based Individual Templates," *Clinical Orthopaedics and Related Research*, vol. 354, pp. 28-38, Sep. 1998.
- Rohlfing et al., "Quo Vadis, Atlas-Based Segmentation?," *The Handbook of Medical Image Analysis: Segmentation and Registration Models* (Kluwer), pp. 1-55, (http://www.stanford.edu/~rohrfing/publications/2005-rohlfing-chapter-quo_vadis_atlas_based_segmentation.pdf).
- Shirley et al., *Realistic Ray Tracing, Second Edition*, AK Peters, Natick, MA, 7 pages (Table of Contents), 2003.
- Strothotte et al., *Non-Photorealistic Computer Graphics—Modeling, Rendering, and Animation*, Morgan Kaufmann Publishers, San Francisco, CA, 9 pages (Table of Contents), 2002.
- Vande Berg et al., "Assessment of Knee Cartilage in Cadavers with Dual-Detector Spiral CT Arthrography and MR Imaging," *Radiology*, vol. 222, No. 2, pp. 430-436, Feb. 2002.
- Wikipedia, the Free Encyclopedia, "CNC," (date unknown) located at <http://en.wikipedia.org/wiki/CNC>, 6 pages, last visited on Apr. 12, 2007.
- Office Action, U.S. Appl. No. 10/146,862, mailed Jan. 13, 2005, 10 pages.
- Amendment and Response to Office Action and Petition to Revoke, U.S. Appl. No. 10/146,862, filed Jan. 18, 2006, 29 pages.
- International Search Report and Written Opinion, PCT/US2007/001624, dated Dec. 12, 2007, 14 pages.
- Invitation to Pay Additional Fees mailed on Jul. 31, 2007, for PCT Application No. PCT/US2007/001624 filed on Jan. 19, 2007, 5 pages.
- International Search Report and Written Opinion, PCT/US2007/001622, dated Jun. 11, 2007, 14 pages.
- Restriction Requirement, U.S. Appl. No. 11/641,569, mailed Apr. 27, 2009, 7 pages.
- International Search Report and Written Opinion, International Application No. PCT/US2009/34983, mailed May 22, 2009, 15 pages.

- International Search Report and Written Opinion, International Application No. PCT/US2009/034967, mailed Jun. 16, 2009, 15 pages.
- International Search Report and Written Opinion, International Application No. PCT/US2009/041519, mailed Jun. 17, 2009, 10 pages.
- Kunz et al., "Computer Assisted Hip Resurfacing Using Individualized Drill Templates," *The Journal of Arthroplasty*, vol. 00, No. 0, pp. 1-7, 2009.
- Amendment and Response to Non-Final Office Action, U.S. Appl. No. 11/641,382, dated Apr. 20, 2010, 23 pages.
- Amendment and Response to Office Action, U.S. Appl. No. 11/656,323, filed Jun. 25, 2010, 7 pages.
- Amendment and Response to Restriction Requirement, U.S. Appl. No. 11/641,382, dated Oct. 5, 2009, 10 pages.
- Amendment and Response to Restriction Requirement, U.S. Appl. No. 11/642,385, filed Nov. 24, 2009, 10 pages.
- Amendment and Response to Restriction/Election Requirement, U.S. Appl. No. 11/656,323, filed Dec. 8, 2009, 6 pages.
- Amendment and Response, U.S. Appl. No. 11/642,385, filed May 28, 2010, 11 pages.
- Amendment and Response to Restriction Requirement, U.S. Appl. No. 11/641,569, dated May 27, 2009, 12 pages.
- Amendment and Response to Office Action, U.S. Appl. No. 11/641,569, dated Feb. 5, 2010, 20 pages.
- Amendment and Response to Final Office Action, U.S. Appl. No. 11/642,385, filed Oct. 4, 2010, 16 pages.
- Final Office Action and PTO-892, U.S. Appl. No. 11/641,382, mailed Aug. 5, 2010, 13 pages.
- Final Office Action and PTO-892, U.S. Appl. No. 11/642,385, mailed Aug. 5, 2010, 10 pages.*
- Final Office Action and PTO-892, U.S. Appl. No. 11/656,323, mailed Sep. 3, 2010, 11 pages.*
- Final Office Action, U.S. Appl. No. 11/641,569, mailed May 10, 2010, 9 pages.*
- International Preliminary Report on Patentability, PCT/US2009/034983, dated Sep. 10, 2010, 13 pages.*
- International Search Report and Written Opinion, International Application No. PCT/US2009/058946, mailed Jan. 28, 2010, 14 pages.*
- International Search Report and Written Opinion, International Application No. PCT/US2009/068055, mailed Mar. 11, 2010, 10 pages.*
- Non-Final Office Action and PTO-892, U.S. Appl. No. 11/641,382, mailed Jan. 20, 2010, 12 pages.*
- Non-Final Office Action and PTO-892, U.S. Appl. No. 11/642,385, mailed Mar. 2, 2010, 11 pages.*
- Non-Final Office Action and PTO-892, U.S. Appl. No. 11/656,323, mailed Mar. 30, 2010, 10 pages.*
- Notice of Non-Compliant Amendment, U.S. Appl. No. 11/641,569, mailed Aug. 7, 2009, 3 pages.*
- Preliminary Amendment, U.S. Appl. No. 11/641,569, dated Aug. 14, 2008, 13 pages.*
- Preliminary Amendment, U.S. Appl. No. 11/642,385, filed Aug. 22, 2008, 42 pages.*
- RCE/Amendment, U.S. Appl. No. 11/641,569, filed Aug. 9, 2010.*
- Response to Notice of Non-Compliant Amendment, U.S. Appl. No. 11/641,569, dated Aug. 19, 2009, 11 pages.*
- AKCA, "Matching of 3D Surfaces and Their Intensities," *ISPRS Journal of Photogrammetry & Remote Sensing*, 62(2007), 112-121.*
- Arima et al., "Femoral Rotational Alignment, Based on the Anteroposterior Axis, in Total Knee Arthroplasty in a Valgus Knee. A Technical Note," *Journal Bone Joint Surg Am*. 1995;77(9):1331-4.*
- Bargar et al., "Robotic Systems in Surgery," *Orthopedic and Spine Surgery, Surgical Technology International II*, 1993, 419-423.*
- Besl et al., "A Method for Registration of 3-D Shapes," *IEEE Transactions on Pattern Analysis and Machine Intelligence (PAMI)*, 14(2):239-256, Feb. 1992.*
- Blaha et al., "Using the Transepicondylar Axis to Define the Sagittal Morphology of the Distal Part of the Femur," *J Bone Joint Surg Am*. 2002;84-A Suppl 2:48-55.*
- Bullough et al., "The Geometry of Diarthrodial Joints, Its Physiologic Maintenance and the Possible significance of Age-Related Changes in Geometry-to-Load distribution and the Development of Osteoarthritis," *Clin Orthop Rel Res* 1981, 156:61-6.*
- Burgkart et al., "Magnetic Resonance Imaging-Based Assessment of Cartilage Loss in Severe Osteoarthritis: Accuracy, Precision, and Diagnostic Value," *Arthritis Rheum* 2001, 44:2072-7.*
- Canny, "A computational Approach to Edge Detection," *IEEE Transactions on Pattern Analysis and Machine Intelligence, PAMI* 8(6), pp. 679-698 (1986).*
- Churchill et al., "The Transepicondylar Axis Approximates the Optimal Flexion Axis of the Knee," *Clin Orthop Relat Res*. 1998(356):111-8.*
- Cicuttini et al., "Gender Differences in Knee Cartilage Volume as Measured by Magnetic Resonance Imaging," *Osteoarthritis Cartilage* 1999, 7:265-71.
- Cicuttini et al., "Longitudinal Study of the Relationship Between Knee angle and Tibiofemoral cartilage Volume In Subjects with Knee Osteoarthritis," *Rheumatology (Oxford)* 2004, 43:321-4.
- Eckhoff et al., "Difference Between the Epicondylar and Cylindrical Axis of the Knee," *Clin Orthop Relat Res*. 2007;461:238-44.
- Eisenhart-Rothe et al., "Femorotibial and Patellar Cartilage Loss in Patients Prior to Total Knee arthroplasty, Heterogeneity, and Correlation with alignment of the Knee," *Ann Rheum Dis*, Jun. 2005 (BMJ Publishing Group Ltd & European League Against Rheumatism).
- Eisenhart-Rothe et al., "The Role of Knee alignment in Disease Progression and Functional Decline in Knee Osteoarthritis," *JAMA* 2001, 286:188-95.
- Elias et al., "A Correlative Study of the Geometry and anatomy of the Distal Femur," *Clinical Orthopaedics and Related Research* 1990(260):98-103.
- Favorito et al., "total Knee Arthroplasty in the Valgus Knee," *Journal Am Acad Orthop surg*. 2002;10(1):16-24.
- Freeman et al., "The Movement of the Knee Studied by Magnetic Resonance Imaging," *Clinical Orthopaedics and Related Research* 2003(410):35-43.
- Freeman et al., "The Movement of the Normal Tibio-Femoral Joint," *Journal Biomech*. 2005;38(2):197-208.
- Graichen et al., "Quantitative Assessment of Cartilage Status in Osteoarthritis by Quantitative Magnetic Resonance Imaging: Technical Validation for Use in analysis of Cartilage Volume And Further Morphologic Parameters," *Arthritis Rheum* 2004, 50:811-16.
- Gruen et al., "Least Squares 3D Surface and Curve Matching," *ISPRS Journal of Photogrammetry & Remote Sensing*, 59(2005), 151-174.
- Hollister et al., "The Axes of Rotation of the Knee," *Clinical Orthopaedics and Related Research* 1993(290):259-68.
- Howell et al., "Longitudinal Shapes of the Tibia and Femur are Unrelated and Variable," *Clinical Orthopaedics and Related Research* (2010) 468: 1142-1148.
- Howell et al., "Results of an Initial Experience with Custom-Fit Positioning Total Knee Arthroplasty in a Series of 48 Patients," *Orthopedics*, 2008;31(9):857-63.
- Howell et al., "In Vivo Adduction and Reverse Axial Rotation (External) of the Tibial Component can be Minimized During Standing and Kneeling," *Orthopedics*, In Press.
- Iwaki et al., "Tibiofemoral Movement 1: The Shapes and Relative Movements of the Femur and Tibia in the Unloaded Cadaver Knee," *Journal Bone Joint Surg Br*. 2000;82(8):1189-95.
- Jacobs et al., "Hip Resurfacing Through an Anterolateral Approach," *J. Bone Joint Surg Am*. 2008;90 Suppl 3:38-44.
- Johnson, "Joint Remodeling as the Basis for Osteoarthritis," *Journal Am Vet Med Assoc*. 1962, 141:1233-41.
- Kass et al., "Active Contour Models, *International Journal of Computer Vision*," pp. 321-331 (1988).
- Kellgren et al., "Radiological Assessment of Osteoarthrosis," *Ann Rheum Dis* 1957, 10:494-501.
- Kessler et al., "Sagittal Curvature of Total Knee Replacements Predicts in vivo Kinematics," *Clin Biomech (Bristol, Avon)* 2007; 22(1):52-8.
- Kienzel III et al., "Total Knee Replacement," *IEEE May/June*. 1995.
- Kienzel III et al., "An Integrated CAD-Robotics System for Total Knee Replacement Surgery", *IEEE International Conference*, pp. 889-894, vol. 1, May 1993.

- Krackow et al., "Flexion-Extension Joint Gap Changes After Lateral Structure Release for Valgus Deformity Correction in Total Knee Arthroplasty: A Cadaveric Study," *Journal Arthroplasty*, 1999;14(8):994-1004.
- Krackow et al., "Primary Total Knee Arthroplasty in Patients with Fixed Valgus Deformity," *Clin Orthop Relat Res*. 1991(273):9-18.
- Krackow, "Approaches to Planning lower Extremity alignment for Total Knee arthroplasty and Osteotomy About the Knee," *adv Orthop surg* 7:69, 1983.
- Lea et al., "Registration and immobilization in robot-assisted surgery", *Journal of Image Guided Surgery*, pp. 1-10, 1995.
- Manner et al., "Knee Deformity in Congenital Longitudinal Deficiencies of the Lower Extremity," *Clin Orthop Relat Res*. 2006;448:185-92.
- Matsuda et al., "Anatomical Analysis of the Femoral Condyle in Normal and Osteoarthritic Knees," *Journal Orthopaedic Res*. 2004;22(1):104-9.
- Matsuda et al., "Femoral Condyle Geometry in the Normal and Varus Knee," *Clinical Orthop Relat Res*. 1998(349):183-8.
- Messmer et al., "Volumetric Model Determination of the Tibia Based on 2d Radiographs Using A 2d/3d Database", Dept. Of Surgery, Trauma Unit, University Hospital, Basel, Switzerland, *Computer Aided Surgery* 6:183-194 (2001).
- Mihalko et al., "The Variability of Intramedullary Alignment of the Femoral Component During Total Knee Arthroplasty," *Journal Arthroplasty*. 2005;20(1):25-8.
- Morvan et al., IVECS, Interactively Correcting .STL Files in a Virtual Environment, Clemson University, Clemson, SC, Proc. Conf. Virtual Design, Aug. 1996.
- Kusumoto, Taiji et al., "Application of Virtual Reality Force Feedback Haptic Device for Oral Implant Surgery", Graduate School of Dentistry Course for Integrated Oral Science and Stomatology, Jun. 16, 2005.
- Panjabi et al., "Errors in Kinematic Parameters of a Planar Joint: Guidelines for Optimal Experimental Design," *Journal Biomech*. 1982;15(7):537-44.
- Perillo-Marcone et al., "Effect of Varus/Valgus Malalignment on Bone Strains in the Proximal Tibia After TKR: An Explicit Finite element Study," *Journal Biomechanical Engineering* 2007, vol. 129, 1:1-11.
- Peterfy et al., "Quantification of articular Cartilage in the Knee with Pulsed Saturation Transfer Subtraction and Fact-Suppressed MR Imaging: Optimization and Validation," *Radiology* 1994, 192:485-91.
- Pinskerova et al., "The Shapes and Relative Movements of the Femur and Tibia at the Knee," *Orthopaedics* 2000;29 Suppl 1:S3-5.
- Rosset et al., "General Consumer Communication Tools for Improved Image Management and Communication in Medicine," *Journal Digital Imaging*, 2005;18(4):270-9.
- Shakespeare D., "Conventional Instruments in Total Knee Replacement: What Should We Do With Them?" *Knee*. 2006;13(1):1-6.
- Shepstone et al., "The shape of the Distal Femur: a Palaeopathological Comparison of Eburnated and Non-Eburnated Femora," *Ann. Rheum Dis*. 1999, 58:72-8.
- Siston et al., "The Variability of Femoral Rotational Alignment in Total Knee Arthroplasty," *Journal Bone Joint Surg Am*. 2005;87(10):2276-80.
- Siston et al., "Averaging Different Alignment Axes Improves Femoral Rotational Alignment in Computer-Navigated Total Knee Arthroplasty," *Journal Bone Joint Surg Am*. 2008;90(10):2098-104.
- Soudan et al., "Methods, Difficulties and Inaccuracies in the Study of Human Joint Kinematics and Pathokinematics by the Instant axis Concept. Example: The Knee Joint," *Journal Biomech*. 1979;12(1):27-33.
- Spencer et al., "Initial Experience with Custom-Fit Total Knee Replacement: Intra-operative Events and Long-Leg Coronal alignment," *International Orthopaedics (SICOT)*, 2009:In Press.
- Stulberg et al., "Computer- and Robot-Assisted Orthopaedic Surgery", *Computer-Integrated Surgery Technology and Clinical Applications*, edited by Taylor et al., Massachusetts Institute of Technology, Chapter 27, pp. 373-378, 1996.
- Teeny et al., "Primary Total Knee Arthroplasty in Patients with Severe Varus Deformity. A Comparative Study," *Clin Orthop Relat Res*. 1991(273):19-31.
- Wright Medical Technology, Inc., "Prophecy Pre-Operative Navigation Guides Surgical Technique," 2009.
- International Search Report and Written Opinion, International Application No. PCT/US2009/040629, mailed Aug. 6, 2009, 9 pages.
- Restriction Requirement, U.S. Appl. No. 11/641,382, mailed Sep. 3, 2009, 6 pages.
- Restriction Requirement, U.S. Appl. No. 11/642,385, mailed Oct. 27, 2009, 7 pages.
- International Search Report and Written Opinion, International Application No. PCT/US2009/051109, mailed Nov. 6, 2009, 13 pages.
- NonFinal Office Action, U.S. Appl. No. 11/641,569, mailed Nov. 12, 2009, 9 pages.
- Restriction Requirement, U.S. Appl. No. 11/656,323, mailed Nov. 13, 2009, 10 pages.
- Advisory Action, U.S. Appl. No. 11/642,385, filed Oct. 29, 2010.
- Request for Continued Examination/Amendment, U.S. Appl. No. 11/642,385, filed Dec. 6, 2010.
- Request for Continued Examination/Amendment, U.S. Appl. No. 11/656,323, filed Nov. 19, 2010.
- Response to Restriction Requirement, U.S. Appl. No. 11/959,344, filed Nov. 24, 2010.
- International Preliminary Report on Patentability, PCT/US2009/040629, dated Nov. 11, 2010.
- International Preliminary Report on Patentability, PCT/US2009/041519, dated Nov. 11, 2010.
- International Preliminary Report on Patentability, PCT/US2008/083125, dated Jul. 1, 2010.
- International Preliminary Report on Patentability, PCT/US2007/001624, dated Aug. 19, 2008.
- International Preliminary Report on Patentability/PCT/US2007/001622, dated Dec. 28, 2009.
- International Preliminary Report on Patentability, PCT/US2009/034967, dated Nov. 11, 2010.
- International Preliminary Report on Patentability, PCT/US2009/034983, dated Sep. 10, 2010.
- International Preliminary Report on Patentability, PCT/US2009/051109, dated Jan. 25, 2011.
- Restriction Requirement, U.S. Appl. No. 11/959,344, dated Oct. 29, 2010.
- European Search Report, Application No. 10192631.9-2310, dated Mar. 17, 2011, 5 pages.

* cited by examiner

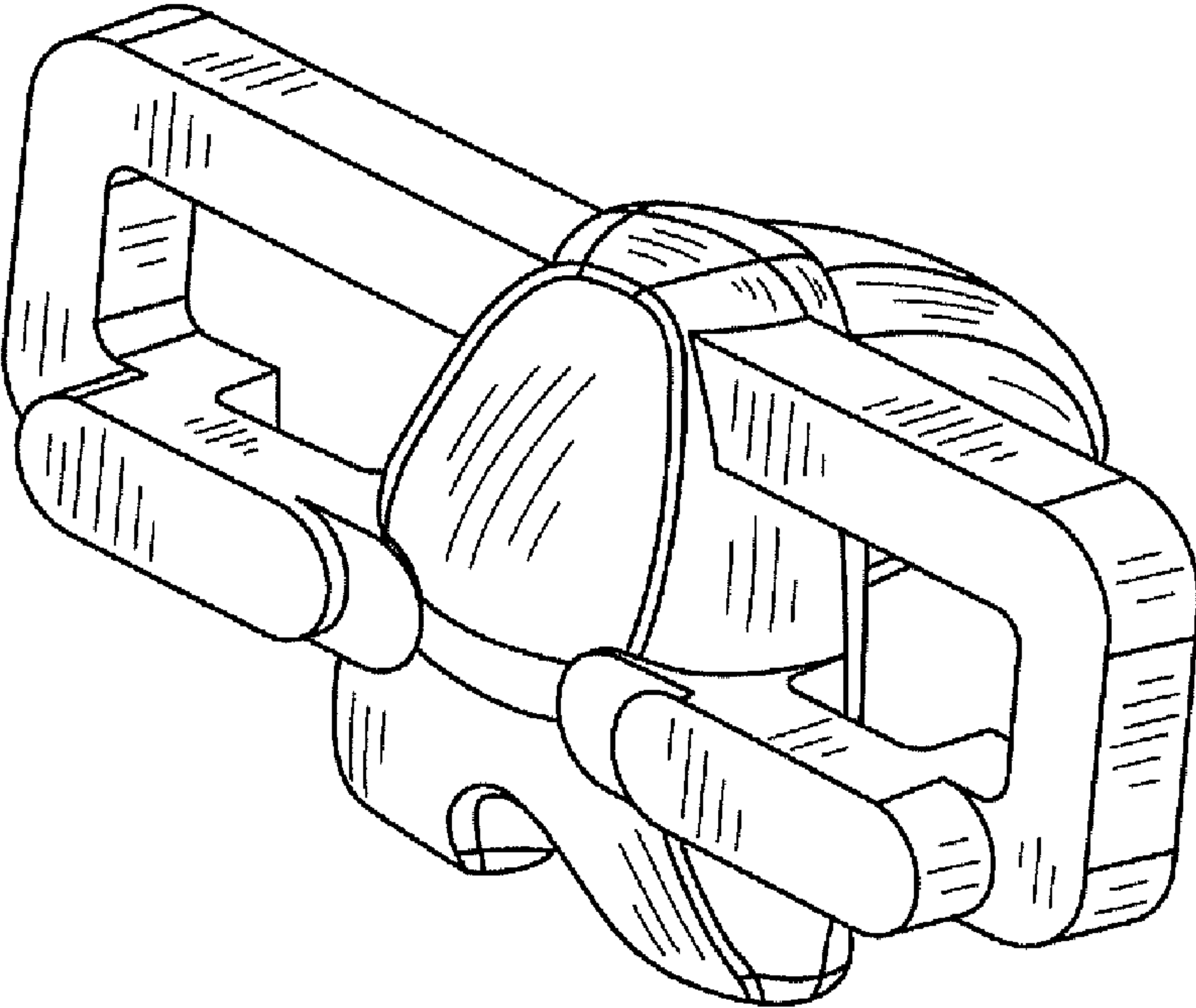

FIG. 1

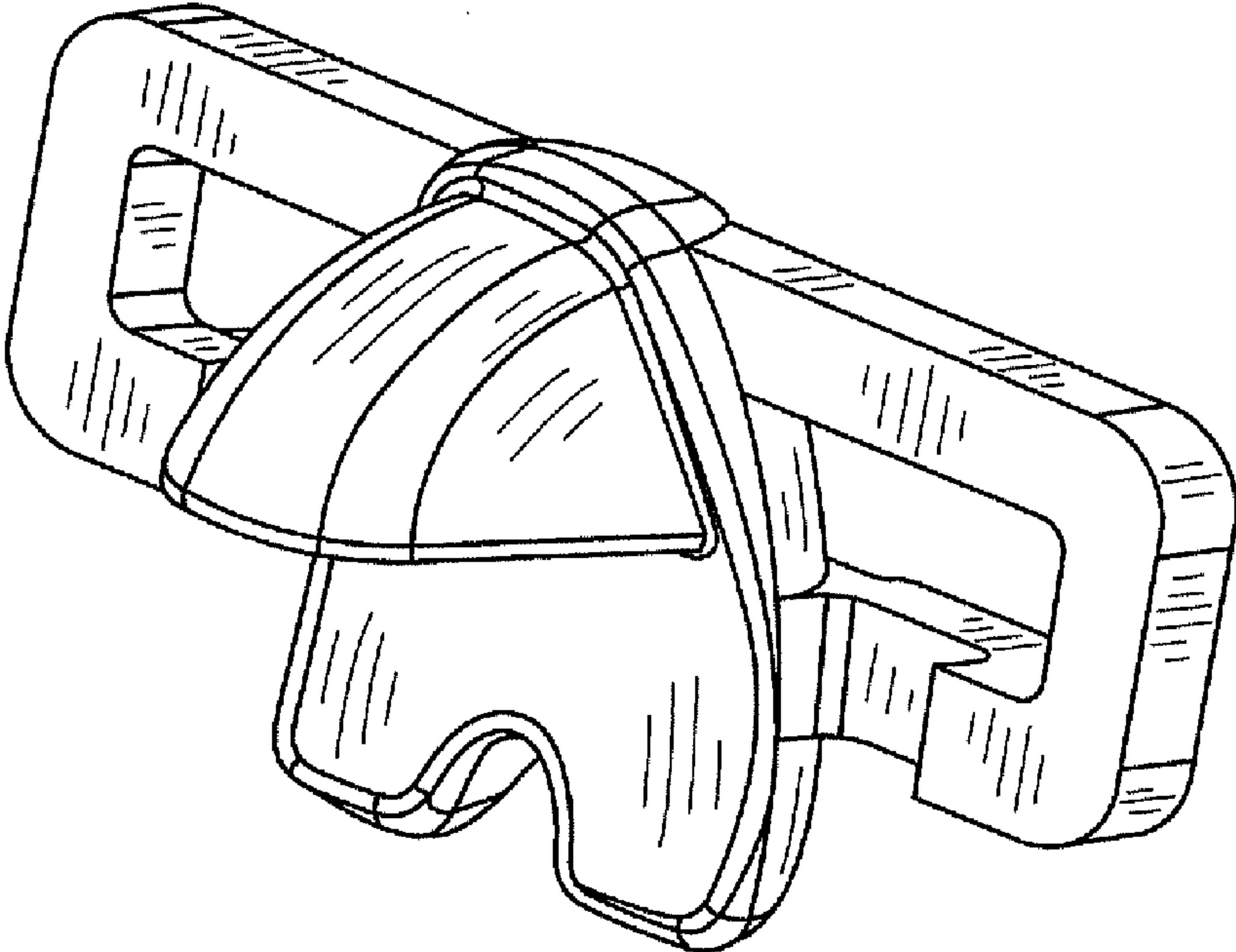

FIG. 2

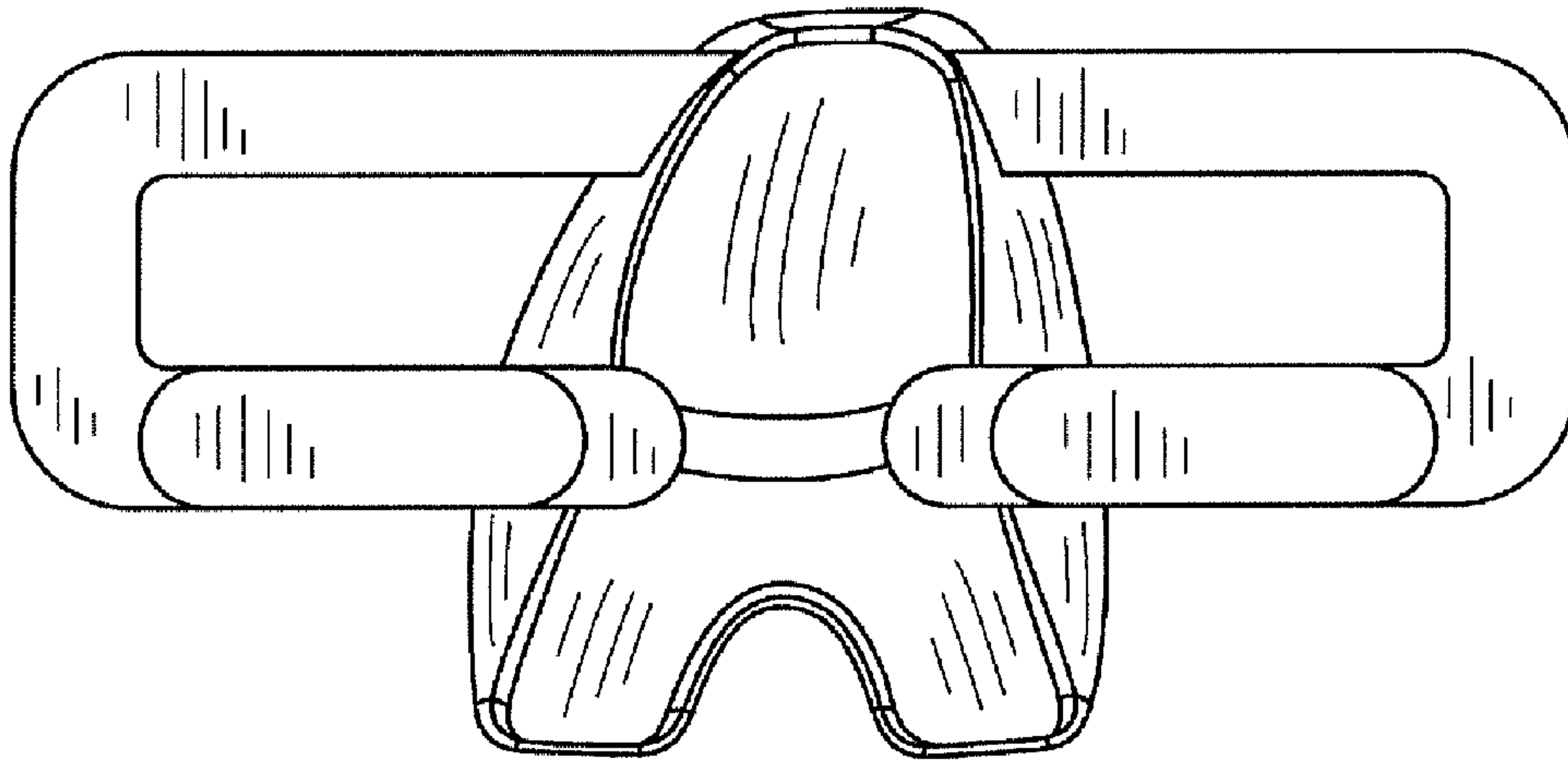

FIG. 3

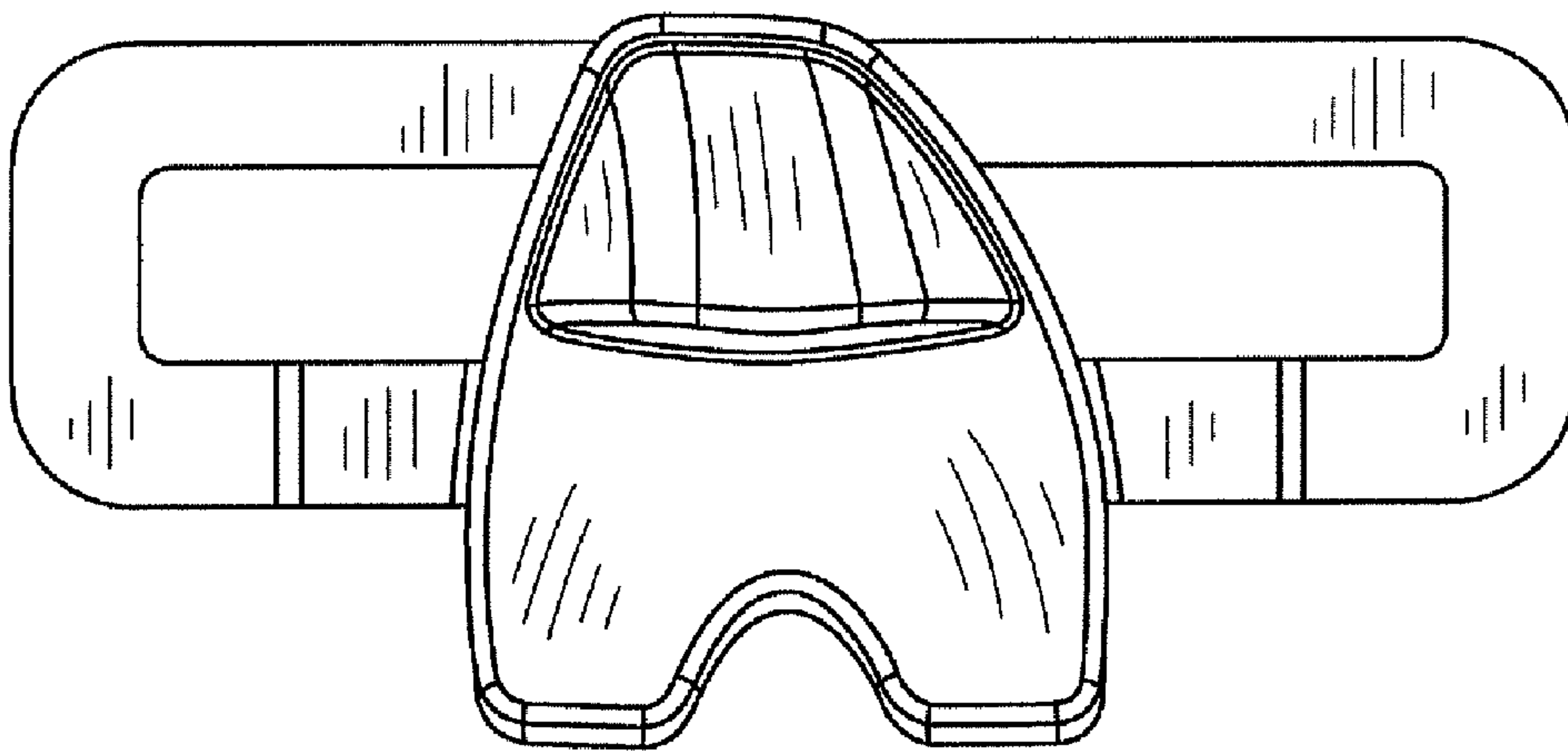

FIG. 4

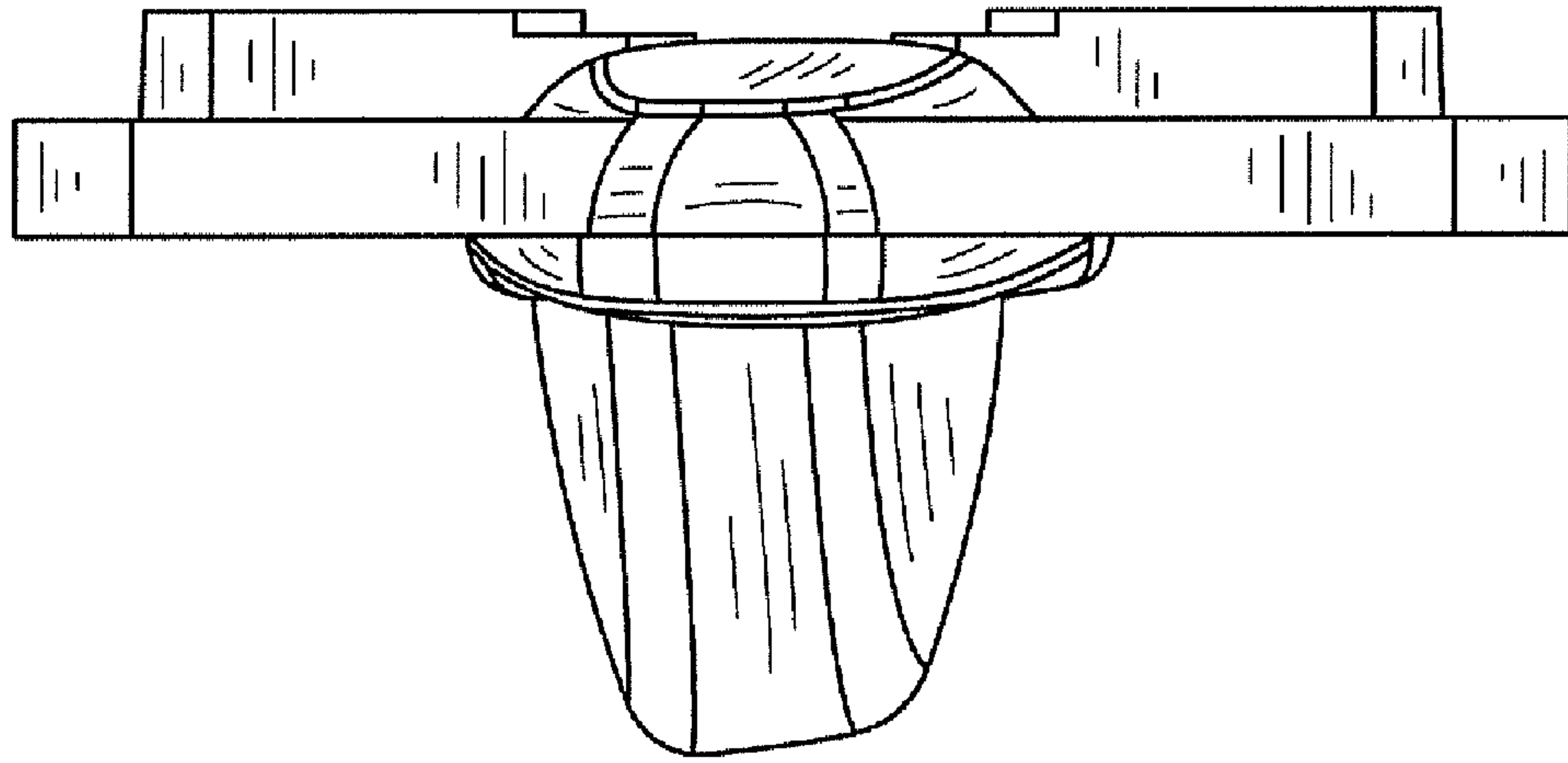

FIG. 5

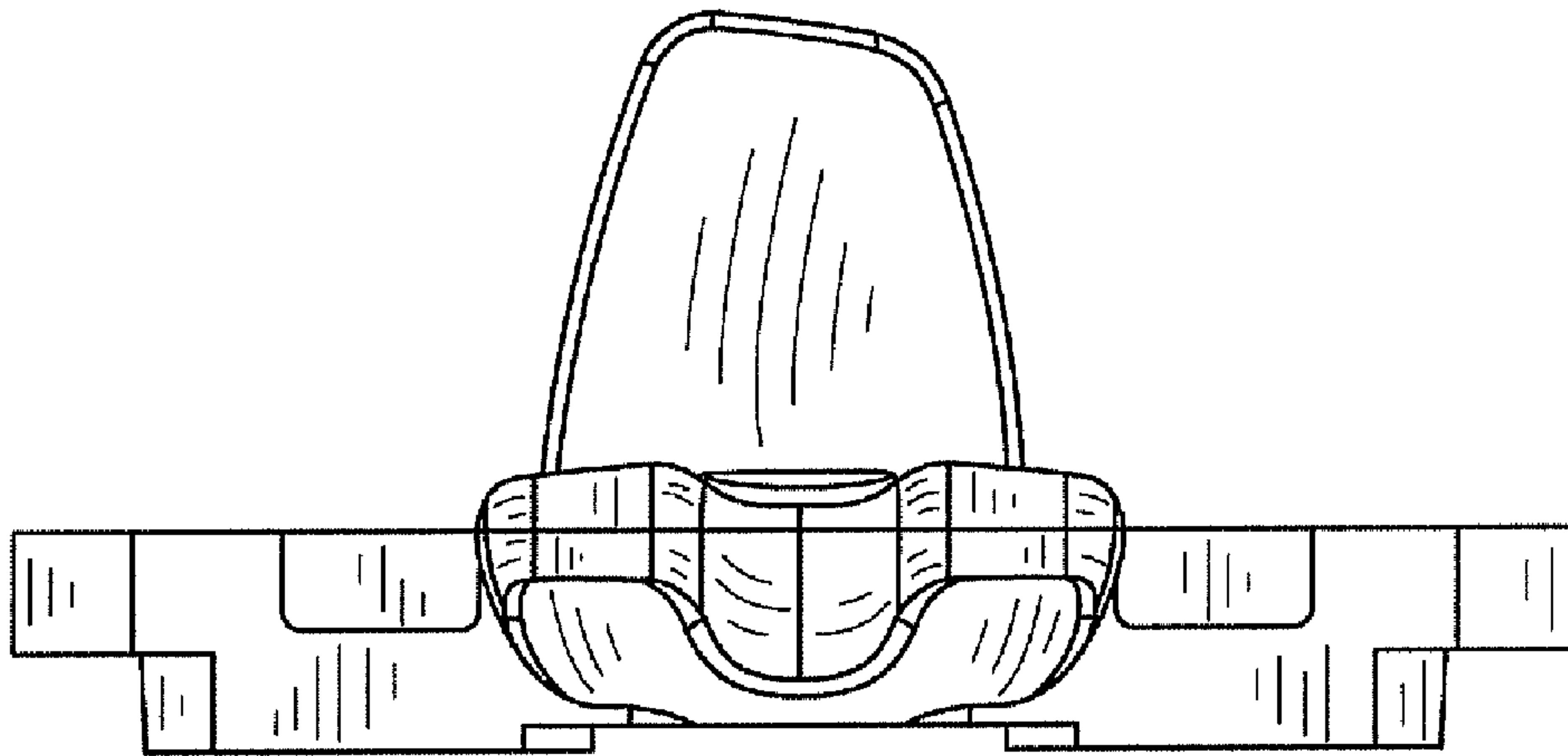

FIG. 6

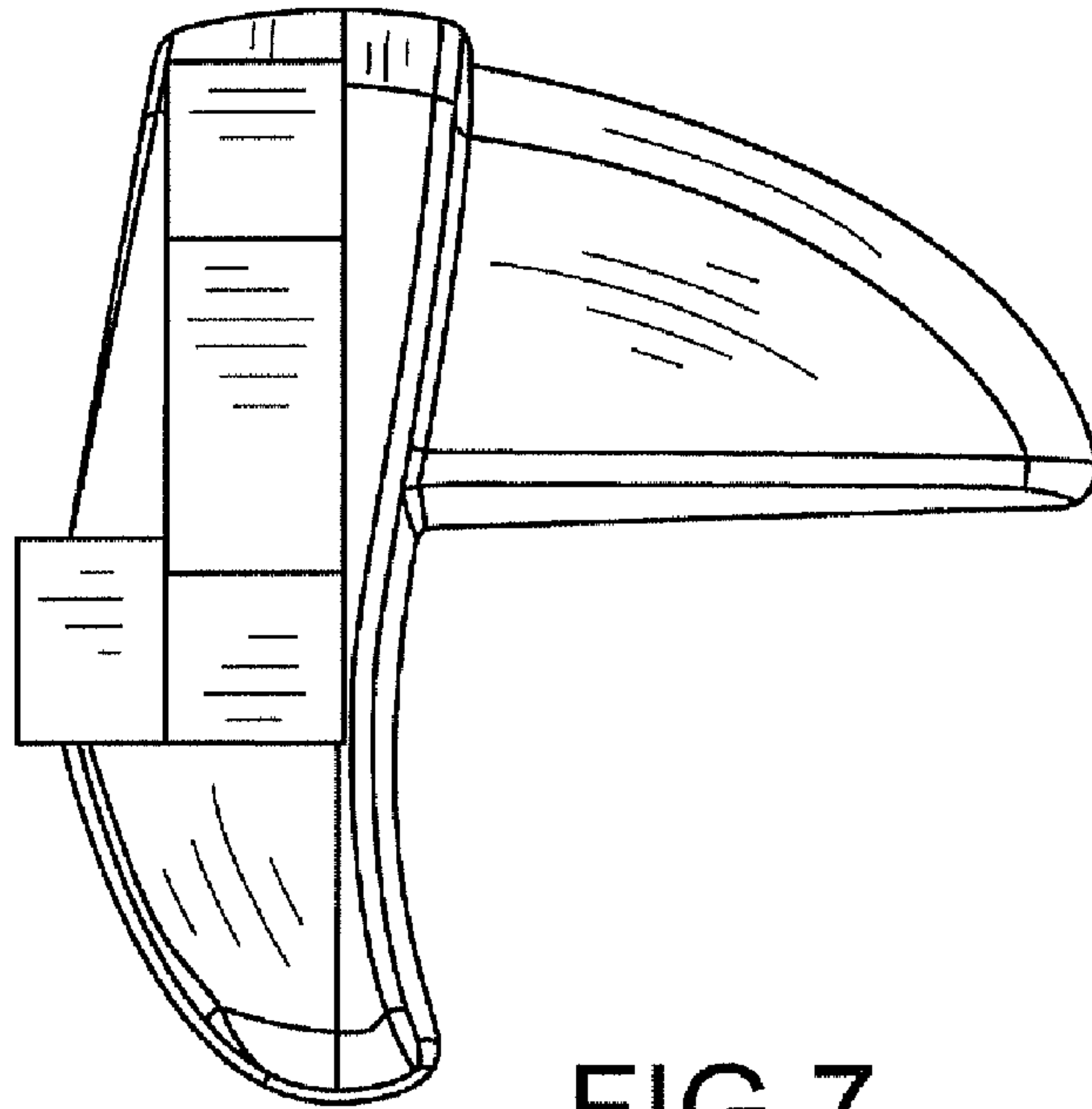

FIG. 7

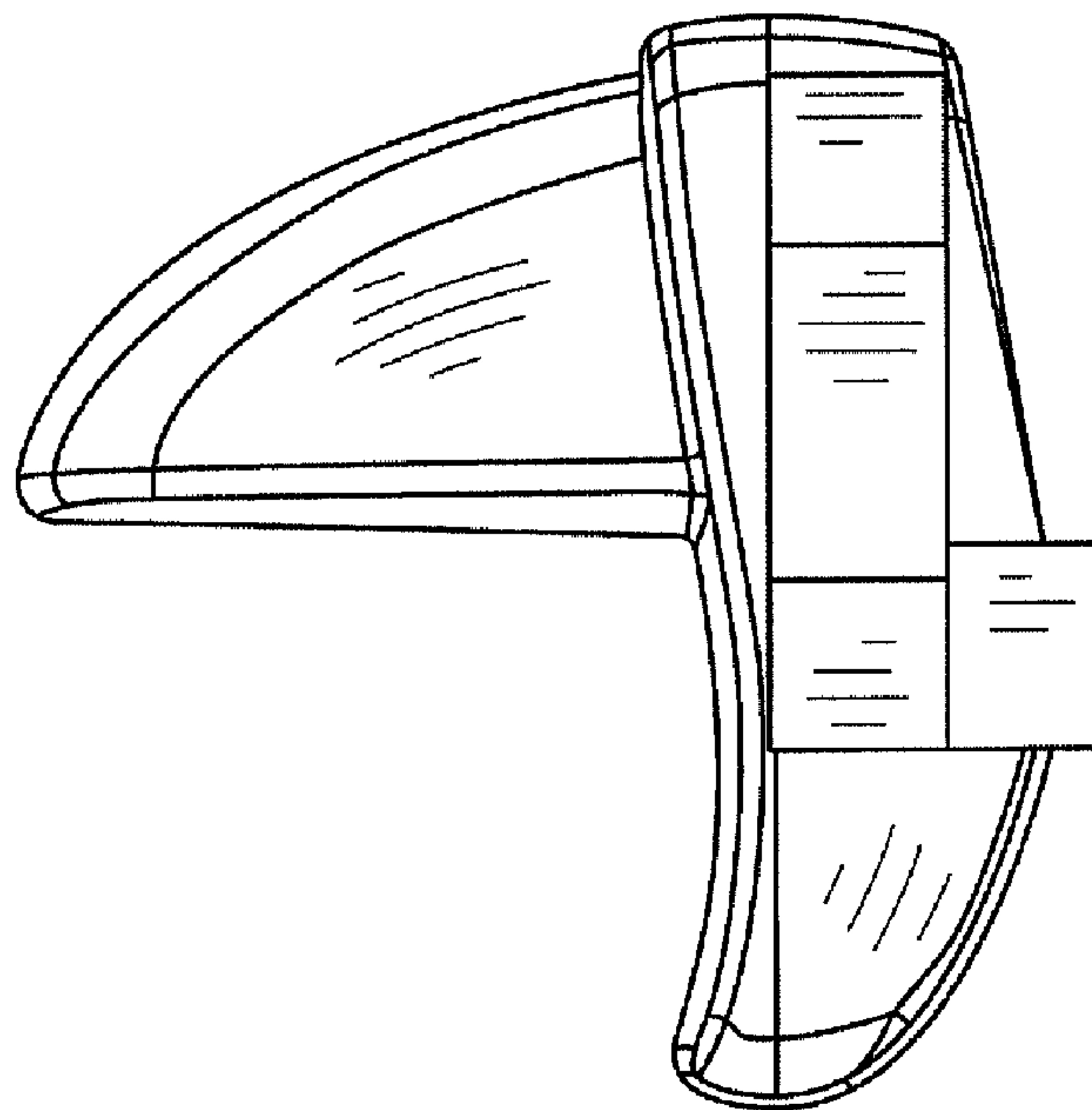

FIG. 8

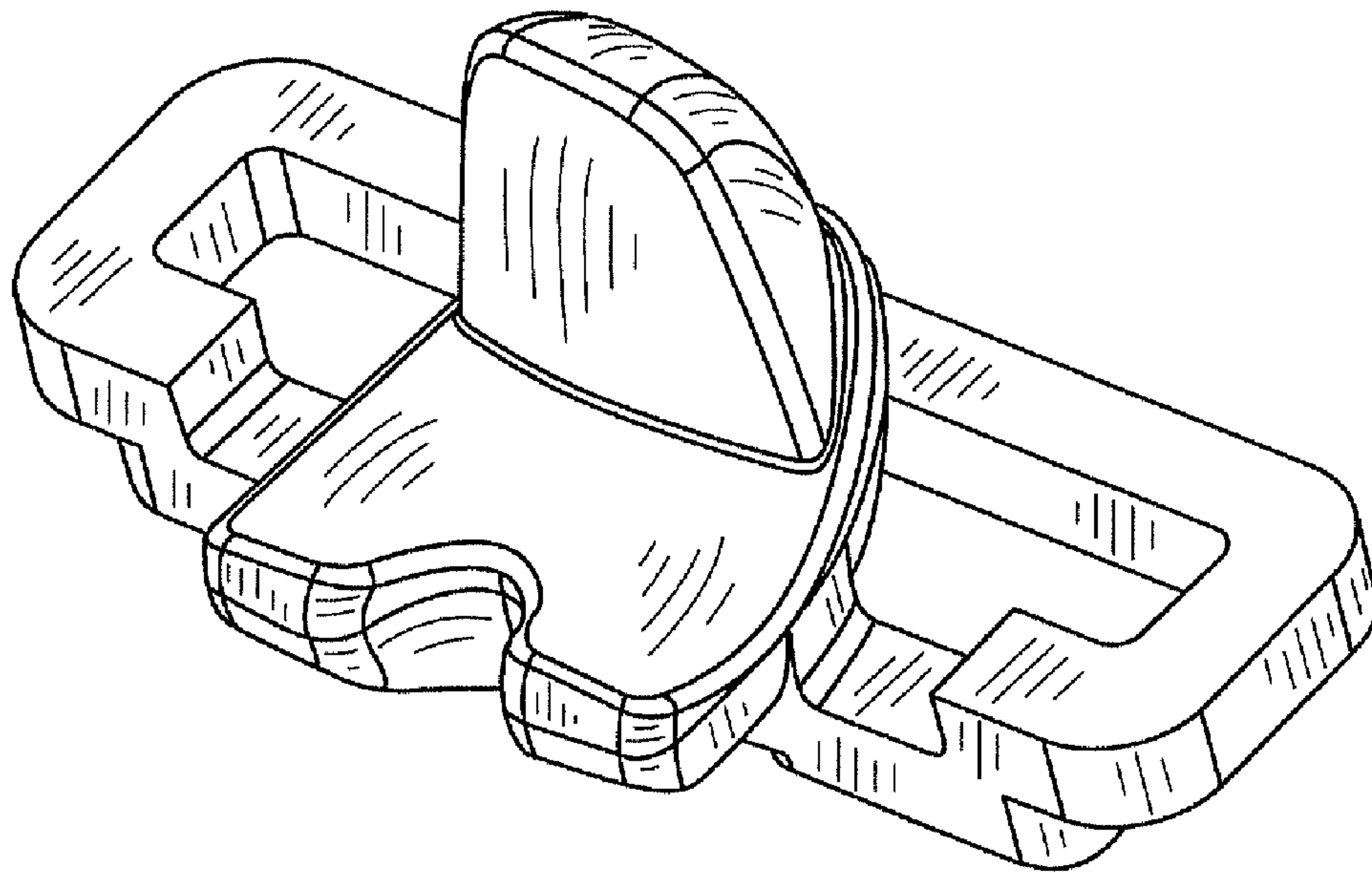

FIG. 9

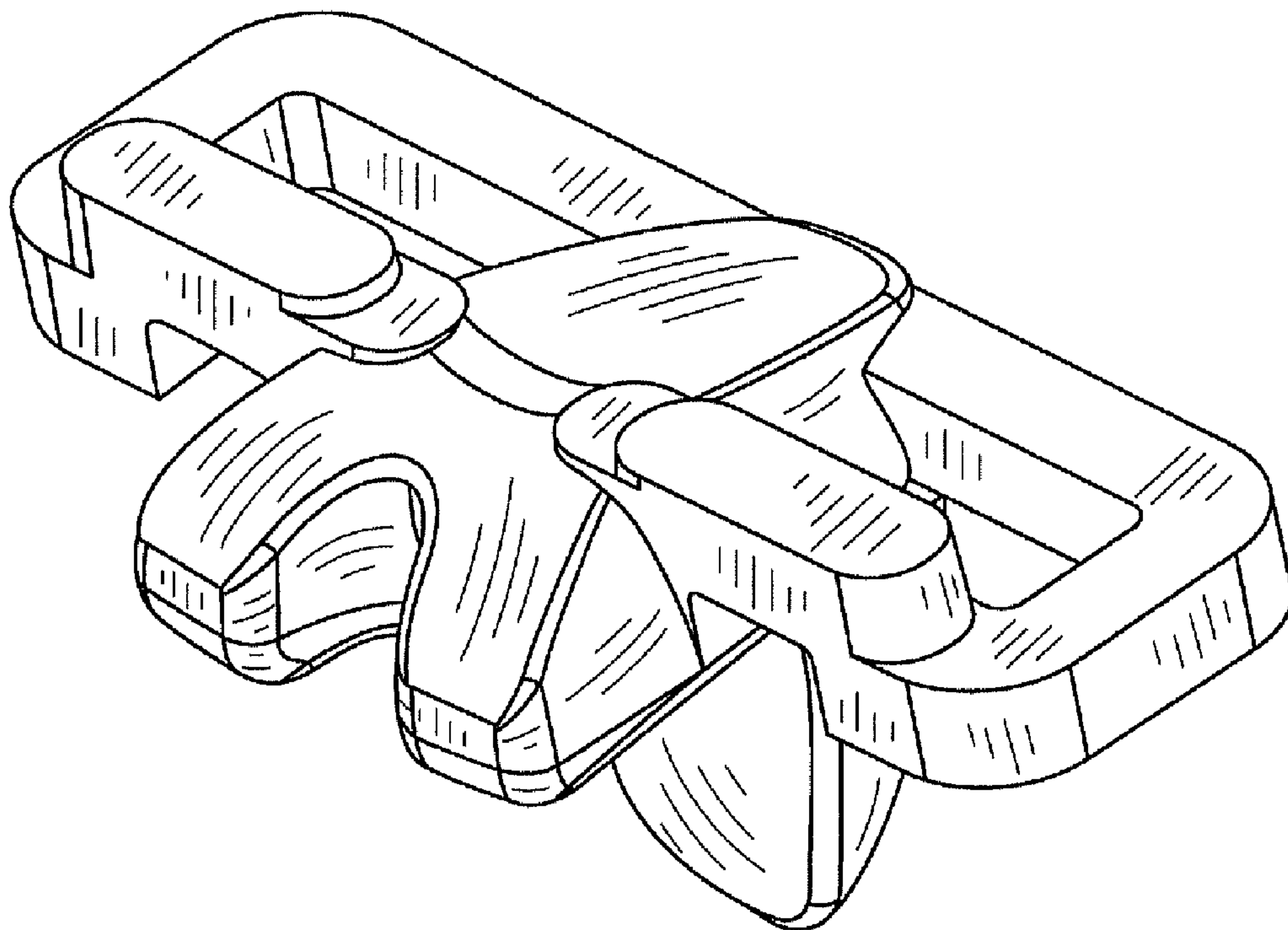

FIG. 10

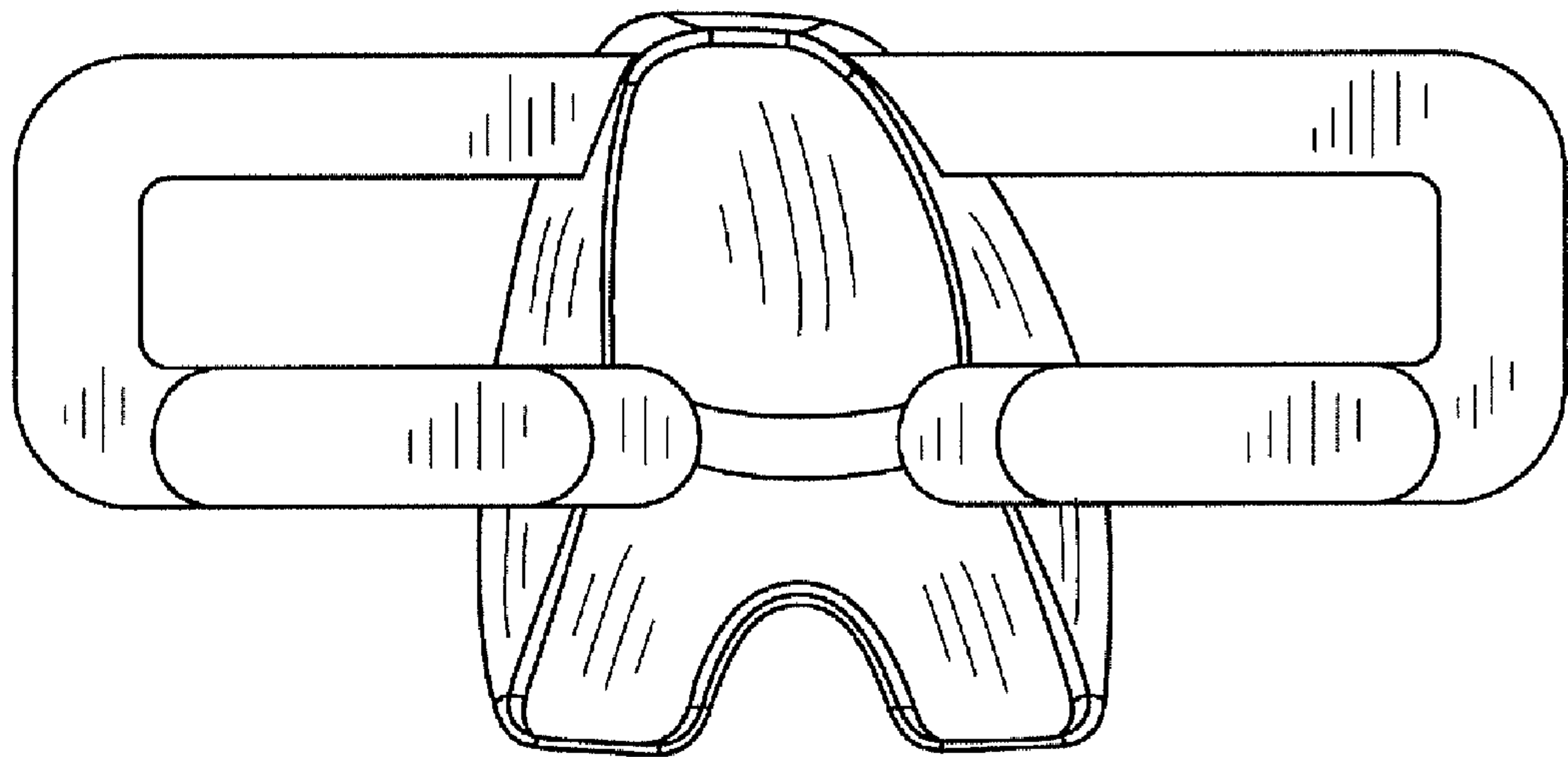

FIG. 11

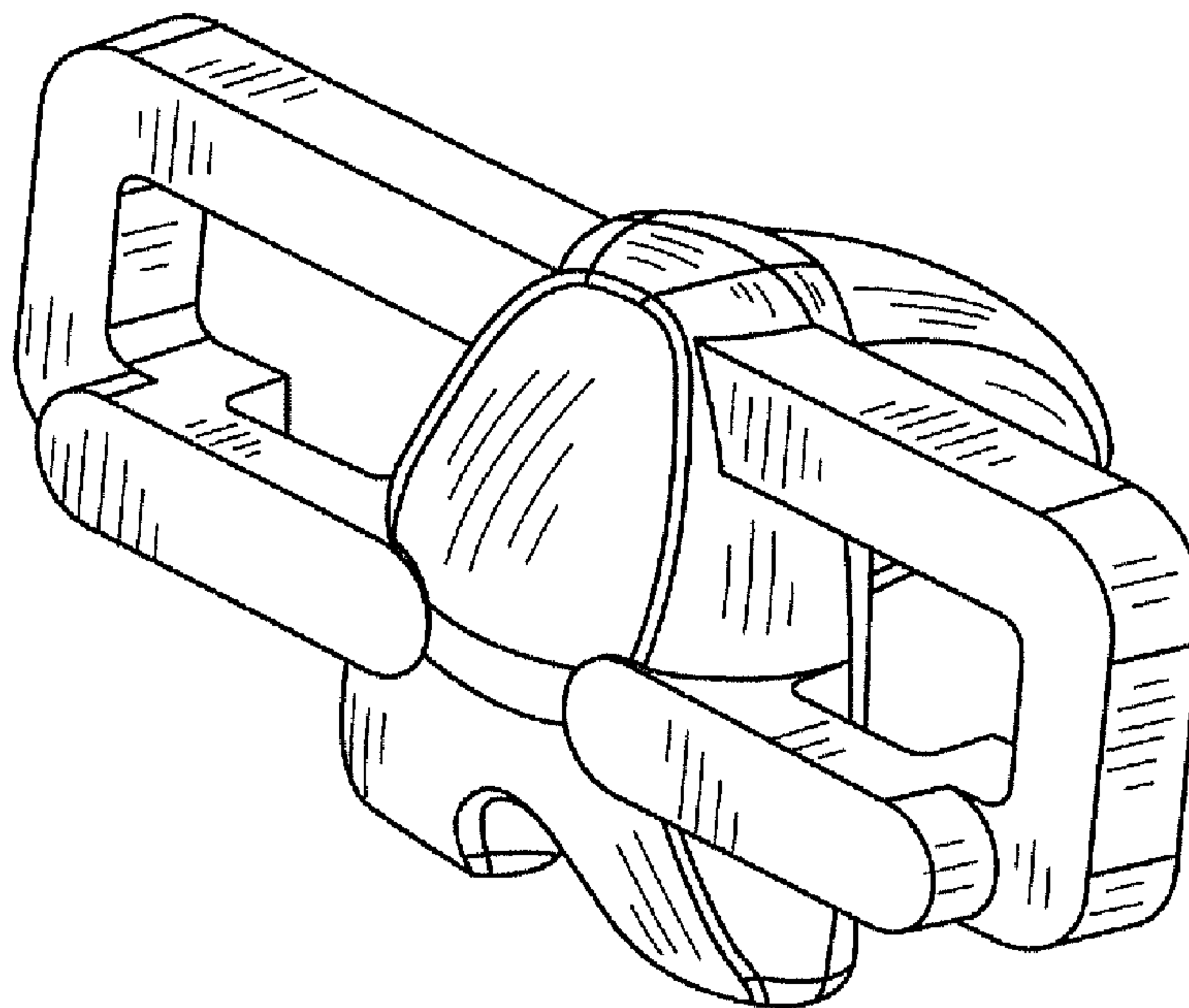

FIG. 12

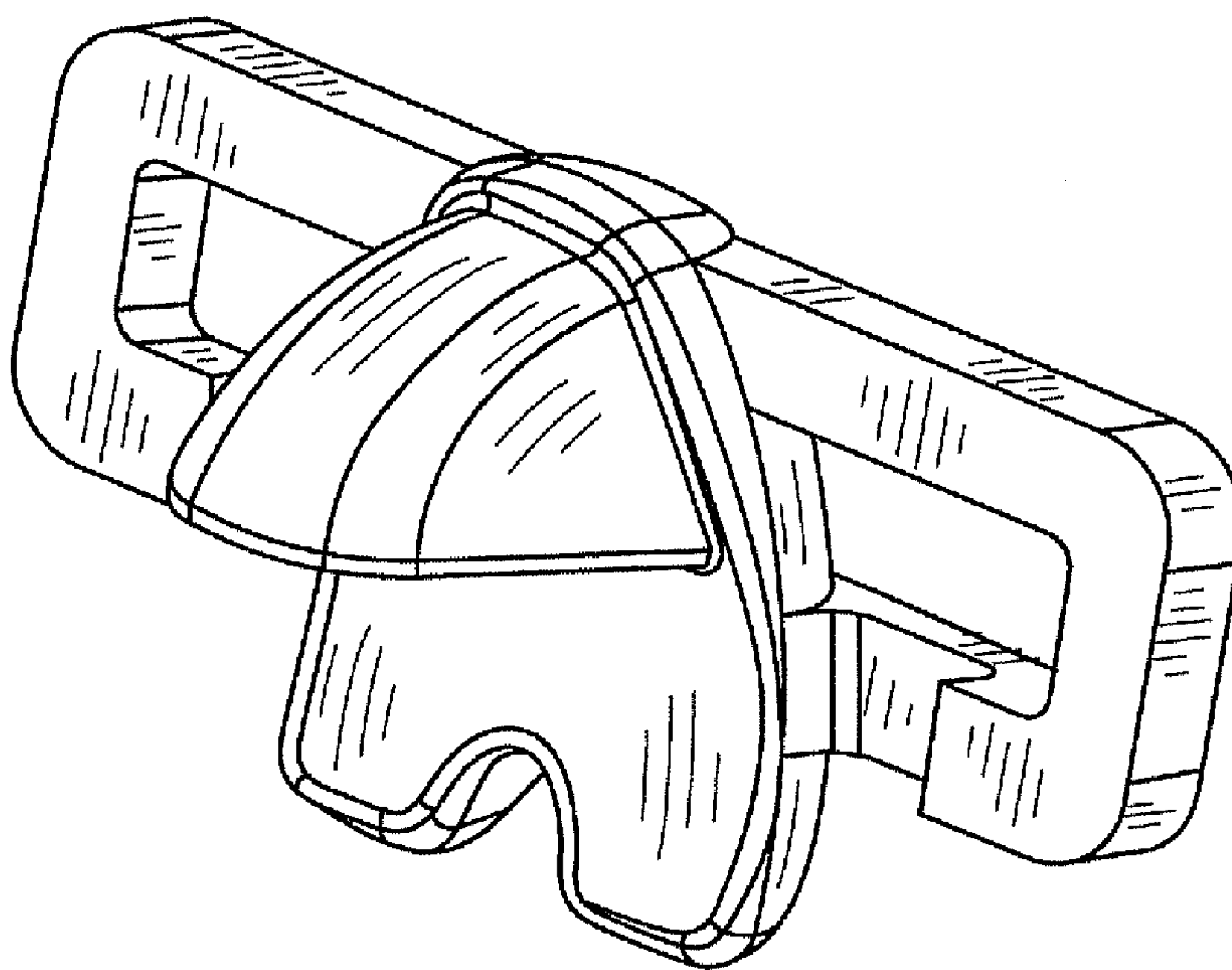

FIG. 13

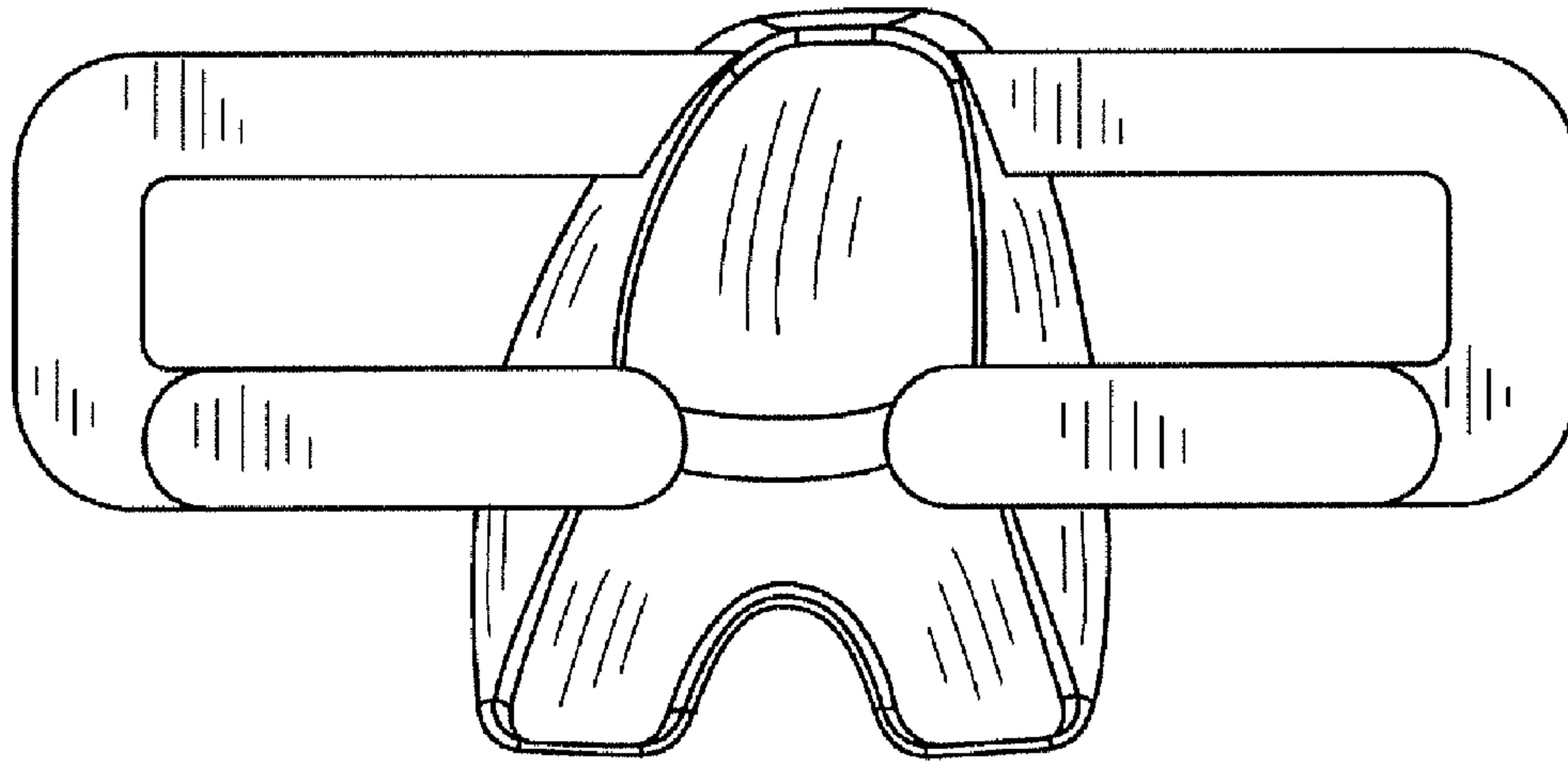

FIG. 14

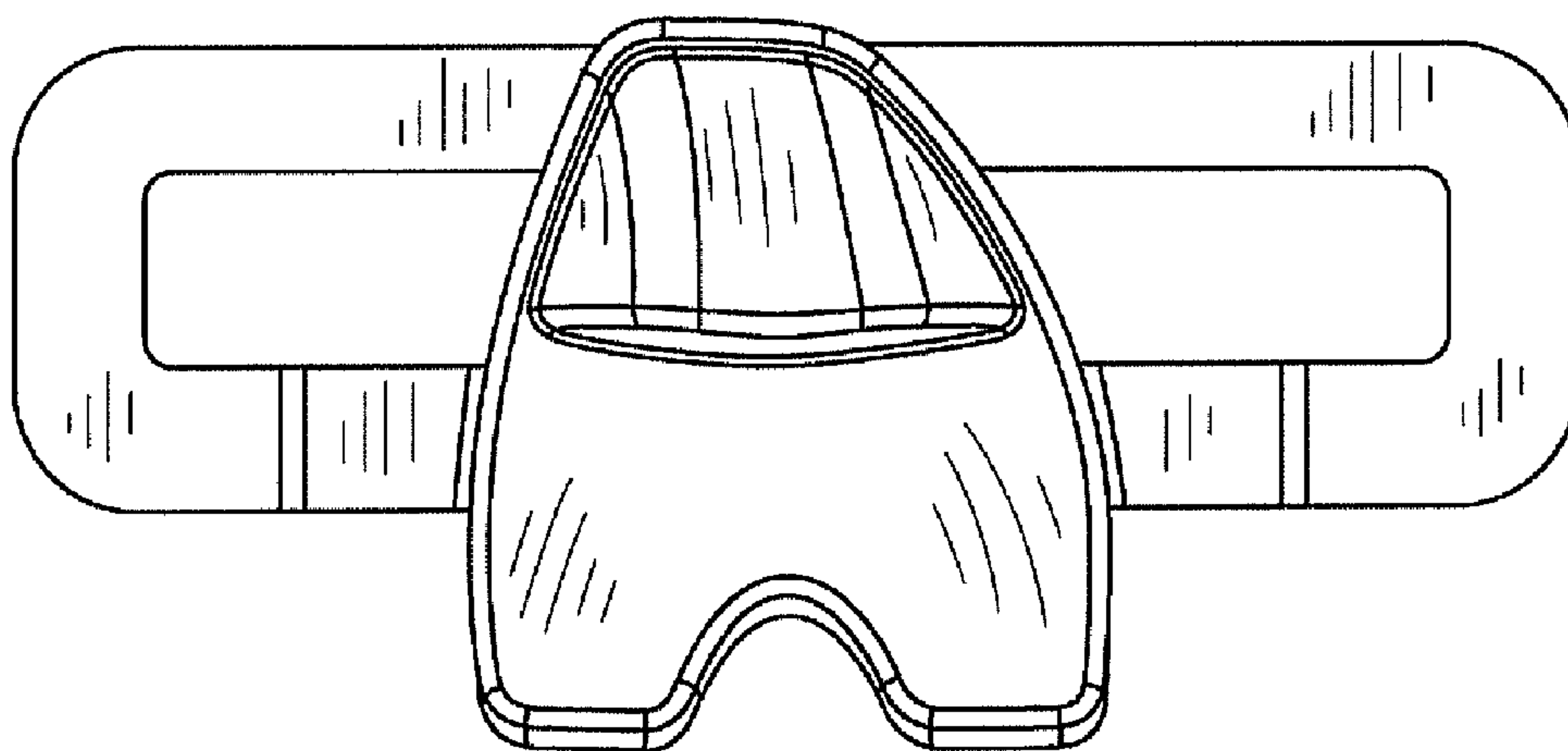

FIG. 15

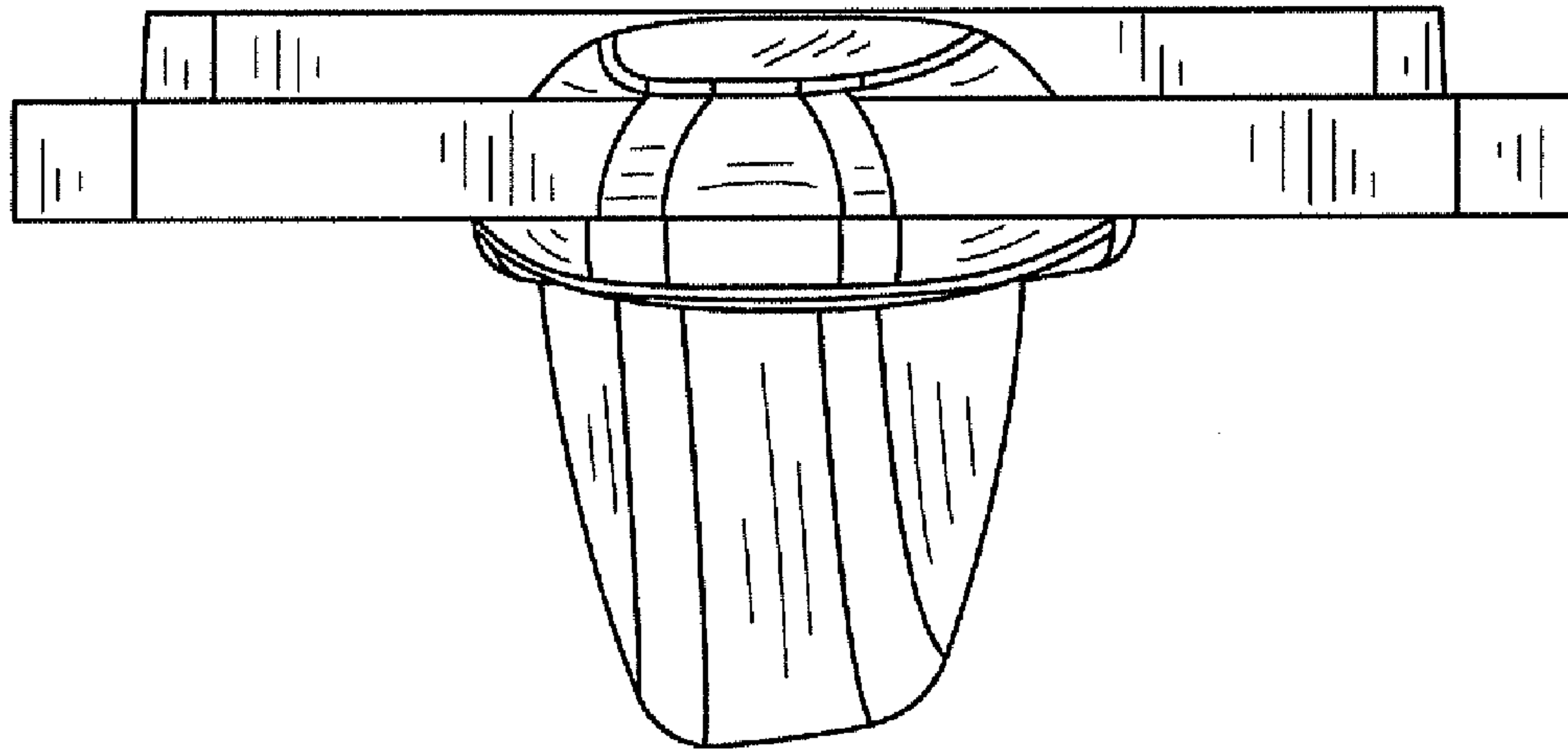

FIG. 16

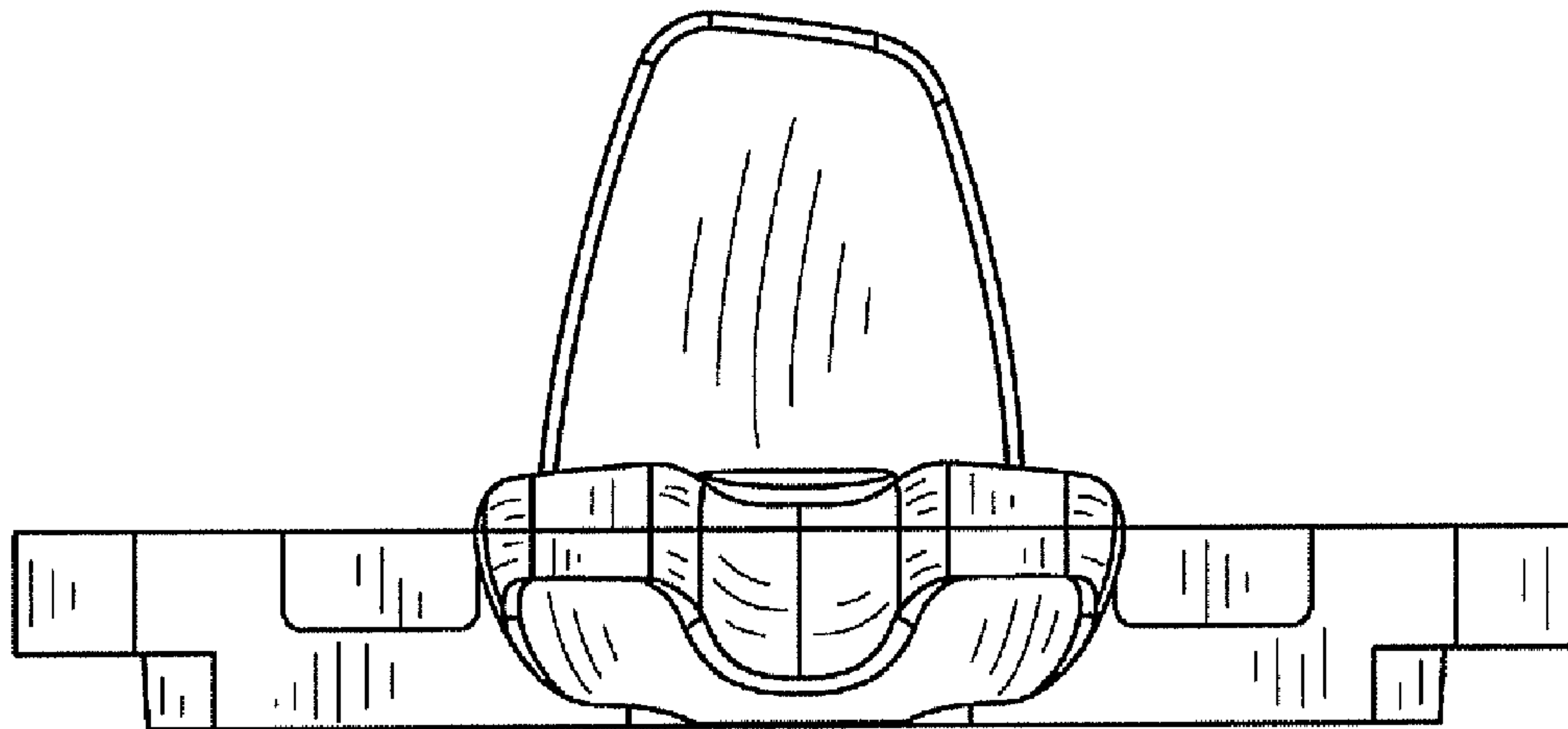

FIG. 17

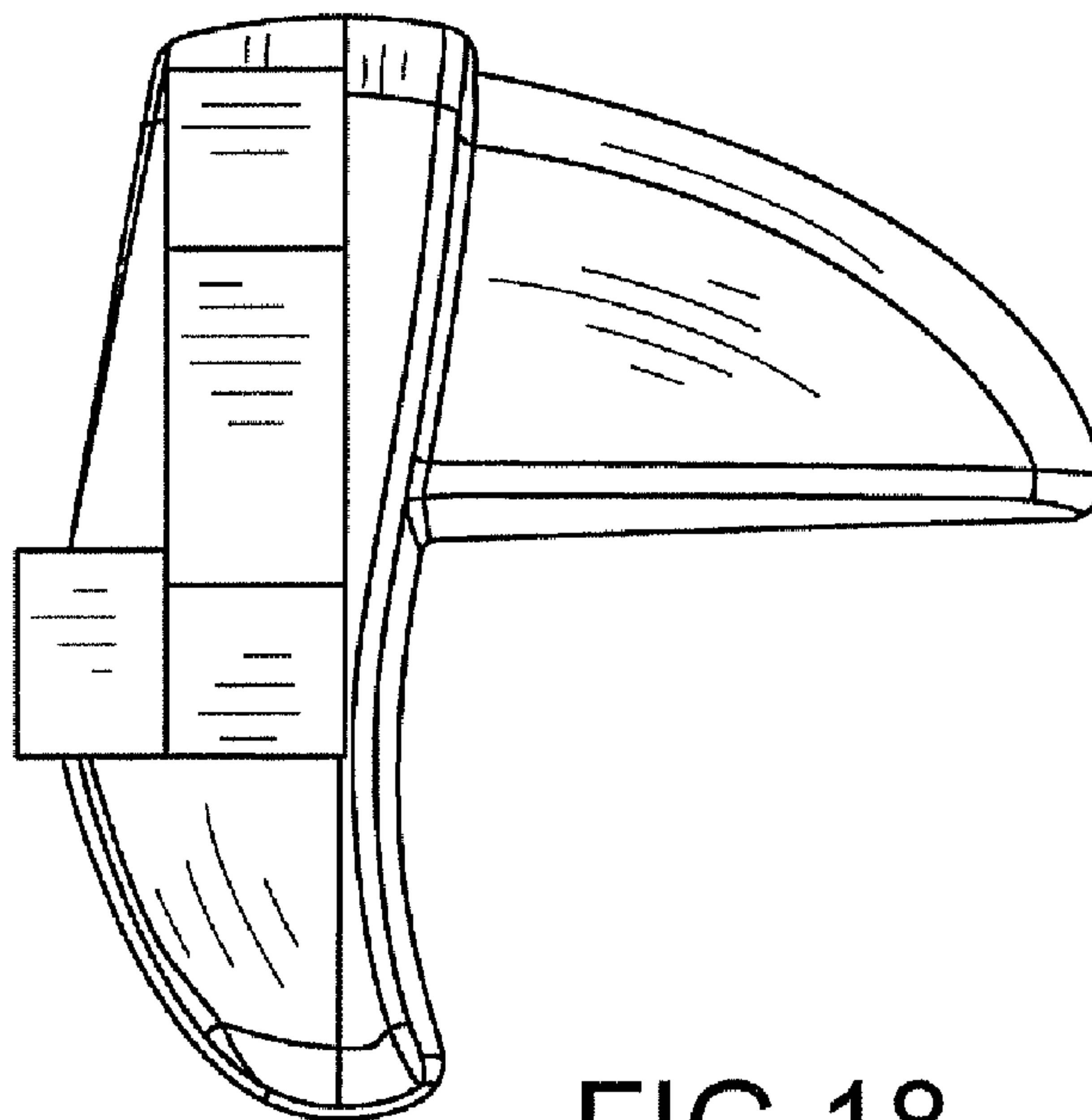

FIG. 18

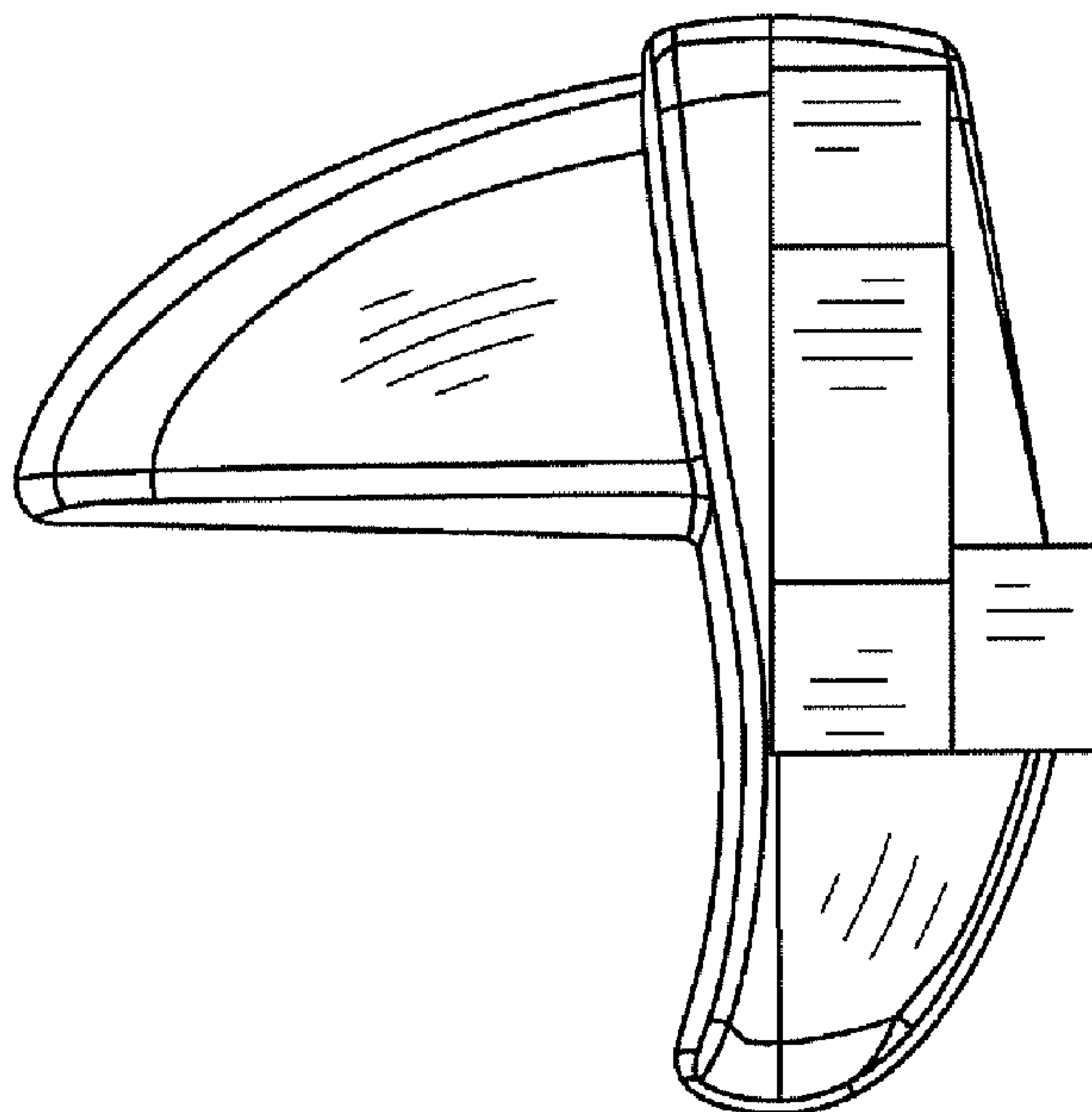

FIG. 19

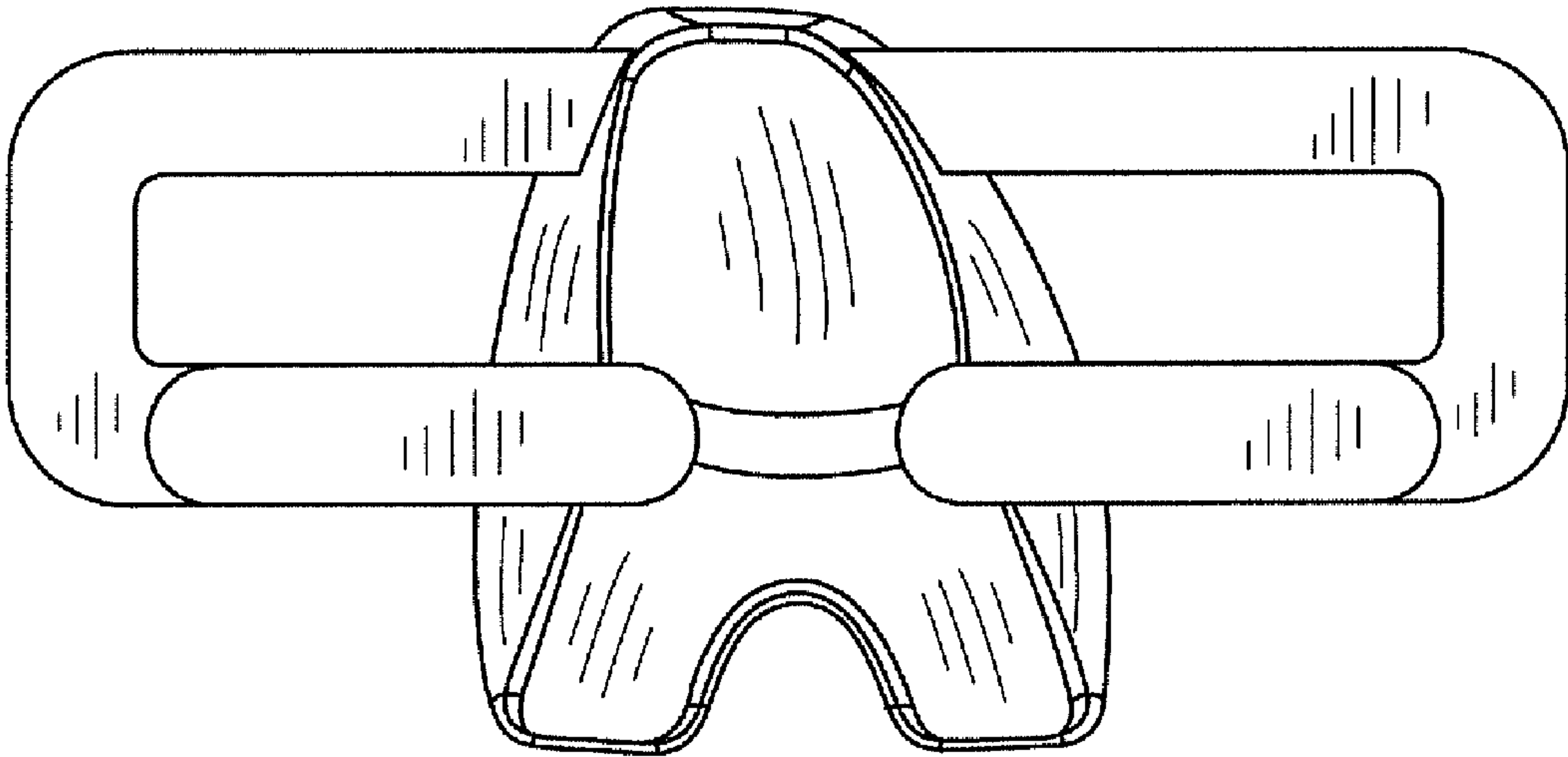

FIG.20