



US00D641780S

(12) **United States Design Patent**  
**Tseng**

(10) **Patent No.:** **US D641,780 S**

(45) **Date of Patent:** **\*\* Jul. 19, 2011**

(54) **DOCUMENT FILE**

(75) Inventor: **Chun-Ning Tseng**, Rende Township,  
Tainan County (TW)

(73) Assignee: **Smart Fortune International Limited**,  
Taichung (TW)

(\*\*) Term: **14 Years**

(21) Appl. No.: **29/379,776**

(22) Filed: **Nov. 24, 2010**

(51) **LOC (9) Cl.** ..... **19-04**

(52) **U.S. Cl.** ..... **D19/26**

(58) **Field of Classification Search** ..... D19/26-33,  
D19/86, 88, 90; D3/205, 303, 900; 402/73;  
383/4, 13, 19.1, 38; 281/3.1, 15.1, 19.1,  
281/29, 31, 38, 51; 283/63.1; 229/67.1,  
229/67.3, 69

See application file for complete search history.

D499,761 S *	12/2004	Walley et al.	.....	D19/26
6,910,621 B2 *	6/2005	Shapiro et al.	.....	229/67.1
D509,848 S *	9/2005	Whittington et al.	.....	D19/26
D513,279 S *	12/2005	Hough et al.	.....	D19/86
D518,105 S *	3/2006	Hough et al.	.....	D19/86
D521,072 S *	5/2006	Hough et al.	.....	D19/90
D529,963 S *	10/2006	Hough et al.	.....	D19/90
7,237,710 B1 *	7/2007	Ong	.....	229/67.3
7,252,452 B2 *	8/2007	Africa et al.	.....	402/73
D570,409 S *	6/2008	Smith et al.	.....	D19/26
D596,842 S *	7/2009	Cooper	.....	D3/205
D611,533 S *	3/2010	Baker et al.	.....	D19/27
D618,277 S *	6/2010	Baker et al.	.....	D19/27
2004/0253046 A1 *	12/2004	Africa et al.	.....	402/73

\* cited by examiner

*Primary Examiner* — T. Chase Nelson

*Assistant Examiner* — Kathleen M Sims

(74) *Attorney, Agent, or Firm* — Egbert Law Offices PLLC

(57) **CLAIM**

The ornamental design for a document file, as shown and described.

(56) **References Cited**

U.S. PATENT DOCUMENTS

2,151,469 A *	3/1939	Hochtheil	.....	229/69
3,312,384 A *	4/1967	Heynemann	.....	383/13
D321,369 S *	11/1991	Tooker	.....	D19/26
D323,348 S *	1/1992	Tooker	.....	D19/26
D423,572 S *	4/2000	Tedaldi et al.	.....	D19/26
D449,166 S *	10/2001	Shapiro	.....	D3/303
D465,331 S *	11/2002	Shapiro	.....	D3/303
D476,032 S *	6/2003	Marchand	.....	D19/26
6,607,122 B1 *	8/2003	Ong	.....	229/67.3
D481,074 S *	10/2003	Shapiro et al.	.....	D19/90

**DESCRIPTION**

FIG. 1 is an upper perspective view of the document file showing my design.

FIG. 2 is a front elevation view thereof;

FIG. 3 is back elevation view thereof;

FIG. 4 is a side elevation view thereof;

FIG. 5 is an opposite side elevation view thereof;

FIG. 6 is a top plan view thereof; and,

FIG. 7 is a bottom plan view thereof.

**1 Claim, 4 Drawing Sheets**

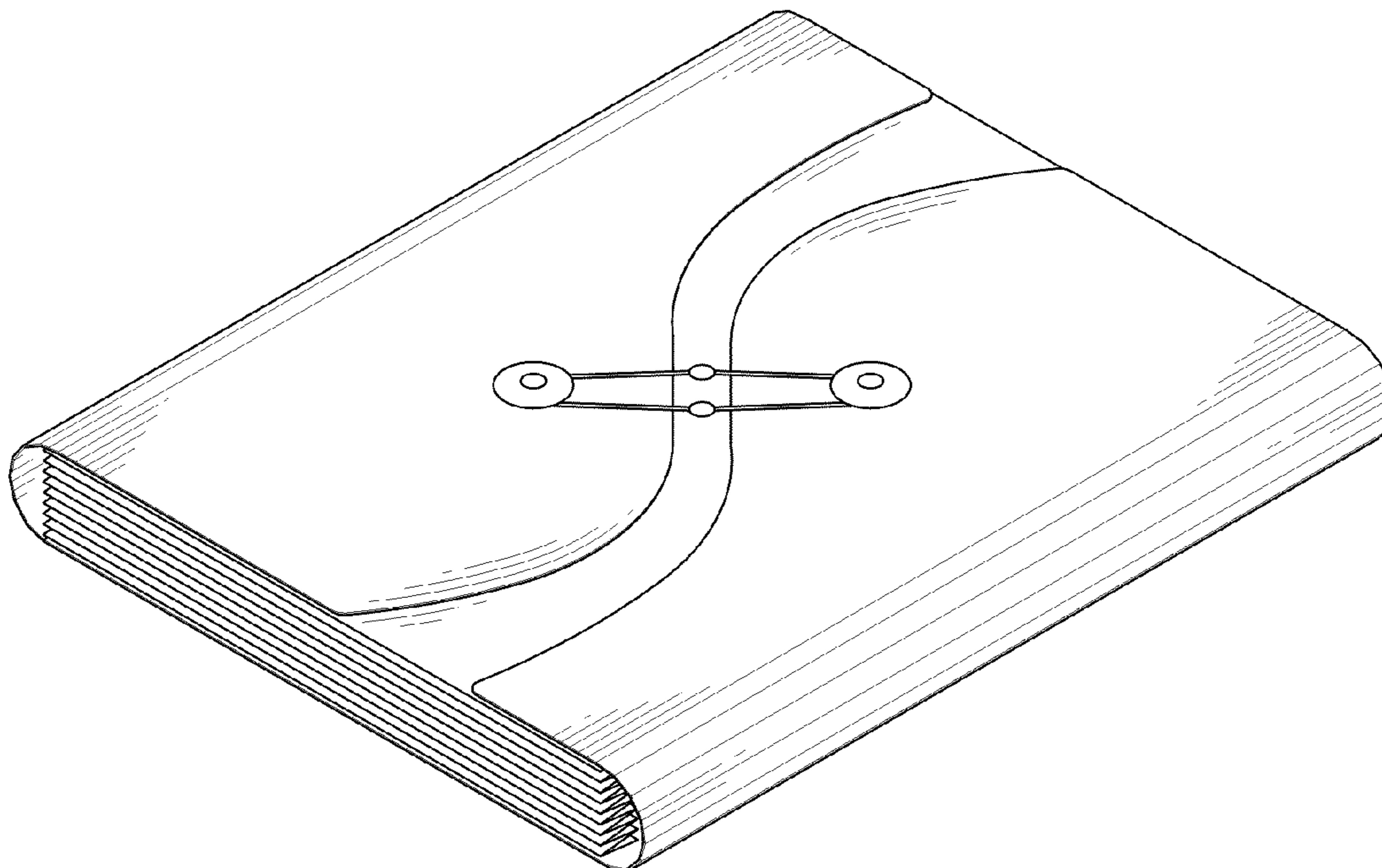

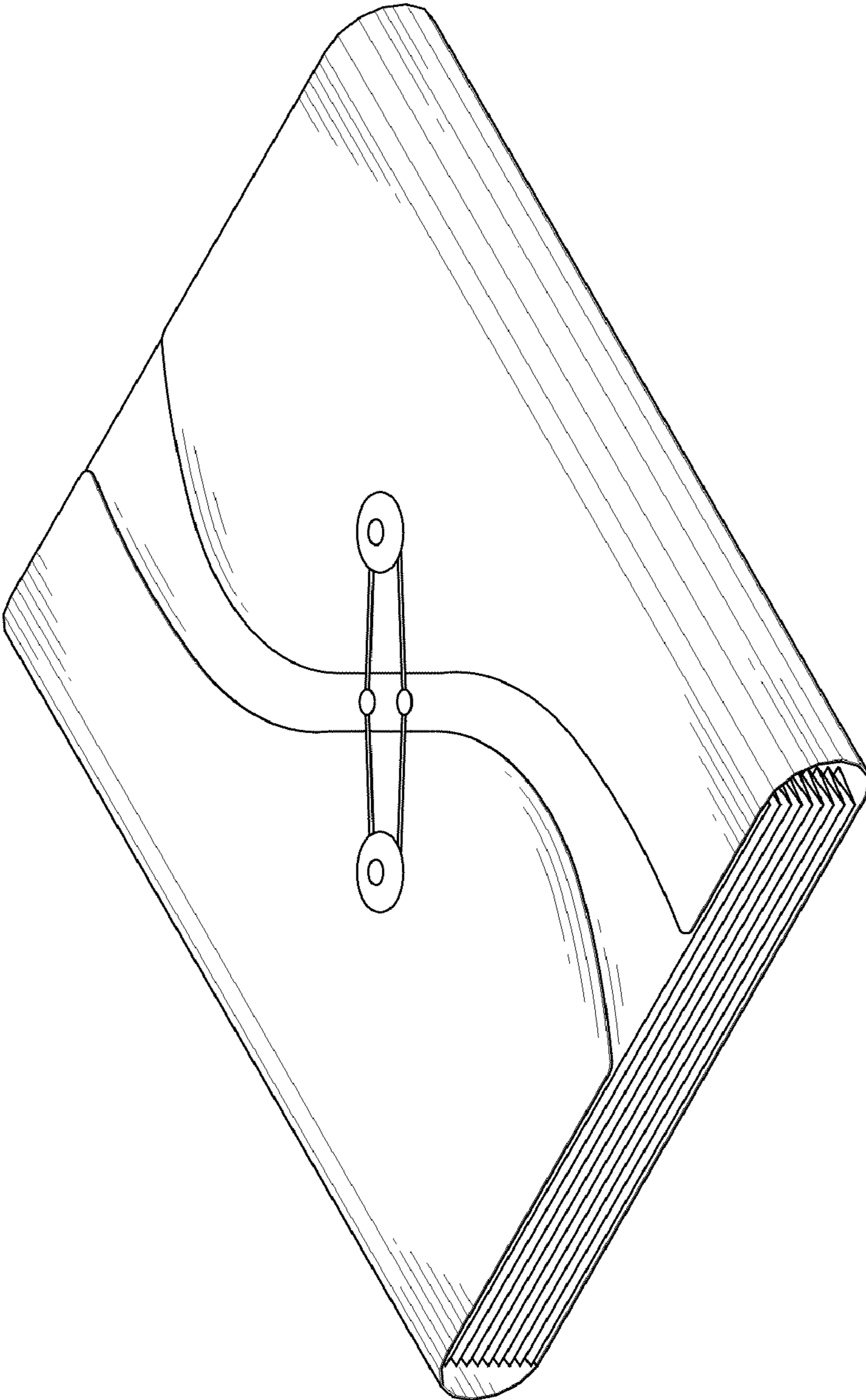

FIG.1

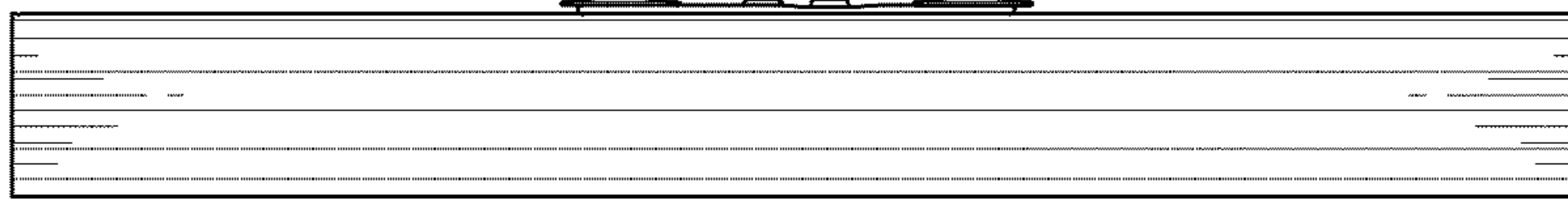

FIG. 2

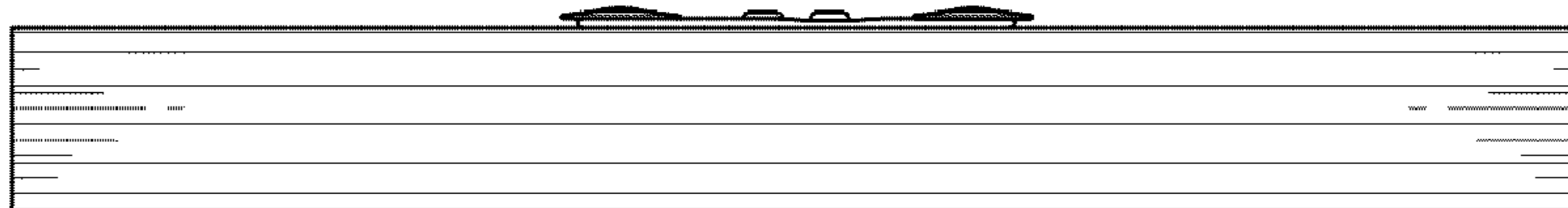

FIG. 3

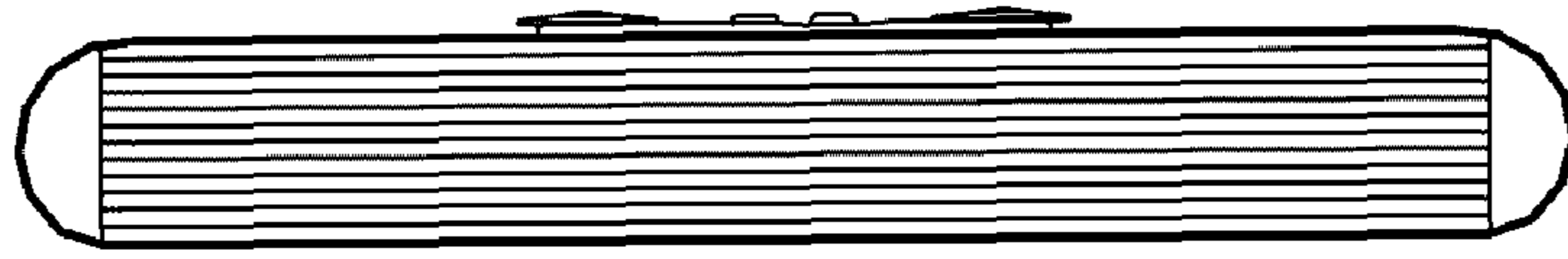

FIG. 4

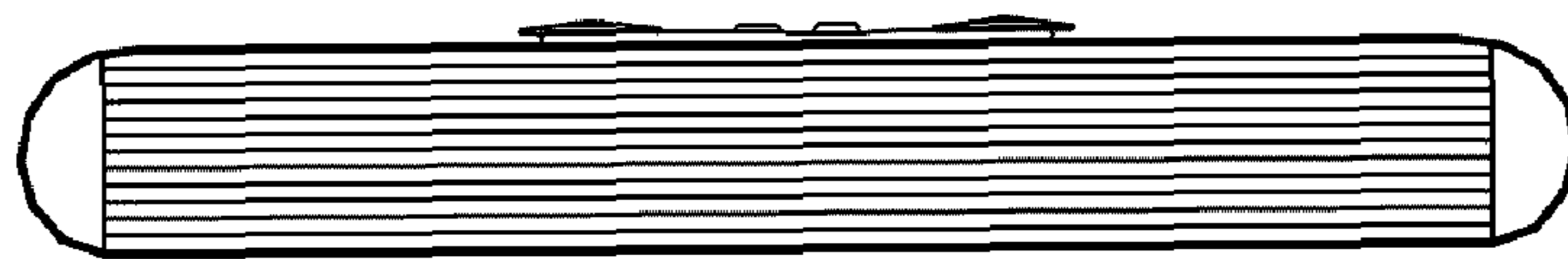

FIG. 5

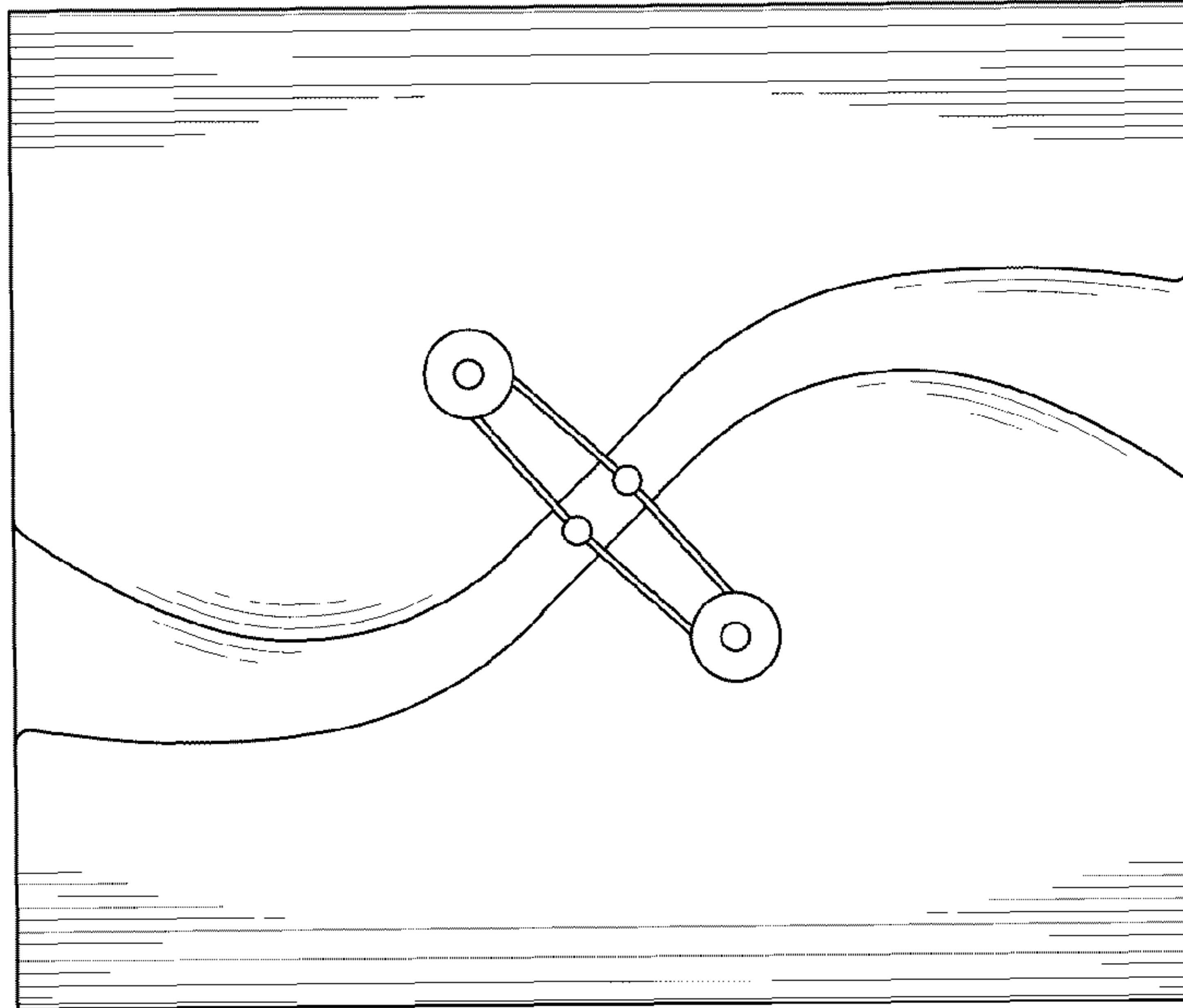

FIG. 6

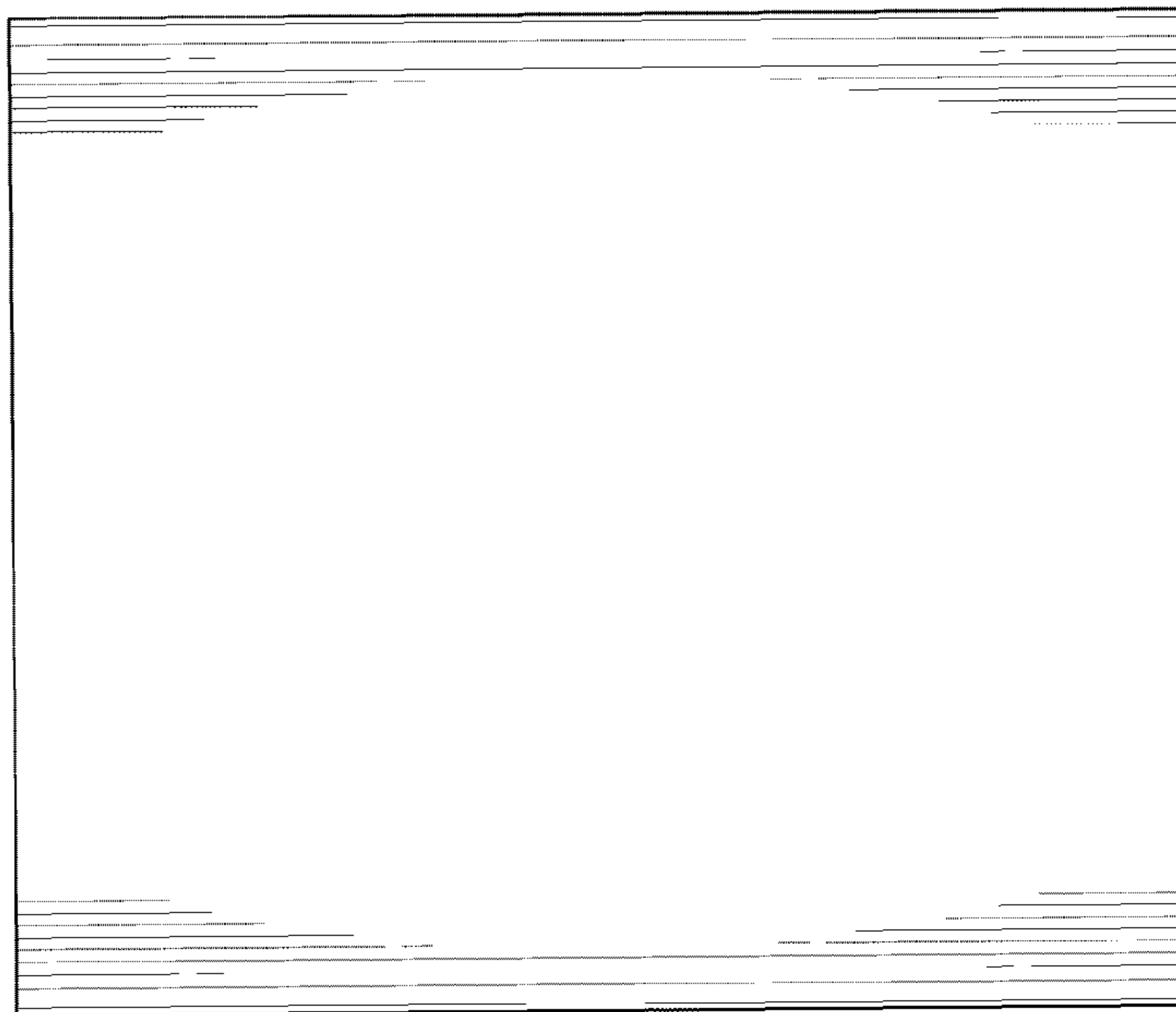

FIG. 7