



US00D641588S

(12) **United States Design Patent**  
**Cole et al.**

(10) **Patent No.:** **US D641,588 S**  
(45) **Date of Patent:** **\*\* Jul. 19, 2011**

(54) **BOWL**

(75) Inventors: **Jeffrey K. Cole**, Queensbury, NY (US);  
**Brian S. Allers**, Poughkeepsie, NY (US)

(73) Assignee: **Genpak LLC**, Glen Falls, NY (US)

(\*\*) Term: **14 Years**

(21) Appl. No.: **29/330,670**

(22) Filed: **Jan. 12, 2009**

(51) **LOC (9) Cl.** ..... **07-01**

(52) **U.S. Cl.** ..... **D7/396.1**

(58) **Field of Classification Search** ..... D7/396.1,  
D7/387, 584, 550.1, 554.1, 554.3, 554.4,  
D7/545, 557, 586, 602; D9/430-432, 424;  
220/4.21, 574; 219/678; 294/172; 206/507,  
206/557, 561-564, 565; 229/407

See application file for complete search history.

(56) **References Cited**

**U.S. PATENT DOCUMENTS**

D224,734 S *	9/1972	Reifer's	.....	D9/427
D285,514 S *	9/1986	Ritman	.....	D7/354
D288,163 S *	2/1987	Ritman	.....	D7/545
D291,757 S *	9/1987	Ritman	.....	D7/584
D315,099 S *	3/1991	Alizard	.....	D9/424
D447,382 S *	9/2001	Tucker et al.	.....	D7/392.1
D551,505 S *	9/2007	Friedland et al.	.....	D7/545
D551,506 S *	9/2007	Friedland et al.	.....	D7/545
D551,507 S *	9/2007	Friedland et al.	.....	D7/545
D551,908 S *	10/2007	Friedland et al.	.....	D7/545

D552,423 S *	10/2007	Friedland et al.	.....	D7/545
D609,531 S *	2/2010	Koennecke	.....	D7/584
D609,532 S *	2/2010	Koennecke	.....	D7/584
D609,976 S *	2/2010	Koennecke	.....	D7/586

**OTHER PUBLICATIONS**

Copending U.S. Appl. No. 29/330,720, filed Jan. 13, 2009, titled Plate.

Notice of Allowance issued Apr. 16, 2010 in U.S. Appl. No. 29/330,720.

\* cited by examiner

*Primary Examiner* — Cynthia Underwood

(74) *Attorney, Agent, or Firm* — Stoel Rives LLP

(57) **CLAIM**

The ornamental design for a bowl, substantially as shown and described.

**DESCRIPTION**

FIG. 1 is a forward perspective view of a bowl;  
FIG. 2 is a rearward perspective view thereof;  
FIG. 3 is a front plan view thereof;  
FIG. 4 is a left elevation view thereof;  
FIG. 5 is a right elevation view thereof;  
FIG. 6 is a bottom elevation view thereof; and,  
FIG. 7 is a top elevation view thereof.  
The broken lines represent portions of the structure that form no part of the claim.

**1 Claim, 2 Drawing Sheets**

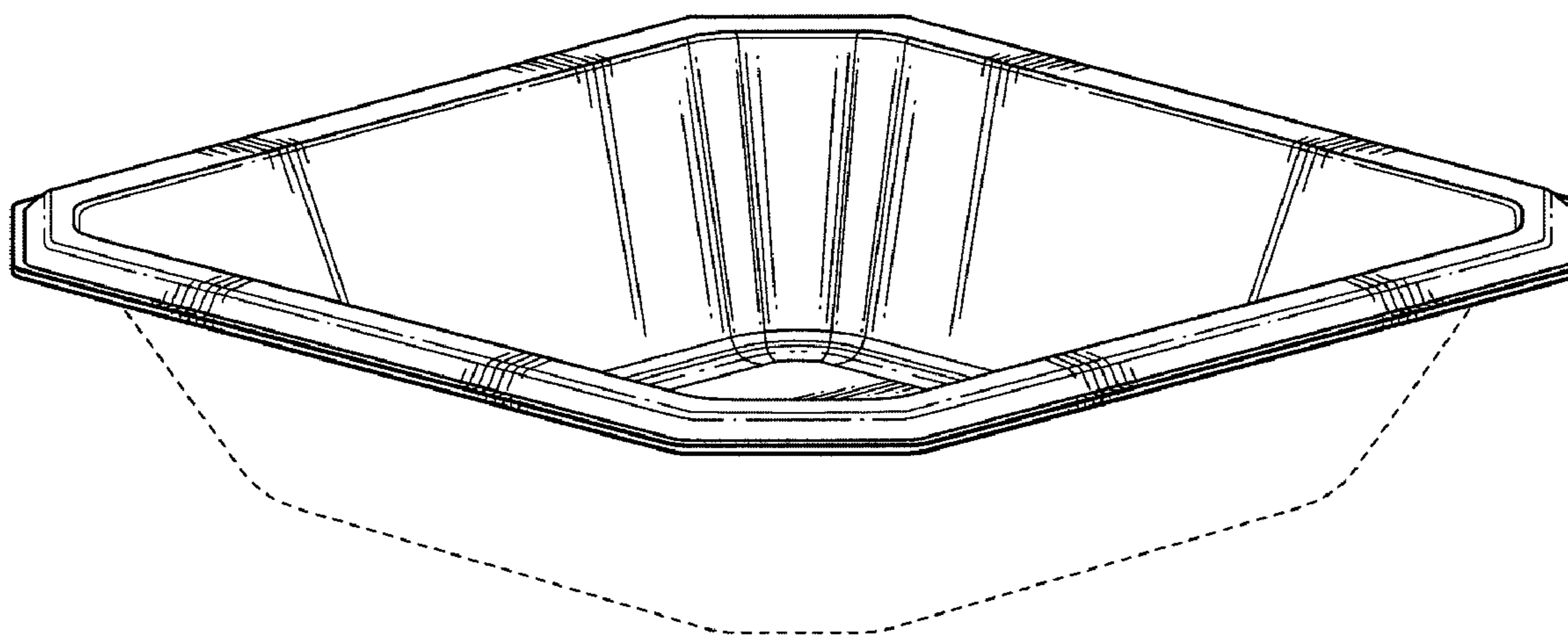

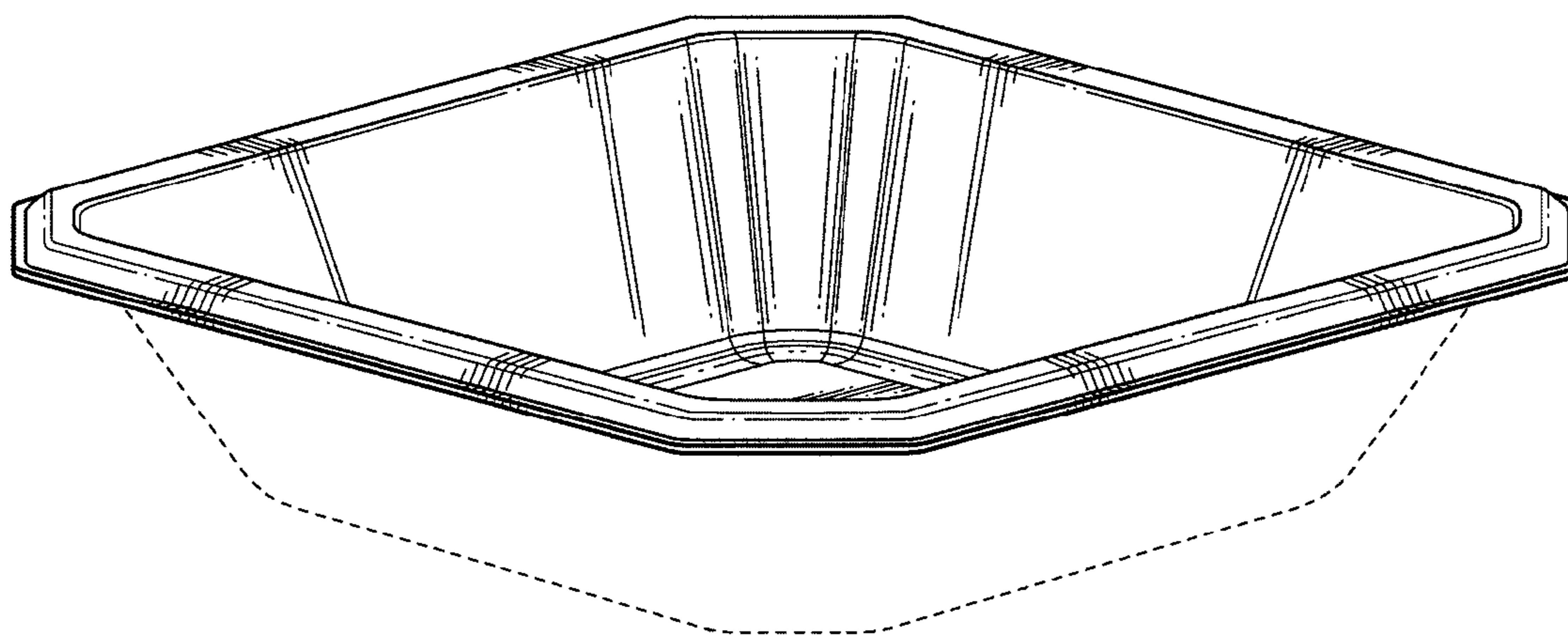

**FIG. 1**

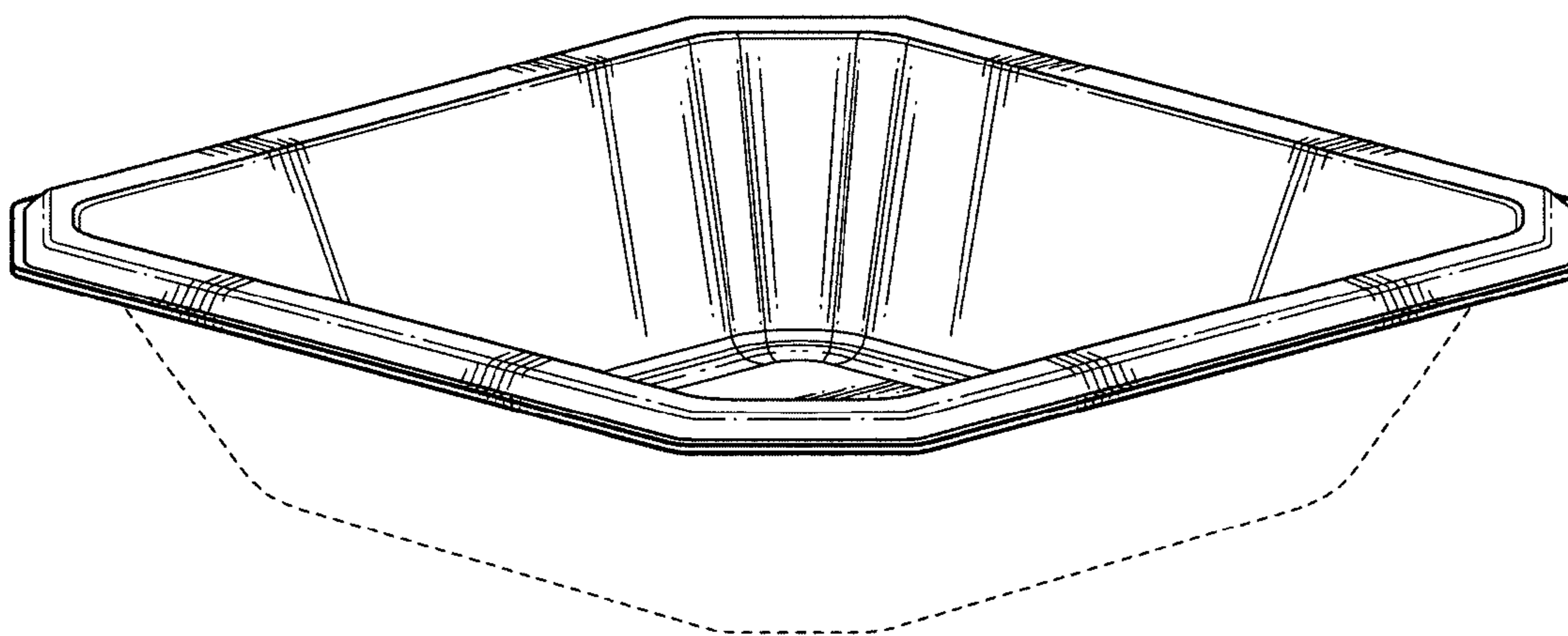

**FIG. 2**



**FIG. 7**

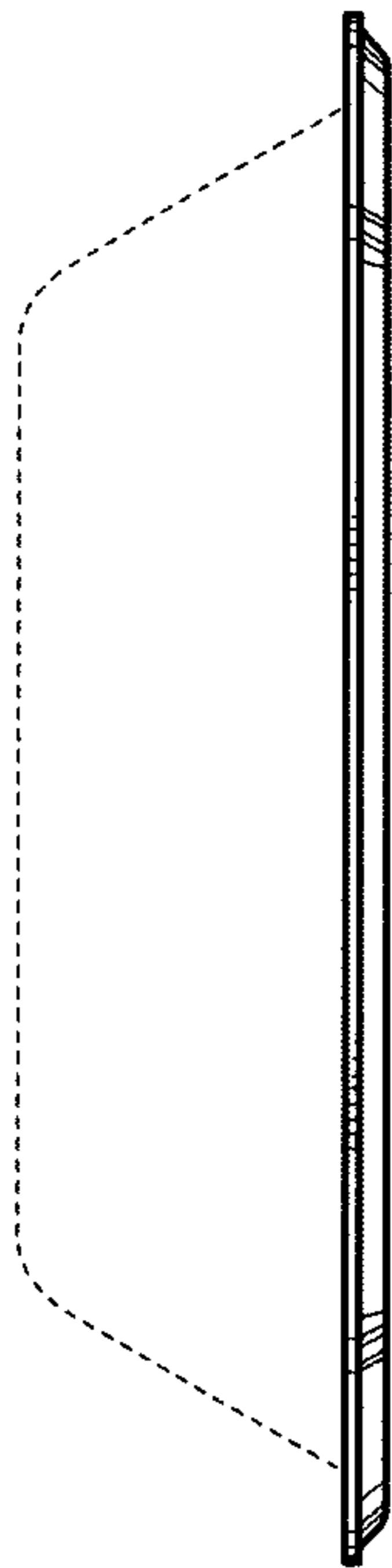

**FIG. 4**

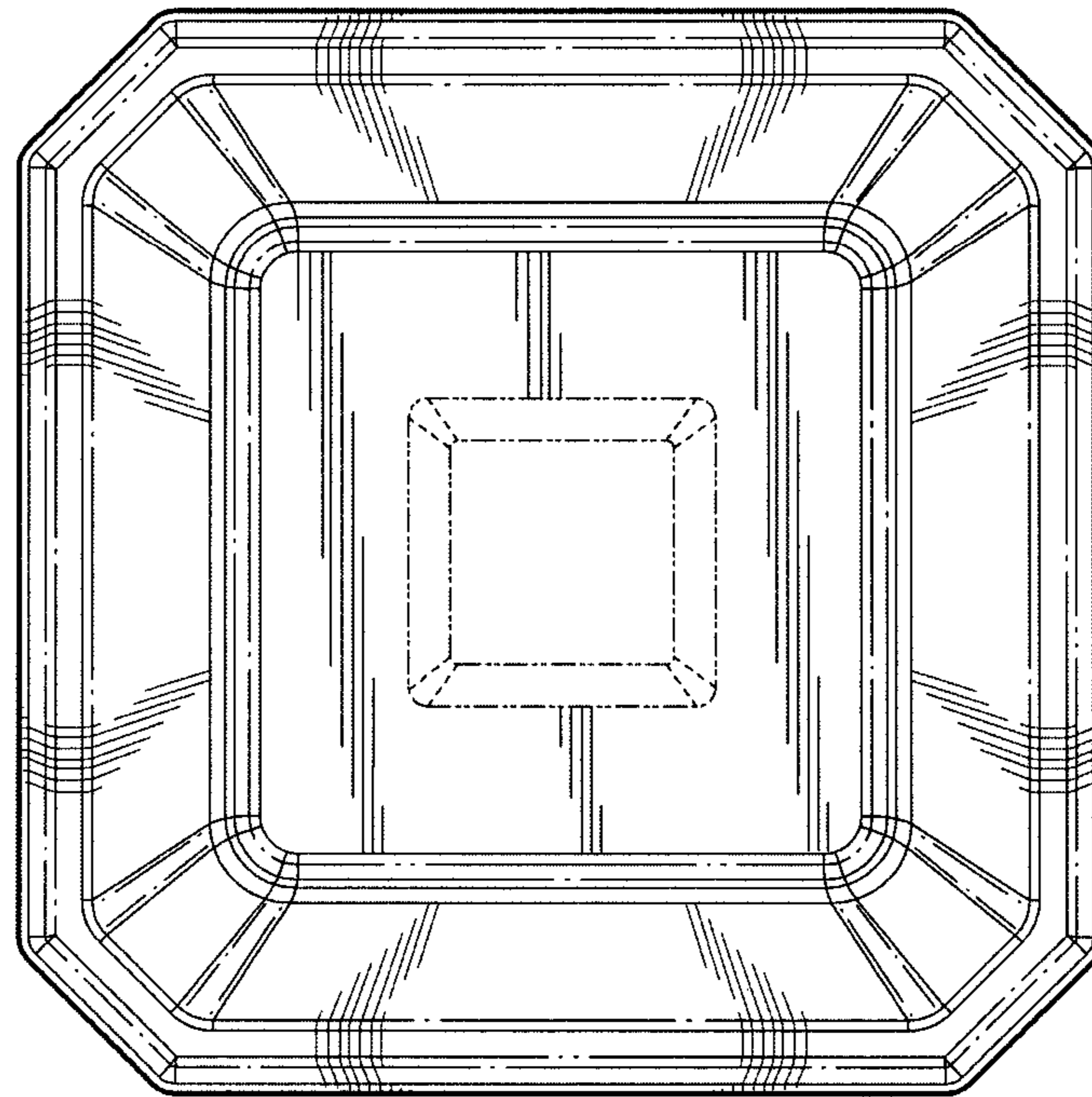

**FIG. 3**

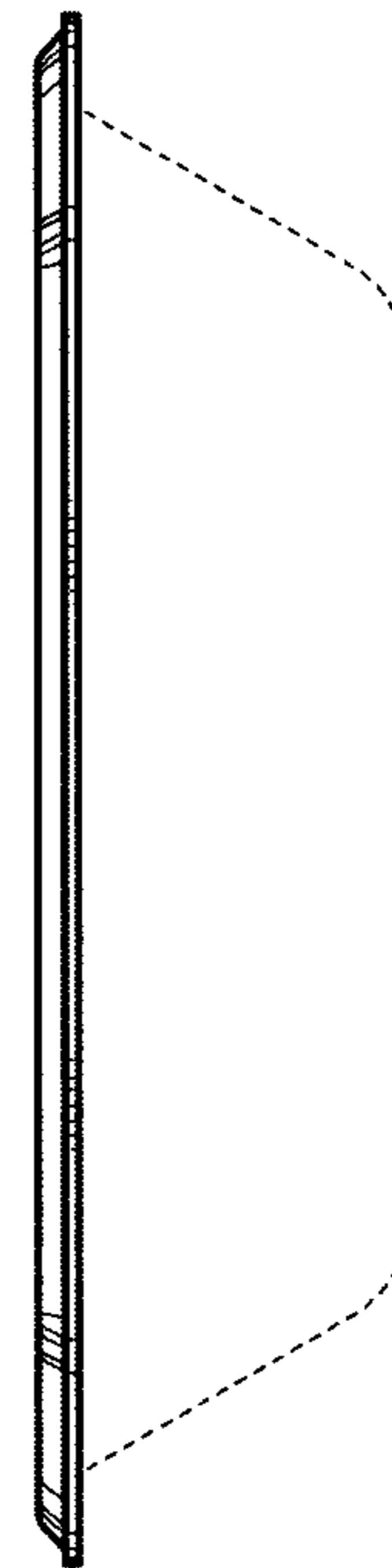

**FIG. 5**

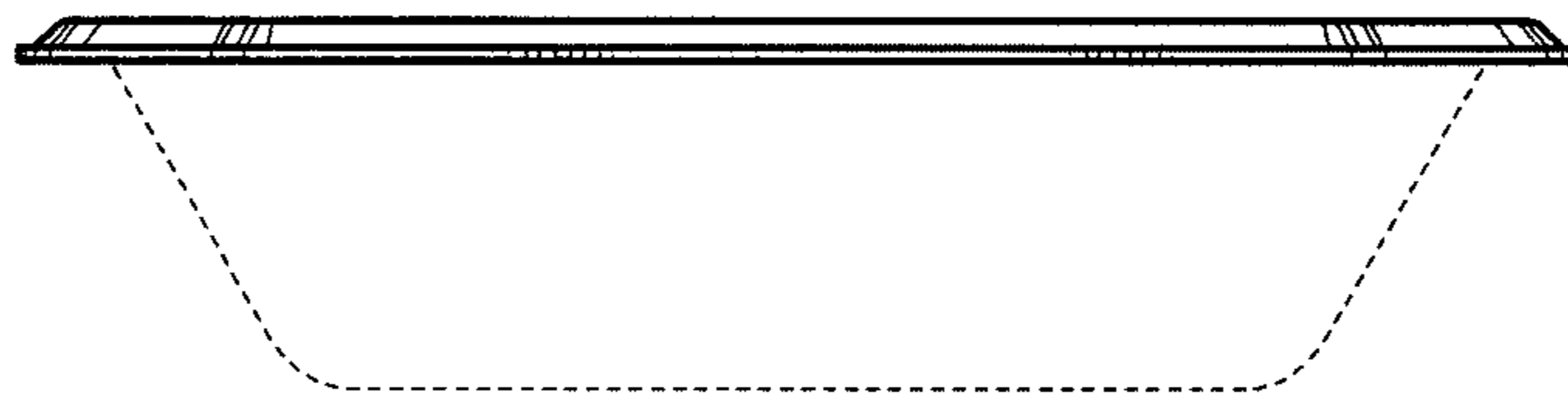

**FIG. 6**