



US00D641503S

(12) **United States Design Patent**  
**Kruger et al.**

(10) **Patent No.:** **US D641,503 S**  
(45) **Date of Patent:** **\*\* Jul. 12, 2011**

(54) **VEHICLE HEADLAMP**

(56) **References Cited**

(75) Inventors: **Scott Kruger**, Macomb, MI (US);  
**Mark T. Allen**, Oxford, MI (US); **Ralph**  
**V. Gilles**, Leonard, MI (US); **Timothy**  
**W. Anness**, Rochester Hills, MI (US)

U.S. PATENT DOCUMENTS

D536,113	S	*	1/2007	Pfeiffer	.....	D26/28
D537,180	S	*	2/2007	Hsu	.....	D26/28
D550,383	S	*	9/2007	Asai	.....	D26/28
D556,349	S	*	11/2007	Golden et al.	.....	D26/28
D560,291	S	*	1/2008	Koyama	.....	D26/28
D561,358	S	*	2/2008	Tachibana	.....	D26/28

(73) Assignee: **Chrysler Group LLC**, Auburn Hills, MI (US)

\* cited by examiner

*Primary Examiner* — Marcus Jackson

(\*\*) Term: **14 Years**

(74) *Attorney, Agent, or Firm* — Ralph E. Smith

(21) Appl. No.: **29/333,887**

(57) **CLAIM**

The ornamental design for a vehicle headlamp, as shown and described.

(22) Filed: **Mar. 17, 2009**

**DESCRIPTION**

**Related U.S. Application Data**

(63) Continuation-in-part of application No. 29/304,483, filed on Mar. 3, 2008, now Pat. No. Des. 588,501.

FIG. 1 is a front perspective view of a vehicle headlamp showing our new design;  
FIG. 2 is a front (outward facing) view thereof;  
FIG. 3 is a side (outward facing) view thereof;  
FIG. 4 is a back (inward facing) view thereof;  
FIG. 5 is a side (inward facing) view thereof;  
FIG. 6 is a top view thereof; and,  
FIG. 7 is a bottom view thereof.

(51) **LOC (9) Cl.** ..... **26-06**

(52) **U.S. Cl.** ..... **D26/28**

(58) **Field of Classification Search** ..... D26/28-36;  
362/459-468, 475-478, 485-487

It will be understood that the broken lines presented in the drawings are for illustration only, and do not form a part of the claimed design.

See application file for complete search history.

**1 Claim, 7 Drawing Sheets**

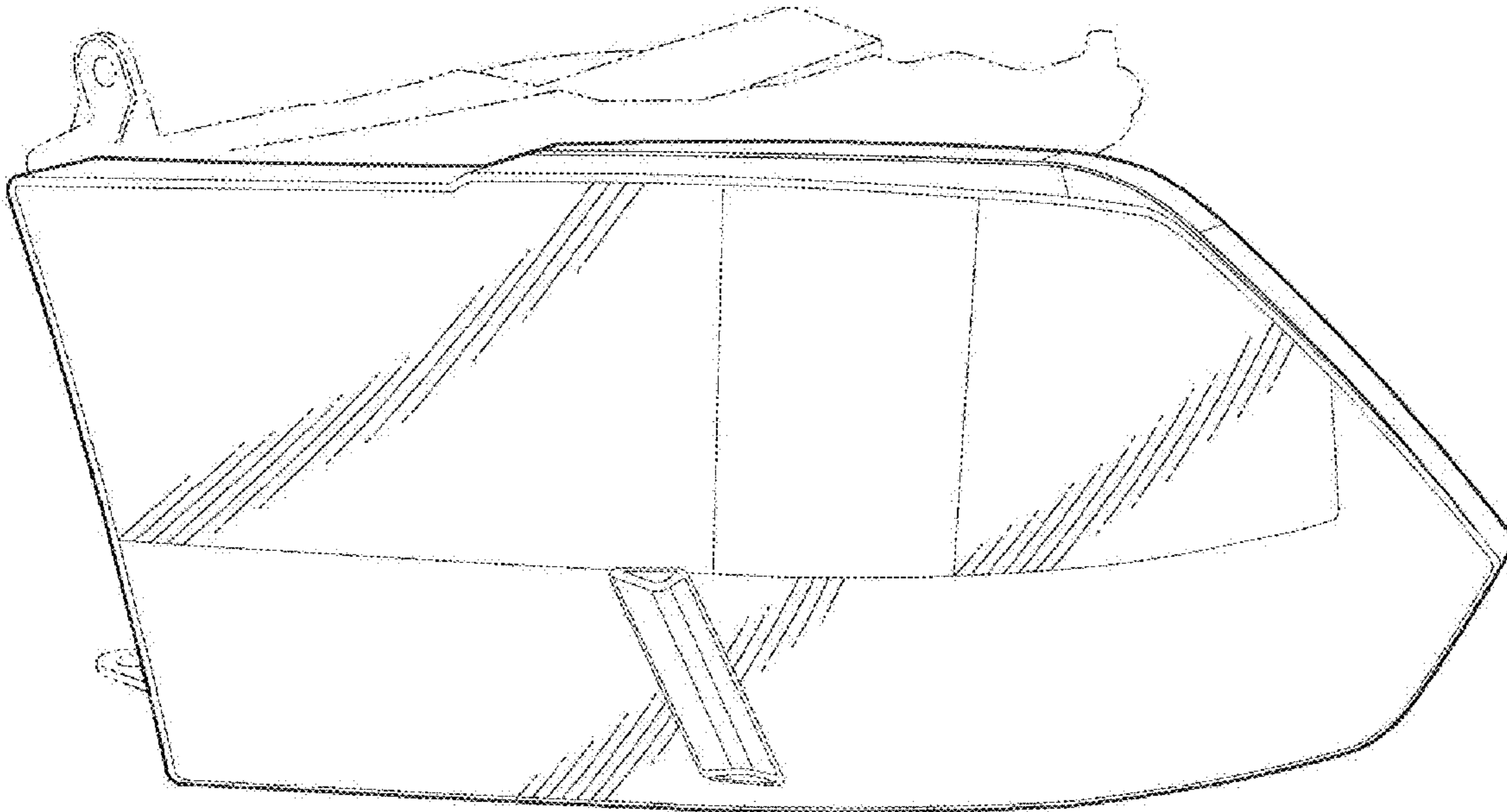

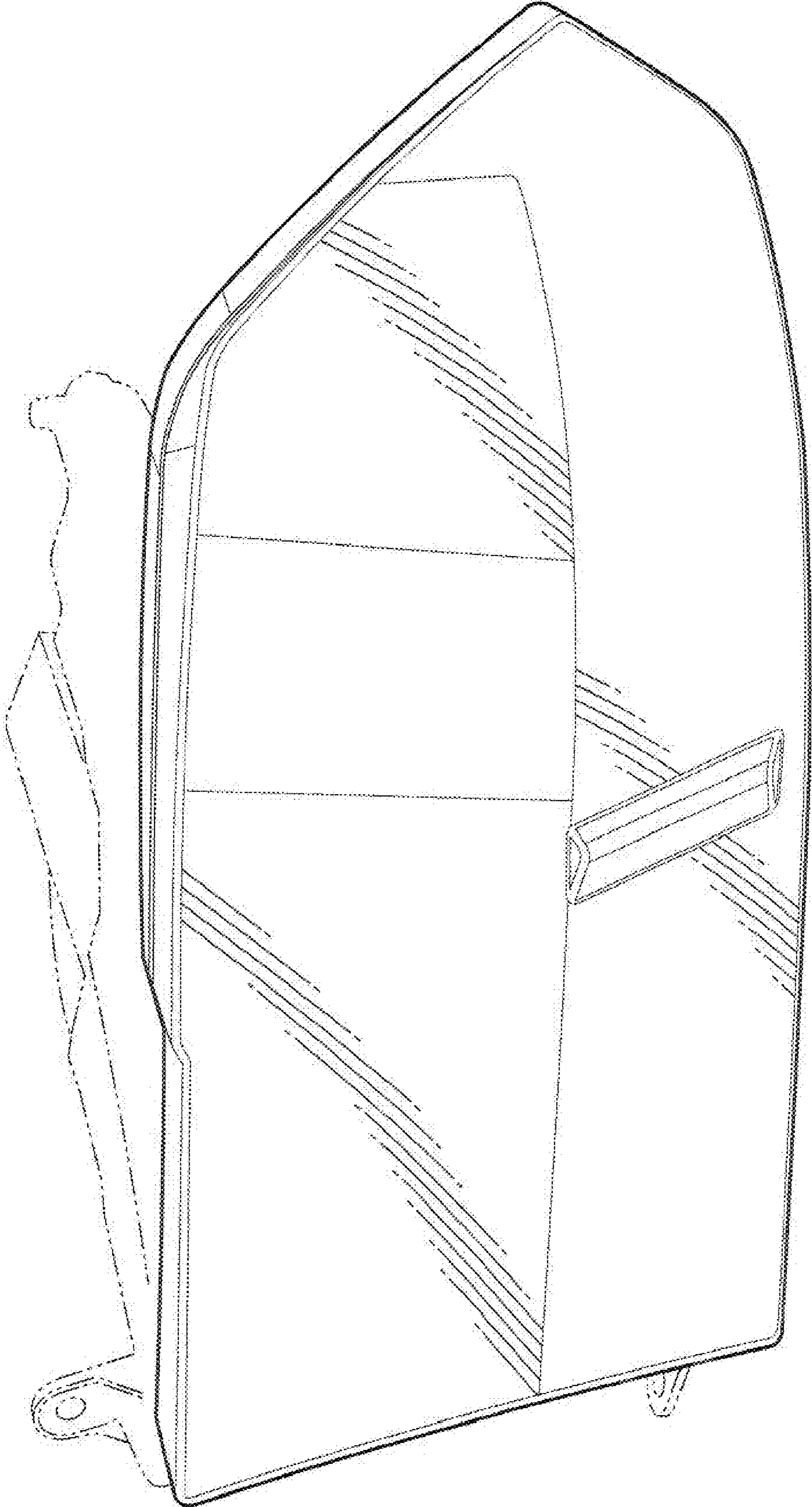

FIG. 1

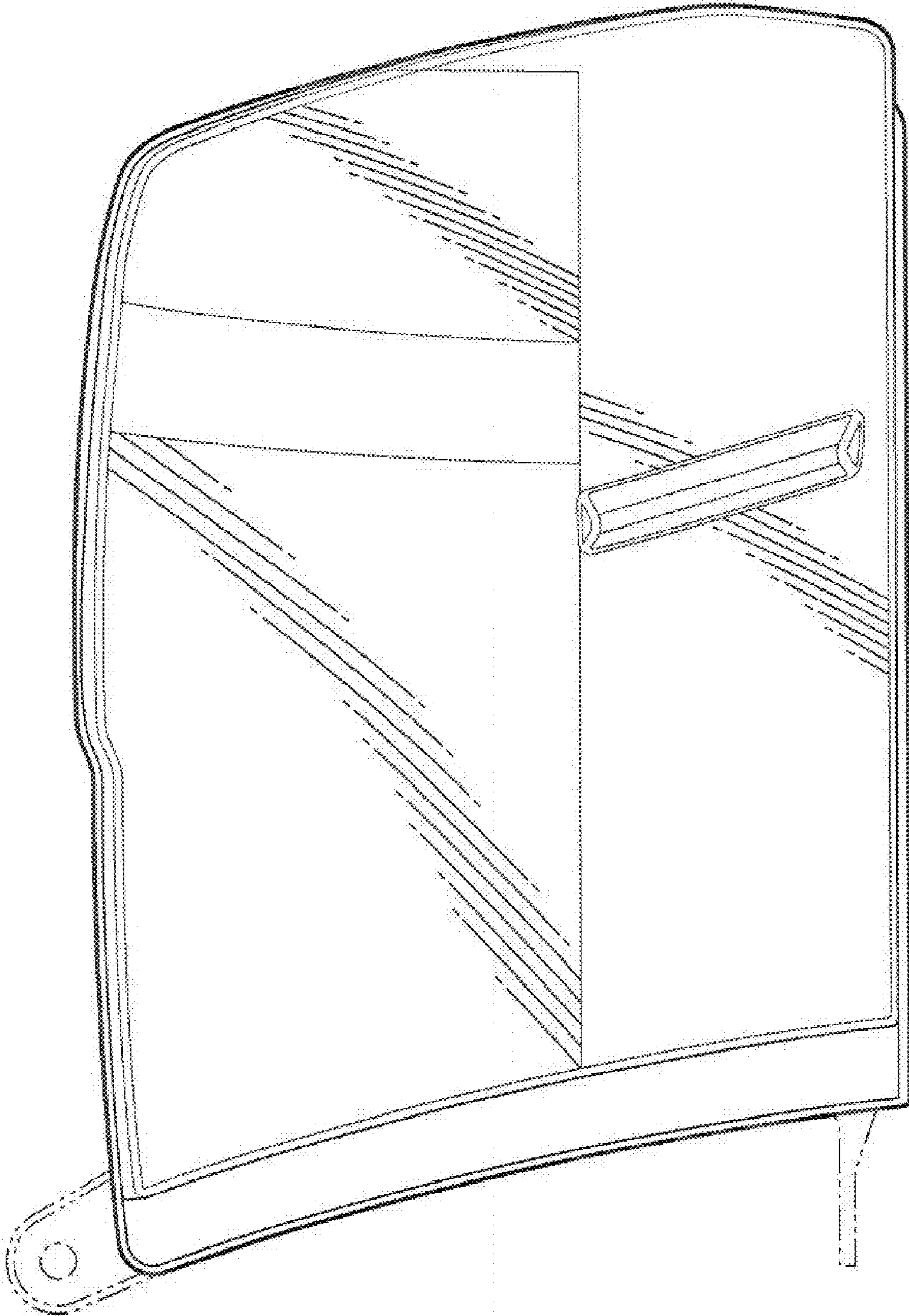

FIG. 2

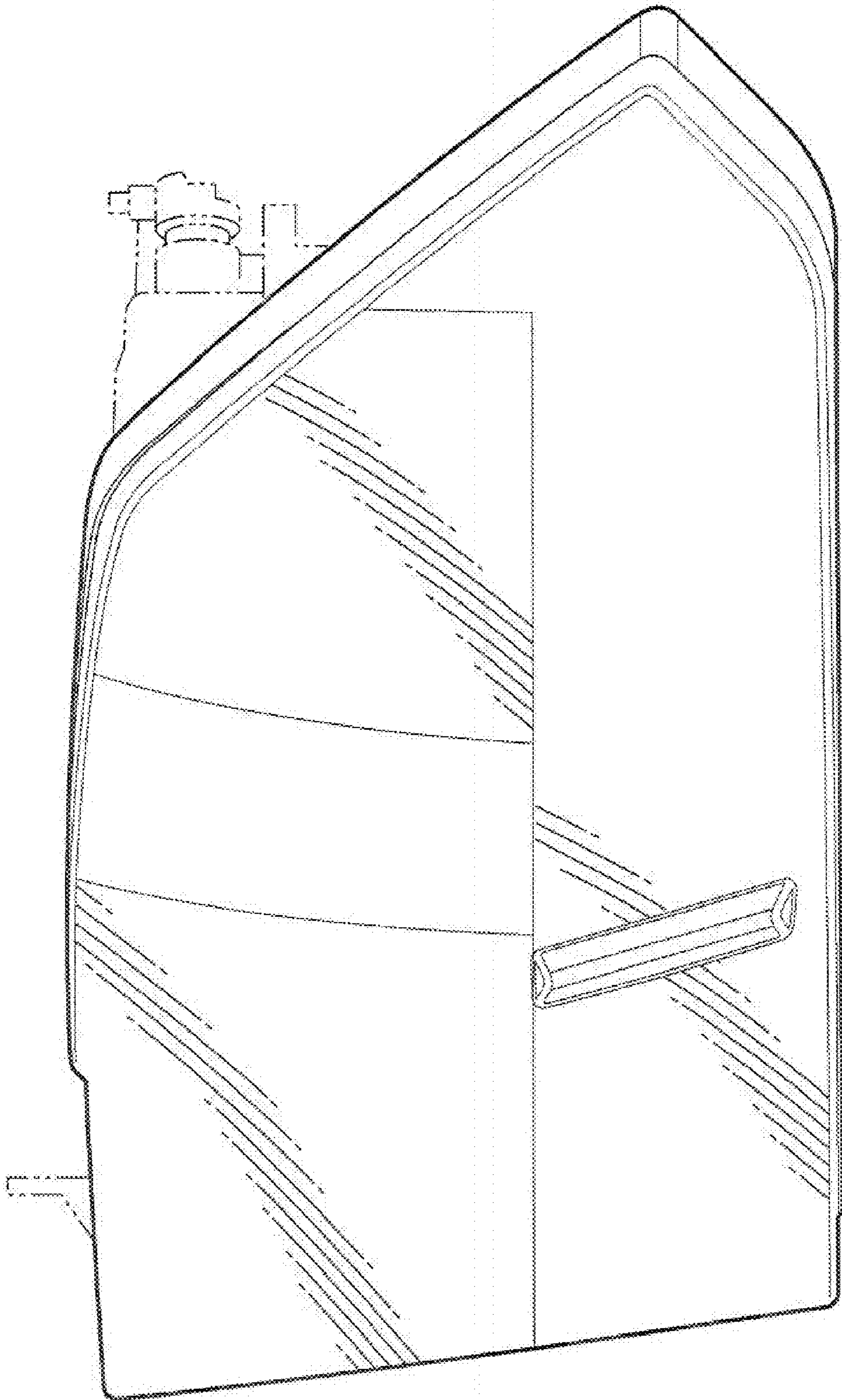

FIG. 3

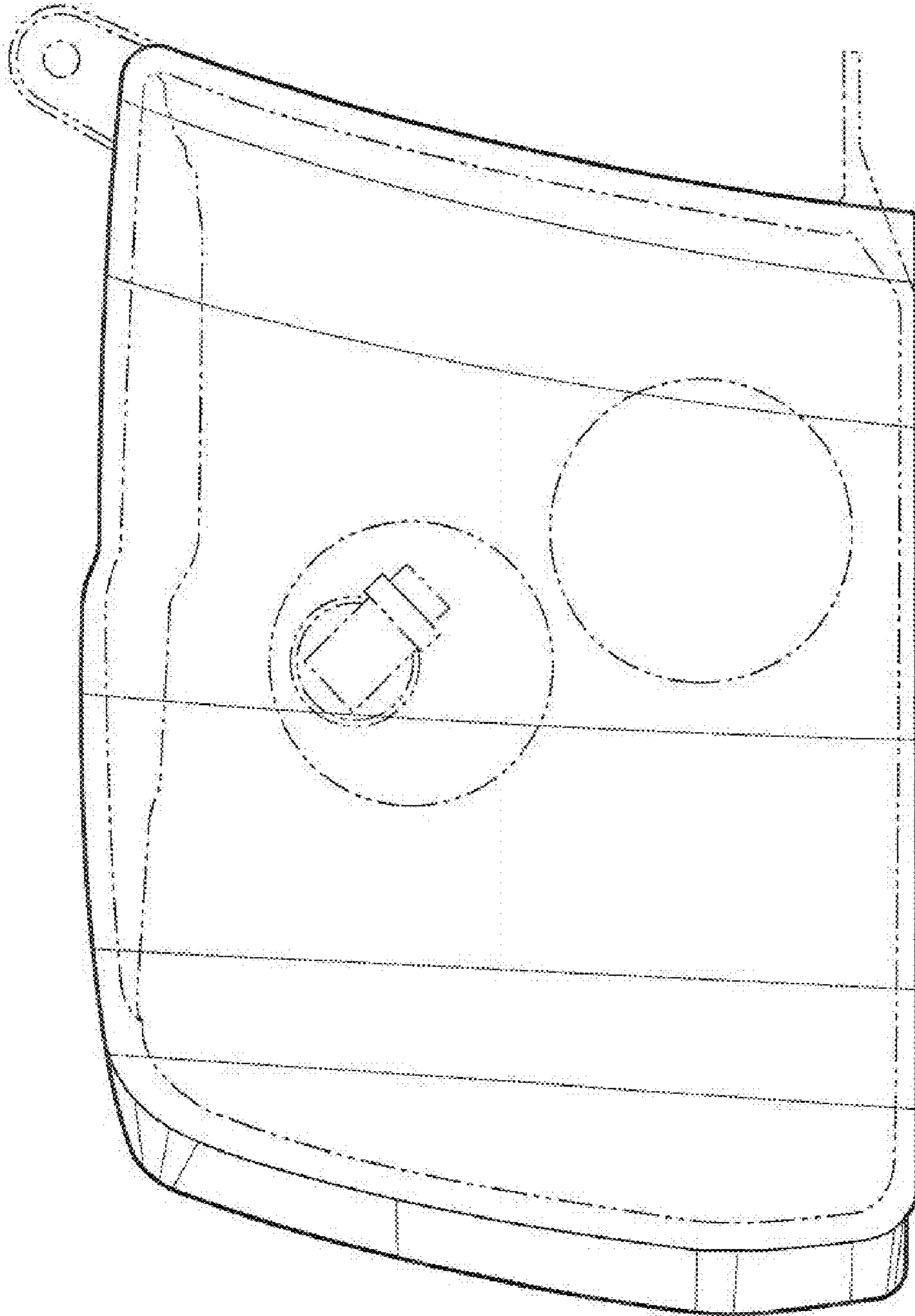

FIG. 4

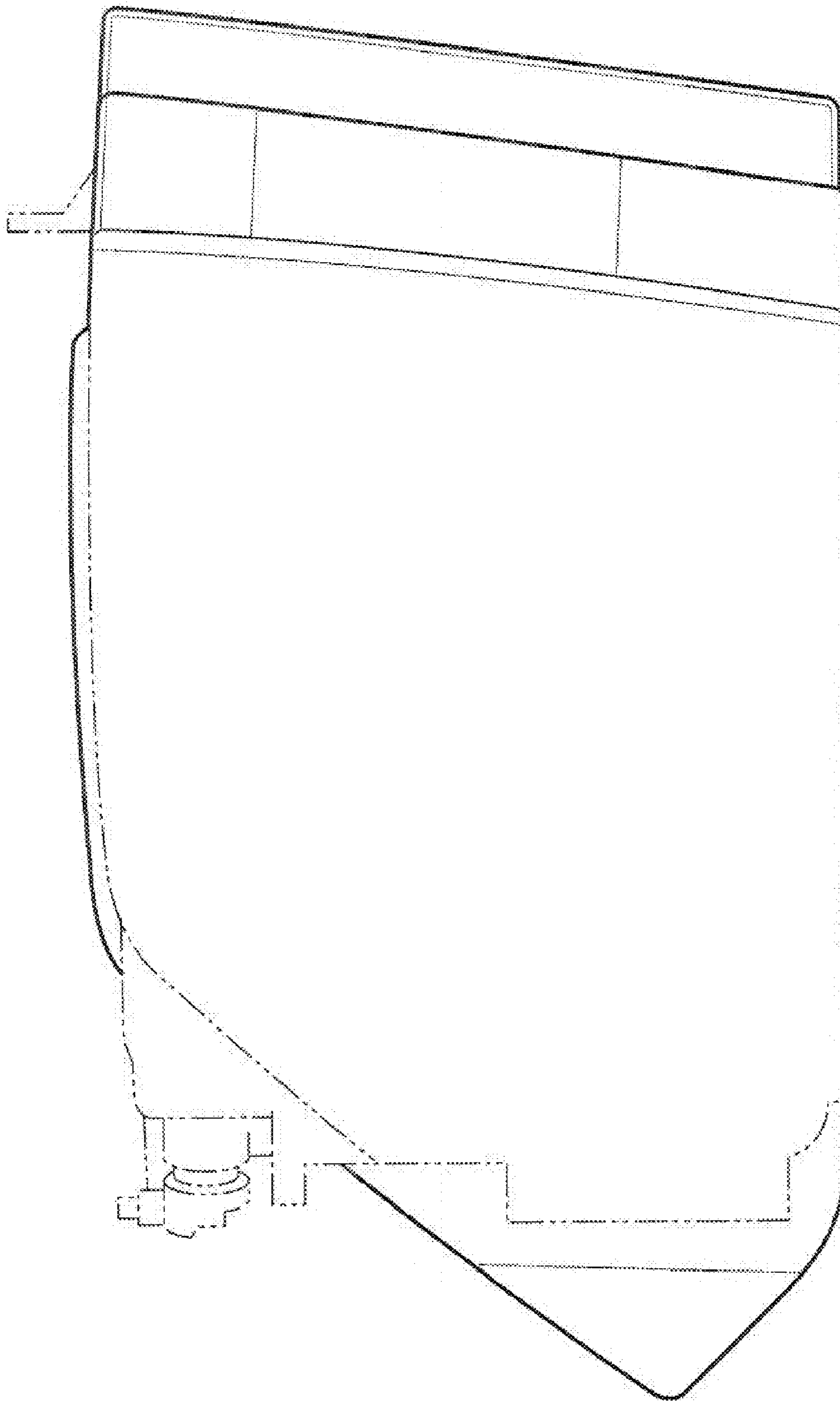

FIG. 5

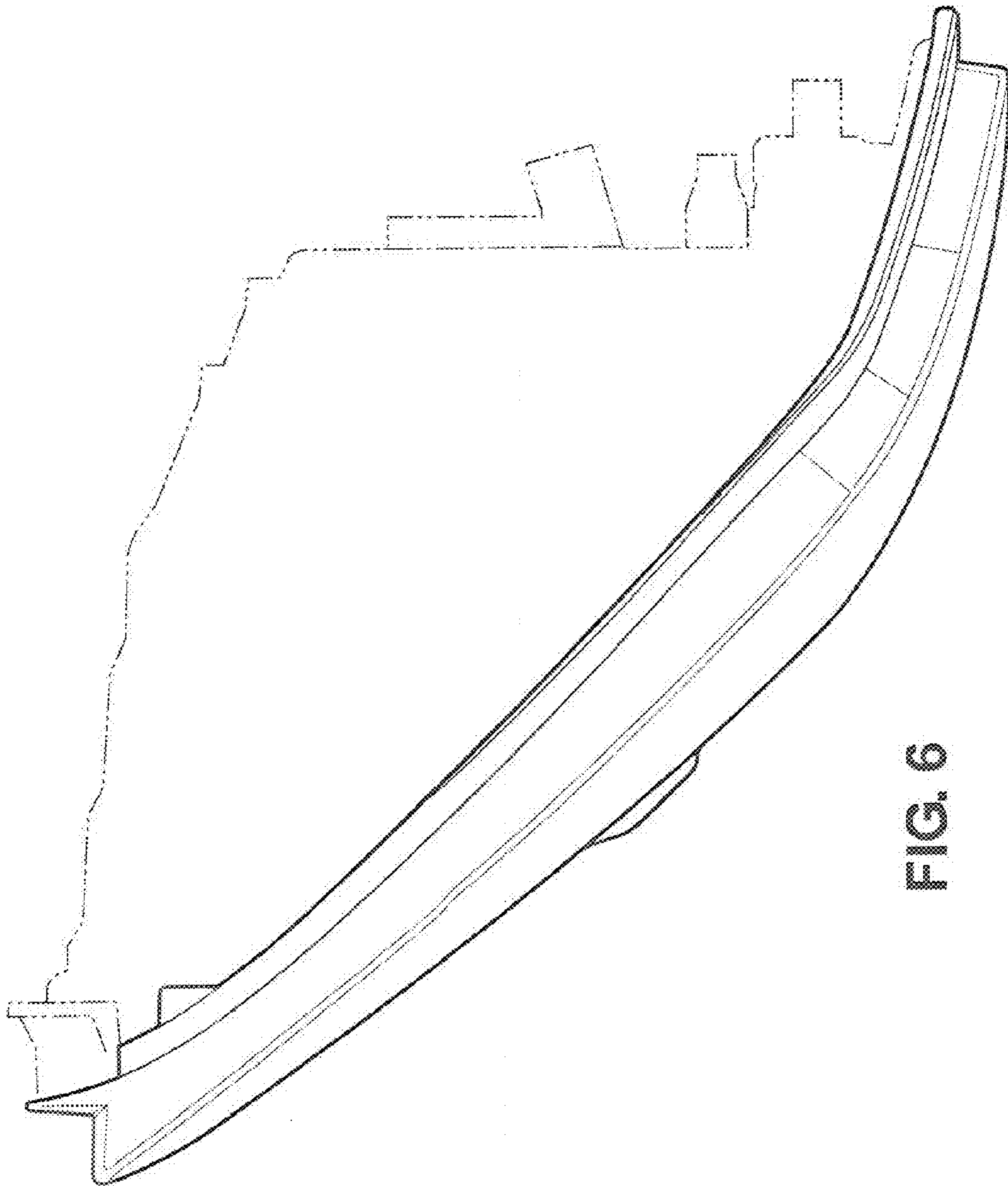

FIG. 6

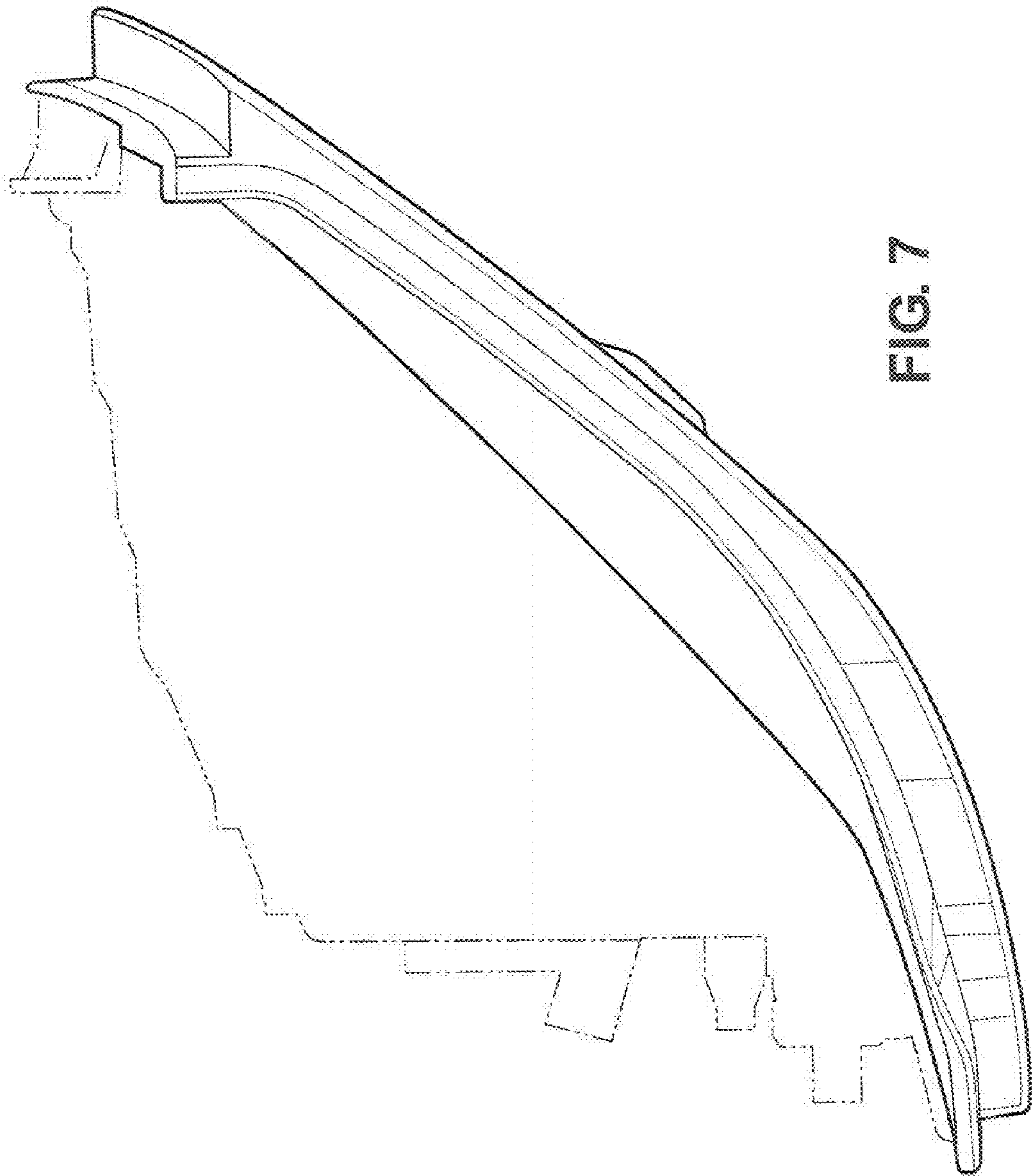

FIG. 7