



US00D641318S

(12) **United States Design Patent**
Maeda

(10) **Patent No.:** **US D641,318 S**

(45) **Date of Patent:** **** Jul. 12, 2011**

(54) **ENGINE GENERATOR**

(75) Inventor: **Joji Maeda**, Wako (JP)

(73) Assignee: **Honda Motor Co., Ltd.**, Tokyo (JP)

(**) Term: **14 Years**

(21) Appl. No.: **29/356,351**

(22) Filed: **Feb. 24, 2010**

(30) **Foreign Application Priority Data**

Aug. 25, 2009 (JP) 2009-019395

(51) **LOC (9) Cl.** **D13/116**

(52) **U.S. Cl.** **D13/116**

(58) **Field of Classification Search** D13/116,
D13/112, 114, 122, 184, 199; 290/1 A, 1 B;
307/150, 151, 153, 154; 322/1, 10, 11, 12,
322/13

See application file for complete search history.

(56) **References Cited**

U.S. PATENT DOCUMENTS

D277,954 S *	3/1985	Mizushima	D13/114
D314,743 S *	2/1991	Ishii	D13/116
5,424,588 A *	6/1995	Cantor et al.	307/154
D437,581 S *	2/2001	Aruga et al.	D13/116
D437,825 S *	2/2001	Imai	D13/116
D477,569 S *	7/2003	Iwatate et al.	D13/116
D478,043 S *	8/2003	Iwatate et al.	D13/116
D572,658 S *	7/2008	Yamamoto et al.	D13/116
2004/0021320 A1 *	2/2004	Yamada et al.	290/1 B

* cited by examiner

Primary Examiner — Stella Reid

Assistant Examiner — Derrick Holland

(74) *Attorney, Agent, or Firm* — Birch, Stewart, Kolasch & Birch, LLP

(57) **CLAIM**

The ornamental design for an engine generator, as shown and described.

DESCRIPTION

FIG. 1 is a perspective view from the front side of an engine generator.

FIG. 2 is a perspective view from the rear side thereof.

FIG. 3 is a front elevation view thereof.

FIG. 4 is a rear elevation view thereof.

FIG. 5 is a left side elevation view thereof.

FIG. 6 is a right side elevation view thereof.

FIG. 7 is a top plan view thereof.

FIG. 8 is a bottom plan view thereof.

FIG. 9 is a reduced perspective view from the front side thereof with the handle unfolded.

FIG. 10 is a reduced front elevation view thereof with the handle unfolded.

FIG. 11 is a reduced left side elevation view thereof with the handle unfolded; and,

FIG. 12 is a reduced right side elevation view thereof with the handle unfolded.

The broken lines shown are for illustrative purposes only and form no part of the claimed design. Where broken lines are used to show environment and the broken lines cross over a full line showing of the claimed design the surface beneath the broken lines is part of the claimed design. Where a broken line is used as a boundary, the area within the broken lines is not part of the claimed design.

1 Claim, 12 Drawing Sheets

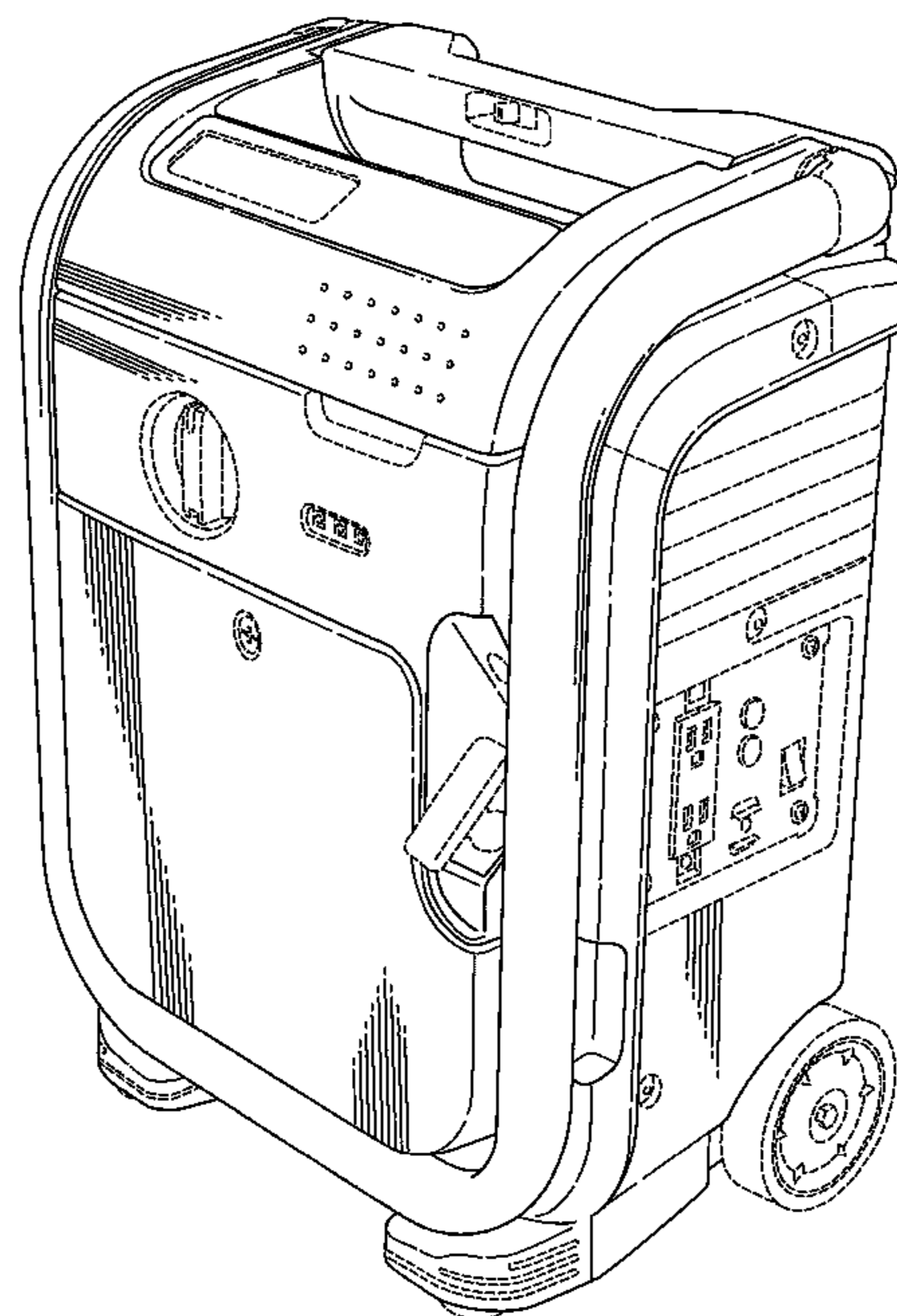

FIG. 1

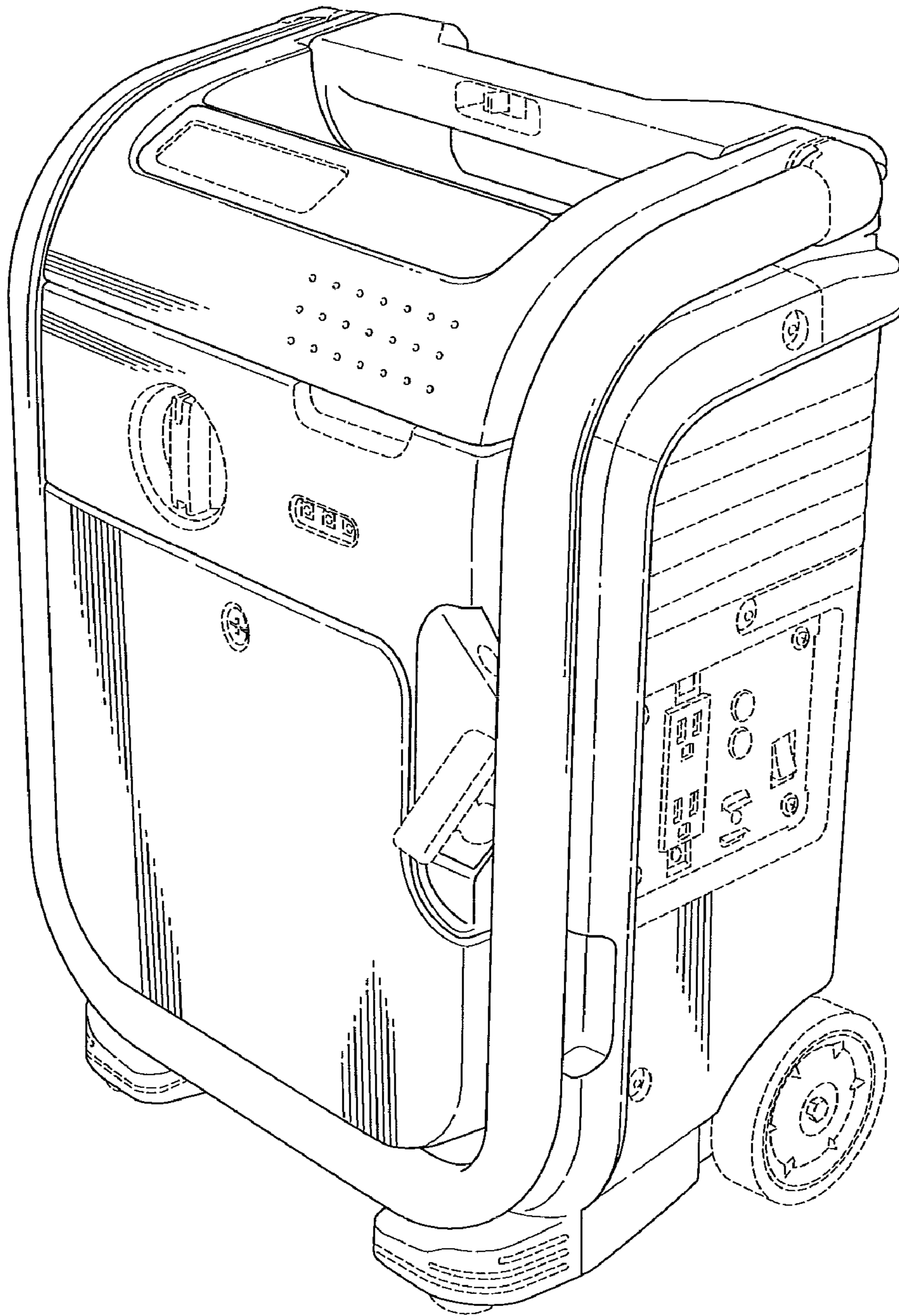

FIG.2

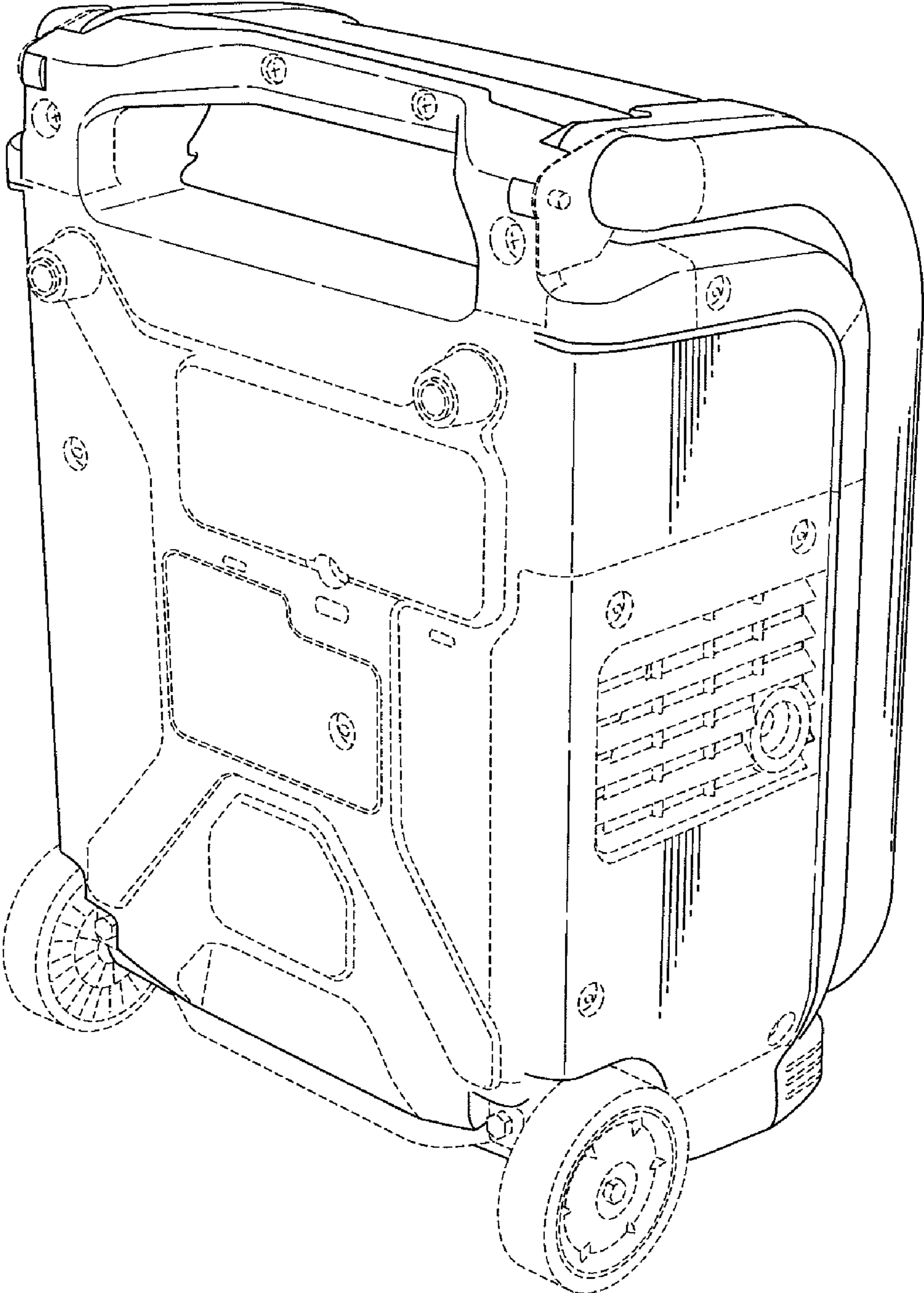

FIG.3

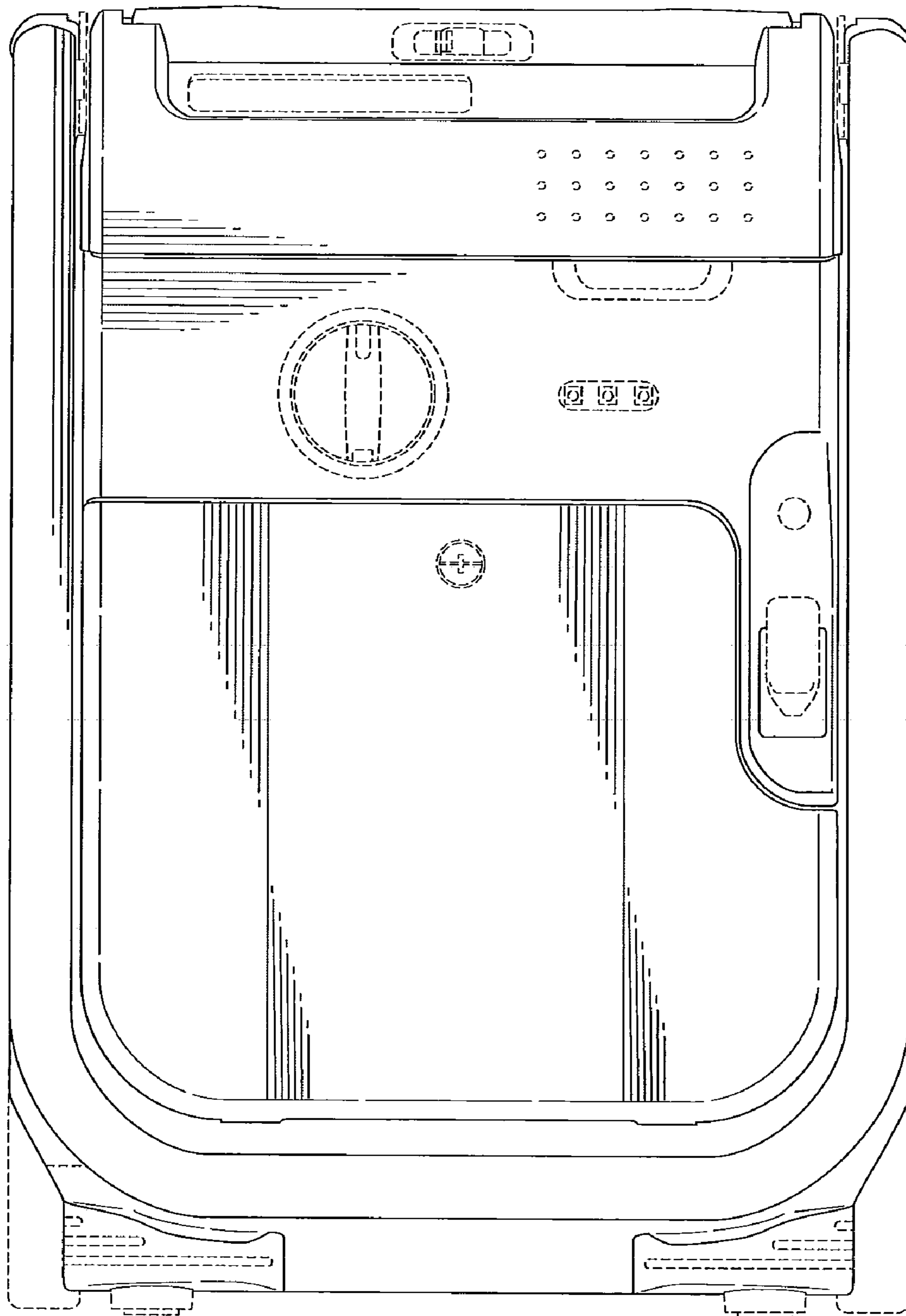

FIG.4

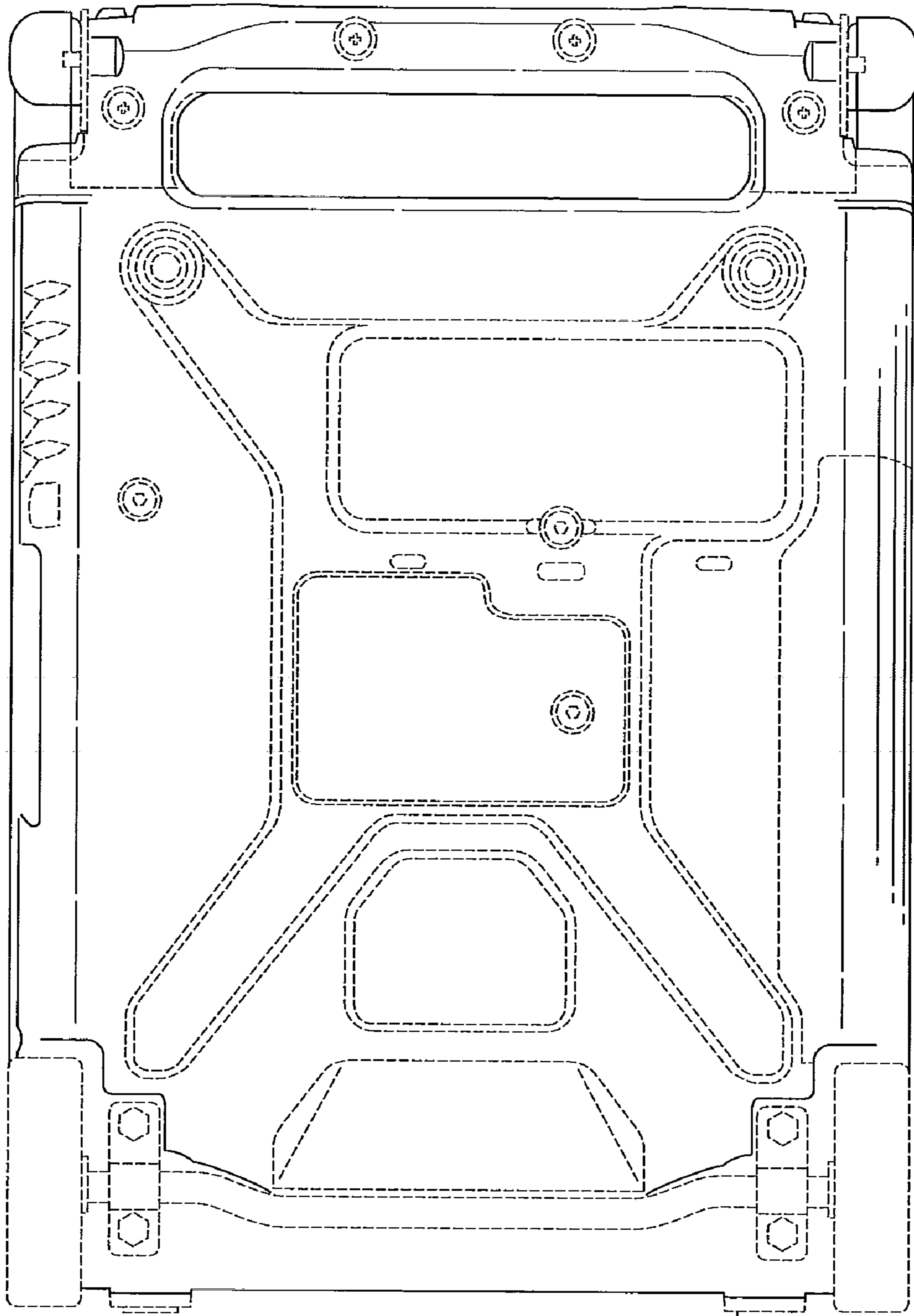

FIG.5

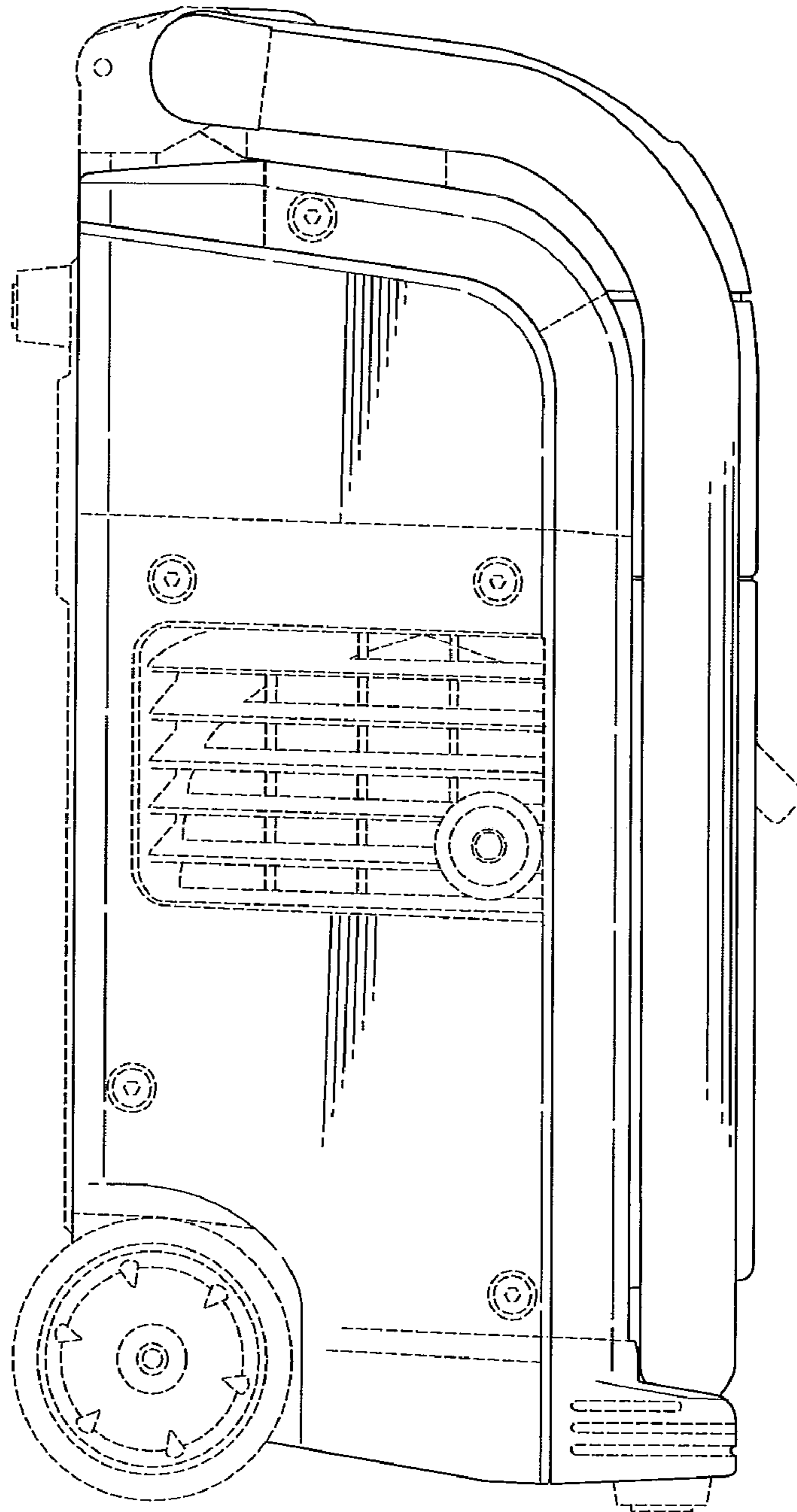

FIG.6

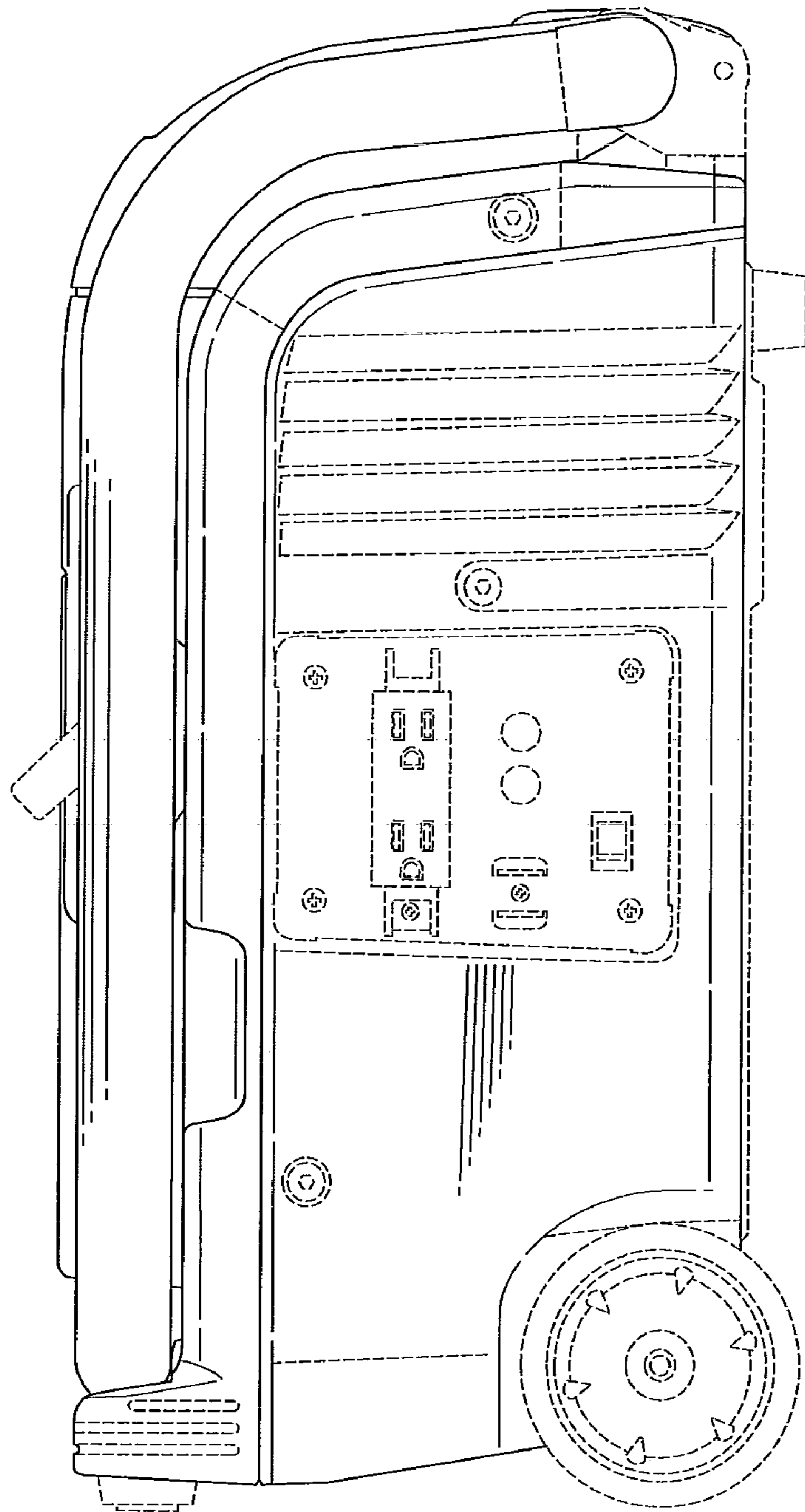

FIG. 7

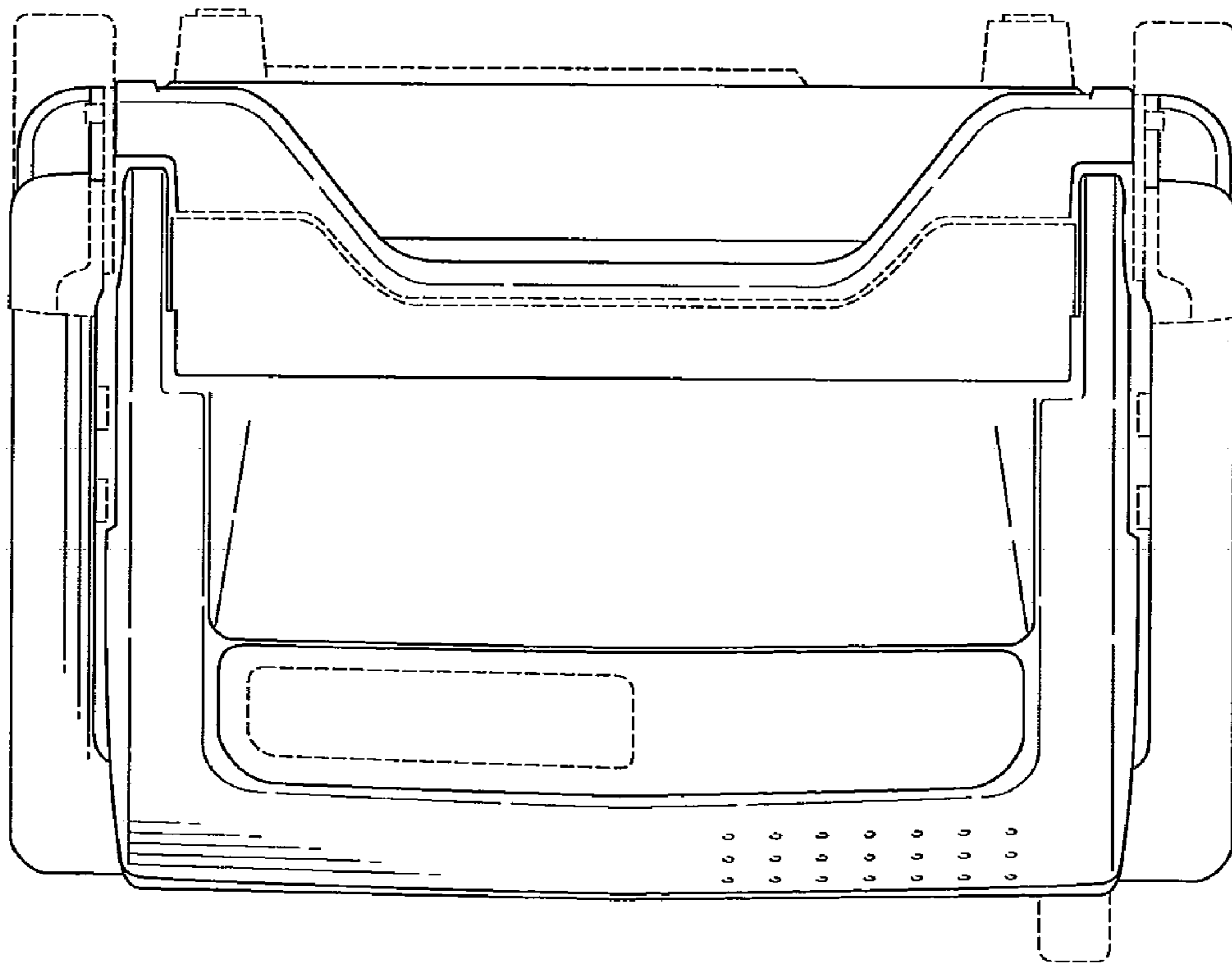

FIG.8

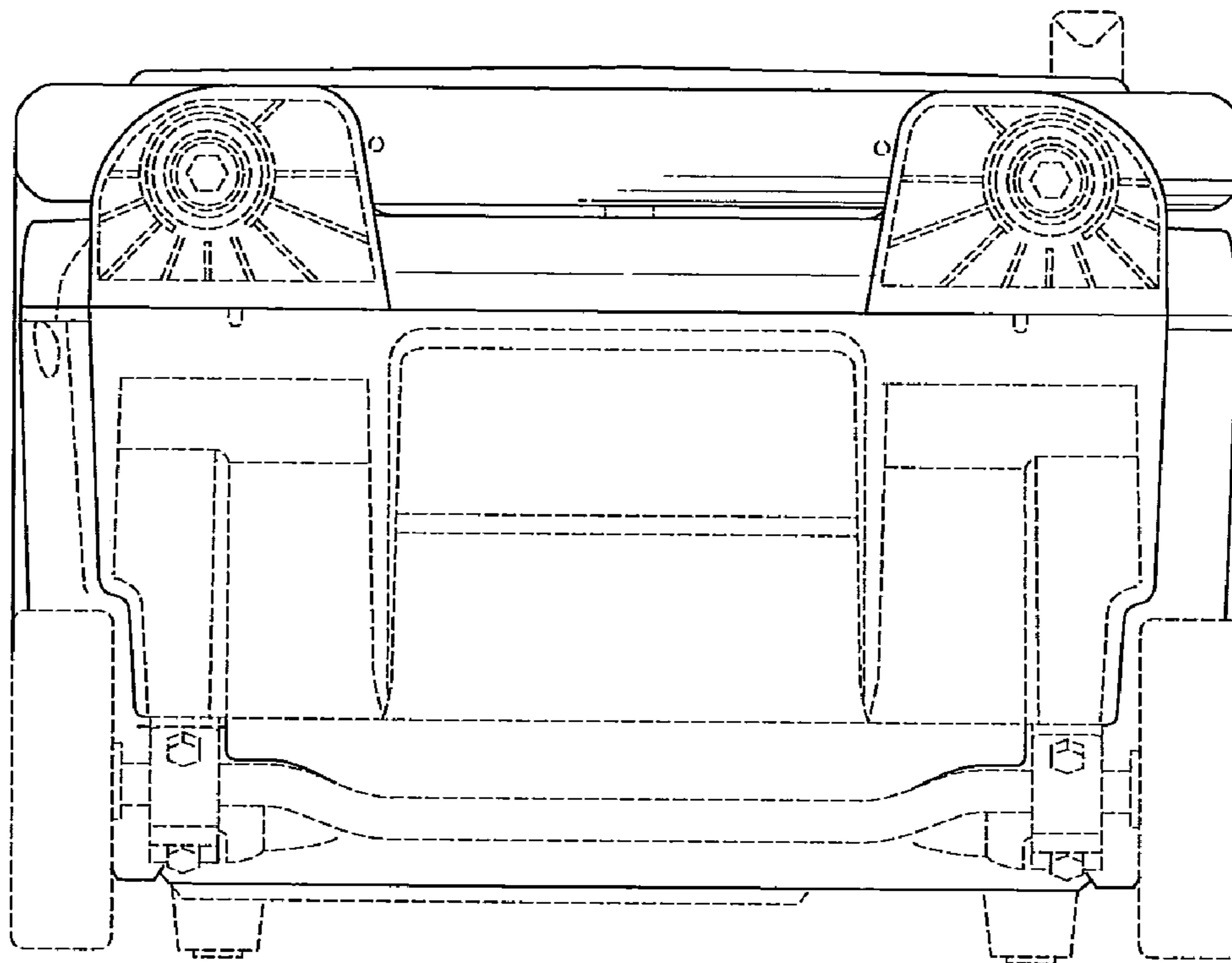

FIG.9

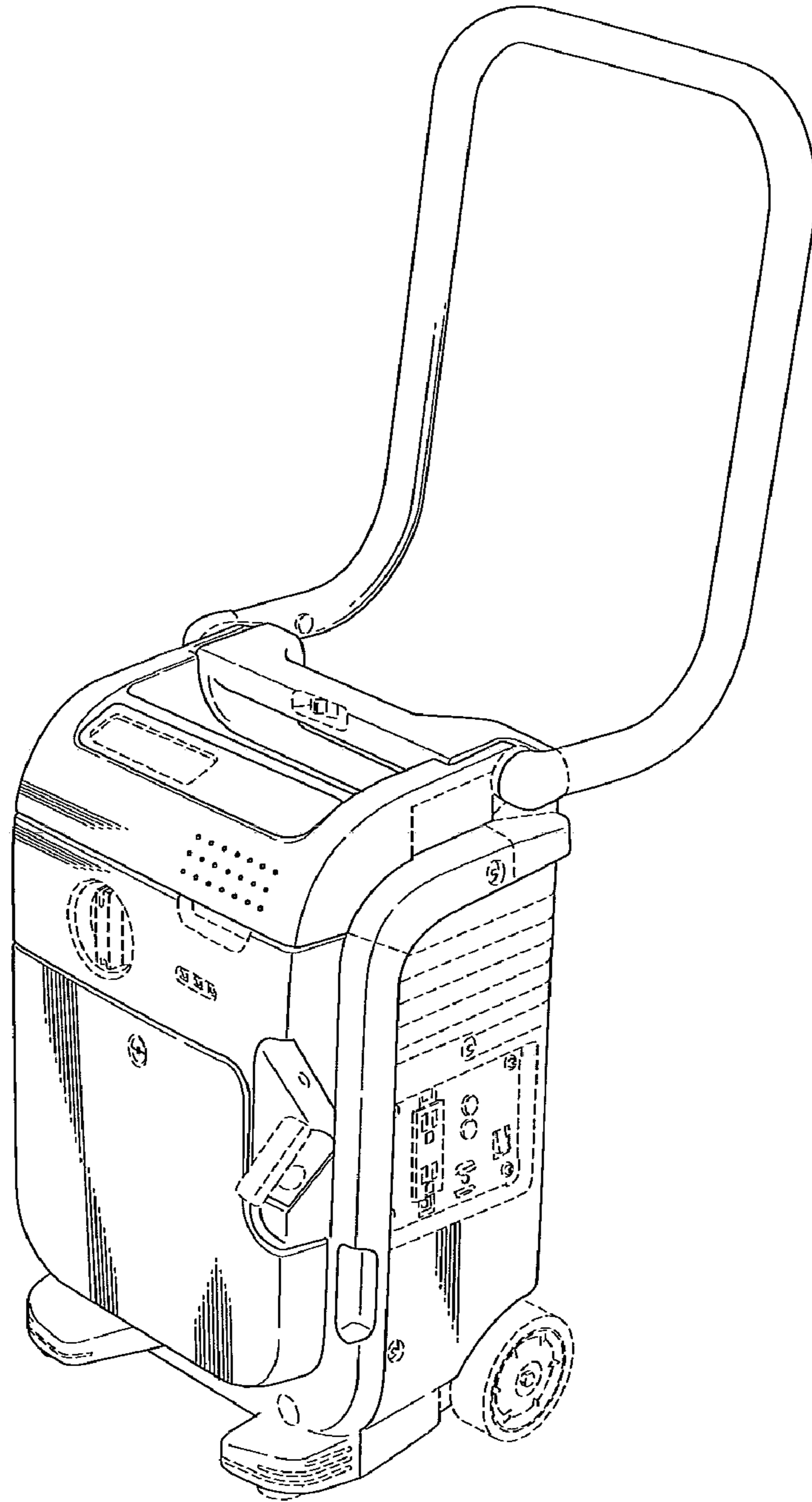

FIG. 10

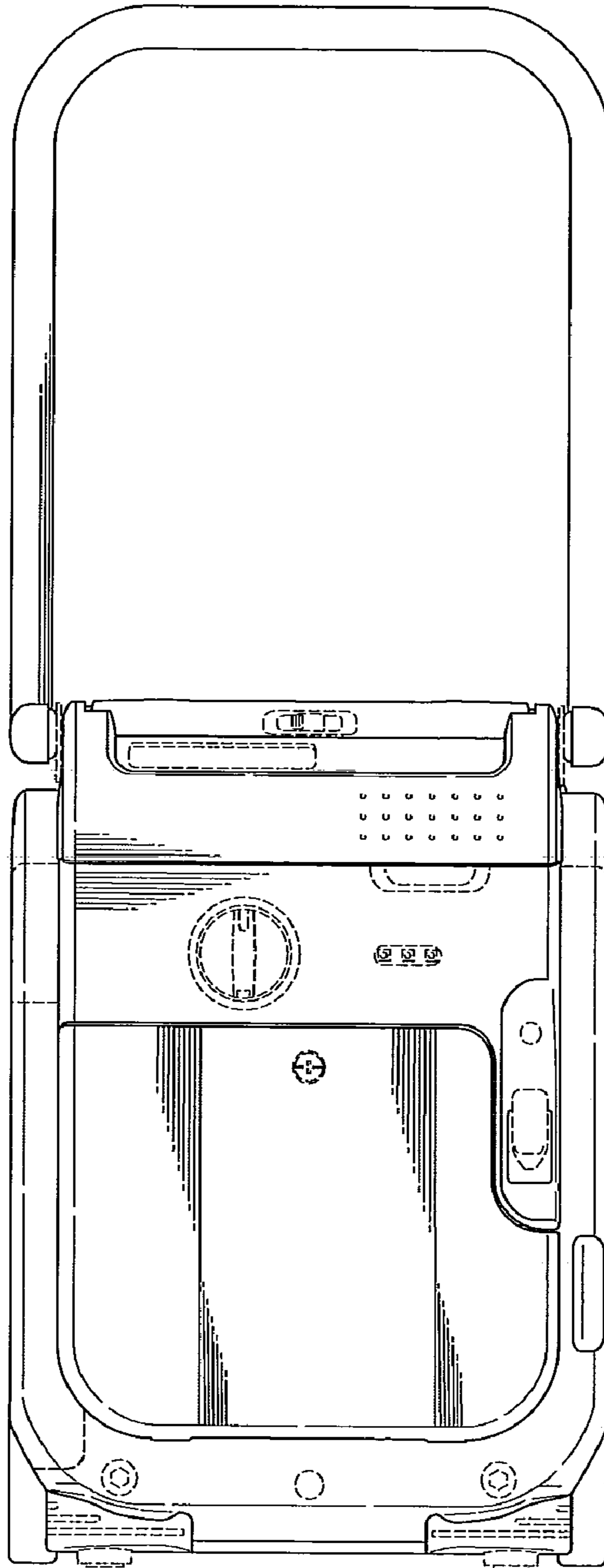

FIG.11

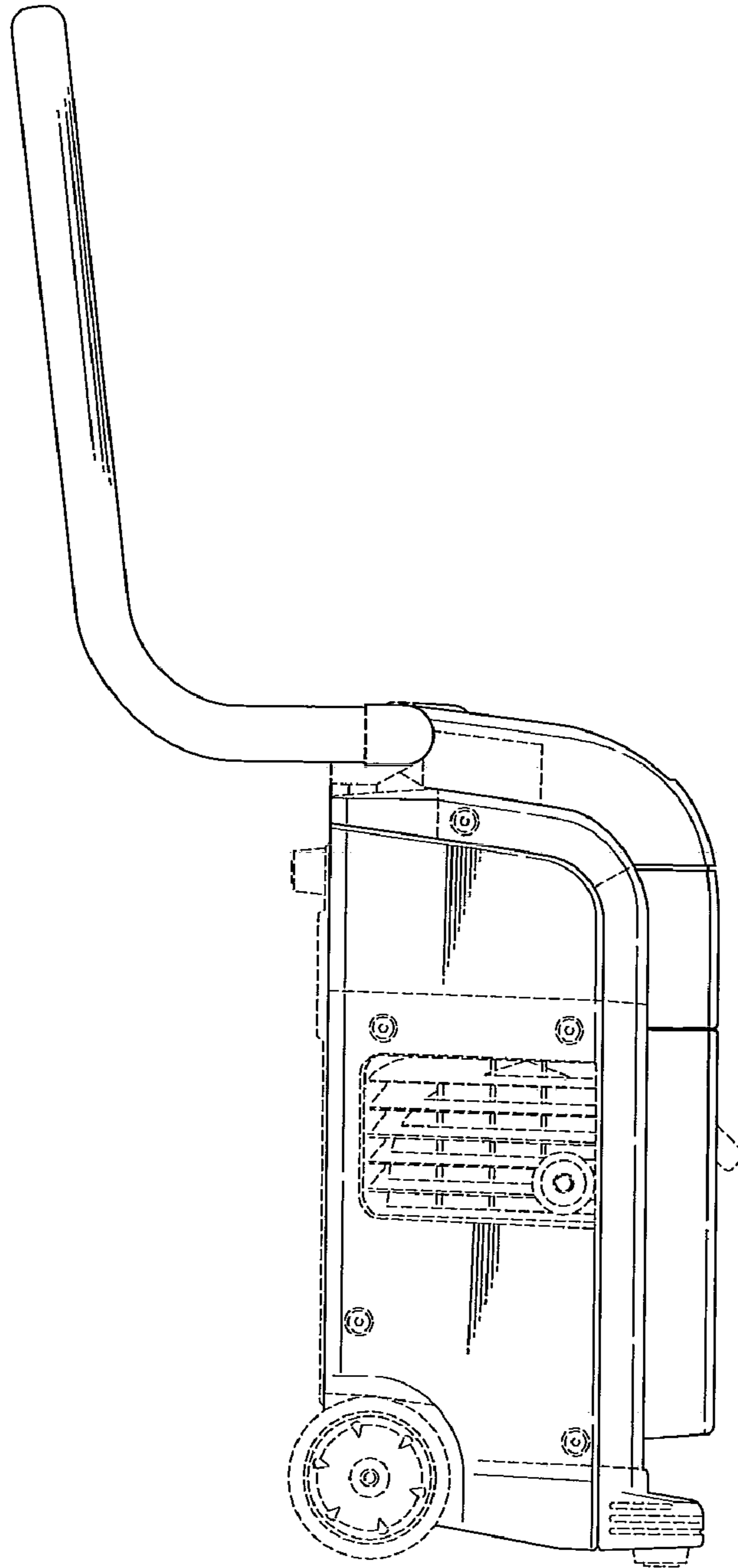

FIG. 12

