



US00D641292S

(12) **United States Design Patent**
Tortola

(10) **Patent No.:** **US D641,292 S**
(45) **Date of Patent:** **** Jul. 12, 2011**

(54) **BICYCLE FRAME**

(76) Inventor: **Lucio Tortola**, Windsor (CA)

(**) Term: **14 Years**

(21) Appl. No.: **29/379,939**

(22) Filed: **Nov. 29, 2010**

D211,225 S	5/1968	Voytech	
3,794,351 A	2/1974	Cudmore	
D239,009 S	3/1976	Yokahama et al.	
4,015,854 A *	4/1977	Ramond	280/281.1
4,453,730 A *	6/1984	Klose	280/281.1
D343,598 S *	1/1994	Southwell et al.	D12/111
D478,299 S	8/2003	Hartman	
D542,717 S	5/2007	Stumm et al.	
7,377,534 B2 *	5/2008	Ellsworth	280/281.1
D612,300 S	3/2010	Lobnitz	
D626,037 S	10/2010	Thetard	
2007/0145710 A1	6/2007	Stumm et al.	

* cited by examiner

(30) **Foreign Application Priority Data**

Nov. 21, 2010 (WO) 574148301

(51) **LOC (9) Cl.** **12-11**

(52) **U.S. Cl.** **D12/111**

(58) **Field of Classification Search** D12/111,
D12/117, 119; 280/274-280, 281.1, 283-288,
280/288.3

See application file for complete search history.

Primary Examiner — Susan M Lee

Assistant Examiner — Linda Brooks

(74) *Attorney, Agent, or Firm* — Perry + Currier

(57) **CLAIM**

The ornamental design for a bicycle frame, as shown and described.

DESCRIPTION

FIG. 1 is a right side perspective view of a bicycle frame, the left side being a mirror image of the right side view.

FIG. 2 is a view of the bicycle frame shown in position of use, with the broken line illustration of other portions of a bicycle and environment forming no part of the claimed design.

FIG. 3 is a top view of the bicycle frame of FIG. 1.

FIG. 4 is a bottom view of the bicycle frame of FIG. 1.

FIG. 5 is a front view of the bicycle frame of FIG. 1; and,

FIG. 6 is a rear view of the bicycle frame of FIG. 1.

The portions shown in broken and/or stippled lines do not form part of the design.

(56) **References Cited**

U.S. PATENT DOCUMENTS

D26,179 S	10/1896	Billings	
D26,263 S	11/1896	Gates	
D26,590 S	2/1897	Harris	
D27,186 S *	6/1897	Busse	D12/111
D27,187 S *	6/1897	Busse	D12/111
D27,767 S	10/1897	Andrews	
D33,144 S *	8/1900	Smithers	D12/111
2,151,533 A	3/1939	Schwinn	
2,330,560 A *	9/1943	Descos	280/274
3,226,132 A	12/1965	Otani	
D208,044 S	7/1967	Voytech	

1 Claim, 4 Drawing Sheets

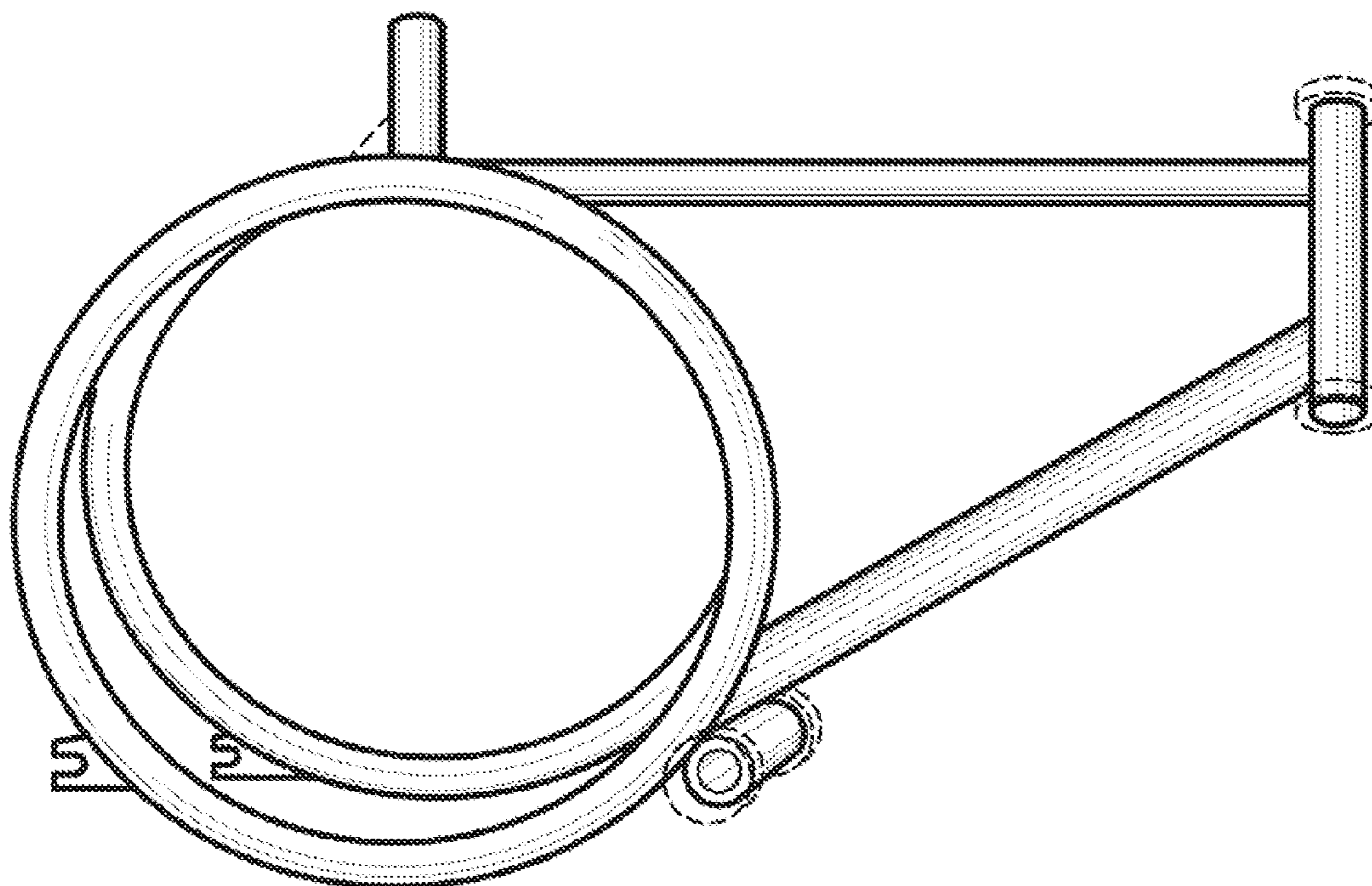

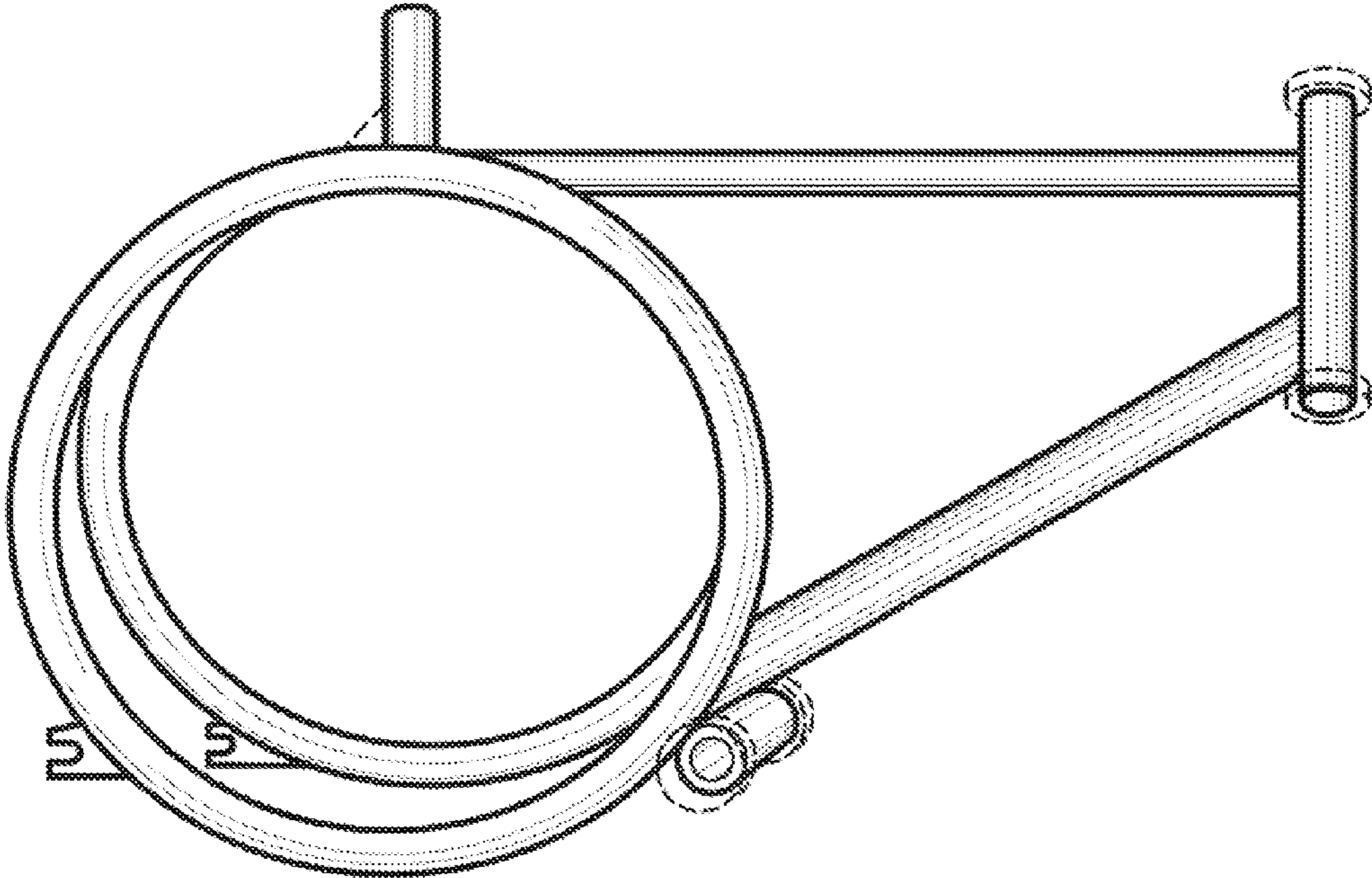

Fig. 1

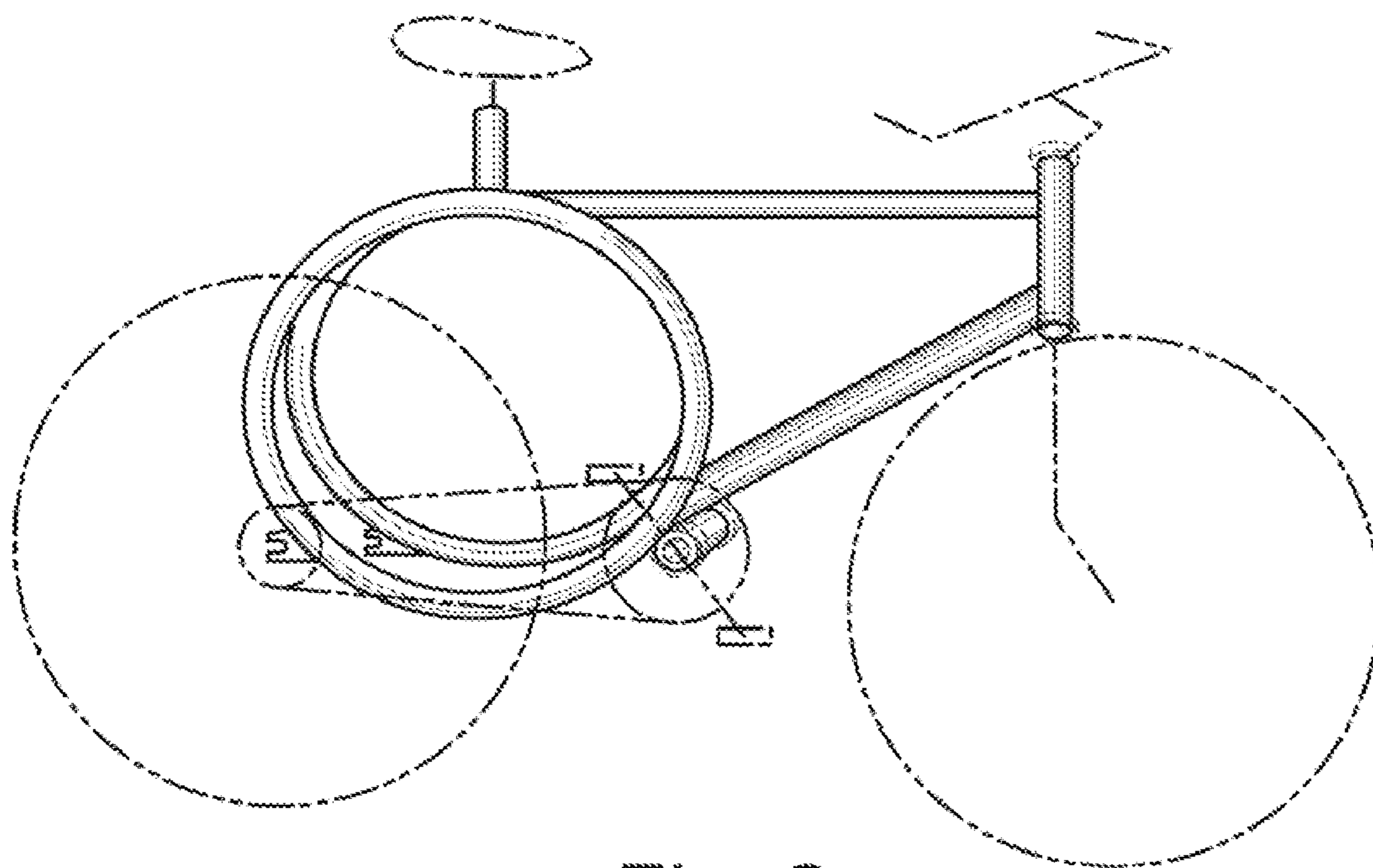

Fig. 2

Fig. 3

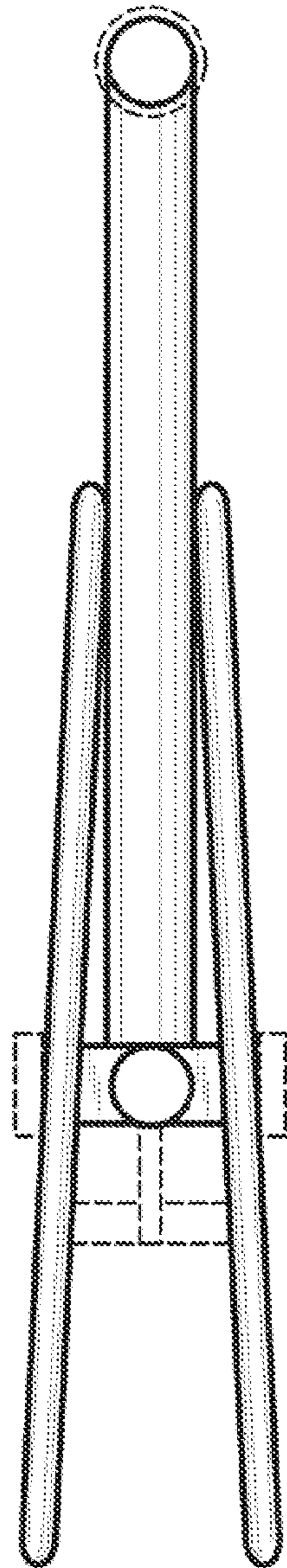

Fig. 4

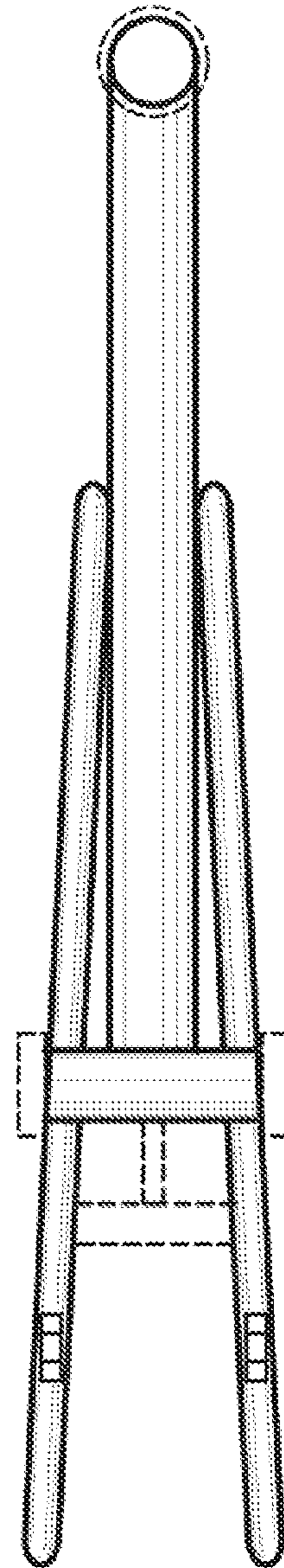

Fig. 5

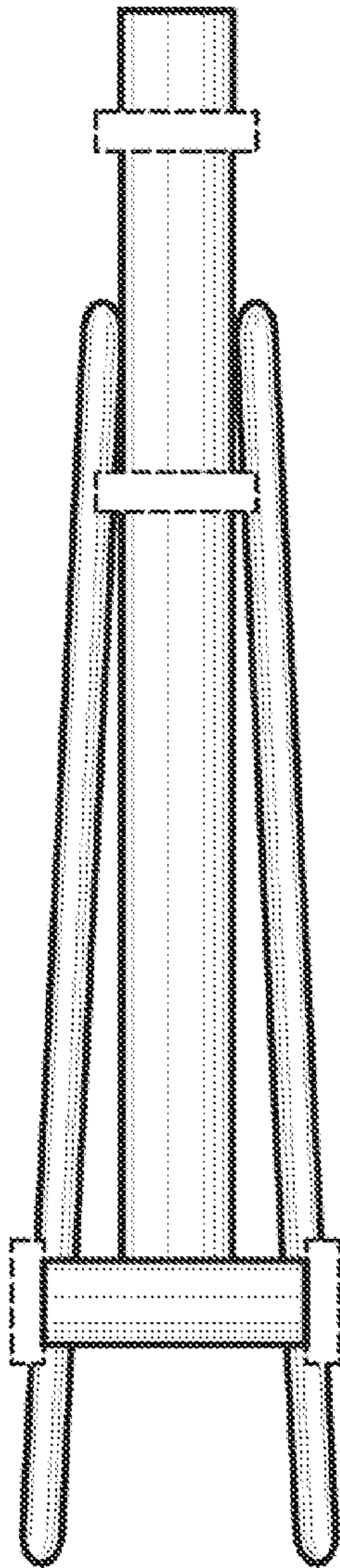

Fig. 6

