



US00D641006S

(12) **United States Design Patent**
Anthony et al.

(10) **Patent No.:** **US D641,006 S**
(45) **Date of Patent:** **** Jul. 5, 2011**

(54) **LOUDSPEAKER**

(75) Inventors: **Philip J. Anthony**, Marlow (GB); **Peter F. Lawrence**, Old Amersham (GB); **Jason D. Baird**, London (GB); **Christopher J. Stokes**, Henley On Thames (GB)

(73) Assignee: **Martin Audio Ltd.** (GB)

(**) Term: **14 Years**

(21) Appl. No.: **29/354,667**

(22) Filed: **Jan. 27, 2010**

(30) **Foreign Application Priority Data**

Jul. 27, 2009 (EM) 1156475-0001

(51) **LOC (9) Cl.** **14-01**

(52) **U.S. Cl.** **D14/214**

(58) **Field of Classification Search** D14/204,
D14/210-215, 172; 181/143-144, 147-148,
181/150-153, 157, 198-199; 381/300-303,
381/306, 332-333, 336, 345, 361-364, 386-388
See application file for complete search history.

(56) **References Cited**

U.S. PATENT DOCUMENTS

D317,919 S * 7/1991 Kawanabe D14/210
D531,986 S * 11/2006 Azumi et al. D14/214
D543,535 S * 5/2007 Hasegawa et al. D14/214
D549,690 S * 8/2007 Kimura D14/211

* cited by examiner

Primary Examiner — Nanda Bondade

(74) *Attorney, Agent, or Firm* — Dinsmore & Shohl LLP

(57) **CLAIM**

The ornamental design for a loudspeaker, as shown and described.

DESCRIPTION

FIG. 1 is a front elevation view of a loudspeaker showing the new design;

FIG. 2 is a front view of the design of FIG. 1;

FIG. 3 is a rear view of the design of FIG. 1;

FIG. 4 is a side view of the design of FIG. 1;

FIG. 5 is an opposite side view of the design of FIG. 1;

FIG. 6 is a top view of the design of FIG. 1;

FIG. 7 is a bottom view of the design of FIG. 1;

FIG. 8 is a front elevation view of another embodiment of a loudspeaker of FIG. 1;

FIG. 9 is a front view of the design of FIG. 8;

FIG. 10 is a rear view of the design of FIG. 8;

FIG. 11 is a side view of the design of FIG. 8;

FIG. 12 is an opposite side view of the design of FIG. 8;

FIG. 13 is a top view of the design of FIG. 8; and,

FIG. 14 is a bottom view of the design of FIG. 8.

The broken lines, if any, represent portions of the structure that form no part of the claim.

1 Claim, 8 Drawing Sheets

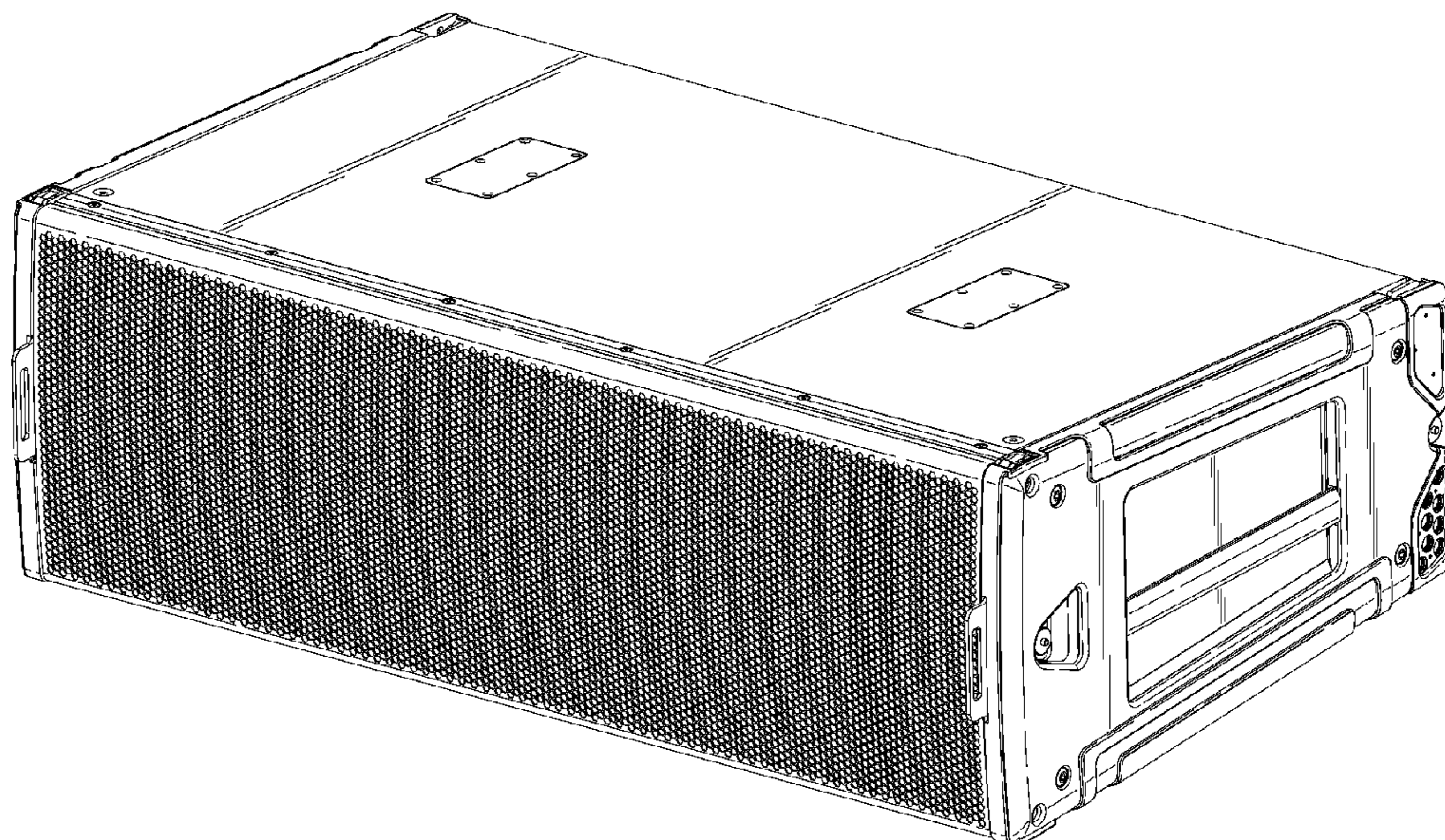

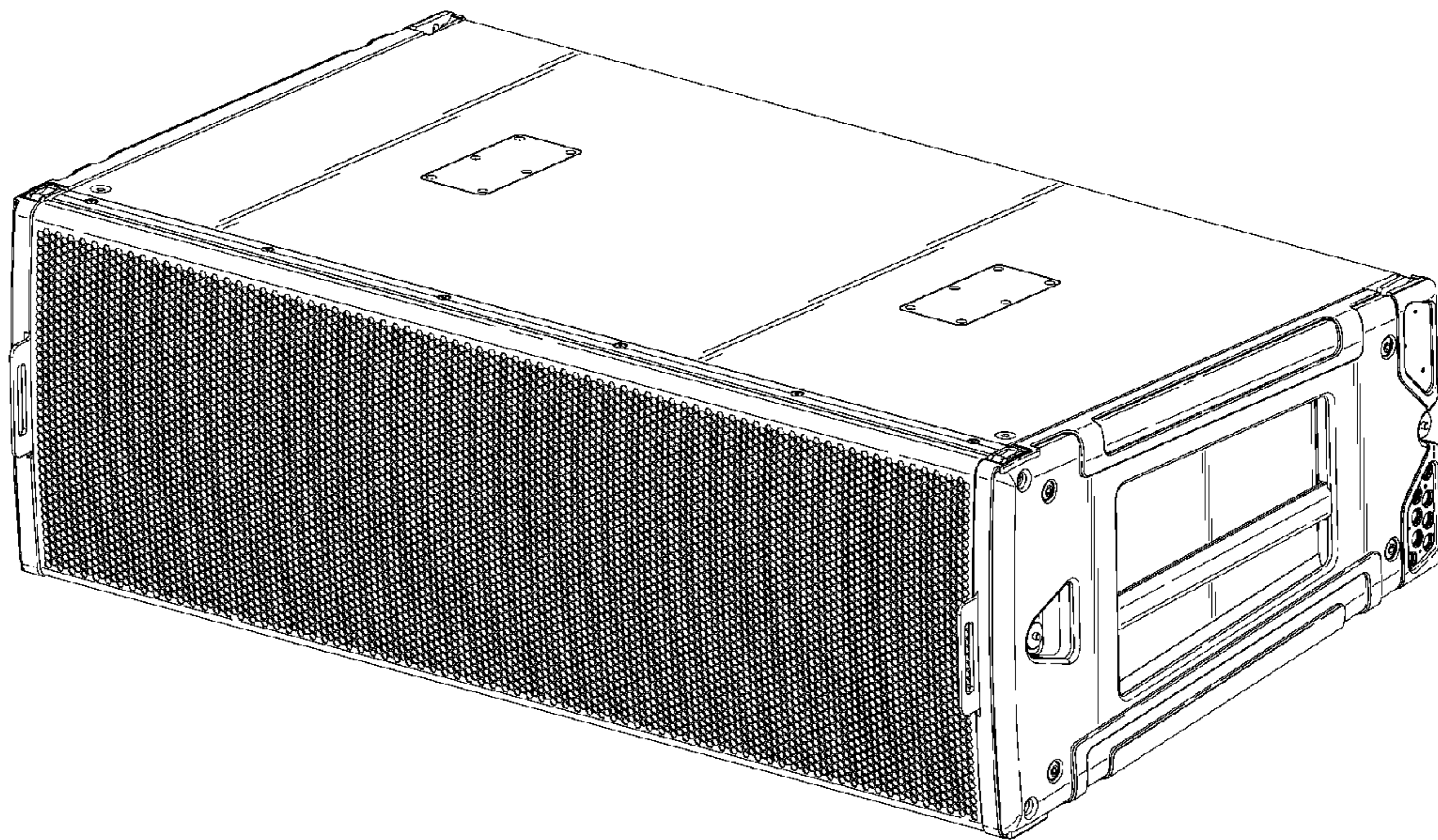

Fig.1.

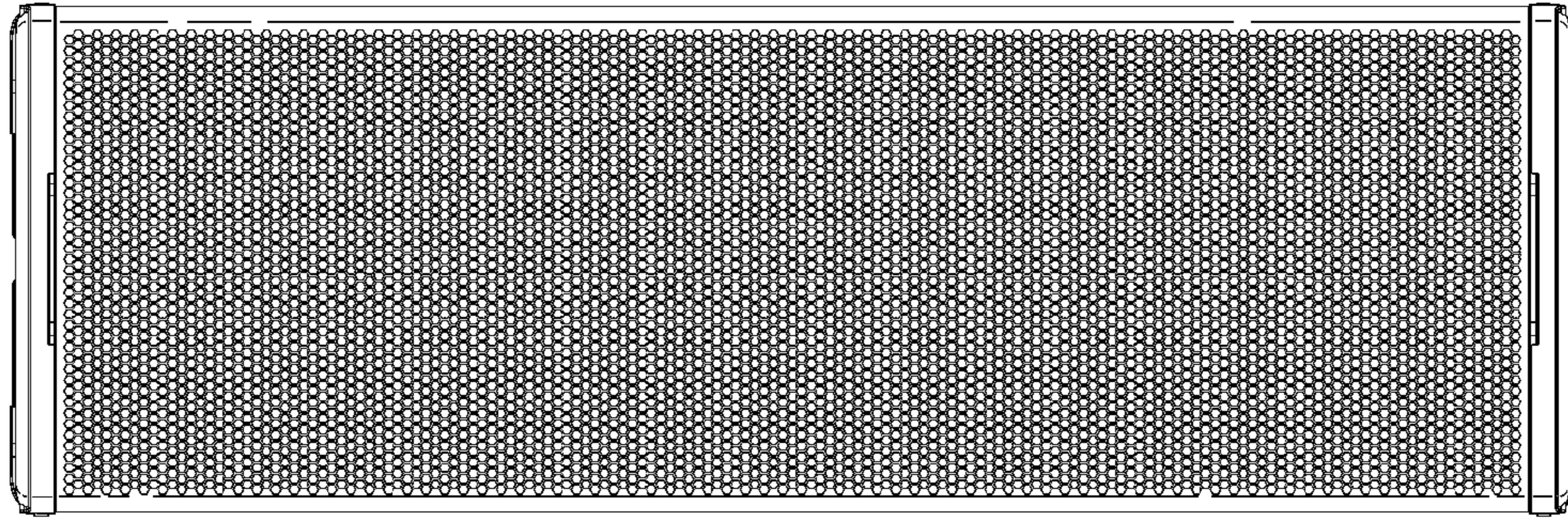

Fig.2.

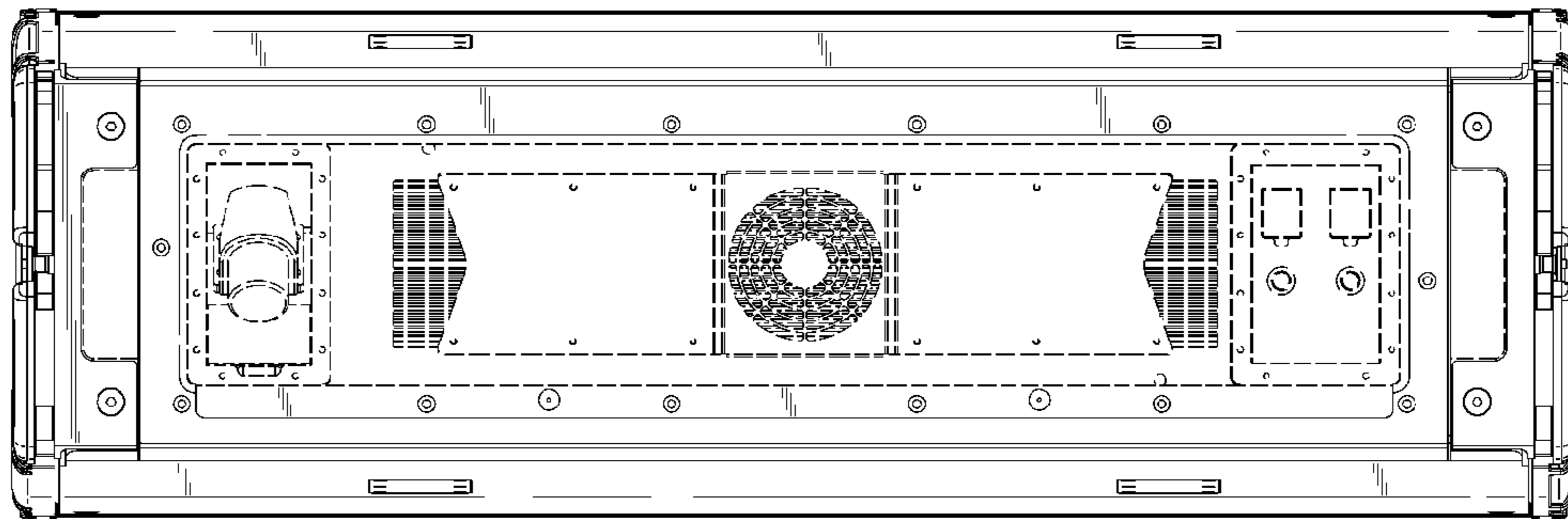

Fig.3.

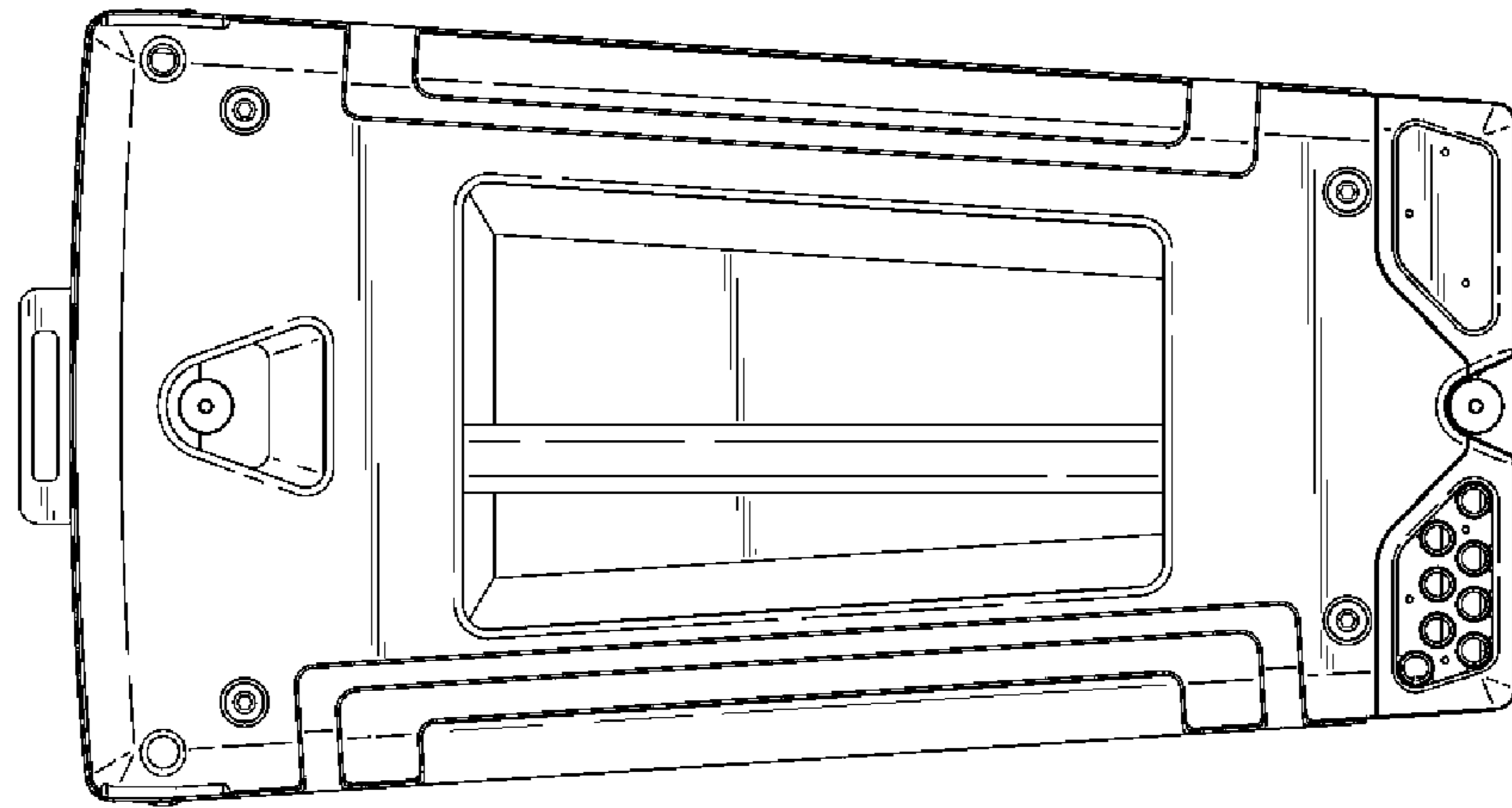

Fig.4.

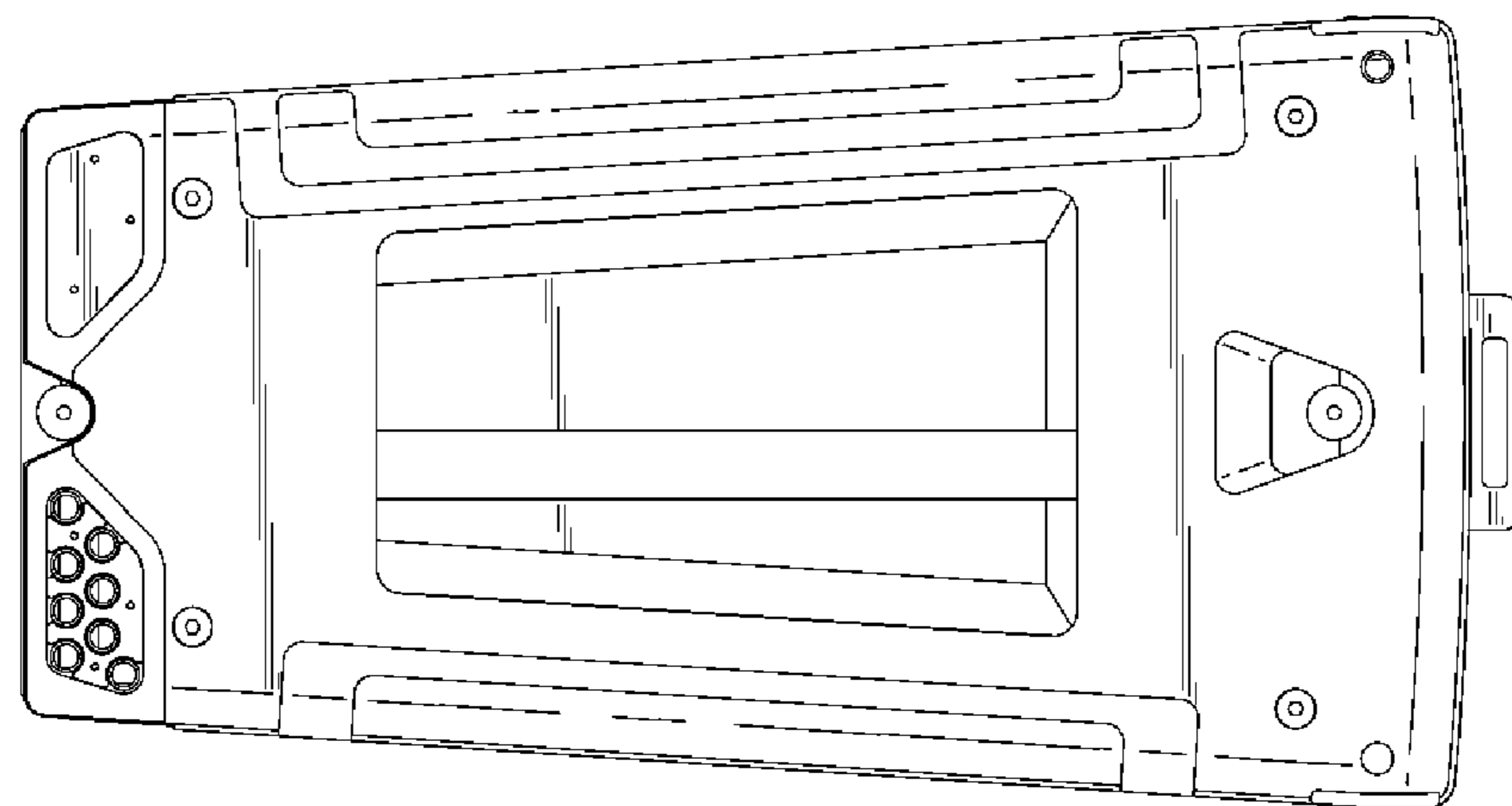

Fig.5.

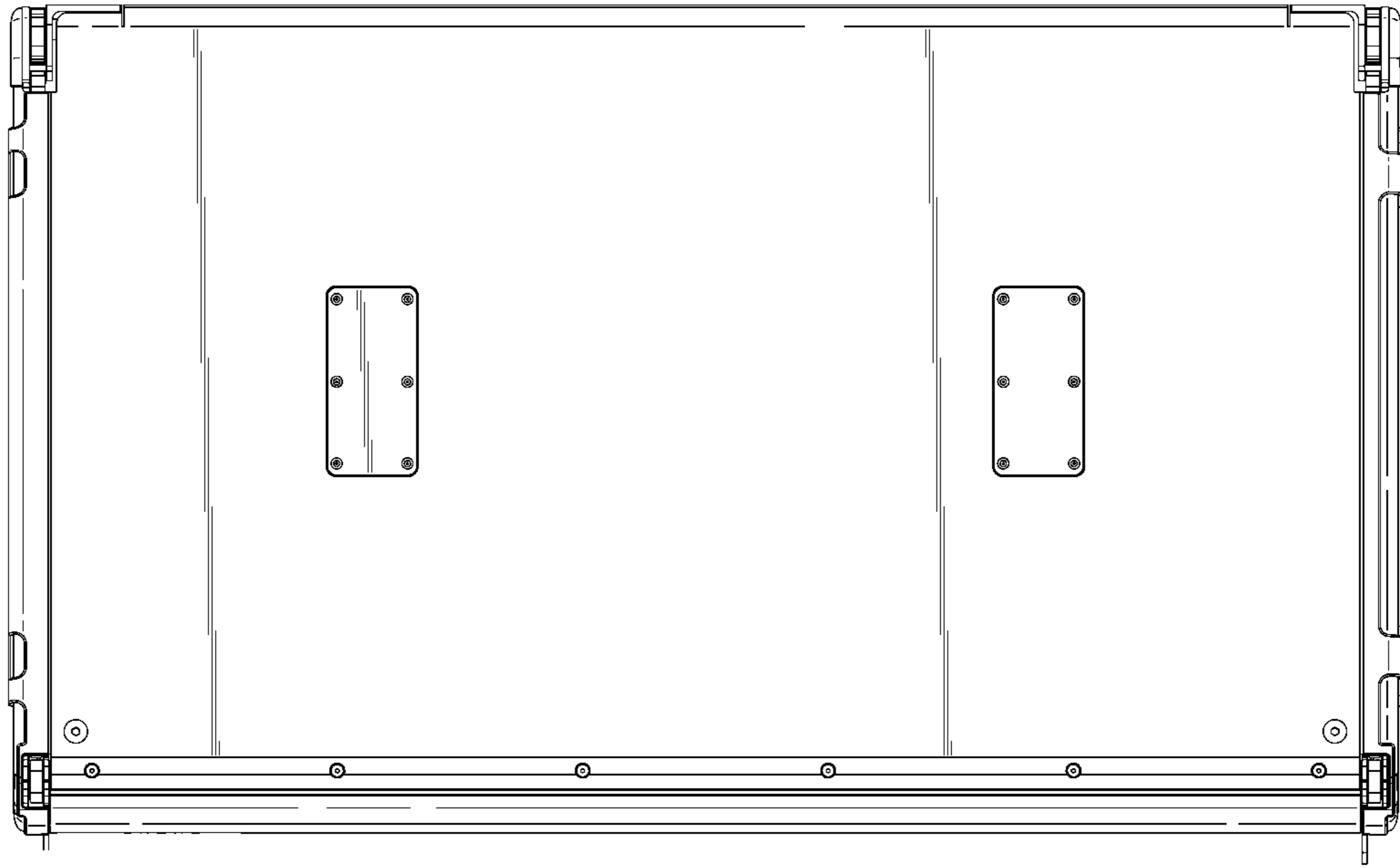

Fig.6.

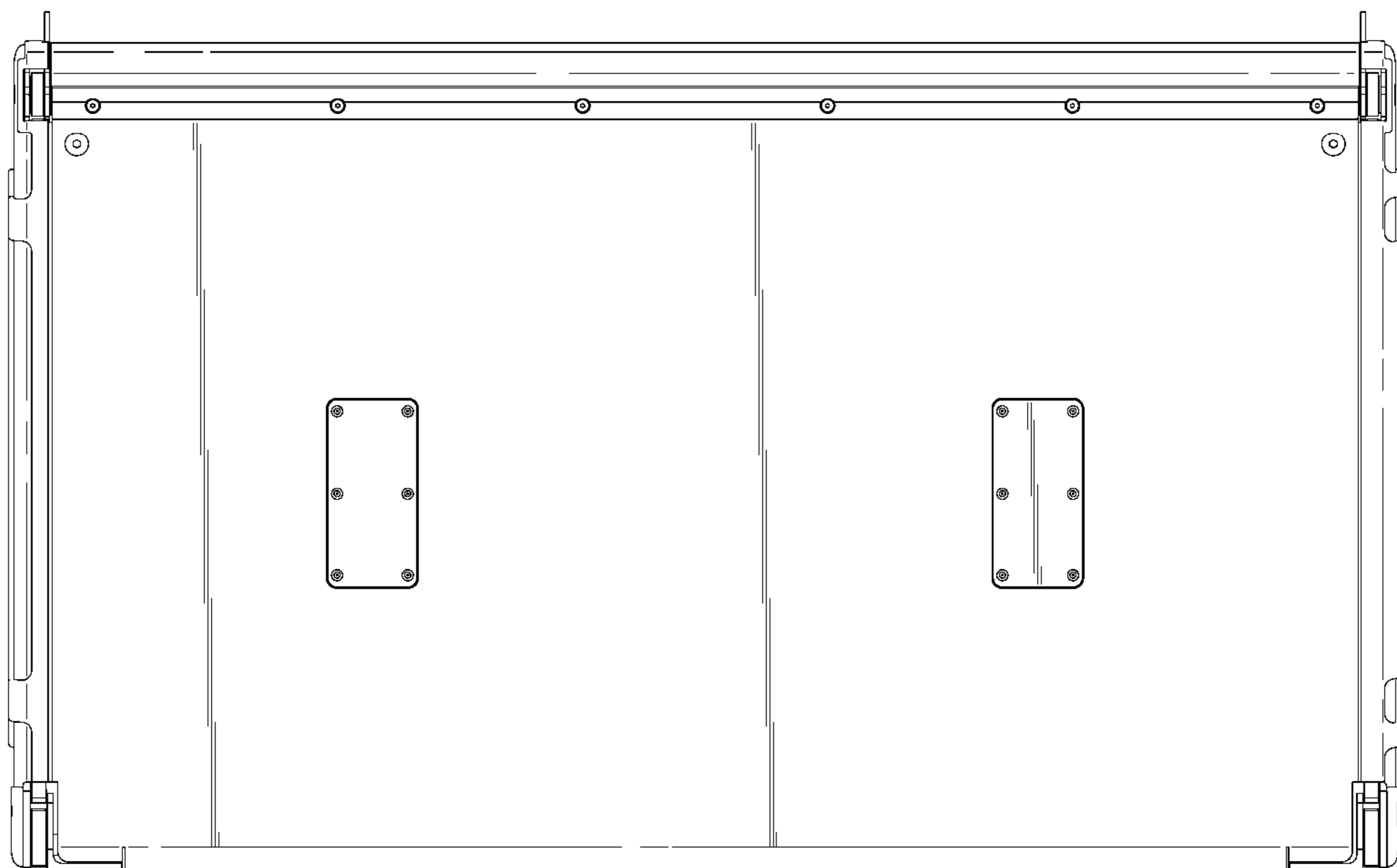

Fig.7.

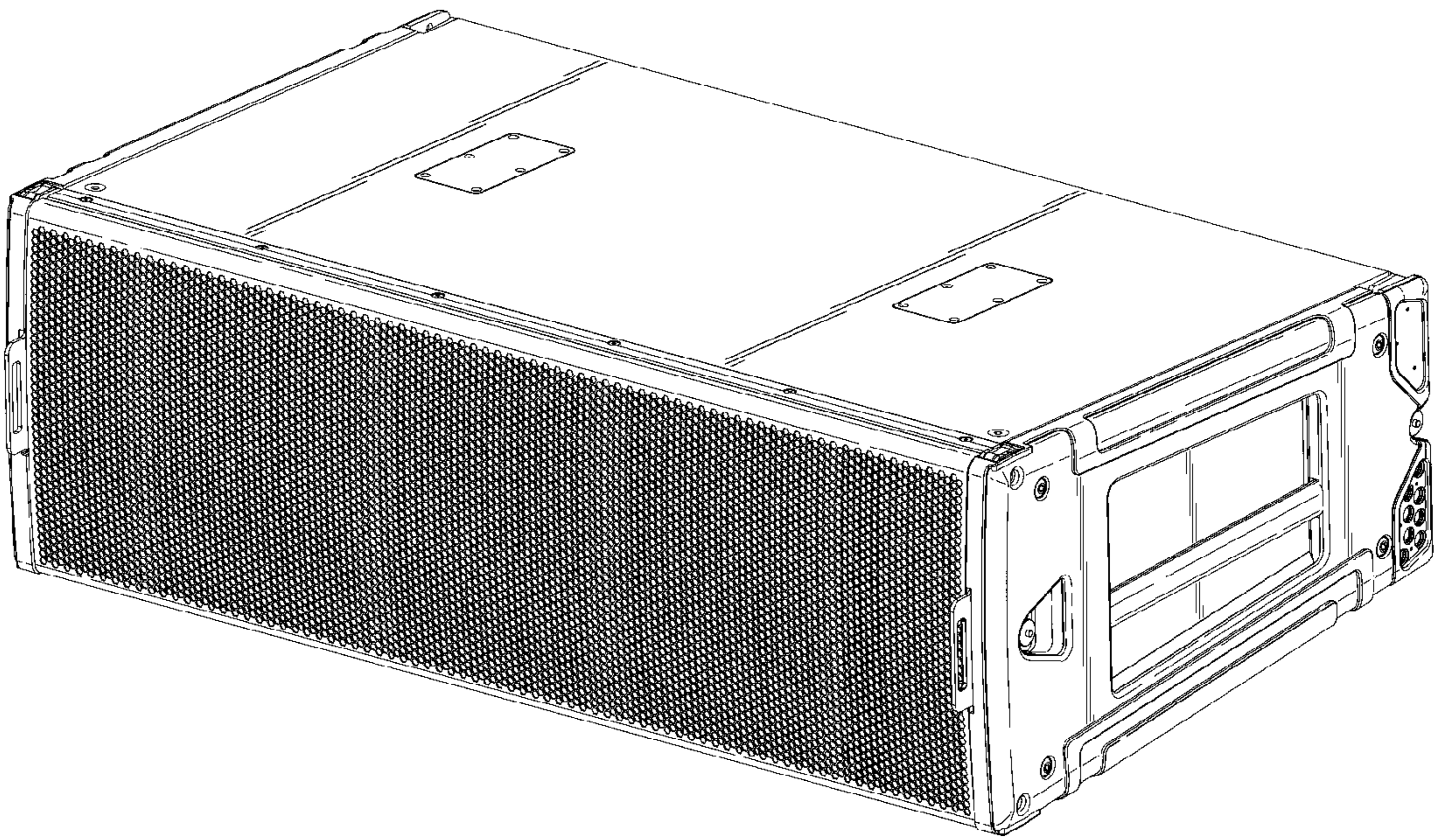

Fig.8.

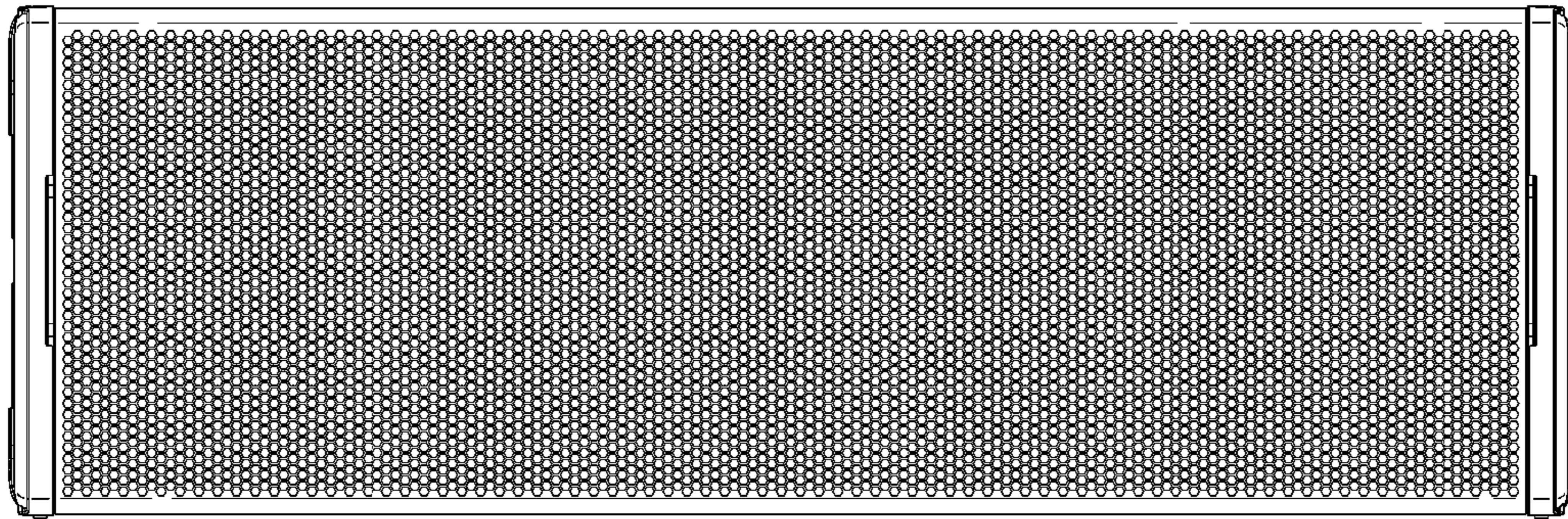

Fig.9.

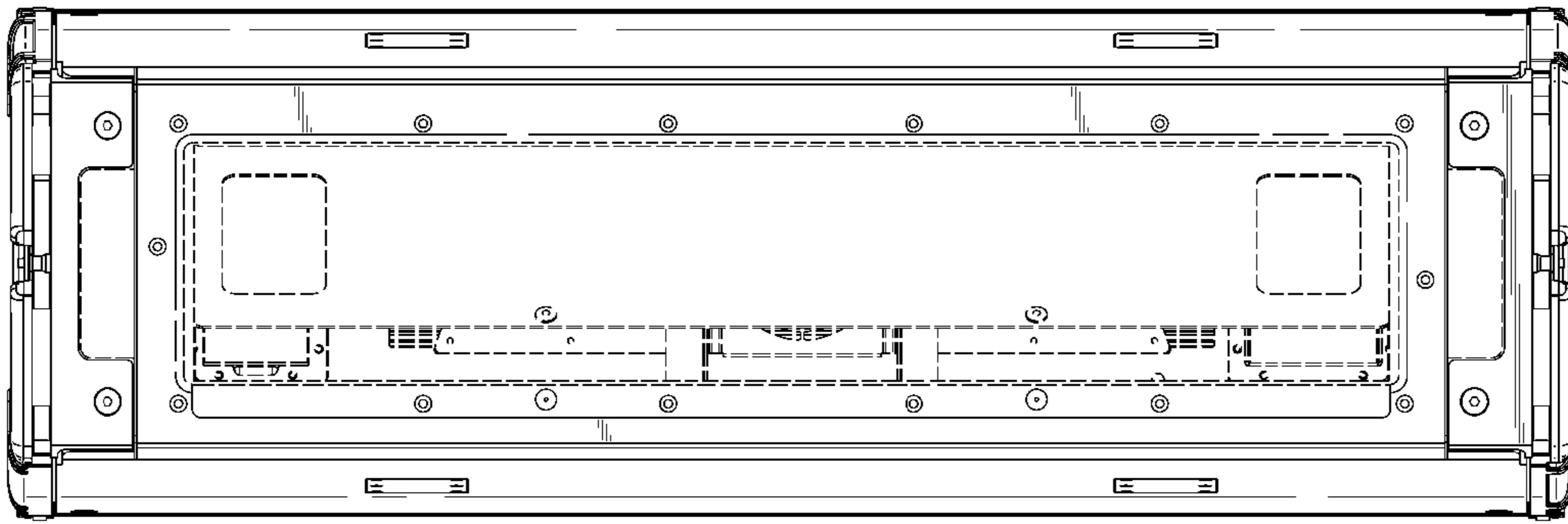

Fig.10.

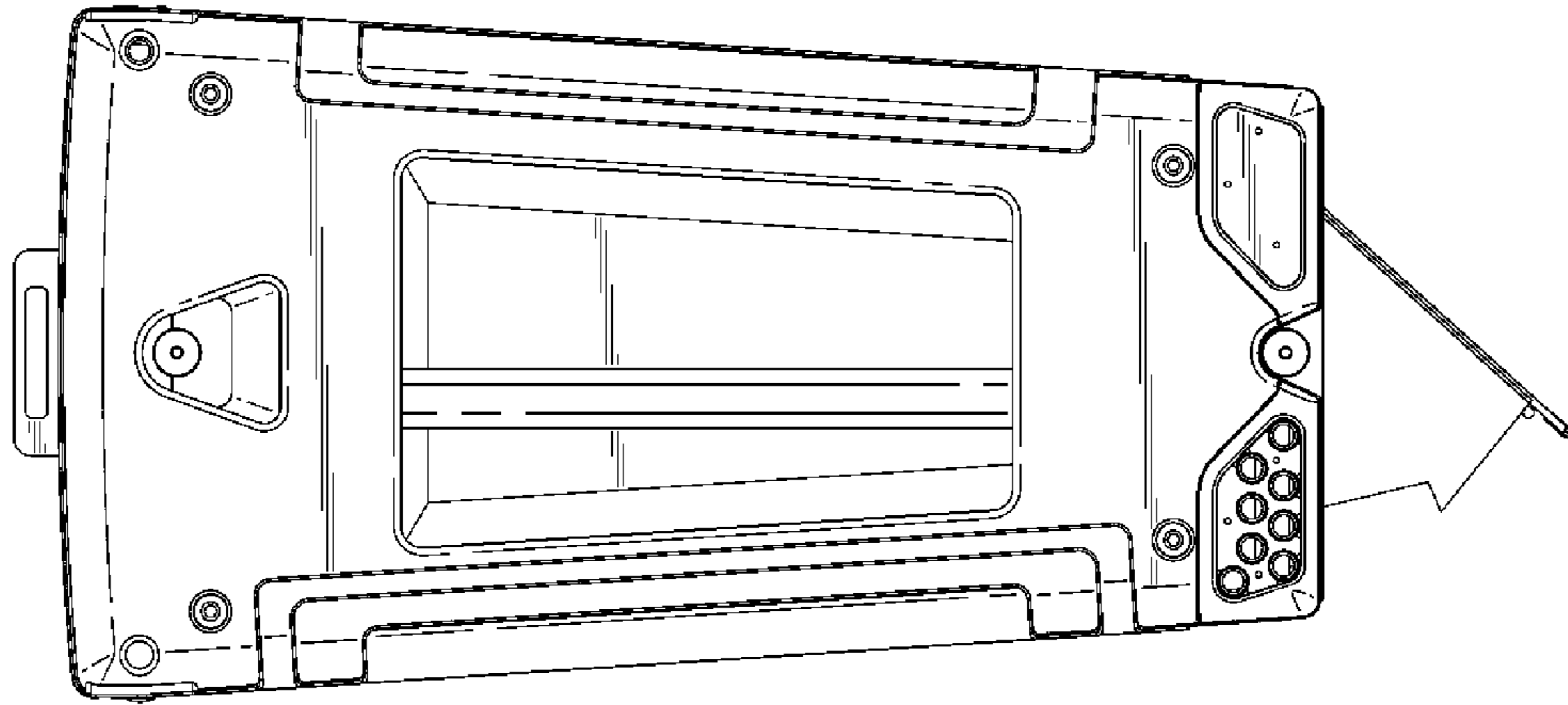

Fig. 11.

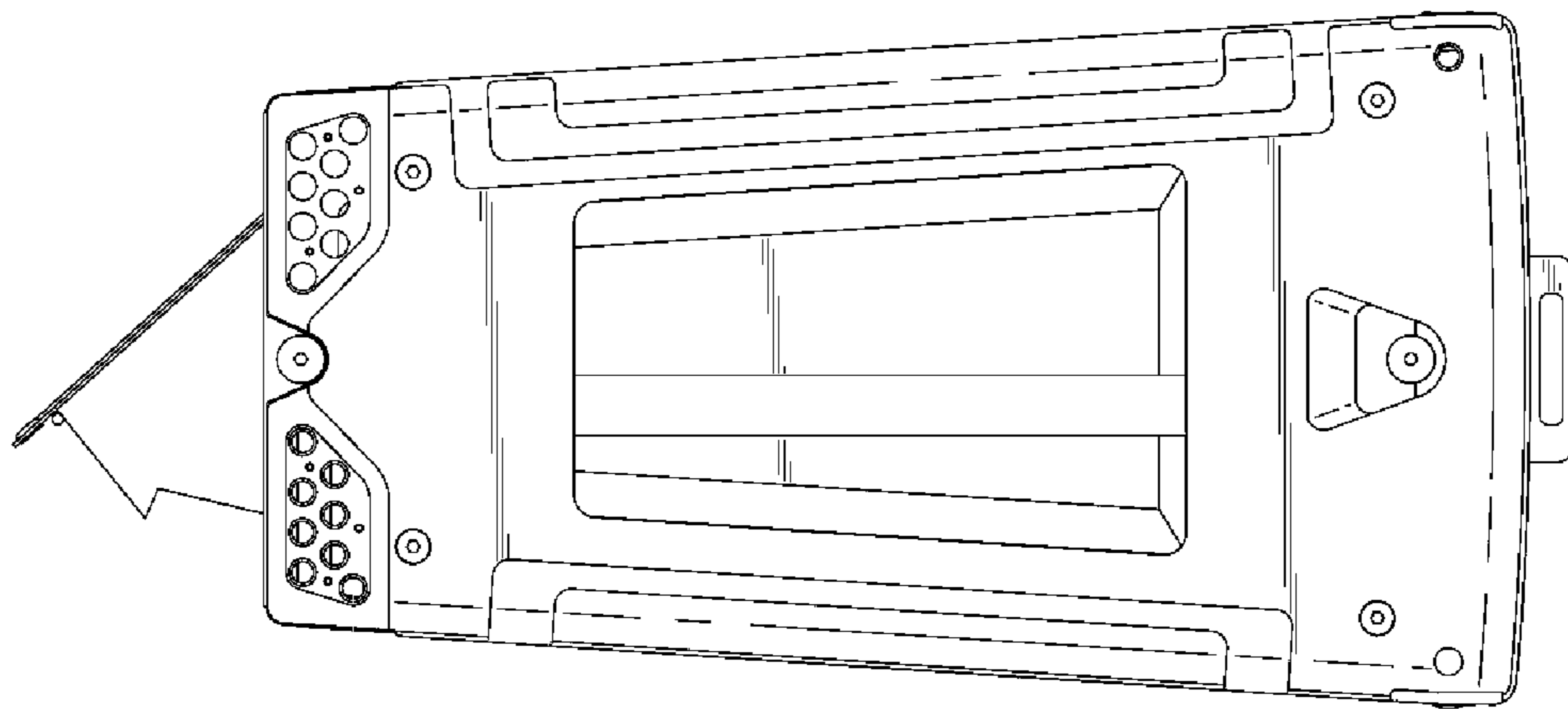

Fig. 12.

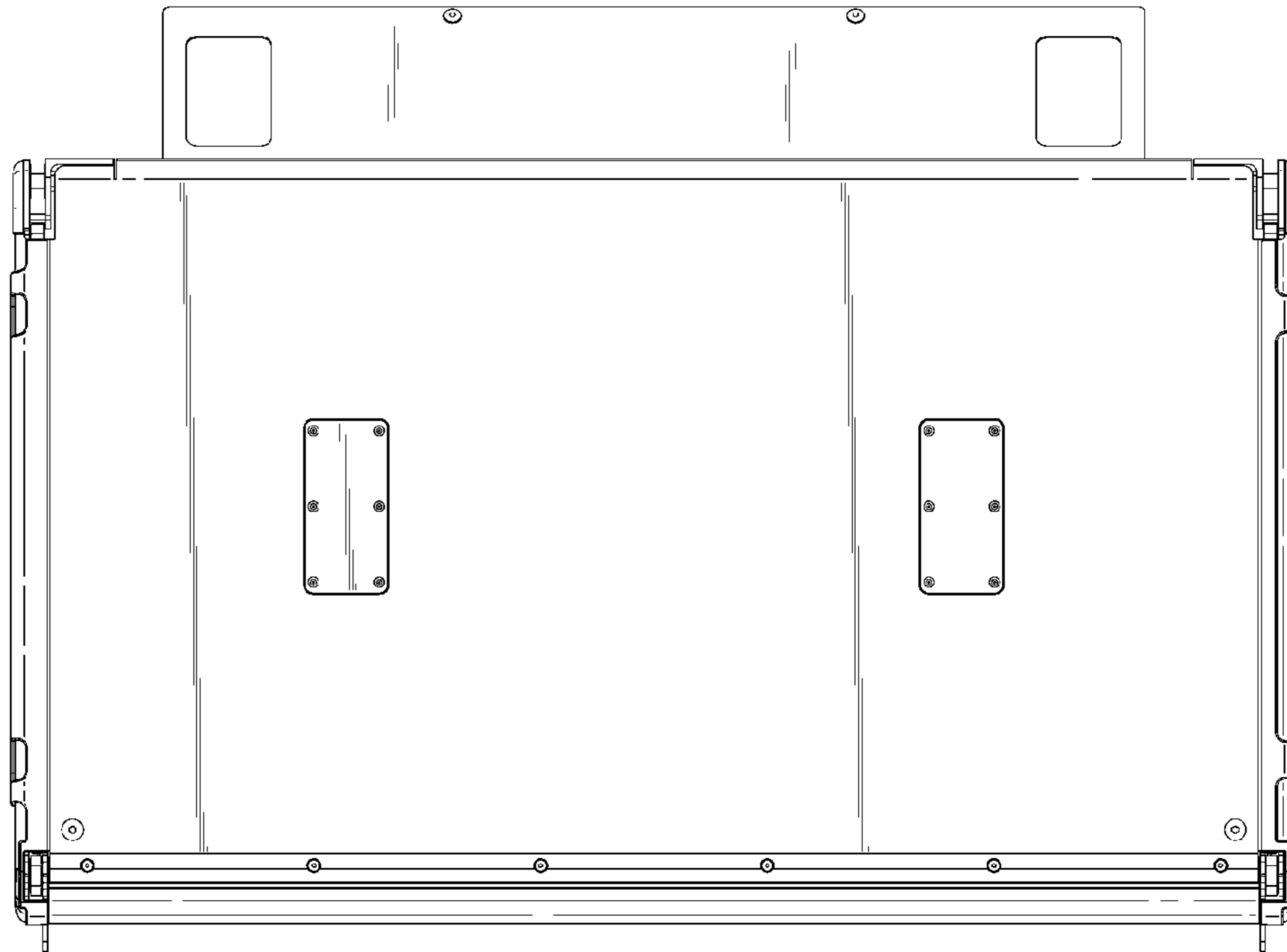

Fig.13.

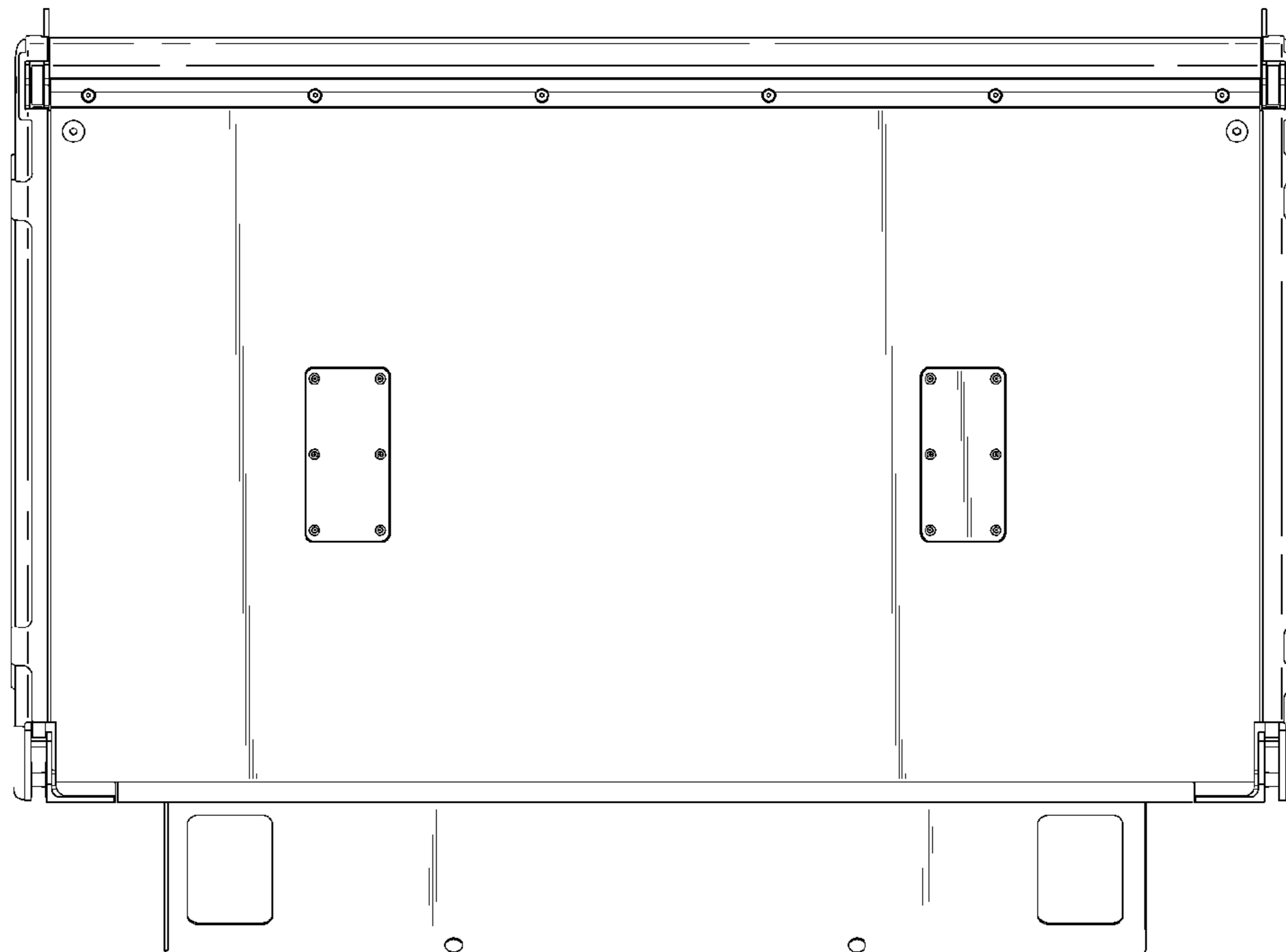

Fig.14.