



US00D640956S

(12) **United States Design Patent**  
**Leahy et al.**

(10) **Patent No.:** **US D640,956 S**  
(45) **Date of Patent:** **\*\* Jul. 5, 2011**

(54) **AUTOMOTIVE GRILLE**

(56) **References Cited**

(75) Inventors: **Andrew Leahy**, Laguna Niguel, CA (US);  
**Nikola Stefanov**, San Clemente, CA  
(US); **Henrik Fisker**, Newport Beach,  
CA (US)

U.S. PATENT DOCUMENTS

D389,438 S	1/1998	Guichard	
D523,778 S	6/2006	Saridakis	
D539,703 S	4/2007	Woodhouse	
D553,053 S	10/2007	McChesney	
D555,042 S	11/2007	Davidson	
D563,277 S	3/2008	Thomas	
D596,089 S *	7/2009	Platto et al.	D12/163
D596,998 S *	7/2009	Hasui	D12/163
D627,272 S *	11/2010	Fisker et al.	D12/163
D631,795 S *	2/2011	Fisker et al.	D12/92

(73) Assignee: **Fisker Automotive, Inc.**, Irvine, CA  
(US)

\* cited by examiner

(\*\*) Term: **14 Years**

*Primary Examiner* — Melody N Brown

(21) Appl. No.: **29/383,987**

(74) *Attorney, Agent, or Firm* — Foley & Lardner LLP

(22) Filed: **Jan. 25, 2011**

(57) **CLAIM**

The ornamental design for an automotive grille, as shown and described.

**Related U.S. Application Data**

**DESCRIPTION**

(62) Division of application No. 29/330,613, filed on Jan. 9, 2009, now Pat. No. Des. 631,795.

(51) **LOC (9) Cl.** ..... **12-16**

(52) **U.S. Cl.** ..... **D12/163**

(58) **Field of Classification Search** ..... D12/163,  
D12/196, 171, 169, 216, 90-92, 86; 180/68.1,  
180/68.6; 296/193.11

FIG. 1 is a front perspective view of an automotive grille shown on the left side of a vehicle in broken lines, the right side is a mirror image of that shown; FIG. 2 is an enlarged front perspective view of the grille; FIG. 3 is a front elevational view of the grille; and, FIG. 4 is another front perspective view thereof. The vehicle shown in broken lines is for illustrative purposes only and forms no part of the claimed design.

See application file for complete search history.

**1 Claim, 4 Drawing Sheets**

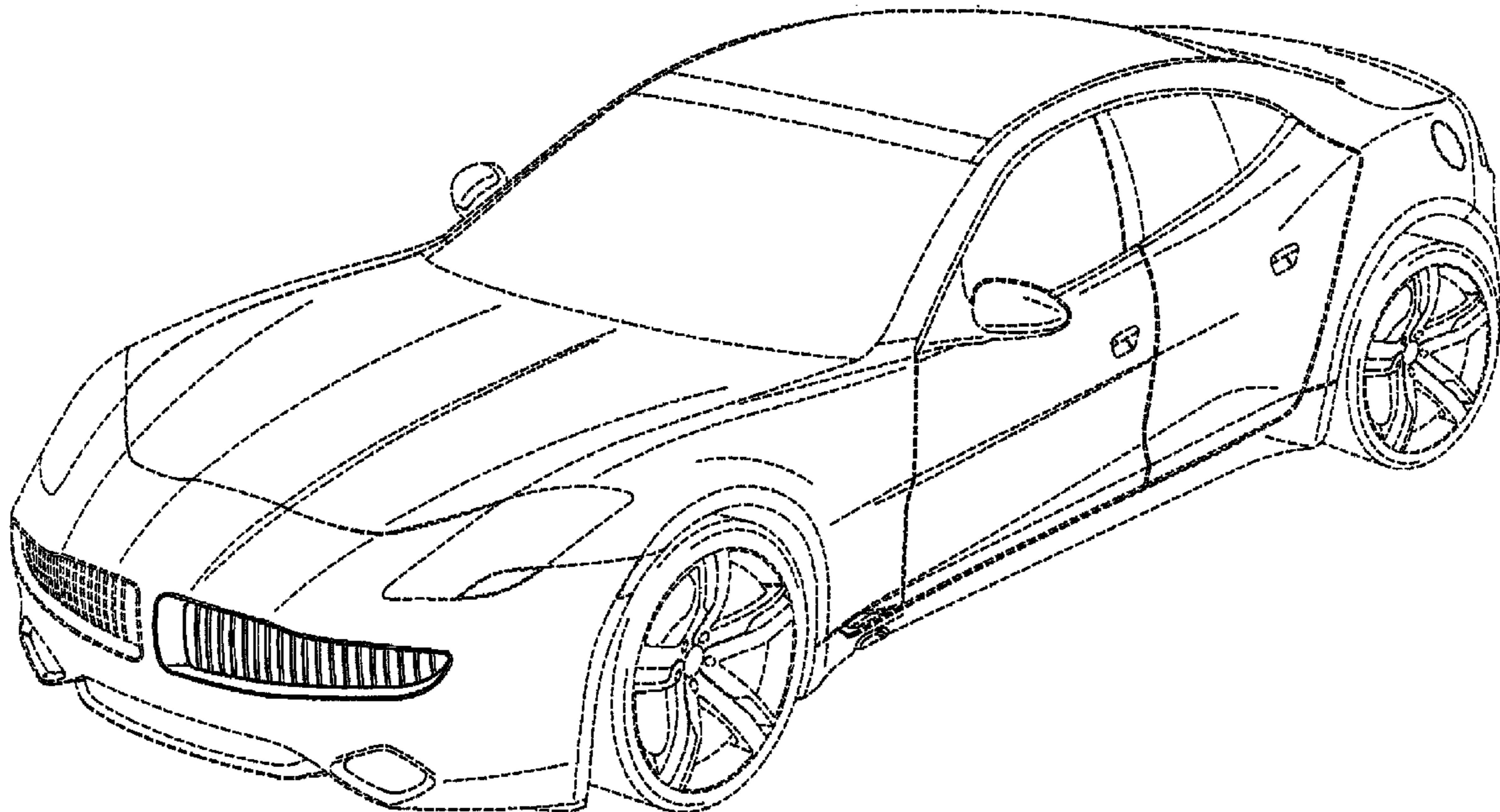

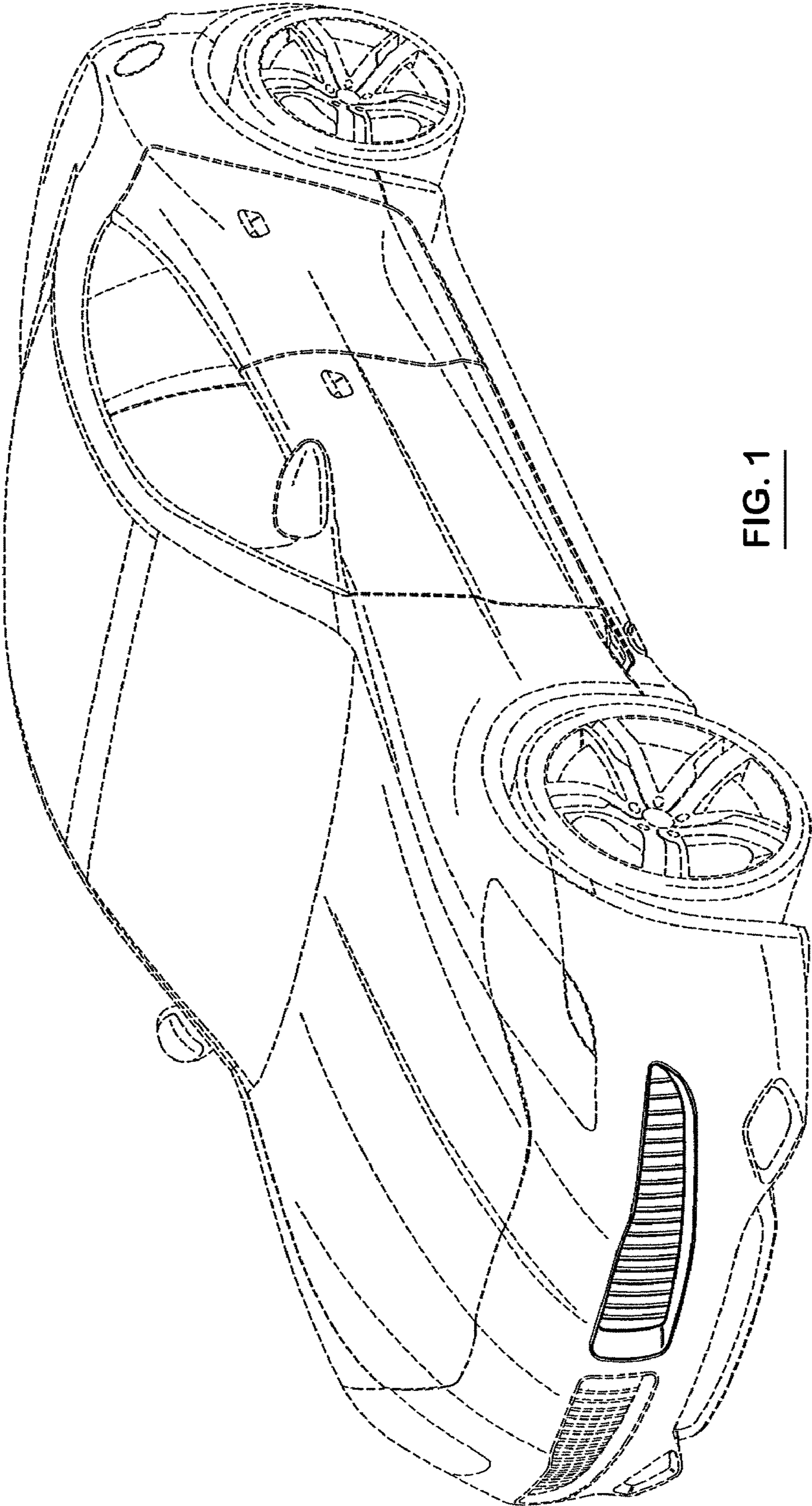

FIG. 1

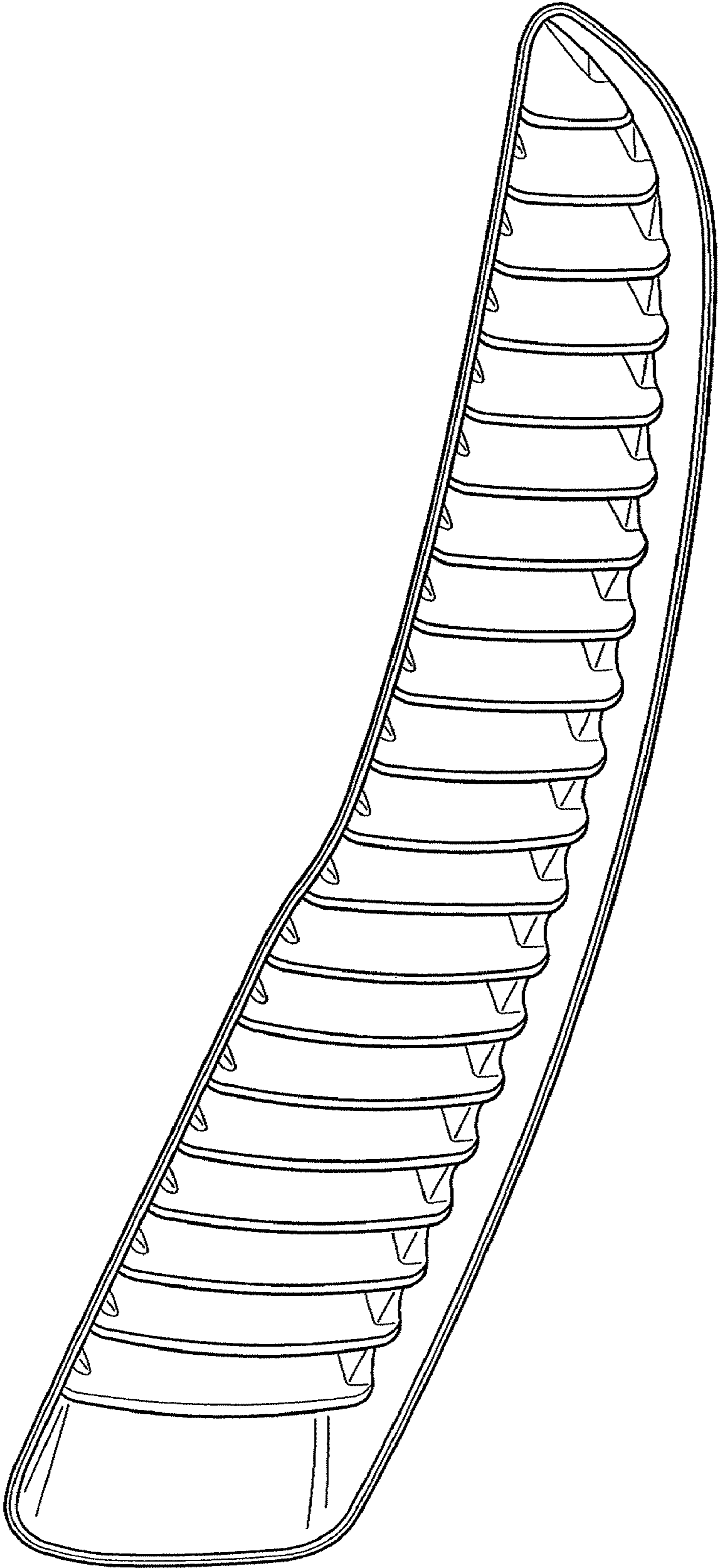

FIG. 2



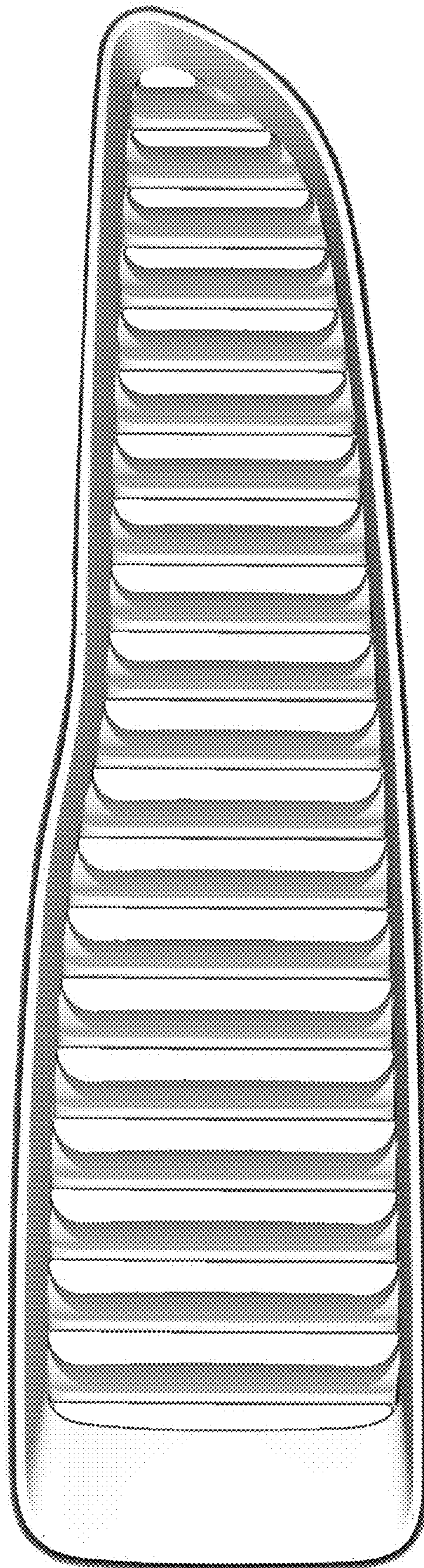

FIG. 3



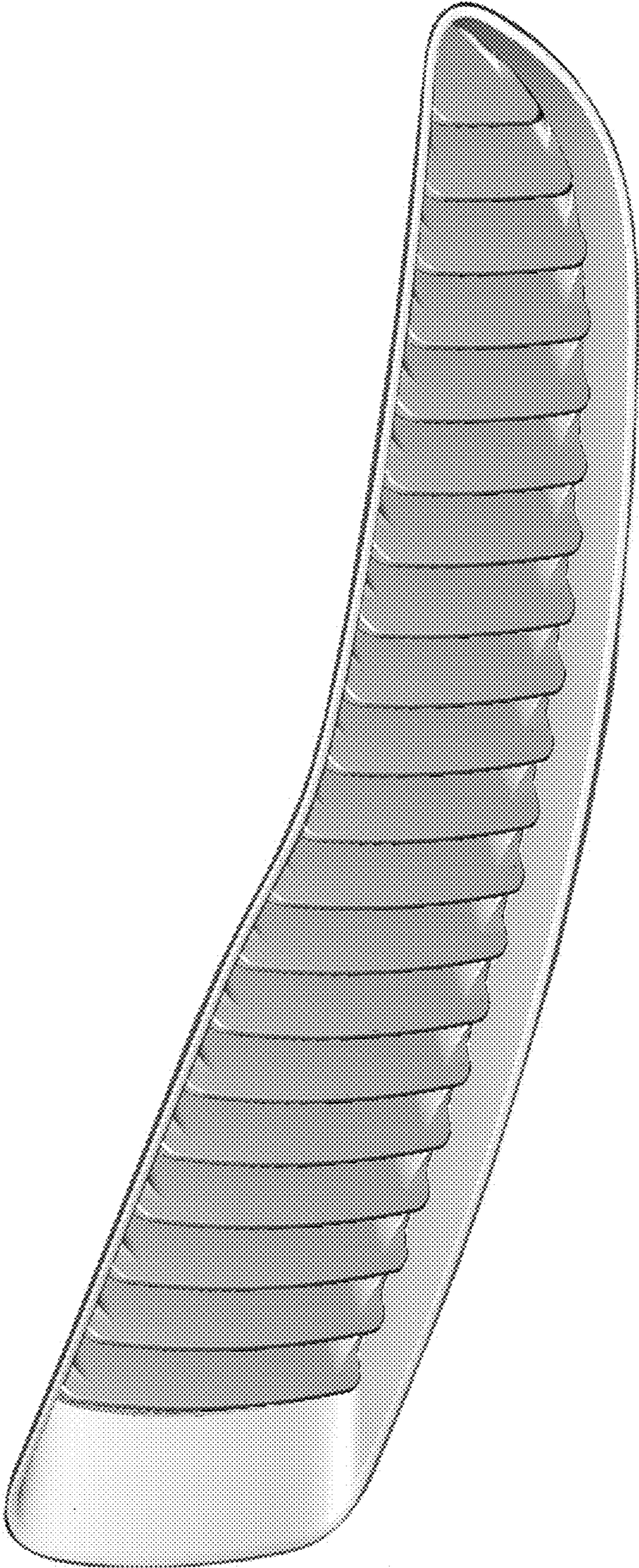

FIG. 4