



US00D640736S

(12) **United States Design Patent**  
**Kimura et al.**

(10) **Patent No.:** **US D640,736 S**  
(45) **Date of Patent:** **\*\* Jun. 28, 2011**

(54) **PRINTER**

(75) Inventors: **Seiji Kimura**, Shiojiri (JP); **Kanako Nakatani**, Matsumoto (JP); **Yoshiki Kinoshita**, Suwa (JP); **Masaaki Nakamura**, Shiojiri (JP); **Tomohisa Kano**, Shiojiri (JP)

(73) Assignee: **Seiko Epson Corporation** (JP)

(\*\*) Term: **14 Years**

(21) Appl. No.: **29/368,895**

(22) Filed: **Aug. 31, 2010**

(30) **Foreign Application Priority Data**

Mar. 12, 2010 (JP) ..... 2010-006047

(51) **LOC (9) Cl.** ..... **14-02**

(52) **U.S. Cl.** ..... **D18/50**

(58) **Field of Classification Search** ..... D18/19,  
D18/34.1, 36-37, 50, 54, 54.1, 55; D14/420-425,  
D14/434, 463-470; 400/613, 613.1-613.4,  
400/690, 690.1-690.4, 691-694  
See application file for complete search history.

(56) **References Cited**

**U.S. PATENT DOCUMENTS**

D210,752 S \* 4/1968 Austin ..... D18/36

D263,142 S \* 2/1982 Nishi et al. .... D18/54  
D288,568 S \* 3/1987 Hara et al. .... D18/54  
D308,072 S \* 5/1990 Salmonson ..... D18/54  
D418,157 S \* 12/1999 Han ..... D18/50  
D465,236 S \* 11/2002 Fukasawa et al. .... D18/50  
D523,072 S \* 6/2006 Lee et al. .... D18/50

\* cited by examiner

*Primary Examiner* — Cathy A MacCormac

(74) *Attorney, Agent, or Firm* — Harness, Dickey & Pierce, P.L.C.

(57) **CLAIM**

The ornamental design for a printer, as shown and described.

**DESCRIPTION**

FIG. 1 is a perspective view of a printer, as viewed from the top, front and right side, embodying our new design;

FIG. 2 is a front view thereof;

FIG. 3 is a rear view thereof;

FIG. 4 is a left side view thereof;

FIG. 5 is a right side view thereof;

FIG. 6 is a top view thereof; and,

FIG. 7 is a bottom view thereof.

The broken lines are for illustrative purposes only and form no part of the claimed invention.

**1 Claim, 4 Drawing Sheets**

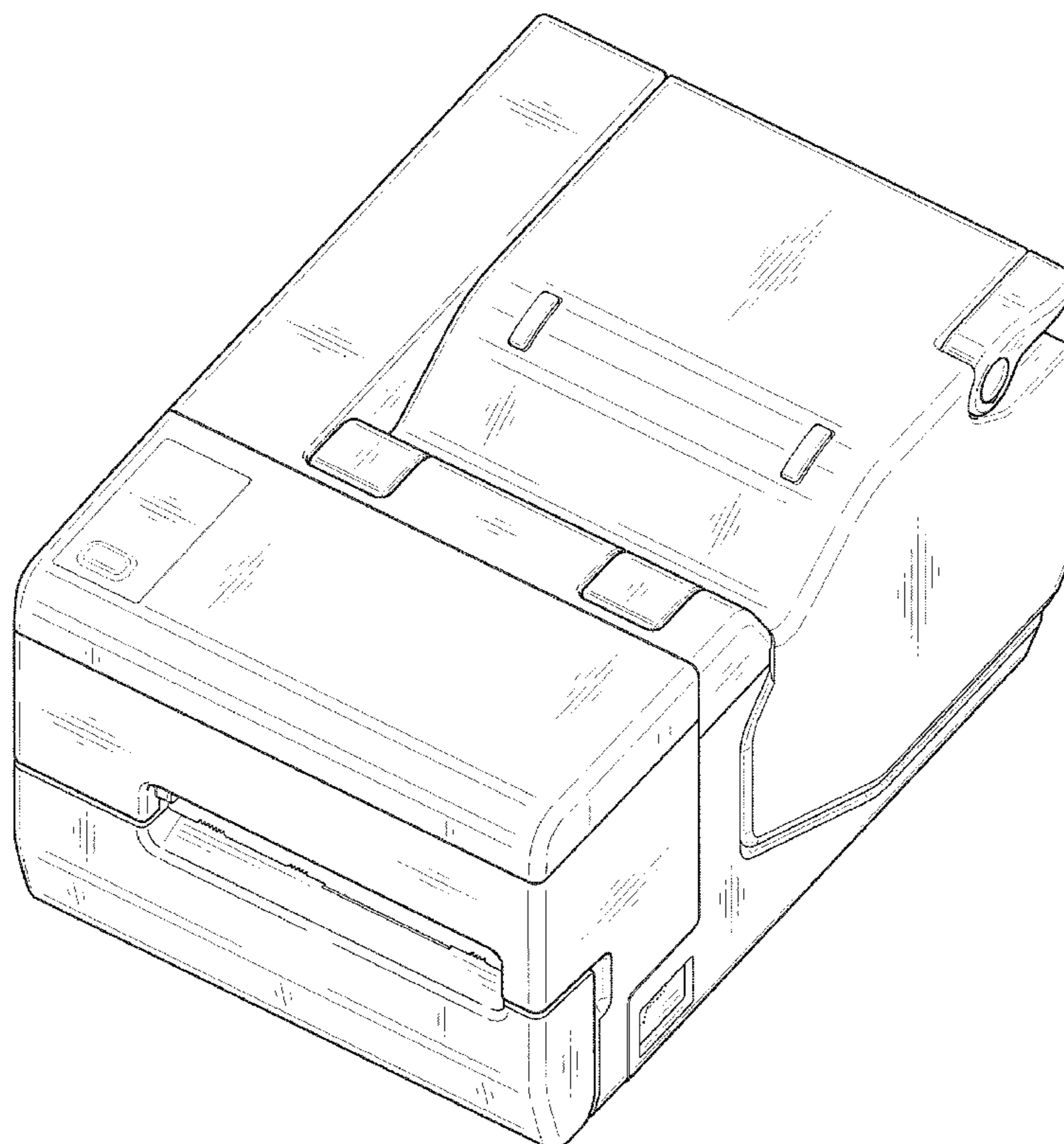

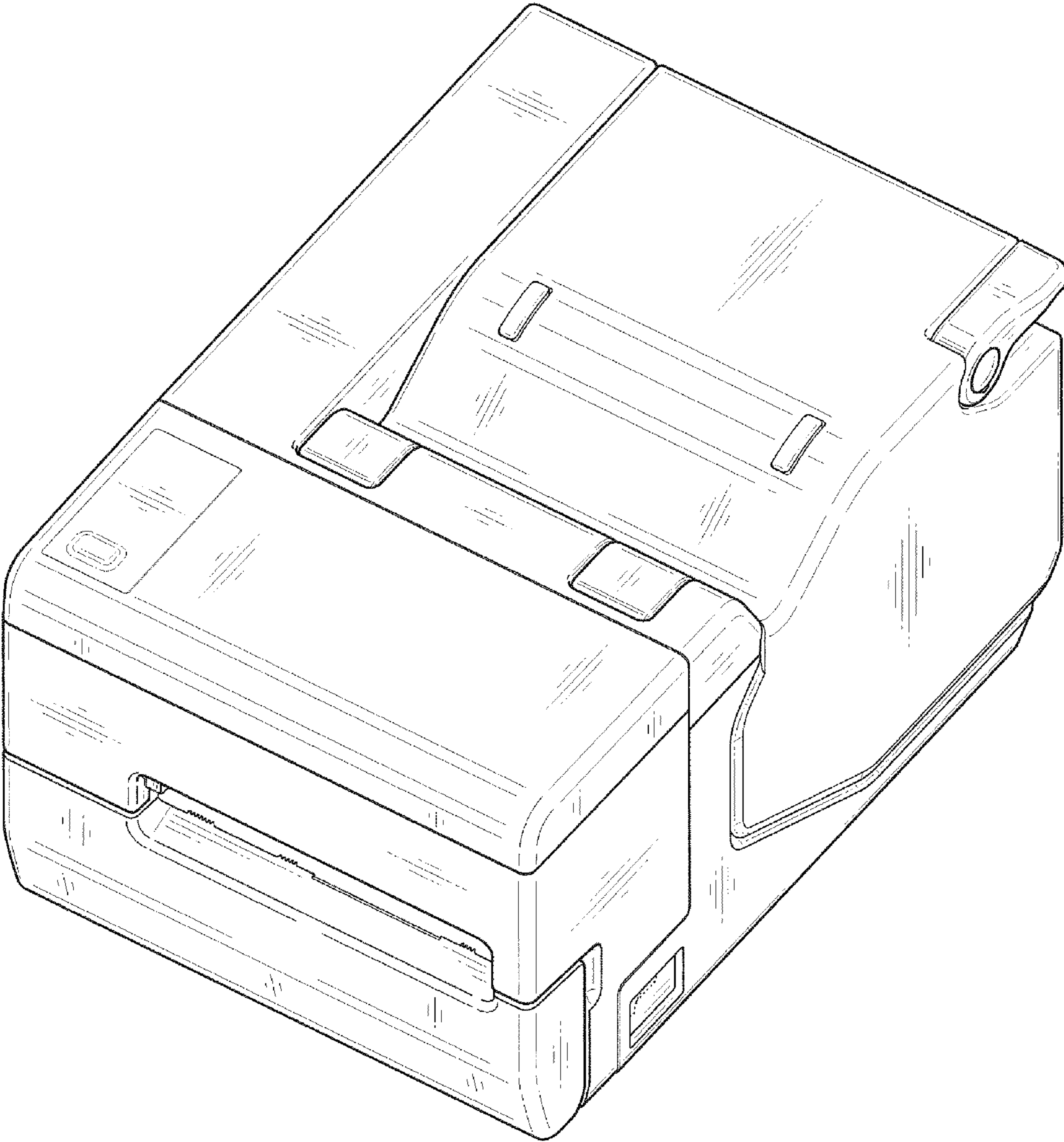

FIG. 1

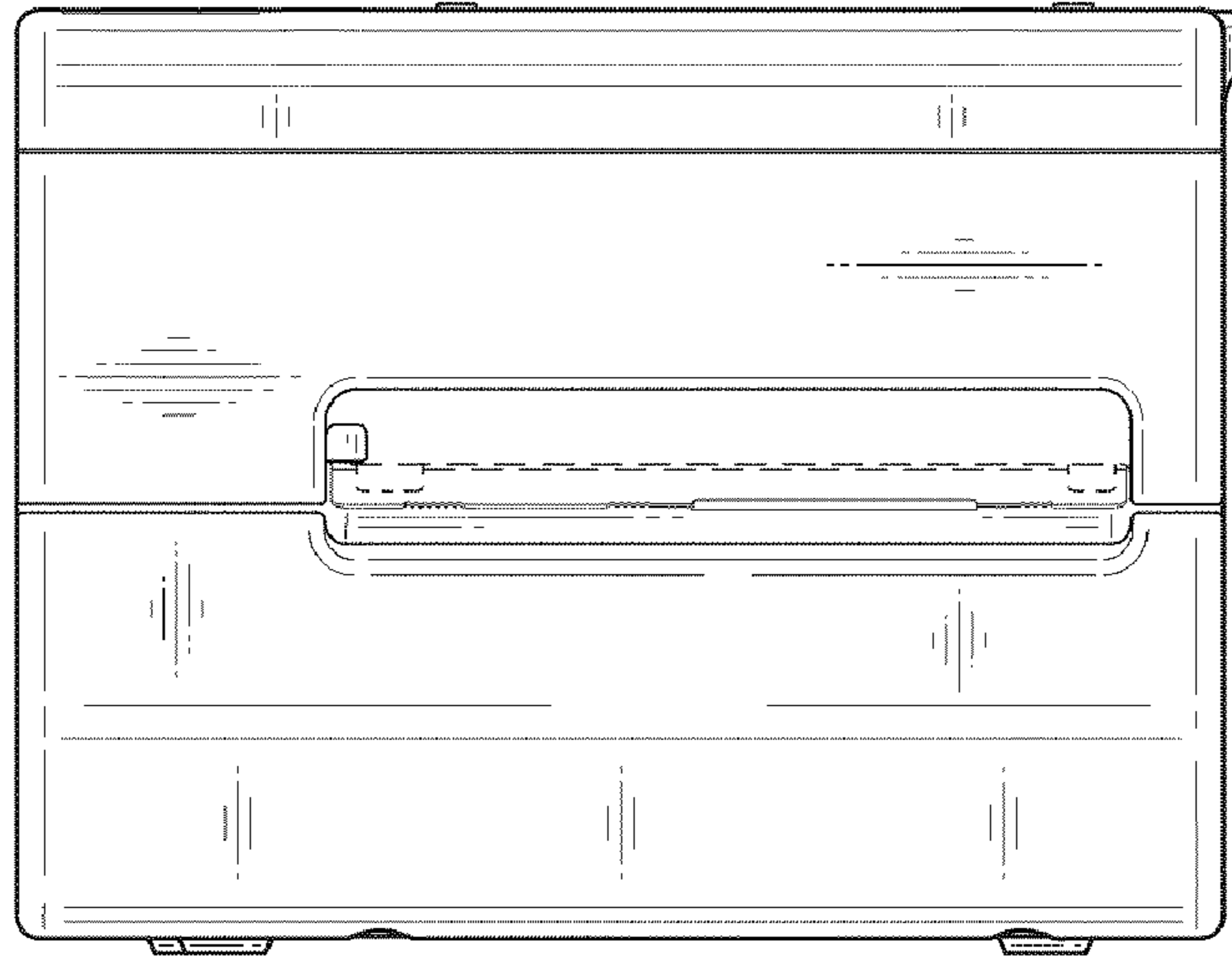

FIG. 2

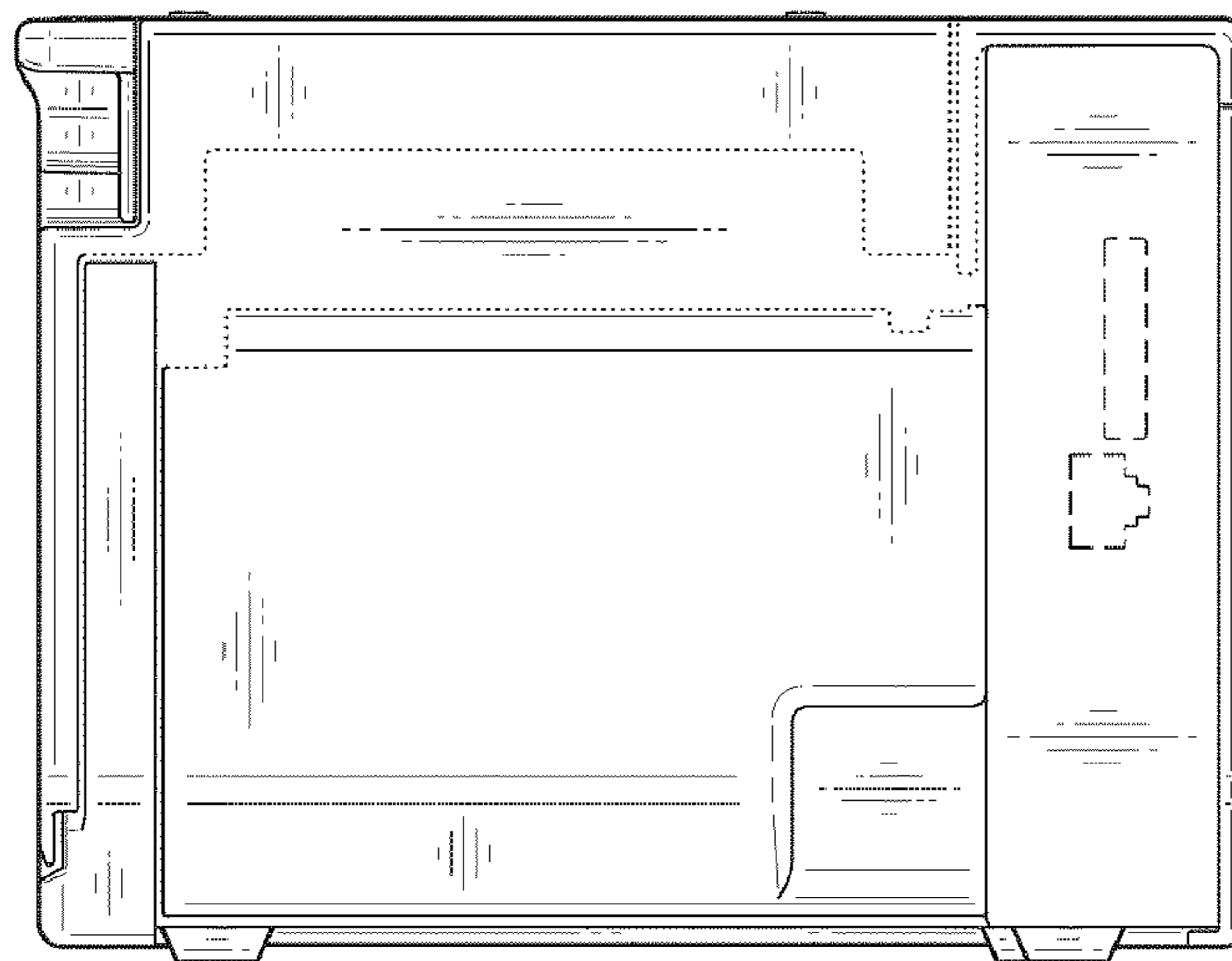

FIG. 3

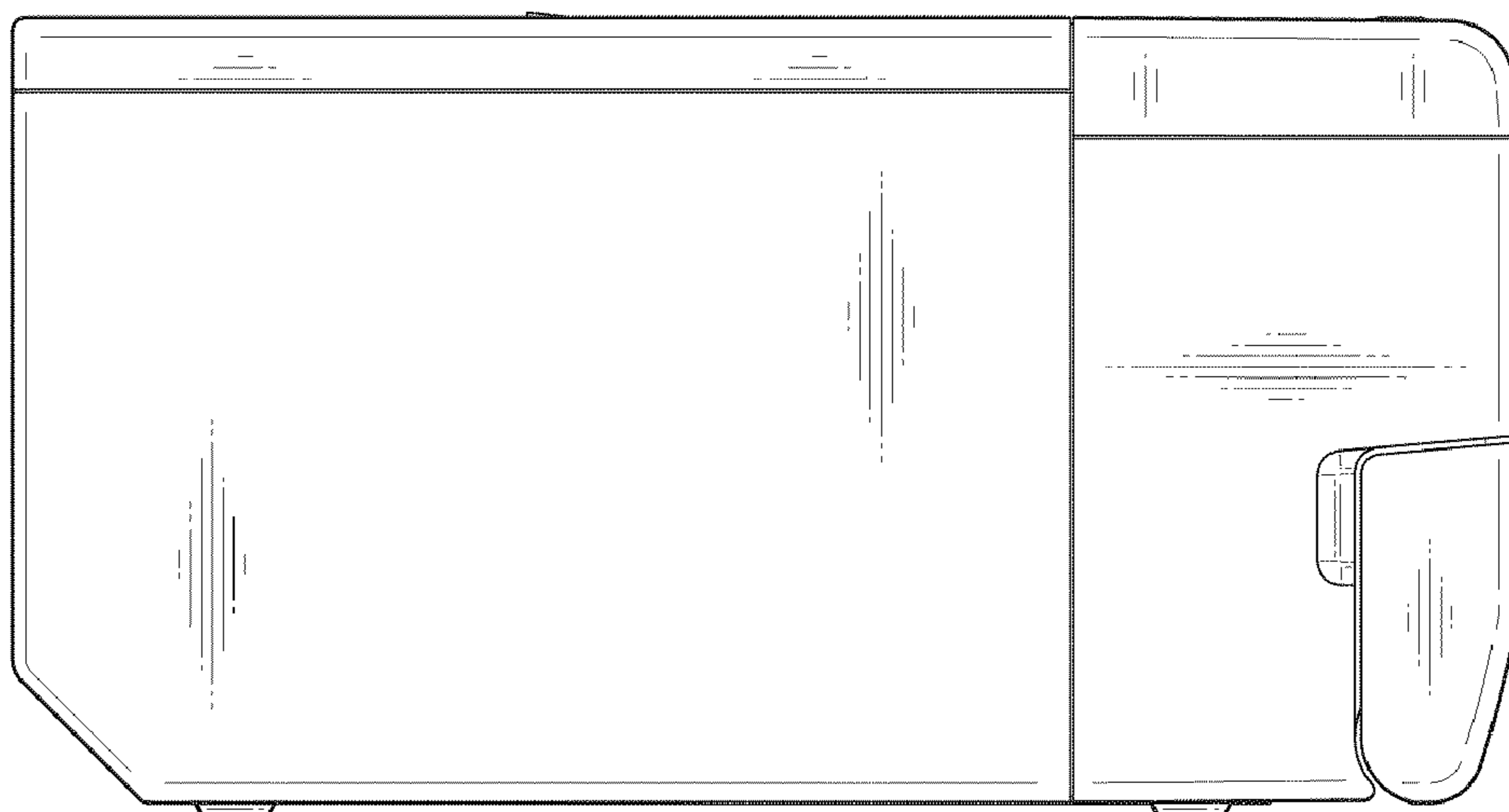

FIG. 4

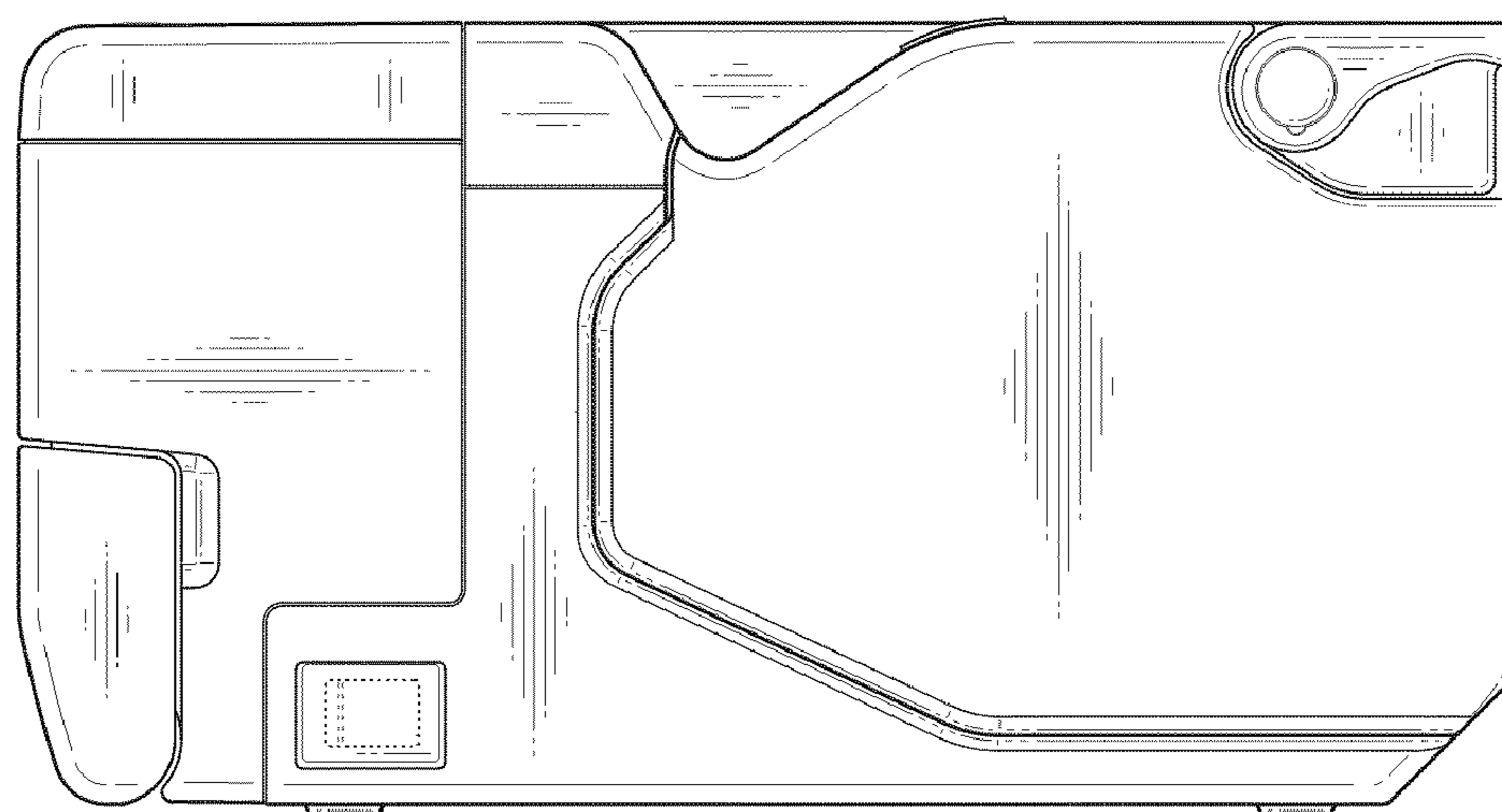

FIG. 5

FIG. 6

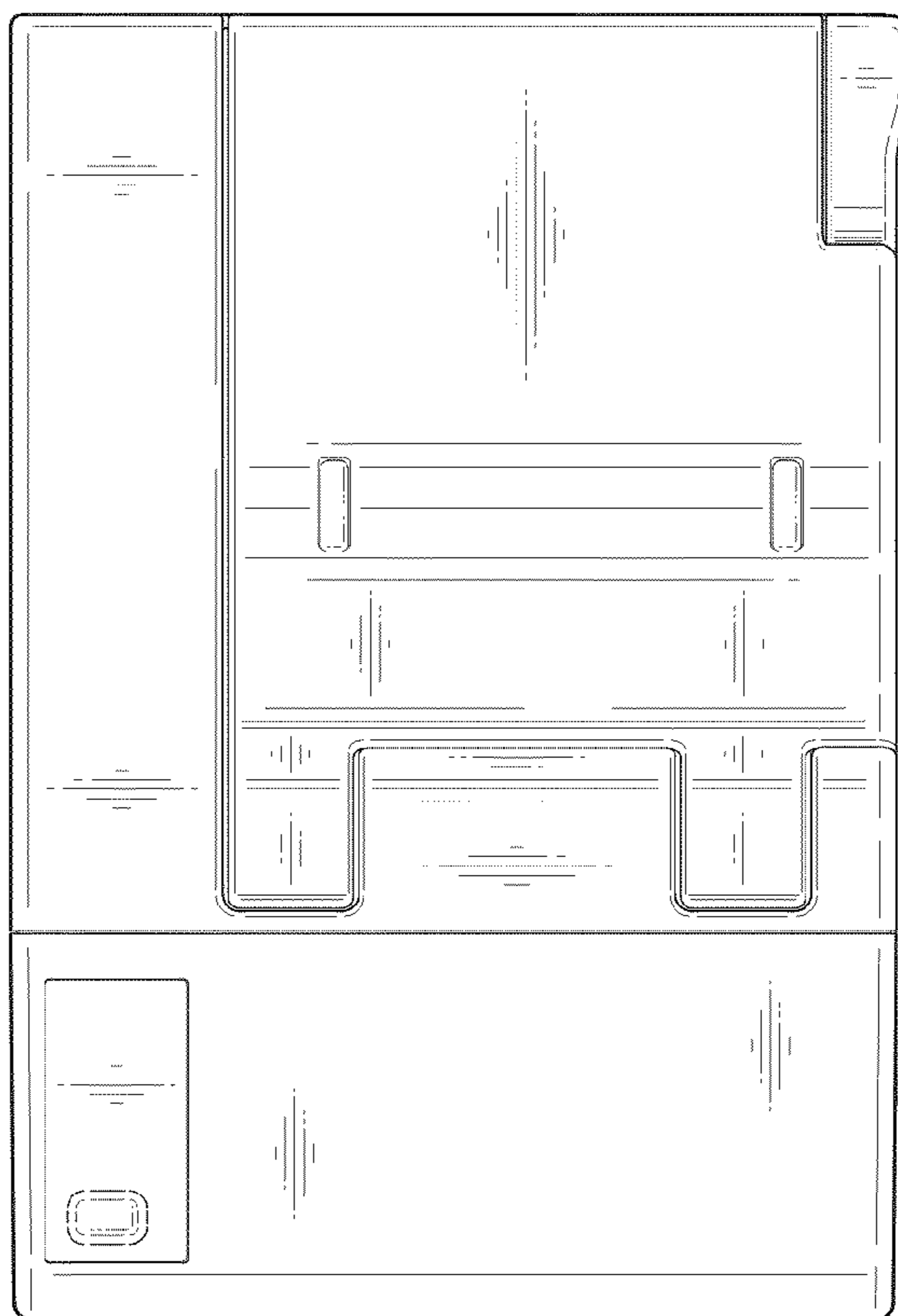

FIG. 7

