

US00D640606S

(12) **United States Design Patent**
Lai et al.

(10) **Patent No.:** **US D640,606 S**
(45) **Date of Patent:** **** Jun. 28, 2011**

(54) **MOTORCYCLE**

(56) **References Cited**

(75) Inventors: **Guogui Lai**, Hangzhou (CN); **Yongzhou Zhao**, Hangzhou (CN); **Zhangping Yuan**, Hangzhou (CN); **Changwei Wang**, Hangzhou (CN); **Danfei Zheng**, Hangzhou (CN); **Hao Jiang**, Hangzhou (CN); **Xiuju Yang**, Hangzhou (CN); **Yueke Song**, Hangzhou (CN)

U.S. PATENT DOCUMENTS

D470,800	S	*	2/2003	Muta et al.	D12/110
D476,271	S	*	6/2003	Abe et al.	D12/110
D519,415	S	*	4/2006	Hohdorf et al.	D12/110
D530,244	S	*	10/2006	Wilm et al.	D12/110
D531,936	S	*	11/2006	Ito et al.	D12/110
D574,299	S	*	8/2008	Kouchi et al.	D12/110
D615,000	S	*	5/2010	Tako et al.	D12/110

* cited by examiner

(73) Assignee: **Zhejiang CFMOTO Power Co., Ltd**, Hangzhou, Zhejiang Province (CN)

Primary Examiner — Susan M Lee

Assistant Examiner — Linda G Brooks

(**) Term: **14 Years**

(74) *Attorney, Agent, or Firm* — Wolf, Greenfield & Sacks, P.C.

(21) Appl. No.: **29/358,697**

(57) **CLAIM**

The ornamental design for a motorcycle, as shown and described.

(22) Filed: **Mar. 31, 2010**

DESCRIPTION

(30) **Foreign Application Priority Data**

Dec. 30, 2009 (CN) 2009 3 0385624

(51) **LOC (9) Cl.** **12-11**

(52) **U.S. Cl.** **D12/110**

(58) **Field of Classification Search** D12/110;
180/219, 220, 225, 229

FIG. 1 is a left side view of the motorcycle;

FIG. 2 is a right side view thereof;

FIG. 3 is a front view thereof;

FIG. 4 is a rear view thereof;

FIG. 5 is a top view thereof; and,

FIG. 6 is a perspective view thereof.

The broken lines illustrate portions of the motorcycle that form no part of the claimed design.

See application file for complete search history.

1 Claim, 6 Drawing Sheets

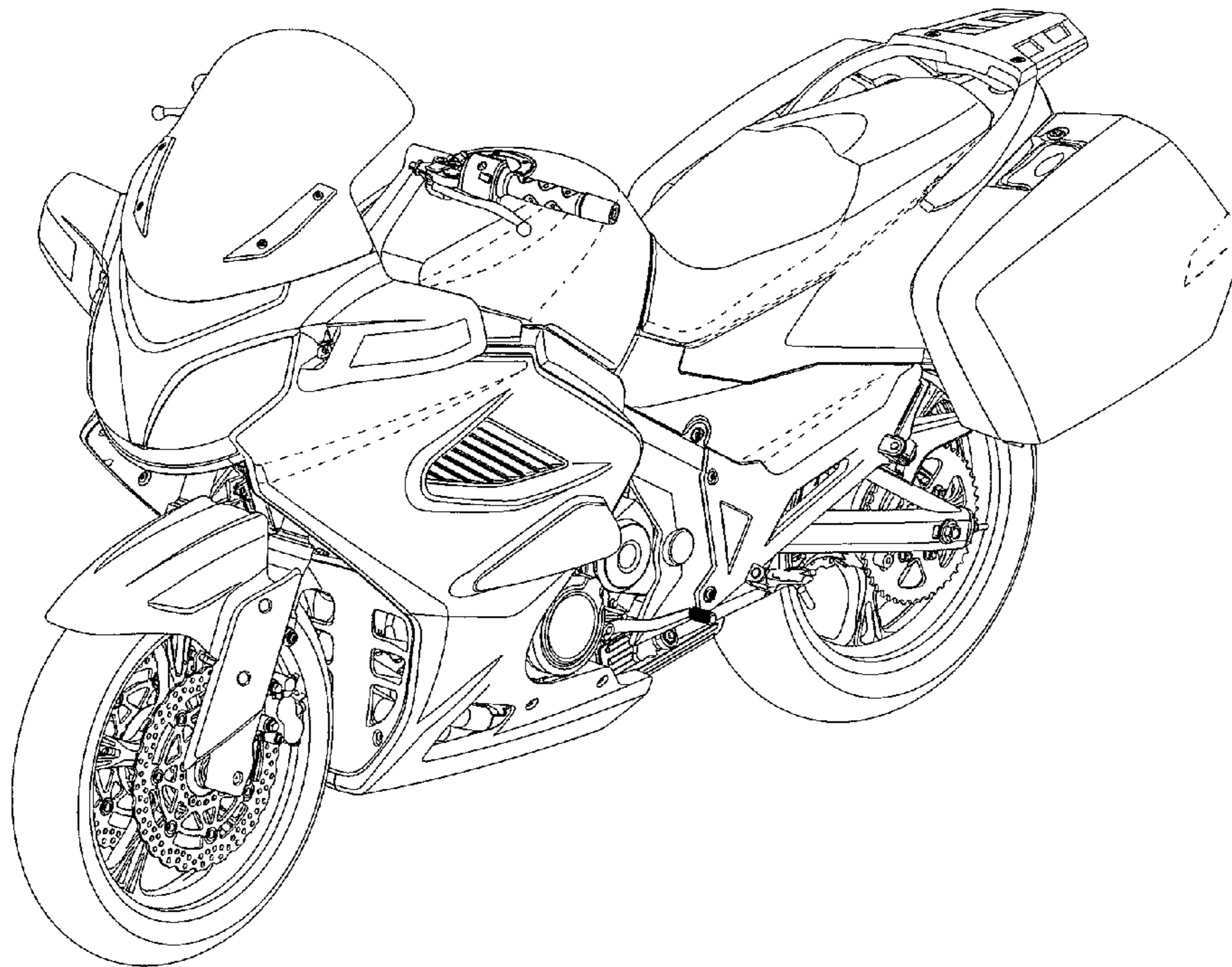

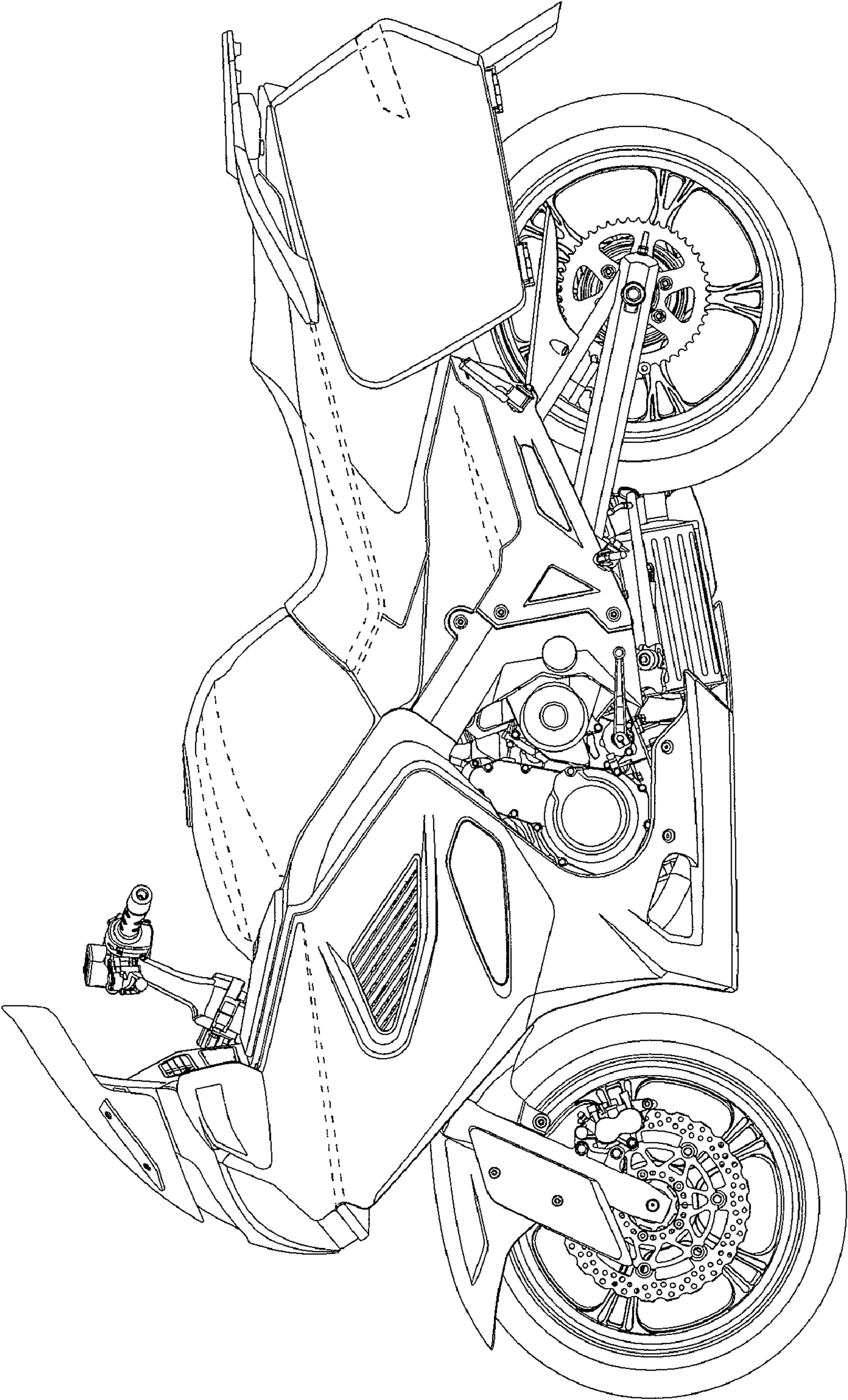

FIG. 1

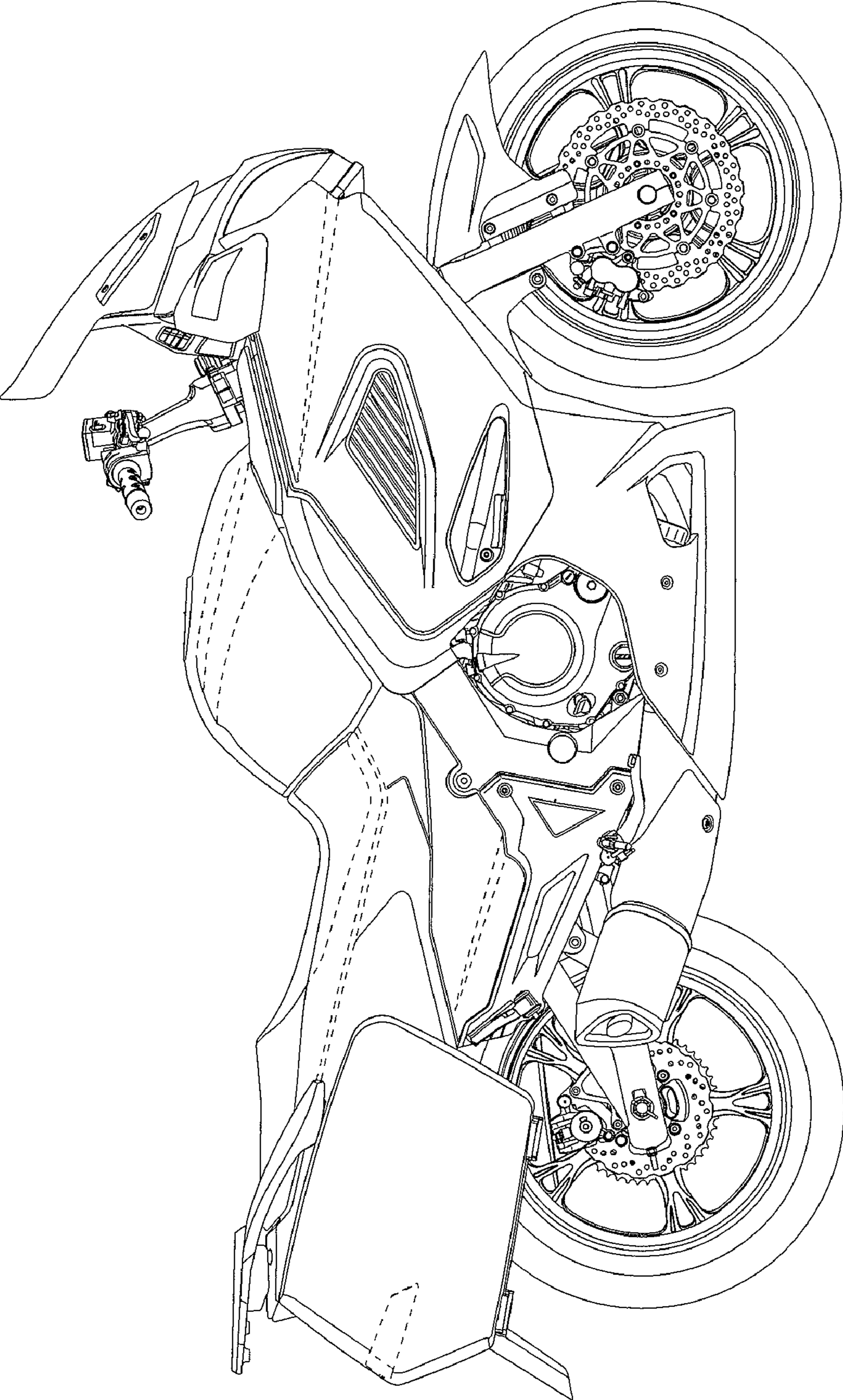

FIG. 2

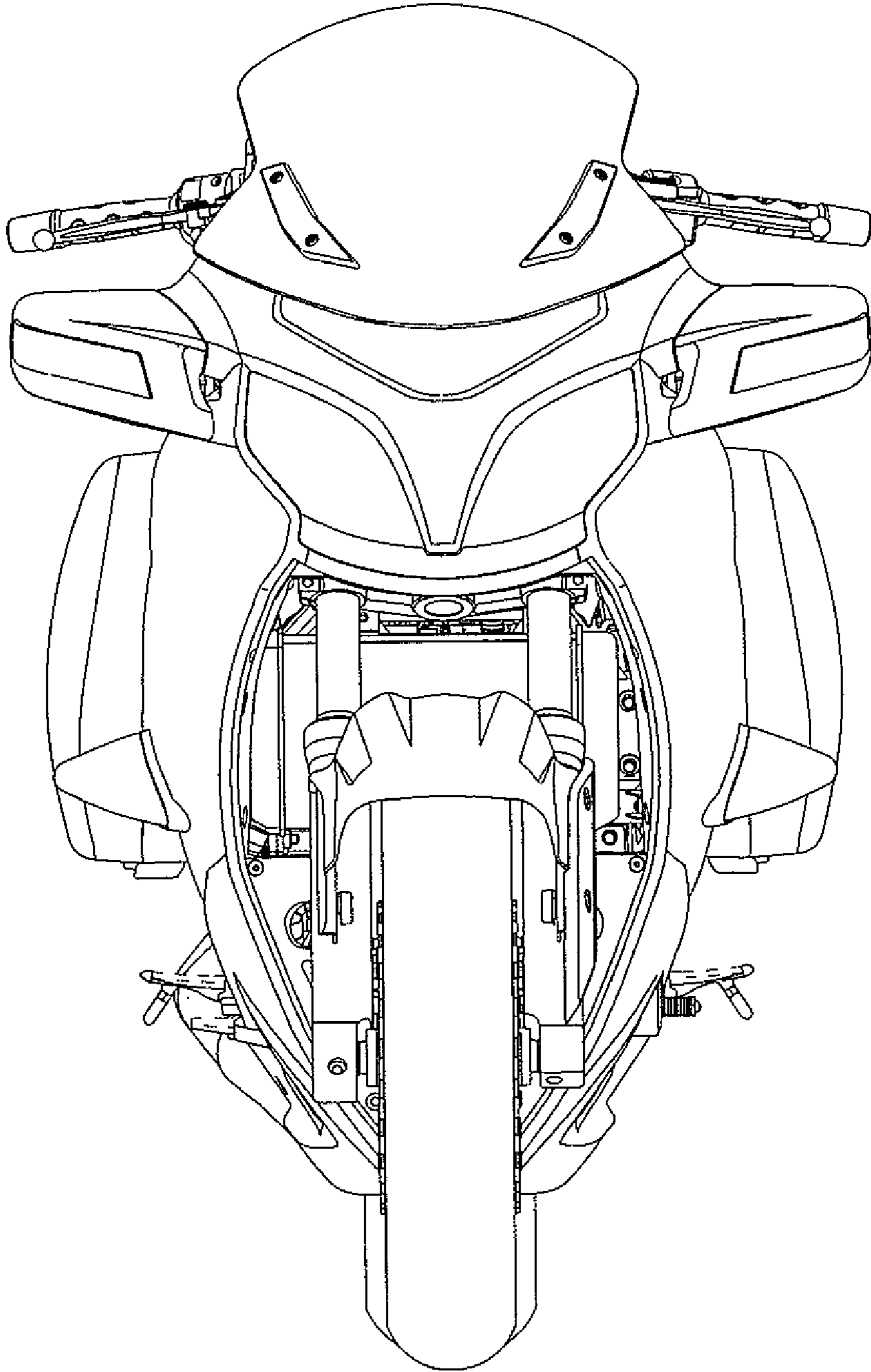

FIG. 3

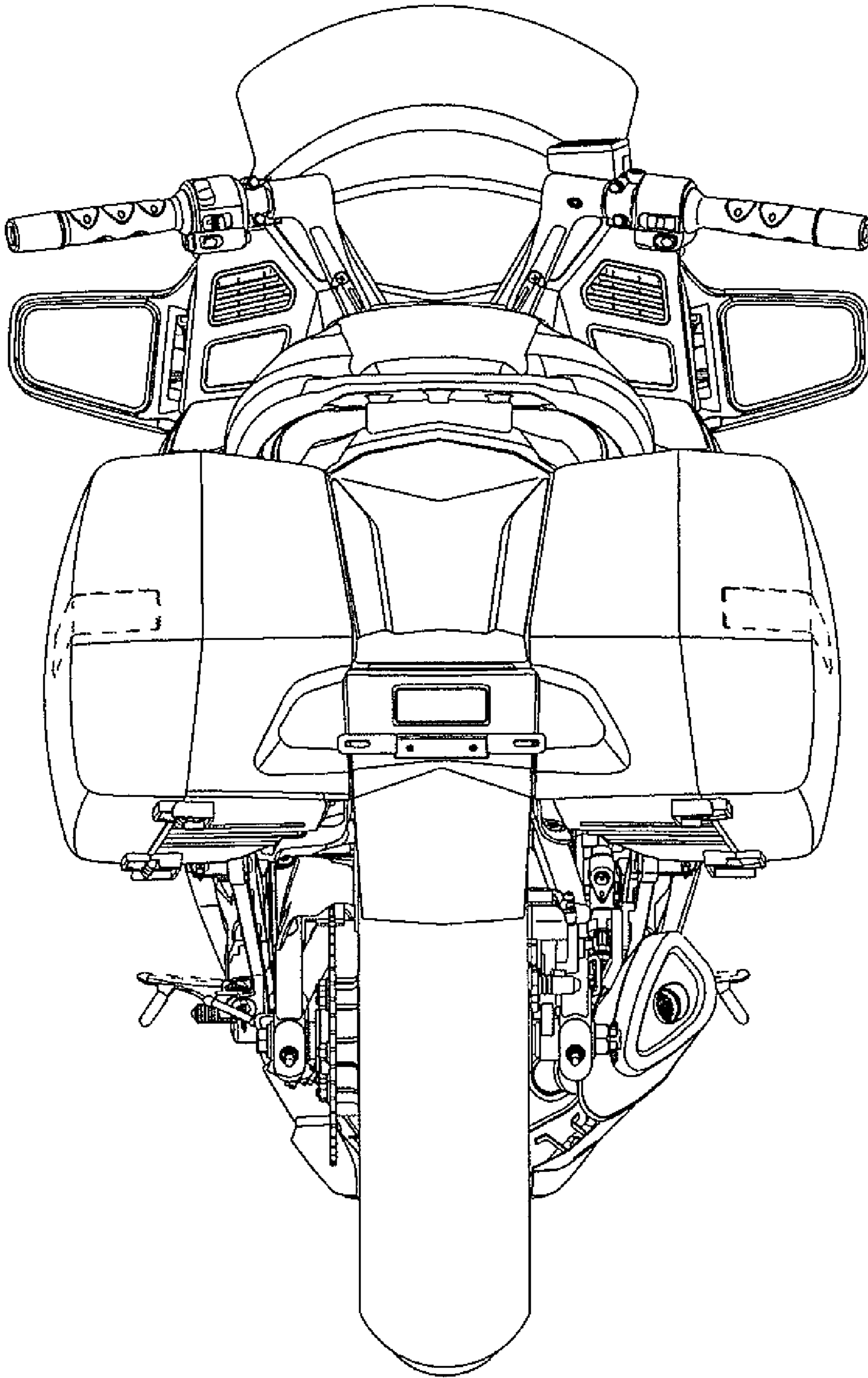

FIG. 4

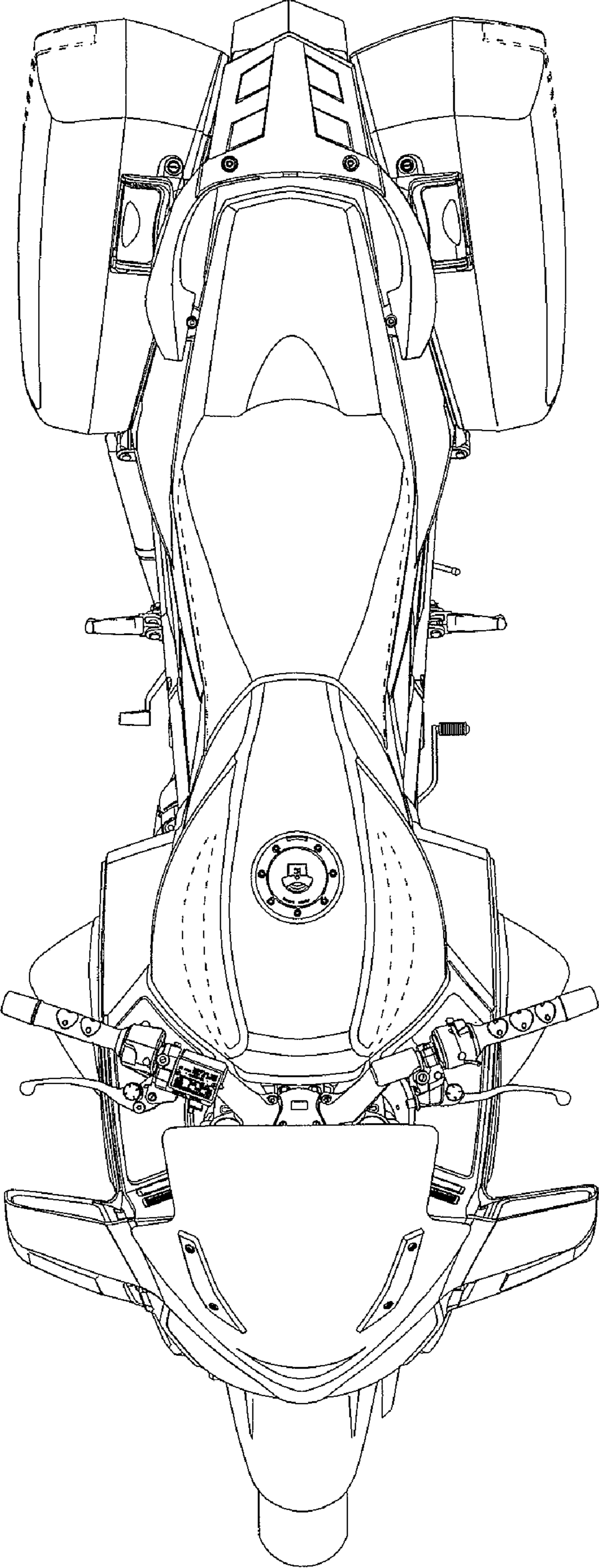

FIG. 5

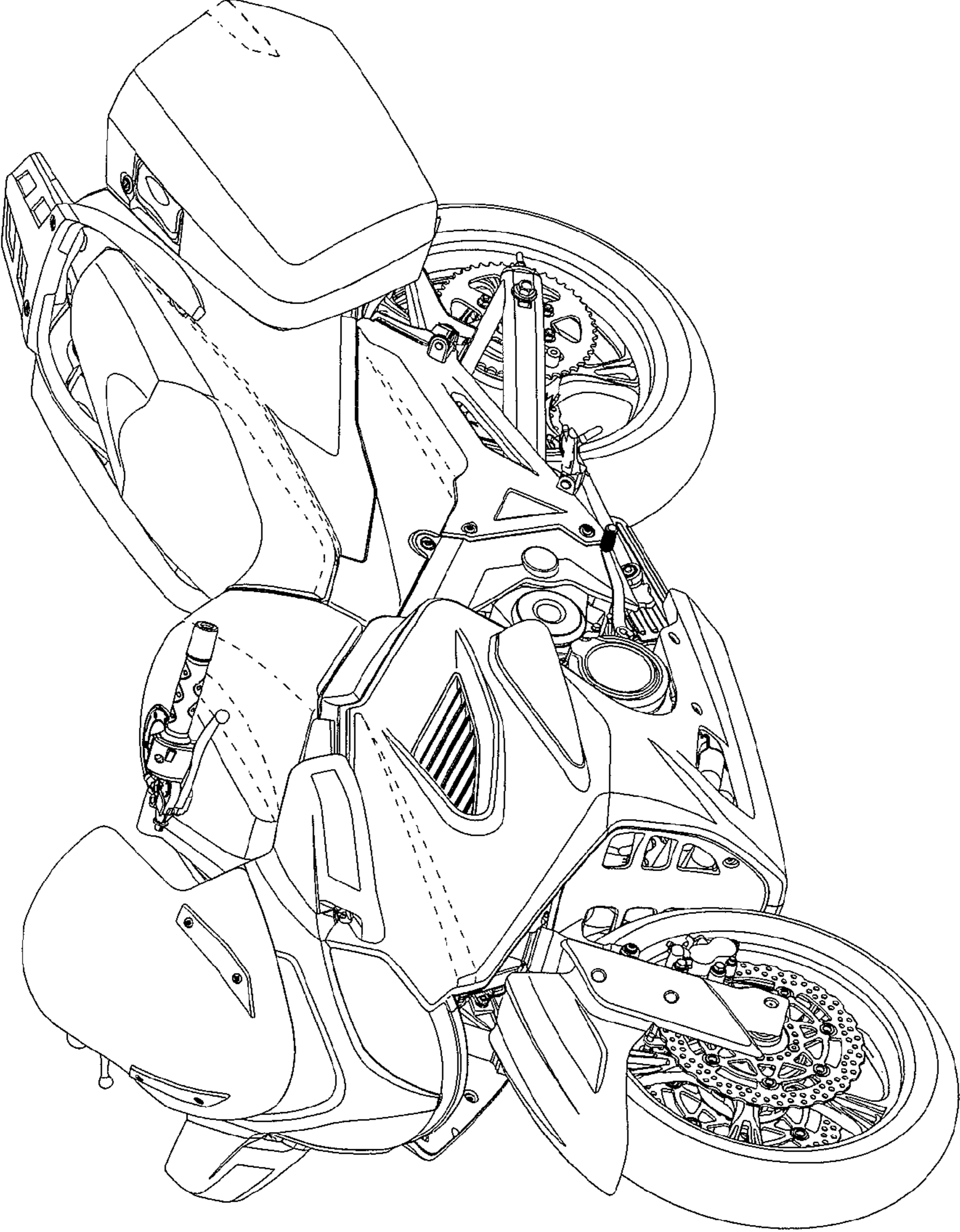

FIG. 6