



US00D640605S

(12) **United States Design Patent**  
**Lai et al.**

(10) **Patent No.:** **US D640,605 S**  
(45) **Date of Patent:** **\*\* Jun. 28, 2011**

(54) **ALL-TERRAIN VEHICLE**

(56) **References Cited**

(75) Inventors: **Guogui Lai**, Hangzhou (CN);  
**Xiangyang Zhu**, Hangzhou (CN);  
**Yongzhou Zhao**, Hangzhou (CN);  
**Zhangping Yuan**, Hangzhou (CN); **Hui**  
**Xu**, Hangzhou (CN); **Jinpin Zheng**,  
Hangzhou (CN); **Yonggang Cui**,  
Hangzhou (CN)

U.S. PATENT DOCUMENTS

D492,916 S \* 7/2004 Rondeau et al. .... D12/107  
D531,088 S \* 10/2006 Lin ..... D12/107  
D546,246 S \* 7/2007 Crepeau et al. .... D12/107  
7,743,864 B2 \* 6/2010 Tweet ..... 180/89.1

\* cited by examiner

*Primary Examiner* — Susan M Lee

*Assistant Examiner* — Linda G. Brooks

(73) Assignee: **Zhejiang CFMOTO Power Co., Ltd.**,  
Hangzhou, Zhejiang Province (CN)

(74) *Attorney, Agent, or Firm* — Wolf, Greenfield & Sacks,  
P.C.

(\*\*) Term: **14 Years**

(57) **CLAIM**

(21) Appl. No.: **29/368,051**

The ornamental design for an all-terrain vehicle, as shown  
and described.

(22) Filed: **Aug. 17, 2010**

**DESCRIPTION**

(30) **Foreign Application Priority Data**

Jul. 28, 2010 (CN) ..... 2010 3 0250791

(51) **LOC (9) Cl.** ..... **12-11**

(52) **U.S. Cl.** ..... **D12/107**

(58) **Field of Classification Search** ..... D12/107,  
D12/3, 86, 87, 110; 180/223, 225, 229, 233,  
180/311, 312, 315; 297/195.1, 215.1, 215.11,  
297/215.12, 452.48; D6/354

FIG. 1 is a front view of the all-terrain vehicle;  
FIG. 2 is a back view of the all-terrain vehicle;  
FIG. 3 is a left view of the all-terrain vehicle;  
FIG. 4 is a right view of the all-terrain vehicle;  
FIG. 5 is a top view of the all-terrain vehicle; and,  
FIG. 6 is a perspective view of the all-terrain vehicle.  
The bottom view of the all-terrain vehicle is not generally  
seen, and thus omitted therein.

See application file for complete search history.

**1 Claim, 5 Drawing Sheets**

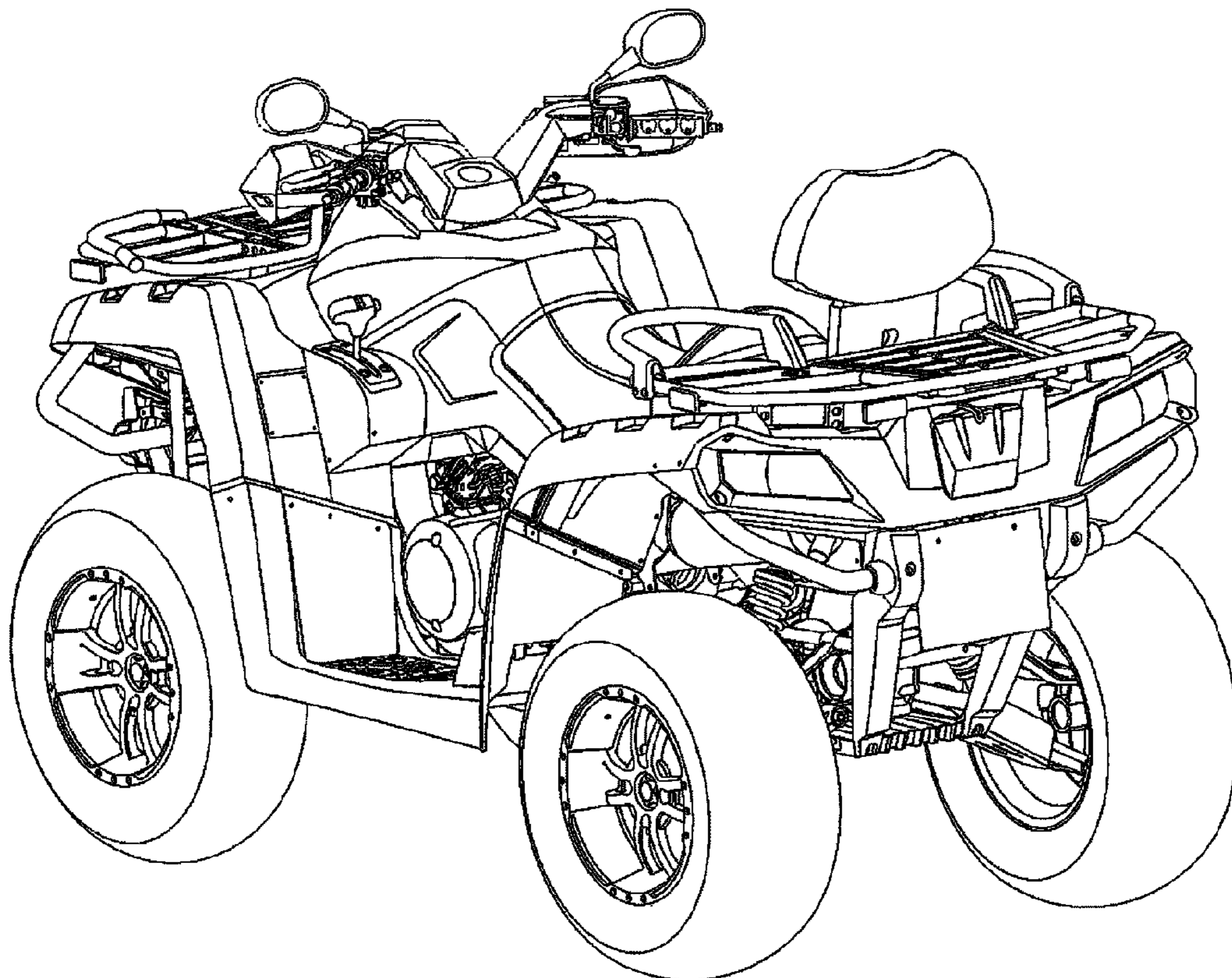

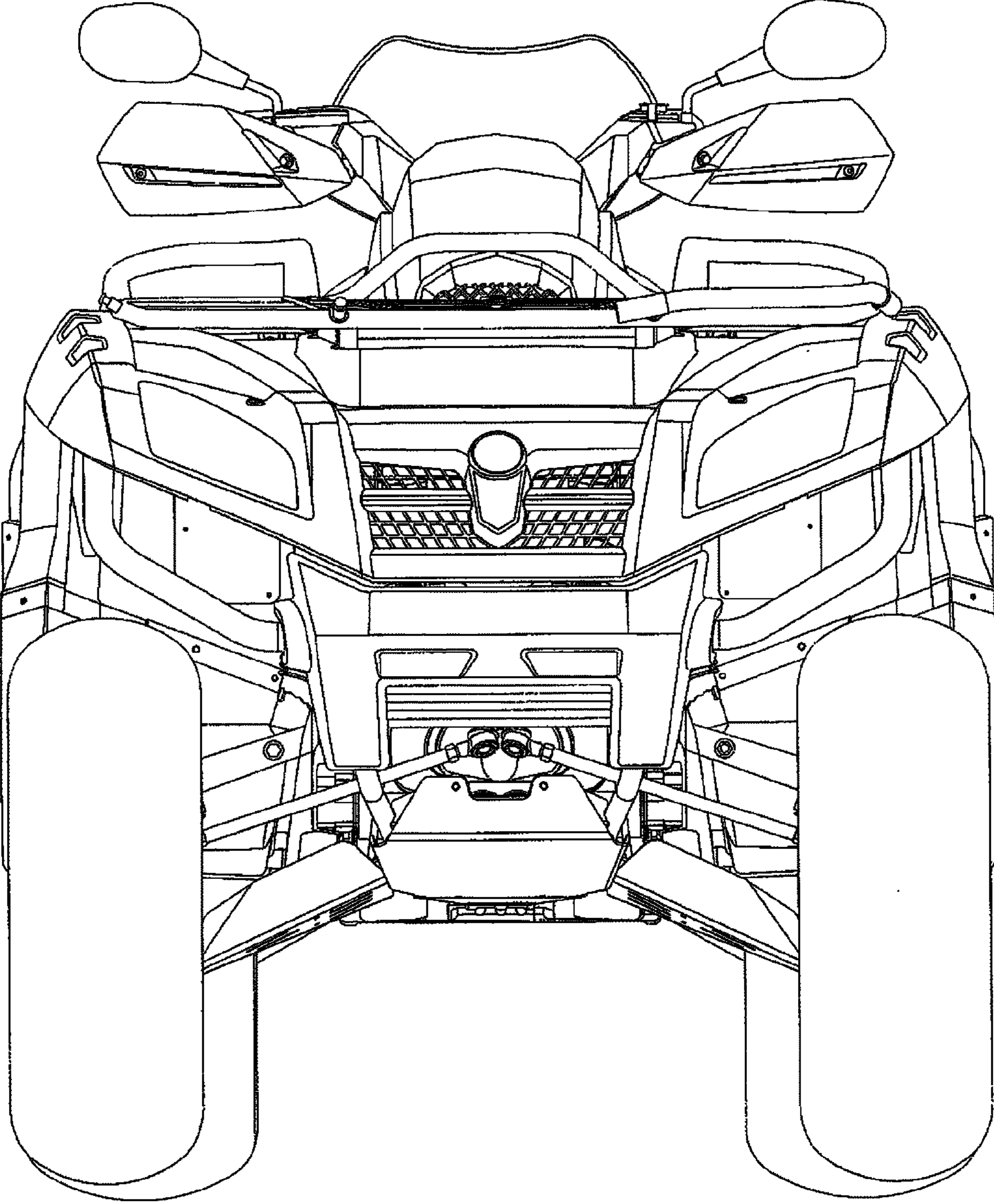
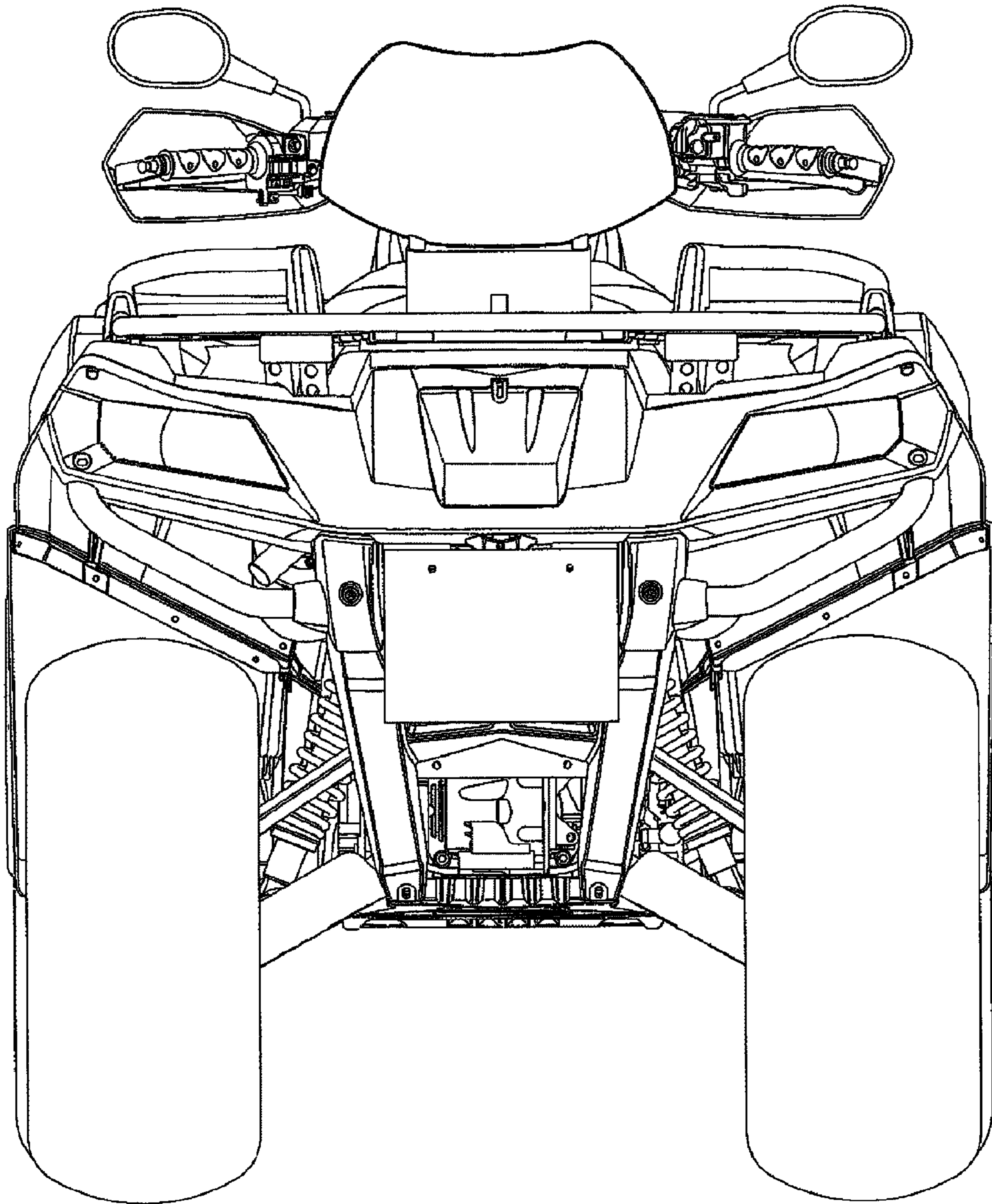

Fig. 1



**Fig. 2**

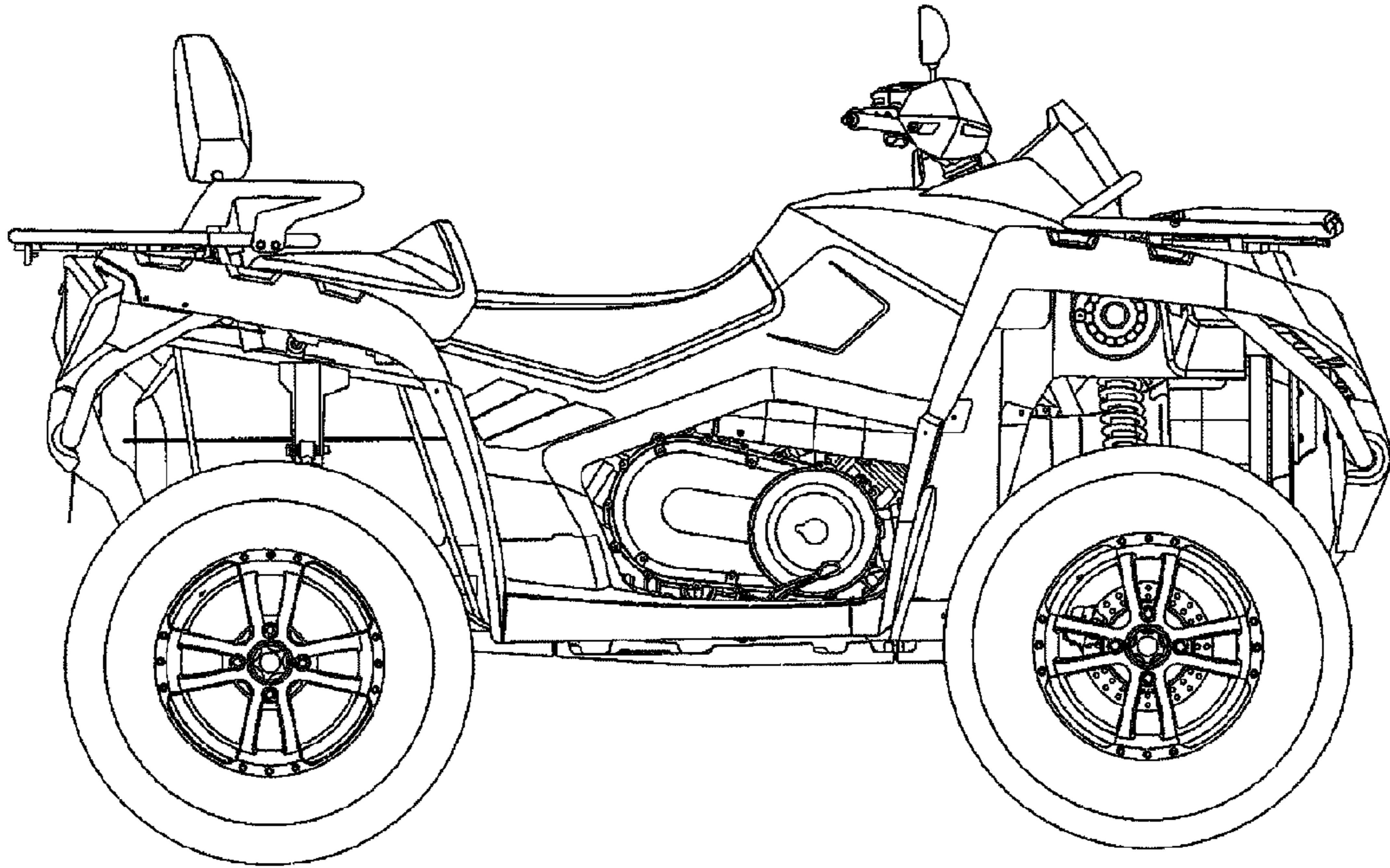

Fig. 3

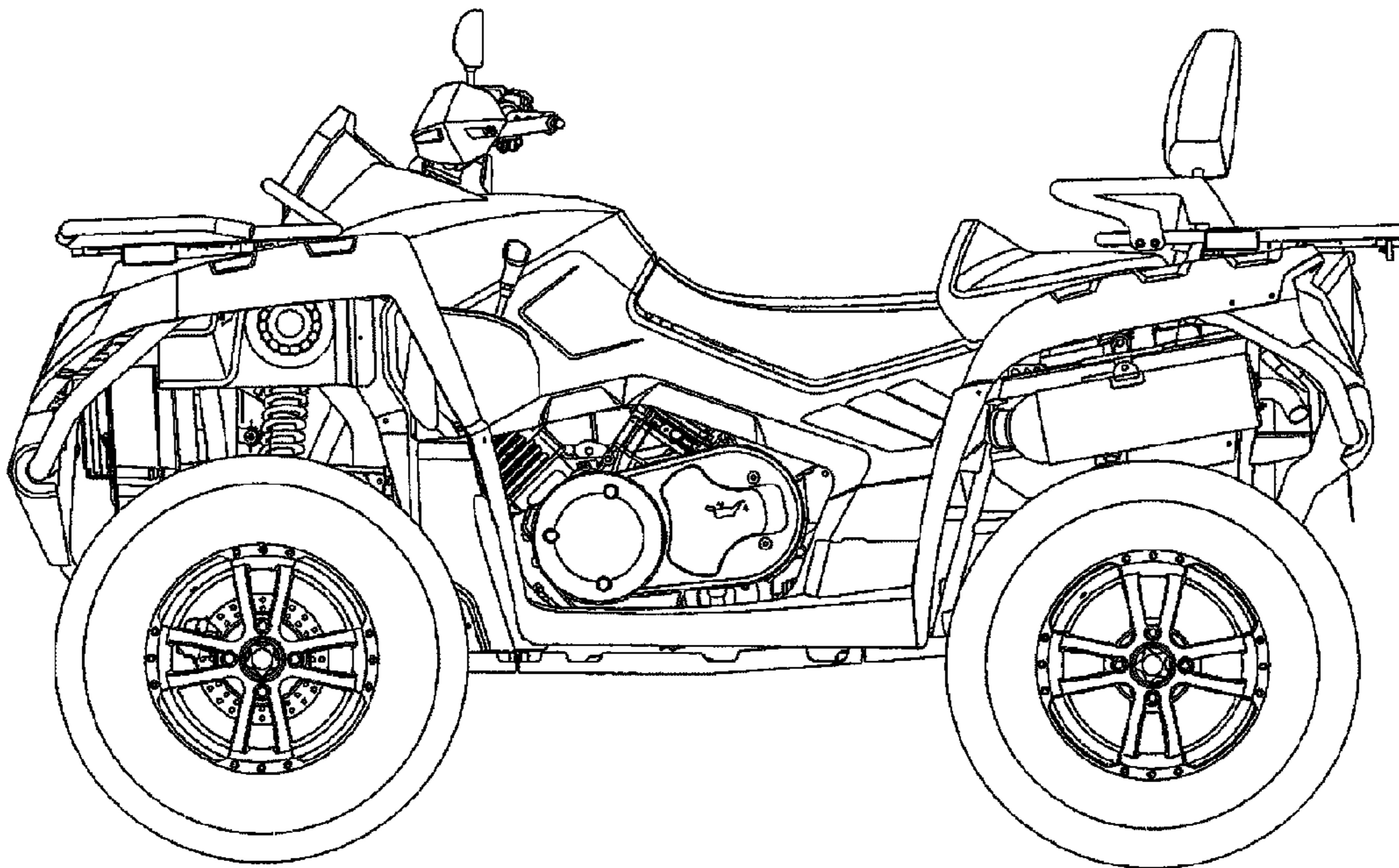

Fig. 4

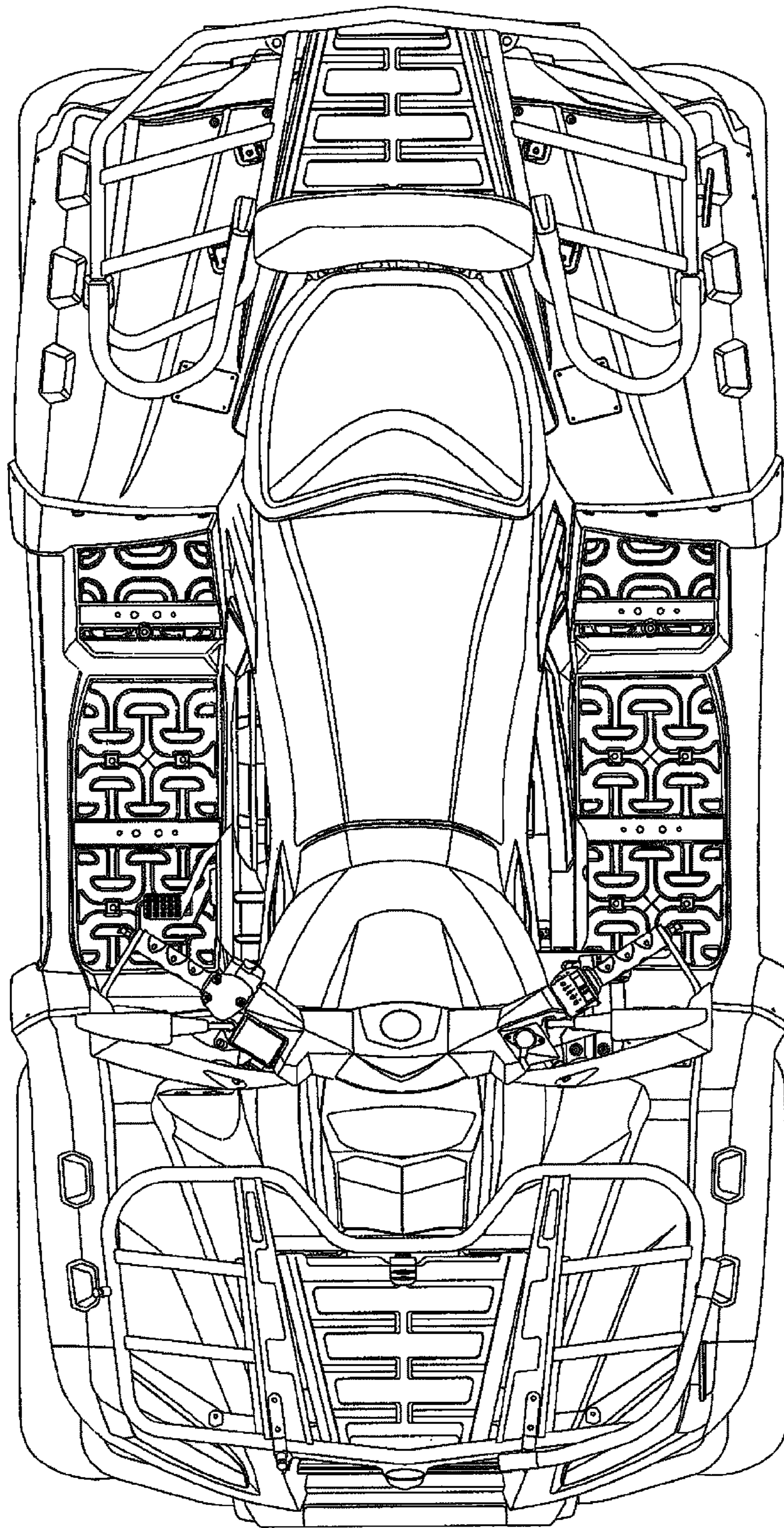
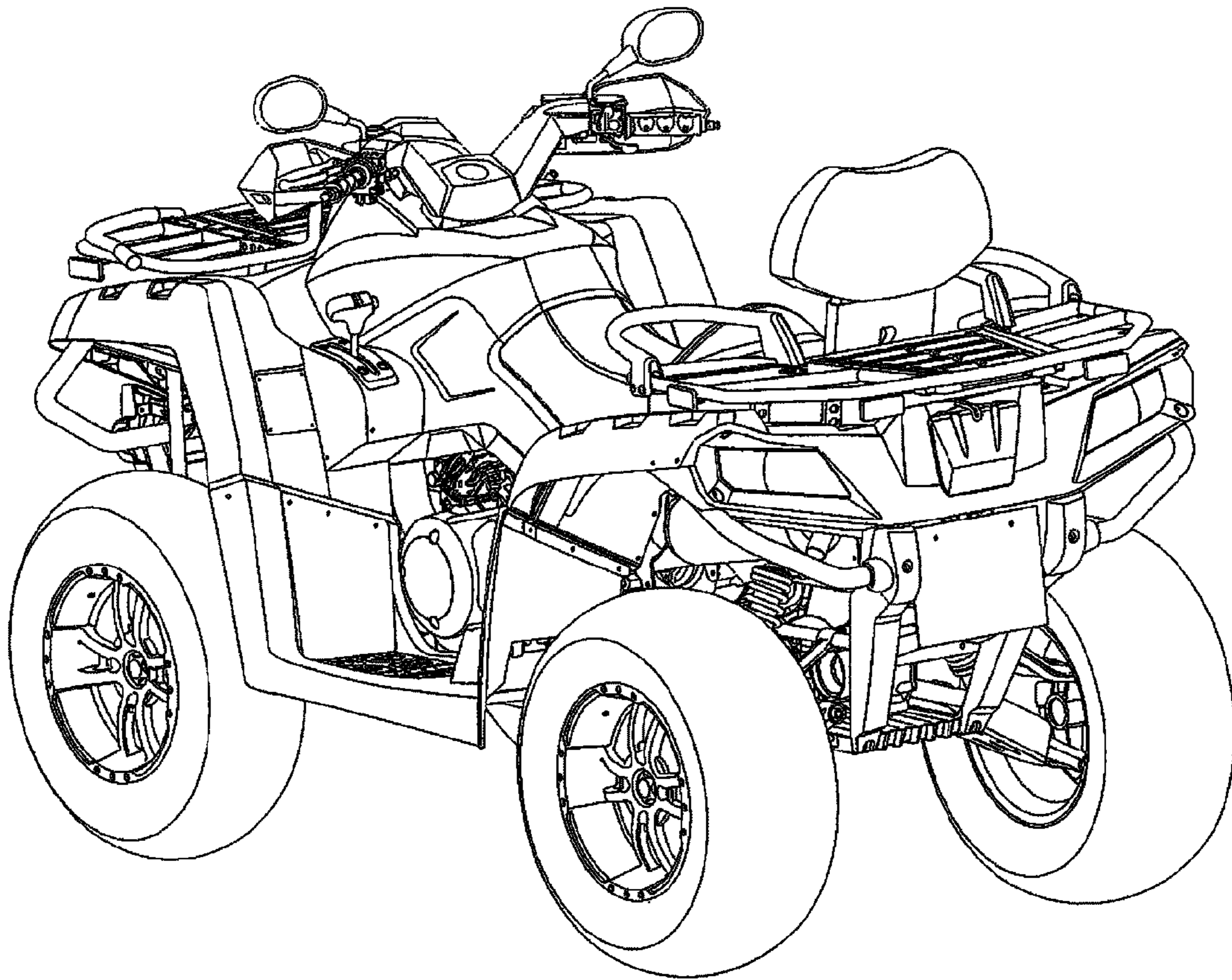

Fig. 5



**Fig. 6**