



US00D640520S

(12) **United States Design Patent**  
**Rampling**

(10) **Patent No.:** **US D640,520 S**

(45) **Date of Patent:** **\*\* Jun. 28, 2011**

(54) **CUTTING DEVICE**

(75) **Inventor:** **Scott Rampling**, Marlow (GB)

(73) **Assignee:** **Scott Cutters UK Limited**,  
Buckinghamshire (GB)

(\*\*) **Term:** **14 Years**

(21) **Appl. No.:** **29/352,223**

(22) **Filed:** **Dec. 17, 2009**

(30) **Foreign Application Priority Data**

Jun. 18, 2009 (EM) ..... 1552555-002

(51) **LOC (9) Cl.** ..... **08-03**

(52) **U.S. Cl.** ..... **D8/60**

(58) **Field of Classification Search** ..... D8/51,  
D8/57, 60, 107, 312, 14, 41, 98; 30/92, 93,  
30/94, 95, 96, 97, 101, 102

See application file for complete search history.

(56) **References Cited**

**U.S. PATENT DOCUMENTS**

3,335,492	A *	8/1967	Spiro	.....	30/101
4,831,732	A *	5/1989	Garton	.....	30/101
D309,563	S *	7/1990	Astle	.....	D8/60
D312,953	S *	12/1990	Vanderpol et al.	.....	D8/60
5,285,576	A *	2/1994	Taylor	.....	30/94
6,154,963	A *	12/2000	Kooiman	.....	30/90.2
D446,103	S *	8/2001	Olaneta	.....	D8/98

D459,963	S *	7/2002	Usbeck	.....	D8/41
D464,244	S *	10/2002	Lira-Nunez et al.	.....	D8/98
6,739,055	B2 *	5/2004	Lee	.....	30/98
7,007,391	B2 *	3/2006	Stoick et al.	.....	30/101
D556,528	S *	12/2007	Huang	.....	D8/60
D605,011	S *	12/2009	Jalet	.....	D8/41
2004/0025351	A1 *	2/2004	Lee	.....	30/101
2005/0086809	A1 *	4/2005	Myers	.....	30/101
2005/0274022	A1 *	12/2005	Korczak et al.	.....	30/93
2005/0274023	A1 *	12/2005	Huang	.....	30/97
2007/0050984	A1 *	3/2007	Bartoluzzi	.....	30/93
2007/0180701	A1 *	8/2007	Hutt	.....	30/95

\* cited by examiner

*Primary Examiner* — Cathron Brooks

*Assistant Examiner* — Deanna Fluegeman

(74) *Attorney, Agent, or Firm* — Christie, Parker & Hale, LLP

(57) **CLAIM**

The ornamental design for a cutting device, as shown and described.

**DESCRIPTION**

FIG. 1 is a perspective view of the cutting device in a closed position;

FIG. 2 is a left side view thereof;

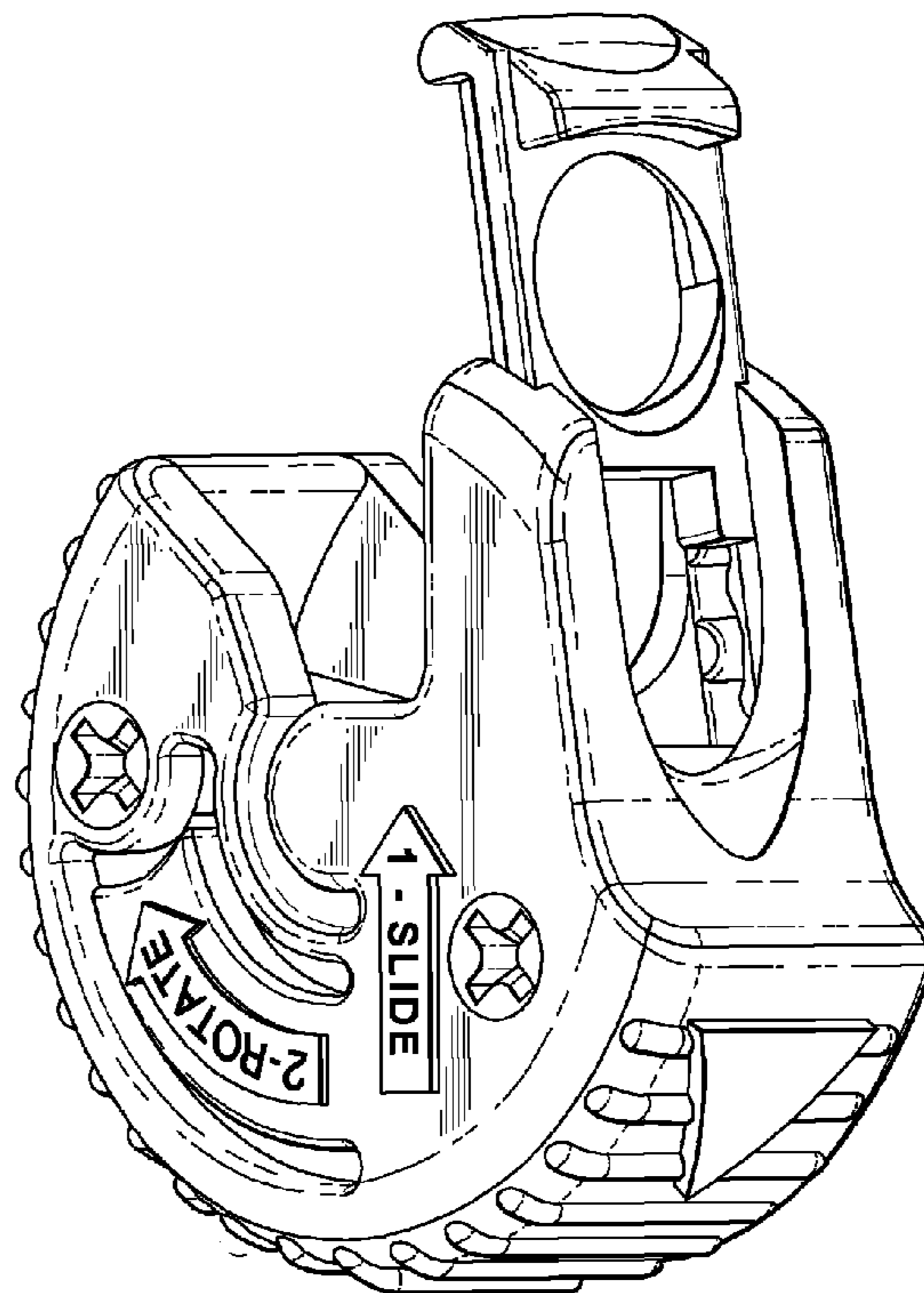
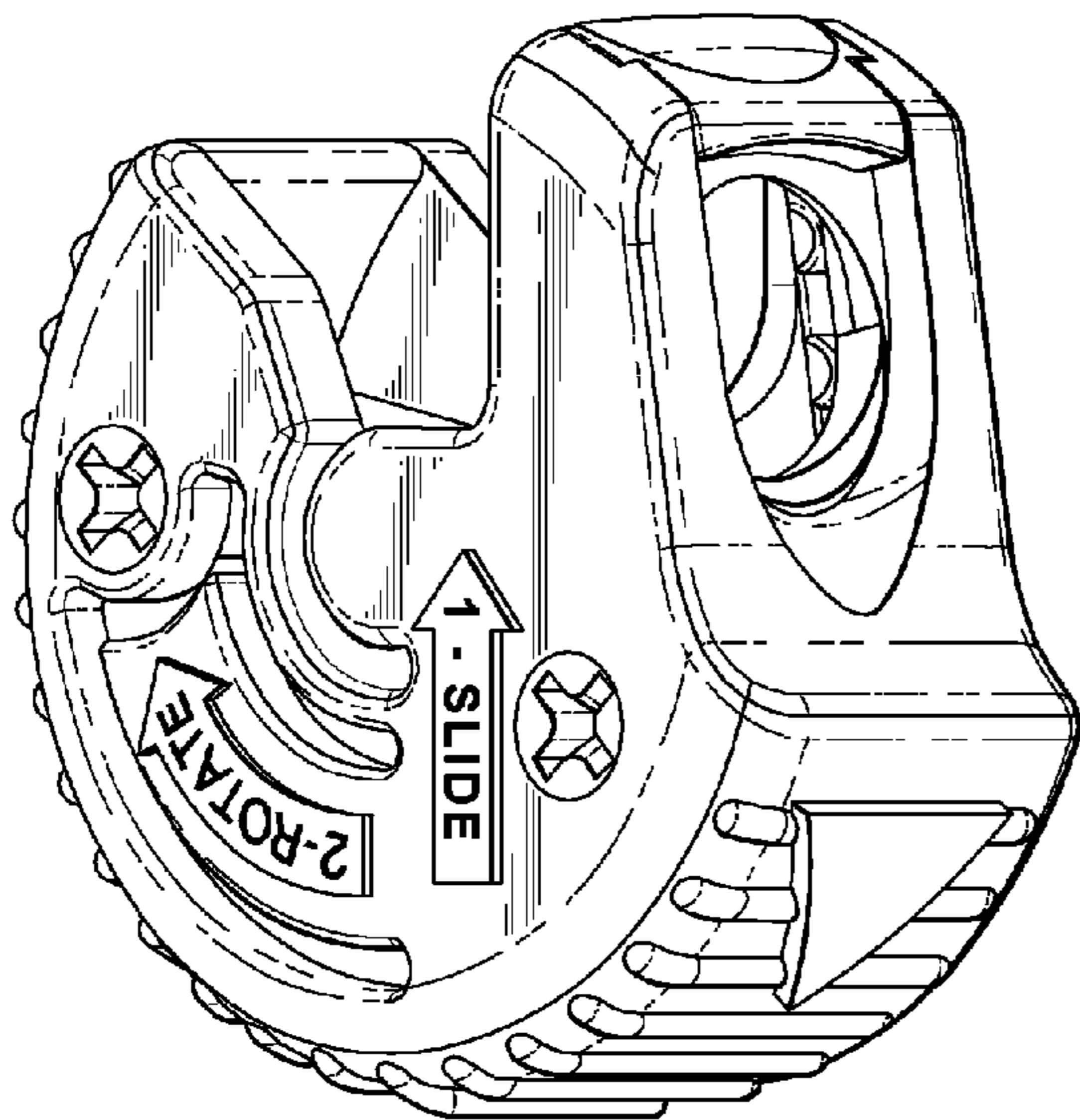
FIG. 3 is a right side view thereof;

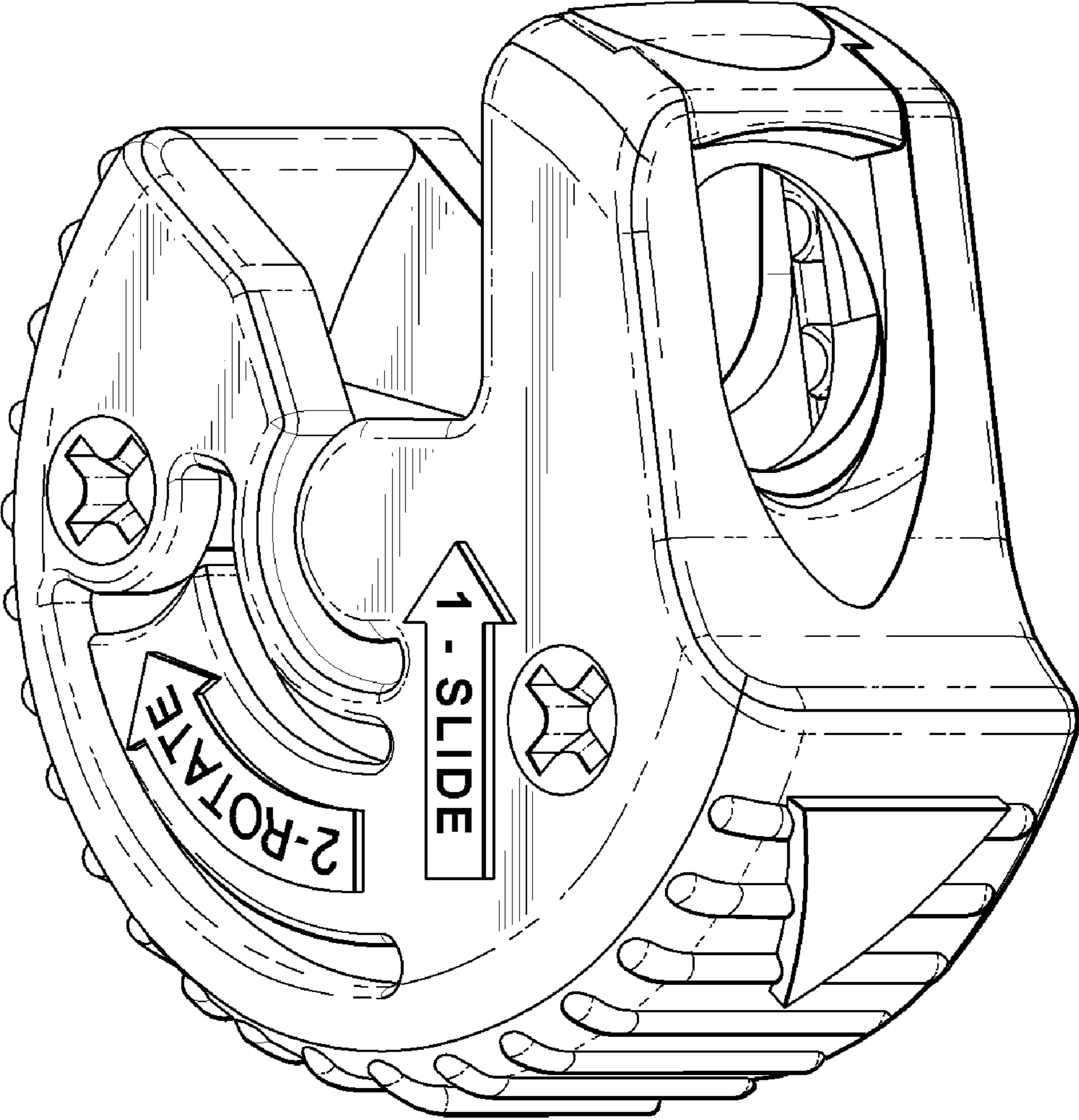
FIG. 4 is a top view thereof;

FIG. 5 is a bottom view thereof; and,

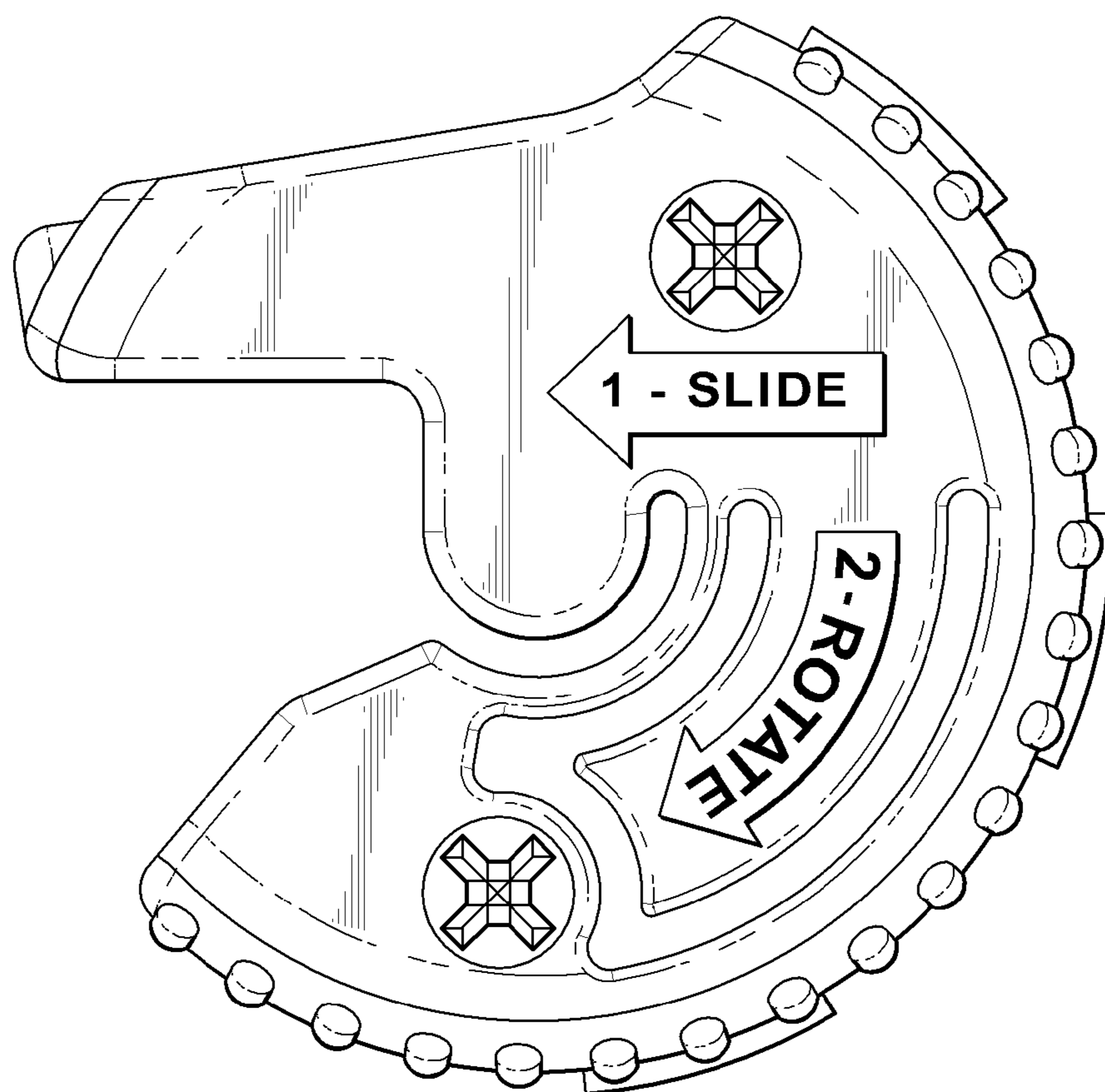
FIG. 6 is a perspective view of the cutting device shown in an open position.

**1 Claim, 6 Drawing Sheets**

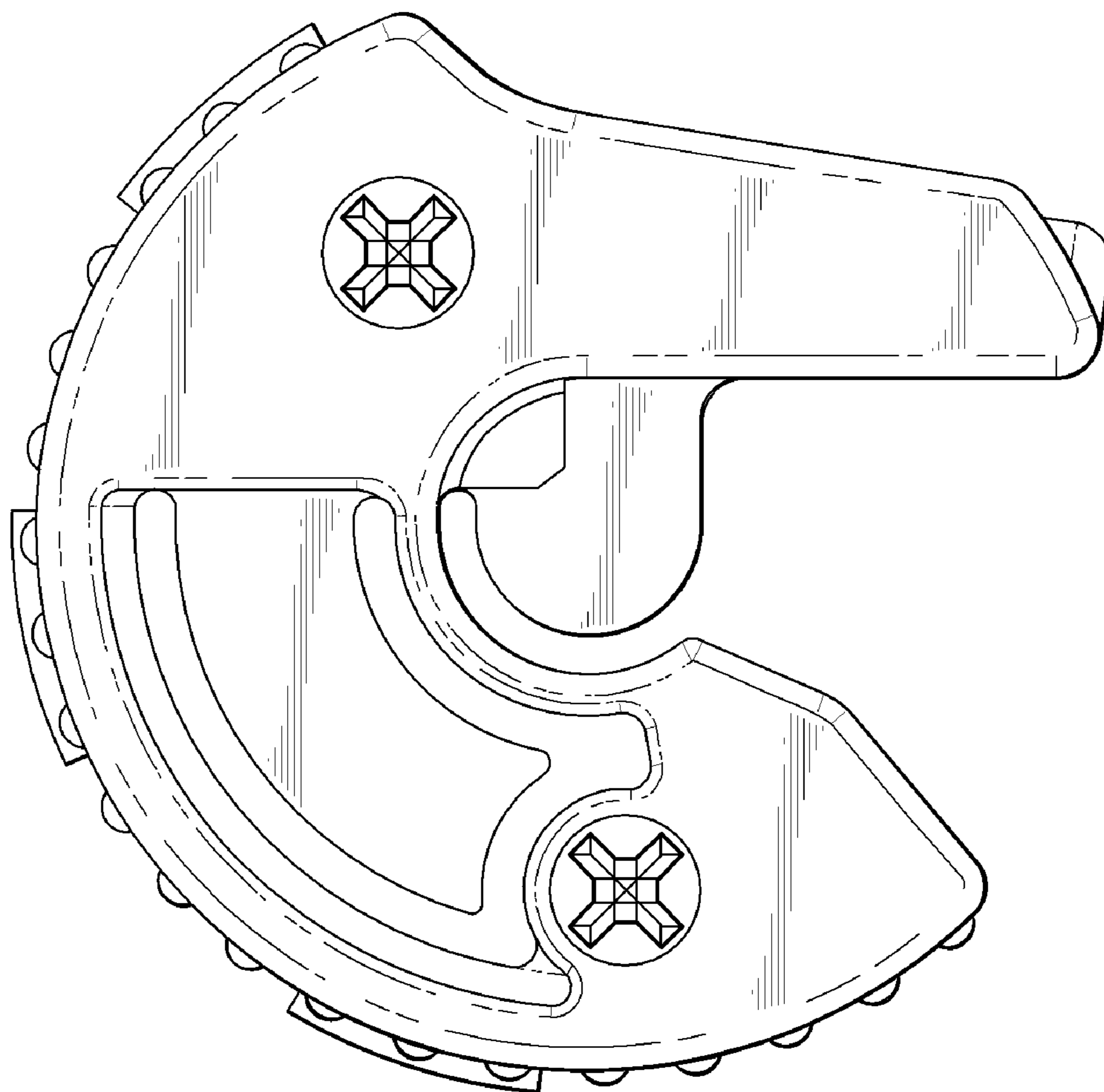




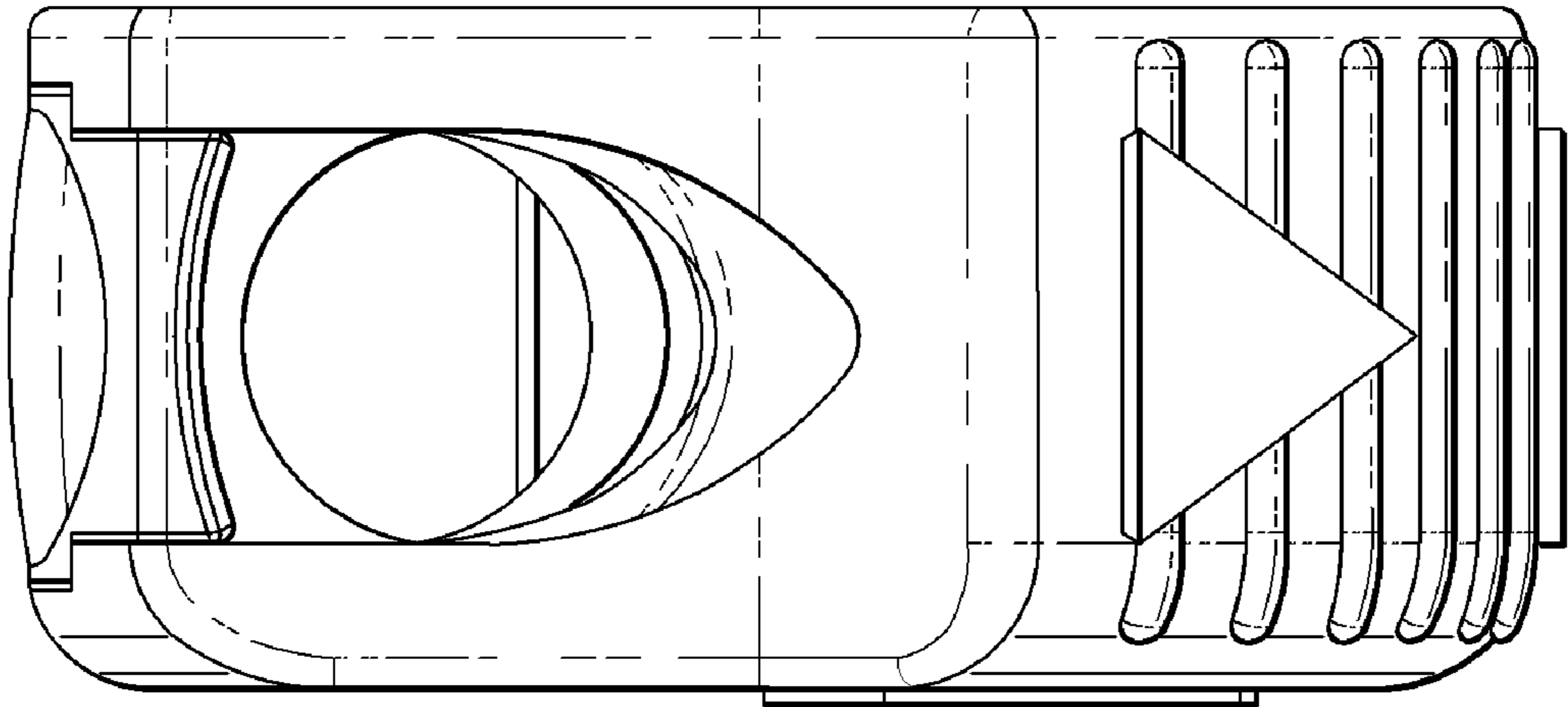
**FIG. 1**



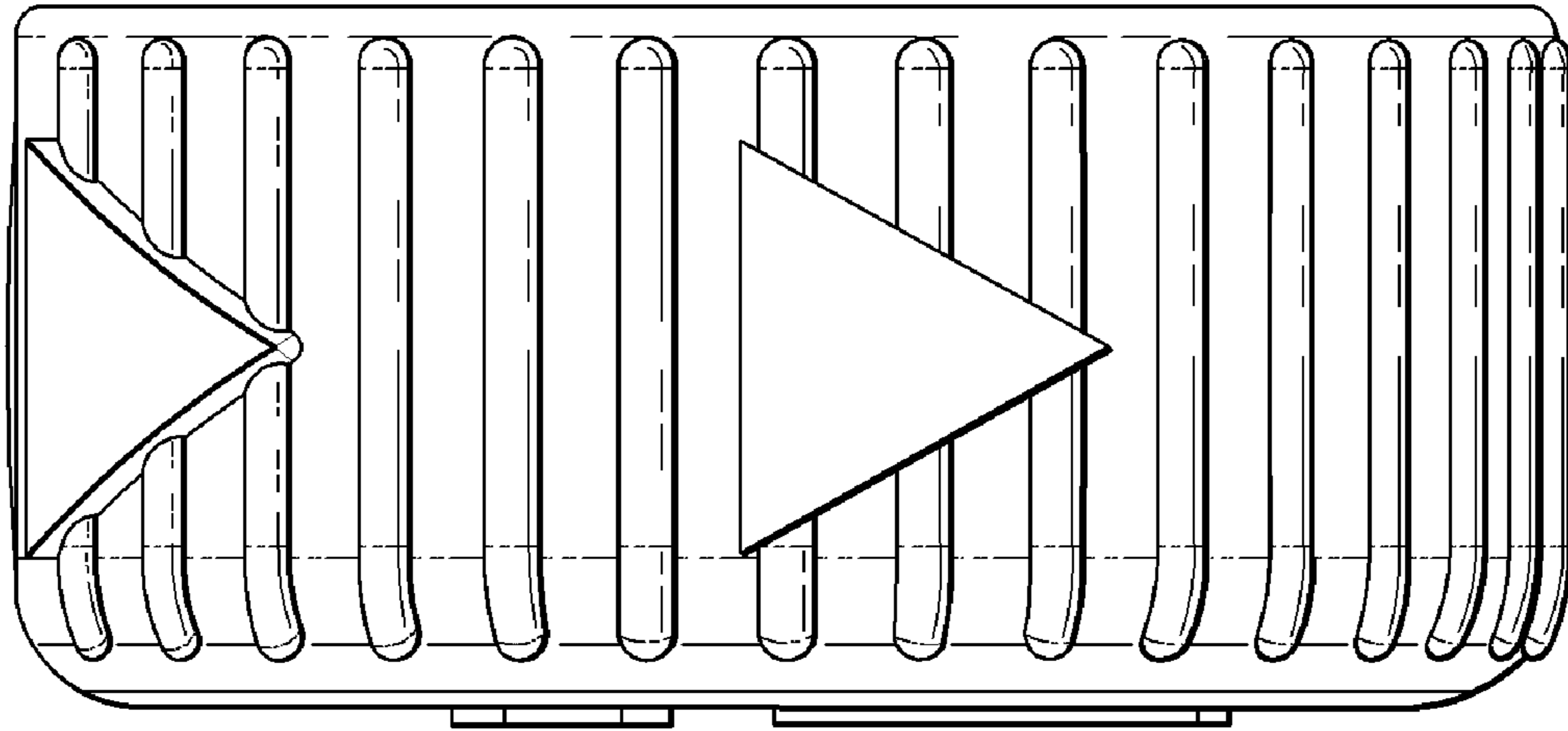
*FIG. 2*



**FIG. 3**



*FIG. 4*



*FIG. 5*

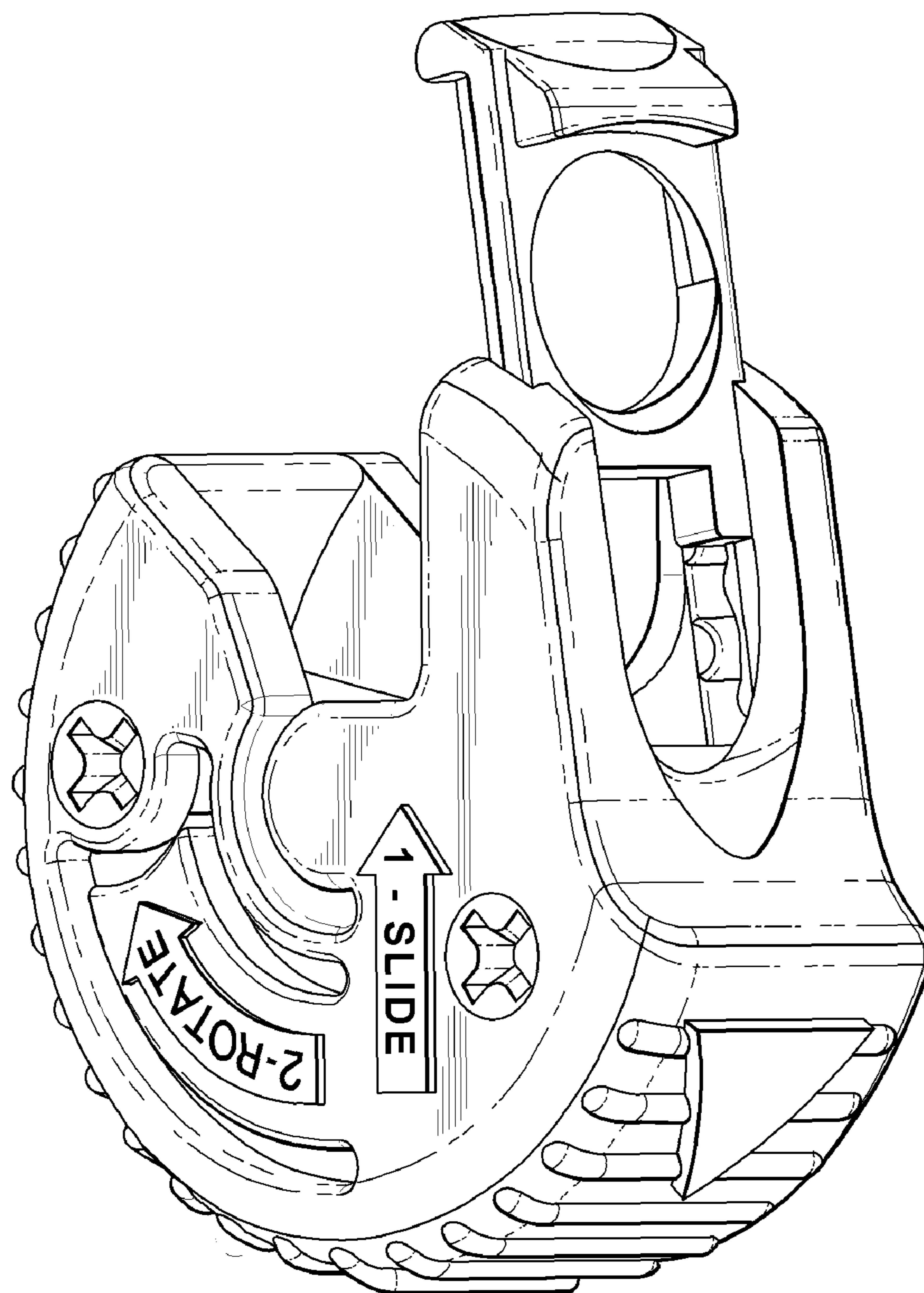


FIG. 6