



US00D640331S

(12) **United States Design Patent**
Beauregard et al.

(10) **Patent No.:** **US D640,331 S**
(45) **Date of Patent:** **** Jun. 21, 2011**

- (54) **TOY VEHICLE TRACK RAMP**
- (75) Inventors: **Thierry Beauregard**, Boisbriand (CA);
Patrice Paquette, Melbourne (CA)
- (73) Assignee: **MEGA Brands Inc.**, Montreal, Quebec (CA)
- (**) Term: **14 Years**
- (21) Appl. No.: **29/379,296**
- (22) Filed: **Nov. 17, 2010**
- (51) **LOC (9) Cl.** **21-01**
- (52) **U.S. Cl.** **D21/565**
- (58) **Field of Classification Search** D21/484,
D21/490, 493, 564, 565, 802, 818, 821;
446/168–174, 84, 89, 108, 112, 114, 116,
446/124–128, 429, 444–447; 463/58–69;
238/10 R, 10 A–10 C, 10 E, 10 F; 104/60,
104/69

See application file for complete search history.

(56) **References Cited**

U.S. PATENT DOCUMENTS

- D195,679 S * 7/1963 Genin et al. D21/565
- 3,464,624 A 9/1969 Christiansen
- 3,559,334 A * 2/1971 Beny et al. 446/445
- 3,583,631 A 6/1971 Christiansen
- D258,225 S * 2/1981 Rawson D21/565
- D261,292 S 10/1981 Tong
- 4,403,733 A 9/1983 Bach et al.
- D281,002 S 10/1985 Olsen
- D281,443 S 11/1985 Olsen
- D285,224 S * 8/1986 Olsen D21/493
- D296,803 S 7/1988 Bach et al.
- D296,804 S 7/1988 Bach et al.
- D296,805 S 7/1988 Mikkelsen
- D296,806 S 7/1988 Bach et al.
- 4,861,306 A 8/1989 Bolli et al.
- D304,048 S * 10/1989 Freese D21/483
- D309,641 S * 7/1990 Olsen D21/494
- D314,996 S 2/1991 Olsen
- 5,087,001 A 2/1992 Bolli et al.
- D325,057 S 3/1992 Plagborg
- D326,880 S 6/1992 Larsen

- D330,743 S * 11/1992 Mercer D21/818
- D332,642 S 1/1993 Pagel
- D344,306 S 2/1994 Ruskai
- D344,307 S 2/1994 Ruskai
- D344,308 S 2/1994 Ruskai
- D344,309 S 2/1994 Ruskai
- D344,310 S 2/1994 Ruskai
- D344,554 S 2/1994 Ruskai
- D344,555 S 2/1994 Ruskai
- D344,992 S 3/1994 Ruskai
- D357,714 S 4/1995 Ryaa
- 5,564,962 A * 10/1996 Navarrete Espinosa 446/128
- 5,657,695 A 8/1997 Lanoix et al.
- D388,138 S 12/1997 Lanoix et al.
- D409,690 S 5/1999 Nielsen
- D409,691 S 5/1999 Harms
- D410,059 S * 5/1999 Zeilinger D21/818
- D411,594 S * 6/1999 Harms D21/564
- D412,949 S 8/1999 Nielsen
- 6,342,015 B1 * 1/2002 Robertson et al. 472/116
- 6,616,500 B1 9/2003 Harms et al.
- D520,590 S * 5/2006 Zeilinger et al. D21/818
- D598,506 S * 8/2009 Schieltz D21/561

* cited by examiner

Primary Examiner — Cynthia M Chin

(74) *Attorney, Agent, or Firm* — Plumsea Law Group, LLC

(57) **CLAIM**

We claim the ornamental design for a toy vehicle track ramp, as shown and described.

DESCRIPTION

FIG. 1 is a top perspective view of the toy vehicle track ramp; FIG. 2 is a front elevational view thereof; FIG. 3 is a rear elevational view thereof; FIG. 4 is a left side elevational view thereof; FIG. 5 is a right side elevational view thereof; FIG. 6 is a top plan view thereof; FIG. 7 is a bottom plan view thereof; and, FIG. 8 is a bottom perspective view thereof. The broken or dashed lines shown are included for the purpose of illustrating the unclaimed portions of the article and form no part of the claimed design.

1 Claim, 5 Drawing Sheets

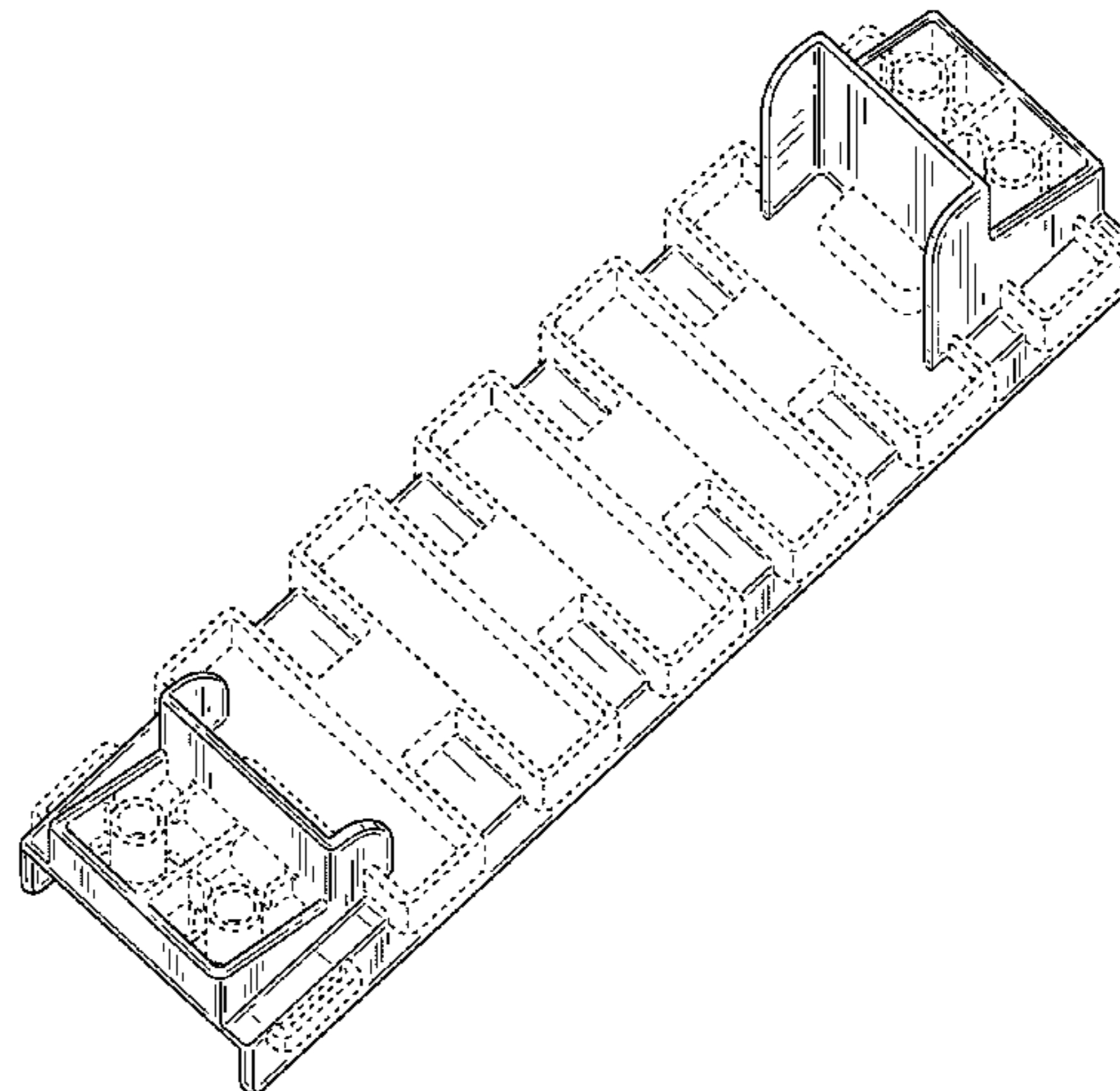
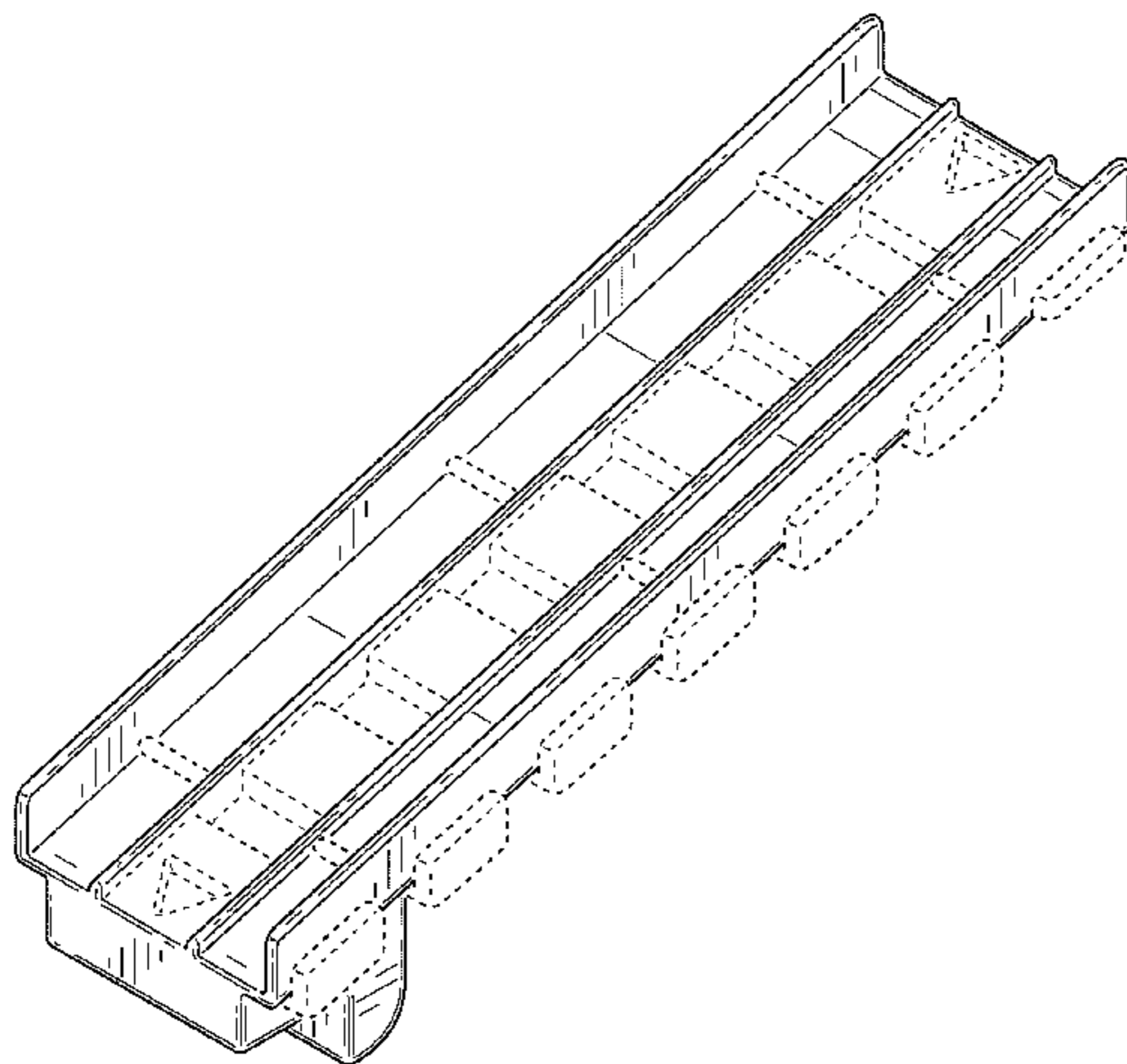

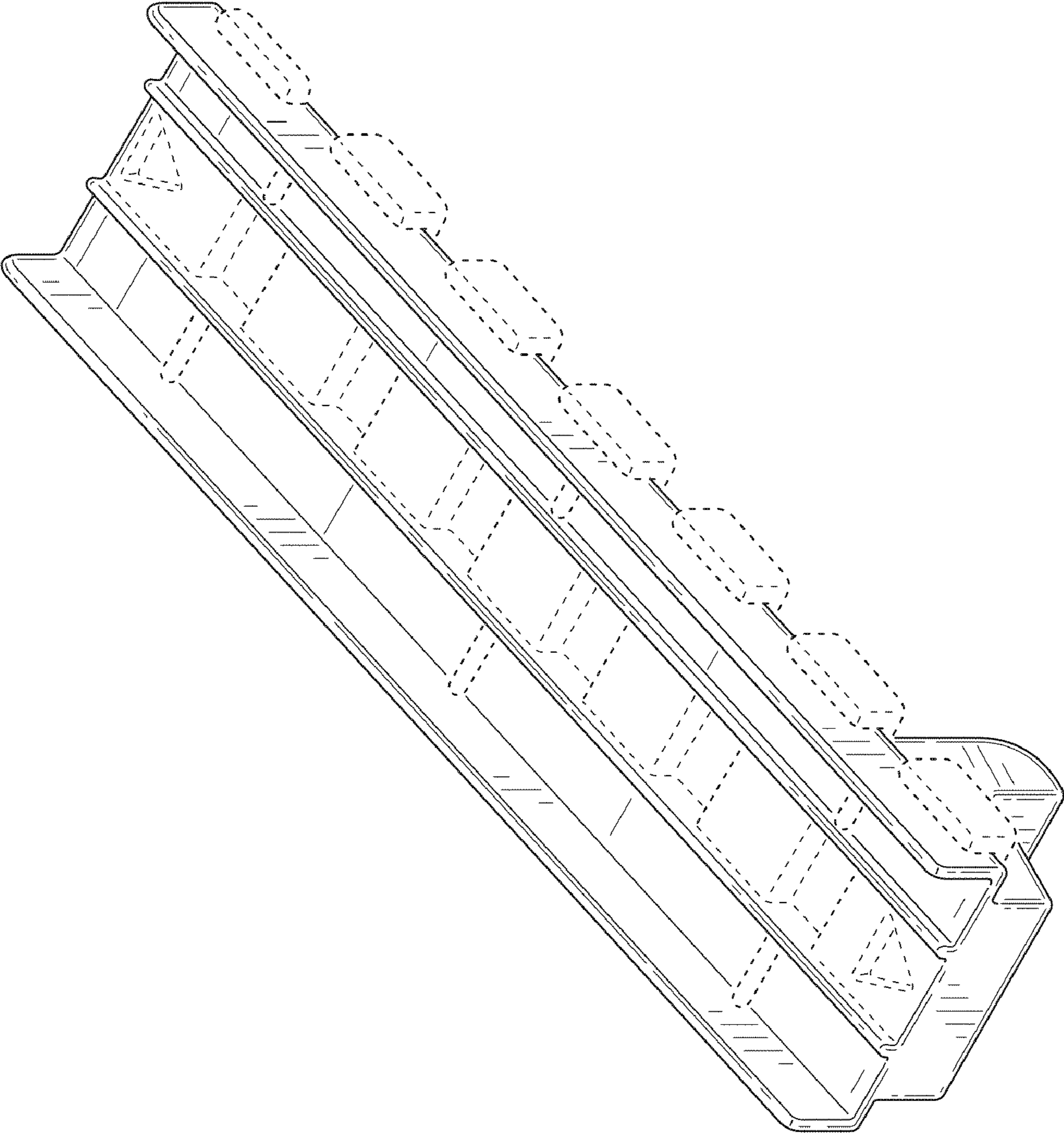

Fig. 1

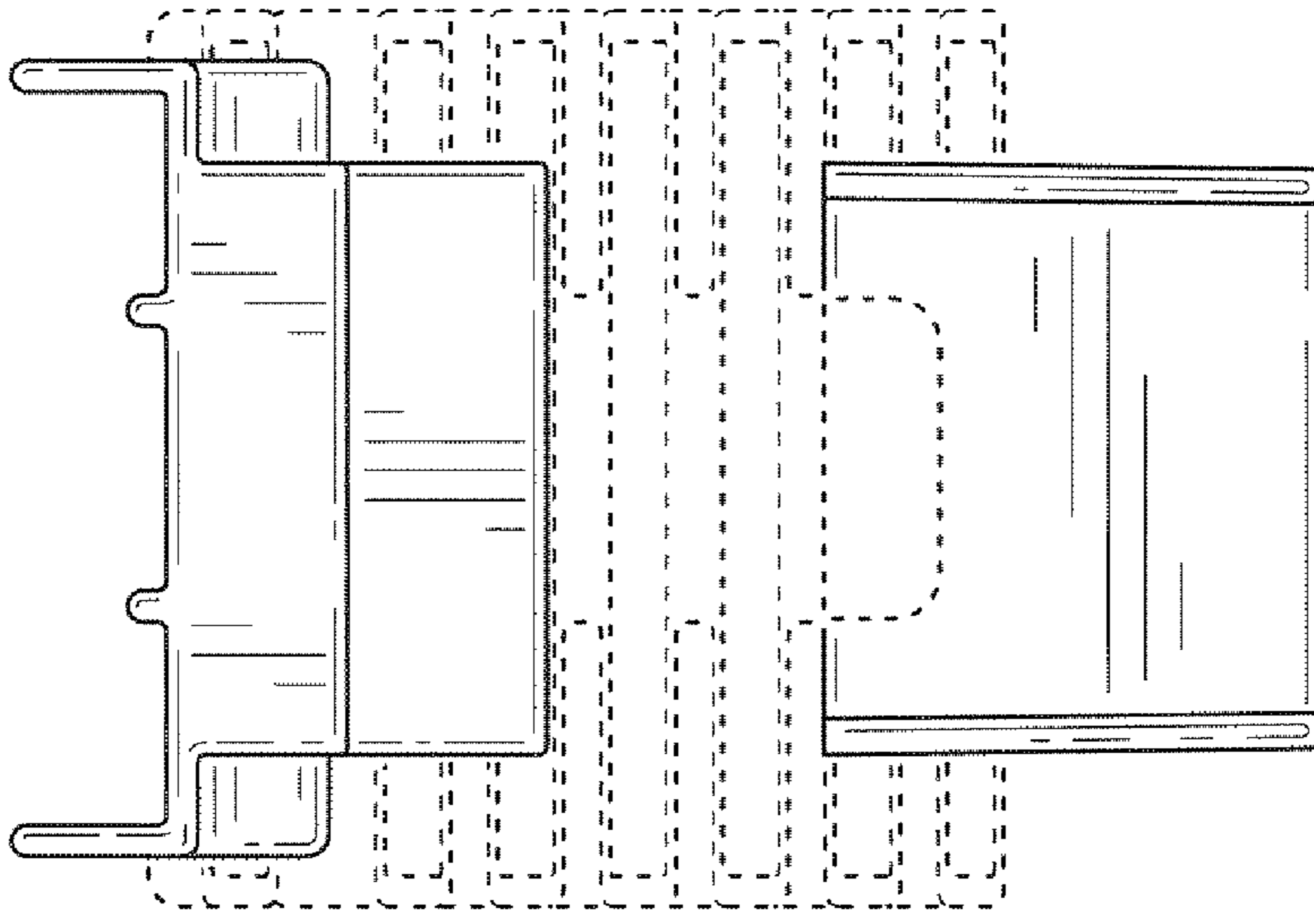

Fig. 2

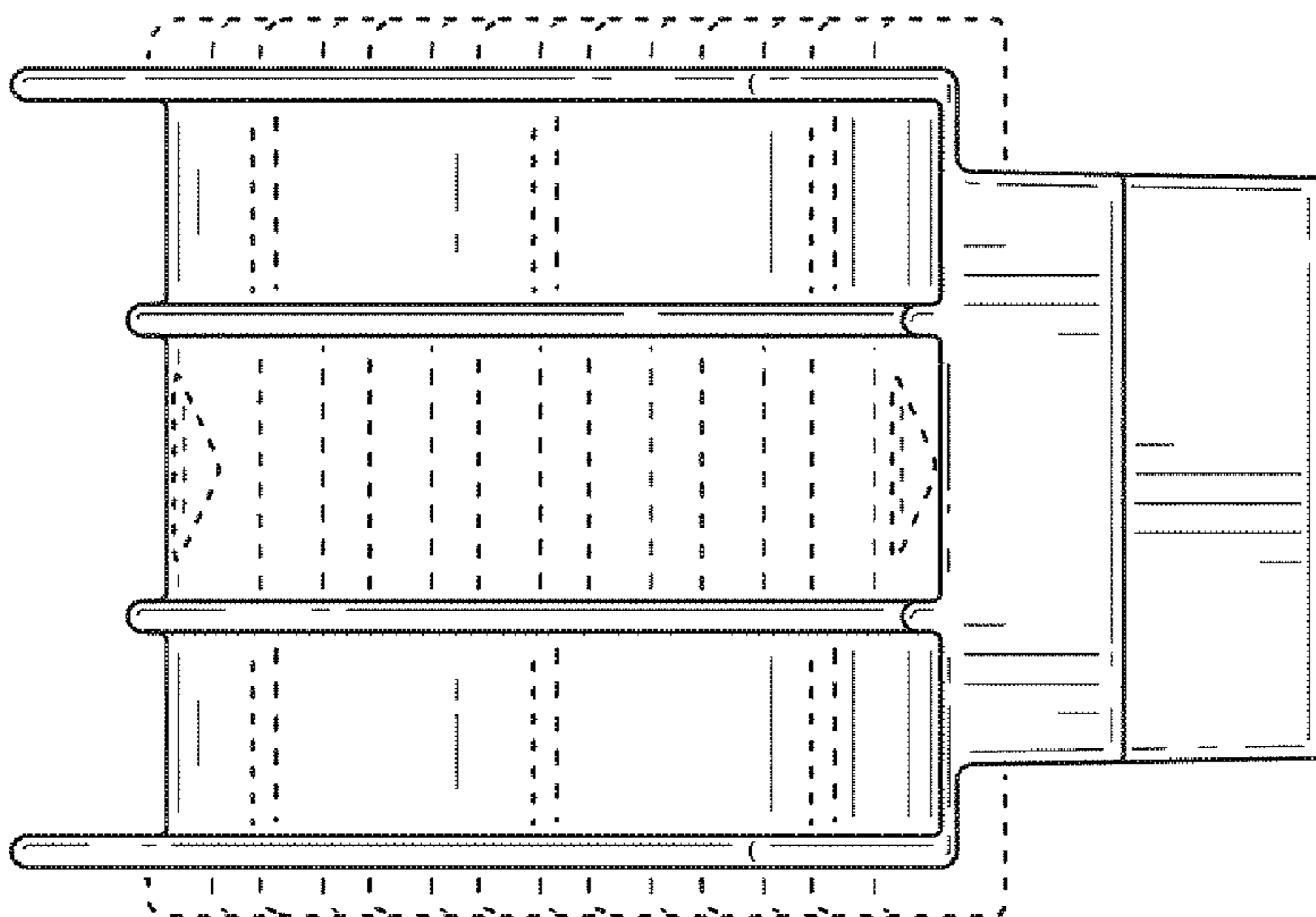

Fig. 3

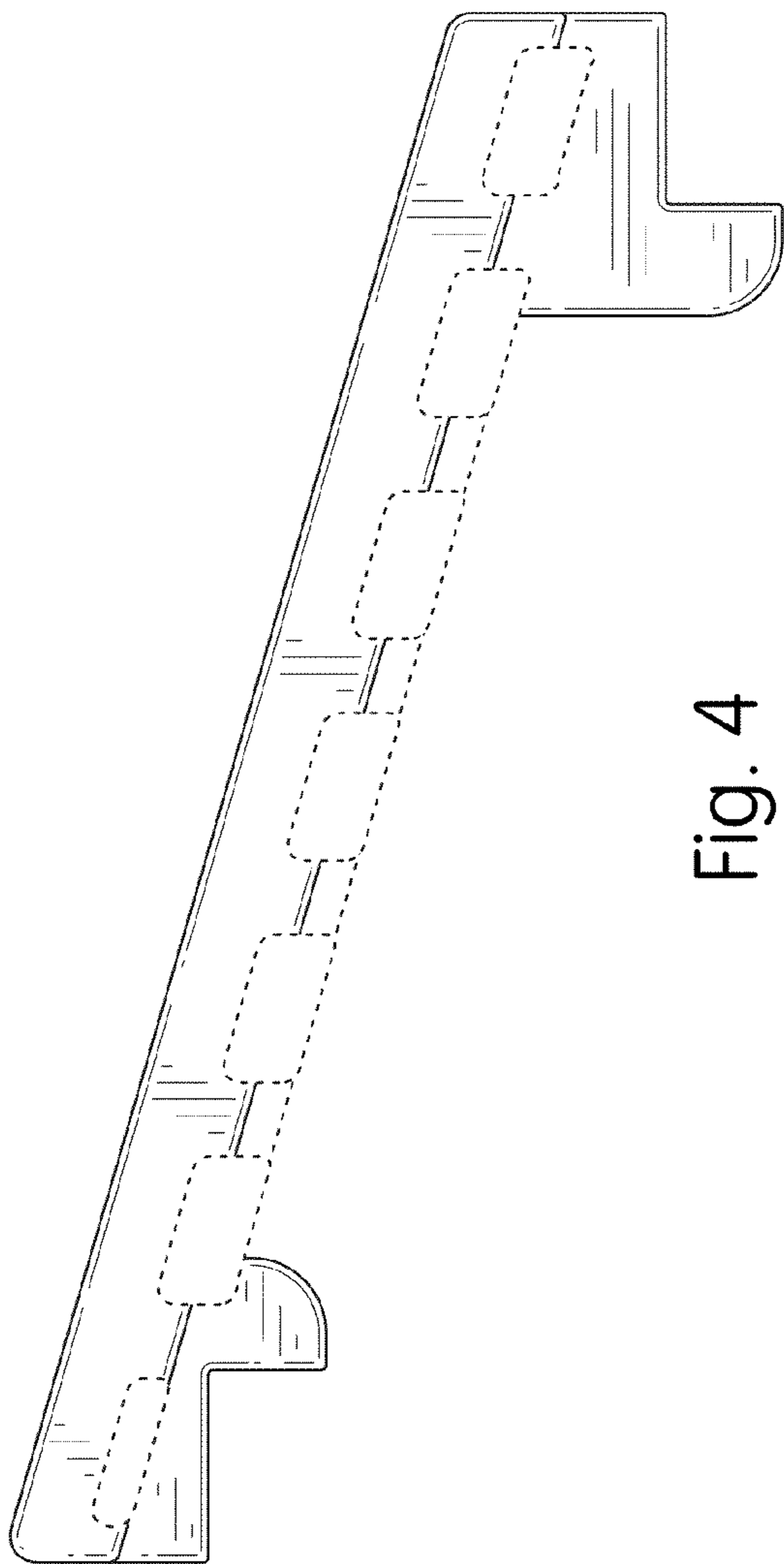

Fig. 4

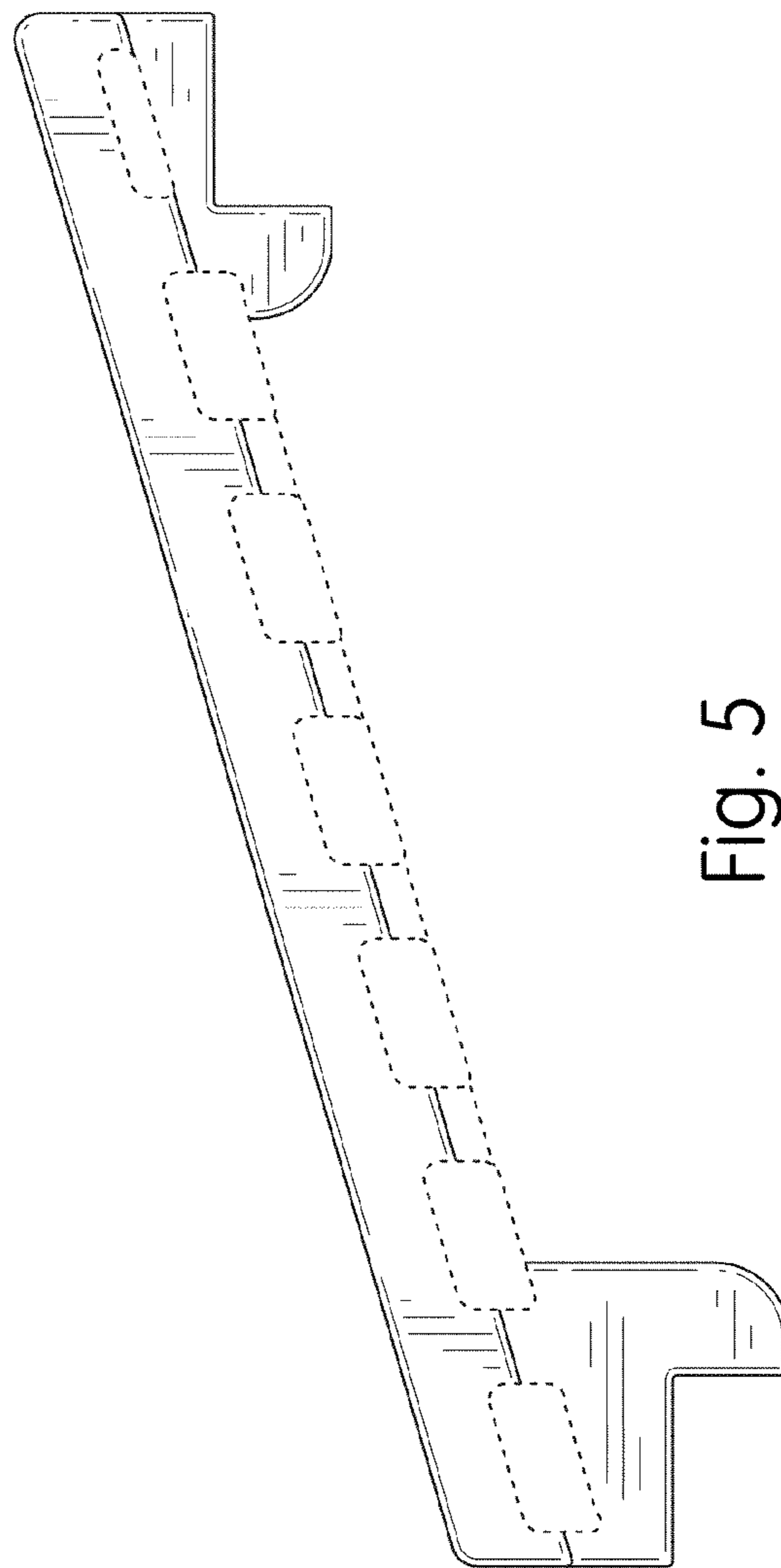

Fig. 5

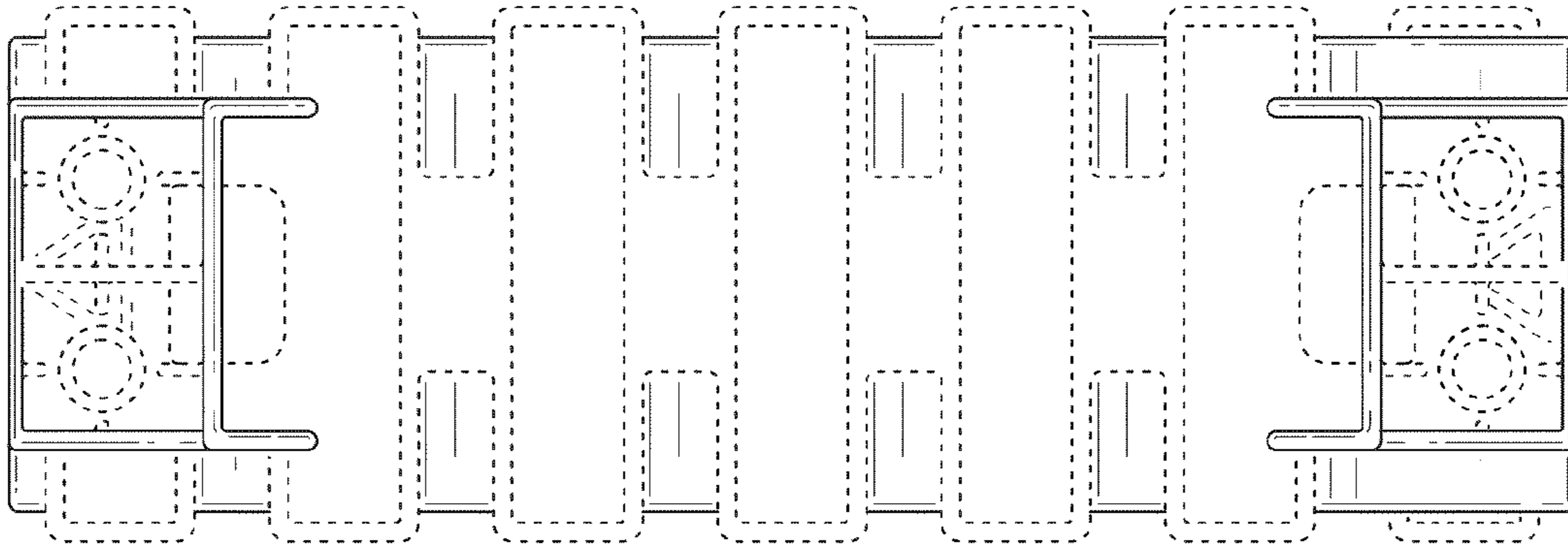

Fig. 7

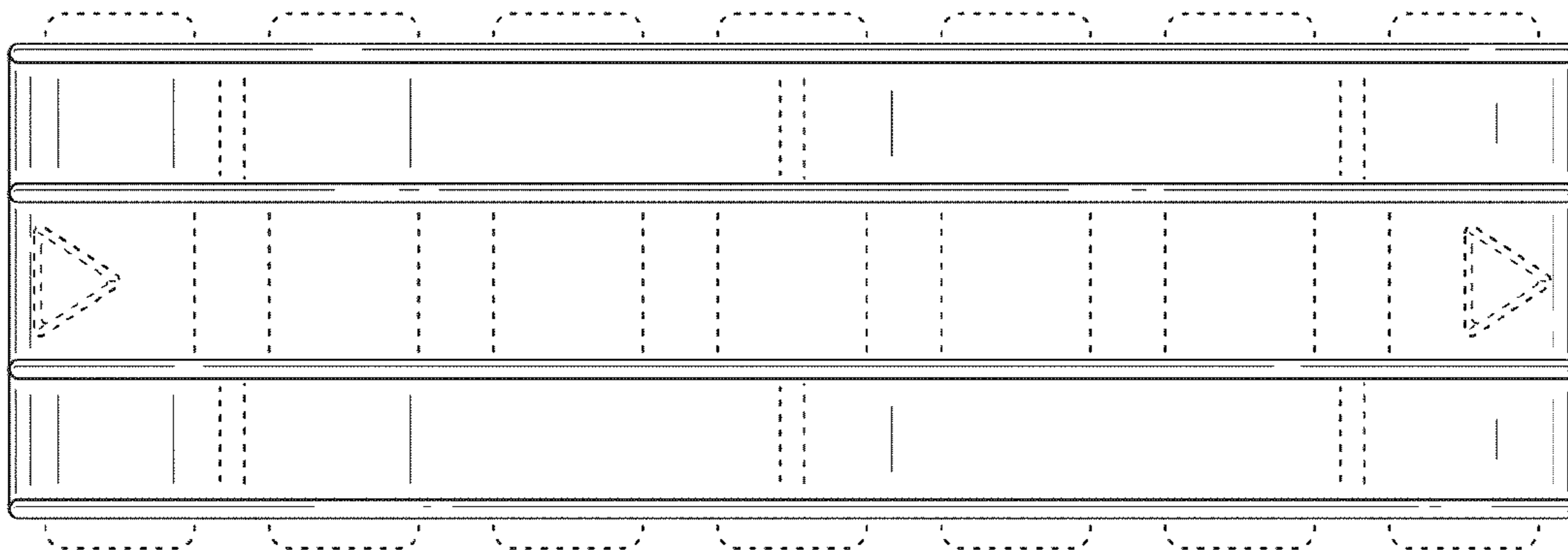

Fig. 6

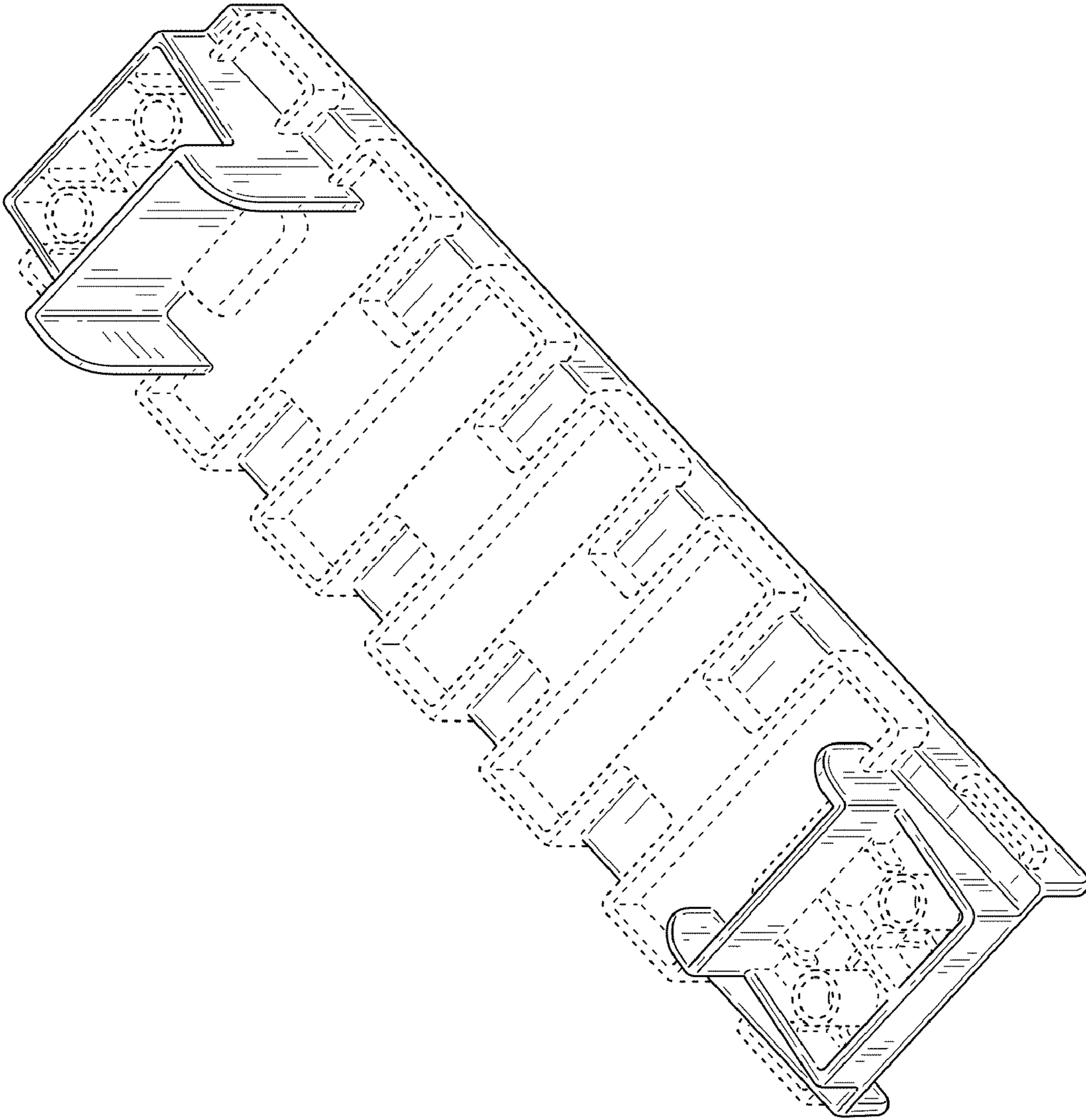

Fig. 8

UNITED STATES PATENT AND TRADEMARK OFFICE
CERTIFICATE OF CORRECTION

PATENT NO. : D640,331 S
APPLICATION NO. : 29/379296
DATED : June 21, 2011
INVENTOR(S) : Thierry Beauregard et al.

Page 1 of 1

It is certified that error appears in the above-identified patent and that said Letters Patent is hereby corrected as shown below:

Title Page,

at the end of the DESCRIPTION,

insert --The shading illustrated in the figures is provided merely to represent the contour of the design and is not intended to be illustrative of the texture, gloss, or surface decoration.--

Signed and Sealed this
Twenty-second Day of November, 2011

A handwritten signature in black ink that reads "David J. Kappos". The signature is written in a cursive, slightly slanted style.

David J. Kappos
Director of the United States Patent and Trademark Office