



US00D640032S

(12) **United States Design Patent**  
**Kretschmer**

(10) **Patent No.:** **US D640,032 S**

(45) **Date of Patent:** **\*\* Jun. 14, 2011**

(54) **COMBINED TILLER HEAD AND JOYSTICK**

(75) **Inventor:** **Steffen Kretschmer**, Cenon sur Vienne (FR)

(73) **Assignee:** **Linde Material Handling GmbH** (DE)

(\*\*) **Term:** **14 Years**

(21) **Appl. No.:** **29/367,360**

(22) **Filed:** **Aug. 6, 2010**

(30) **Foreign Application Priority Data**

Feb. 9, 2010 (EP) ..... 001667361-0005

(51) **LOC (9) Cl.** ..... **12-05**

(52) **U.S. Cl.** ..... **D34/35**

(58) **Field of Classification Search** ..... D34/34,  
D34/35; 280/43.12; 180/89.12, 299, 325;  
187/22, 224

See application file for complete search history.

(56) **References Cited**

**U.S. PATENT DOCUMENTS**

D239,165	S	*	3/1976	Mono	.....	D34/34
D343,935	S	*	2/1994	Drobeck et al.	.....	D34/35
D364,029	S	*	11/1995	Noonan et al.	.....	D34/35
D374,534	S	*	10/1996	Munde et al.	.....	D34/35
D384,478	S	*	9/1997	Prehn et al.	.....	D34/35
D386,876	S	*	11/1997	Niebuhr	.....	D34/34
D401,716	S	*	11/1998	Marcel	.....	D34/34
D416,369	S	*	11/1999	Johansson	.....	D34/28
D419,741	S	*	1/2000	Johansson	.....	D34/28
6,125,971	A	*	10/2000	Niebuhr et al.	.....	187/231
D563,074	S	*	2/2008	Standke	.....	D34/35
D593,274	S	*	5/2009	Knie et al.	.....	D34/35

D600,425	S	*	9/2009	Smiley et al.	.....	D34/35
D601,324	S	*	9/2009	Knie et al.	.....	D34/34
D609,424	S	*	2/2010	Knie et al.	.....	D34/34
2006/0232030	A1	*	10/2006	Passeri	.....	280/43.12

\* cited by examiner

*Primary Examiner* — Cynthia E Ramirez

(74) *Attorney, Agent, or Firm* — The Webb Law Firm

(57) **CLAIM**

The ornamental design for a combined tiller head and joystick, as shown and described.

**DESCRIPTION**

FIG. 1 is a front perspective view of a combined tiller head and joystick showing my new design, as attached to a lift truck;

FIG. 2 is a front perspective view thereof;

FIG. 3 is a rear perspective view thereof;

FIG. 4 is a front perspective view of the joystick portion thereof;

FIG. 5 is a rear perspective view of the joystick portion thereof;

FIG. 6 is a front view thereof;

FIG. 7 is a rear view thereof;

FIG. 8 is a top view thereof; and,

FIG. 9 is a right side view thereof, the left side view being a mirror image.

The portions of the lift truck shown in broken lines in FIG. 1 are included for environmental purposes only, and form no part of the claimed design. The internal portions shown in broken lines in FIGS. 4 and 5 form no part of the claimed design.

The joystick is shown separated from the tiller head in FIGS. 4 and 5 for convenience of illustration.

**1 Claim, 9 Drawing Sheets**

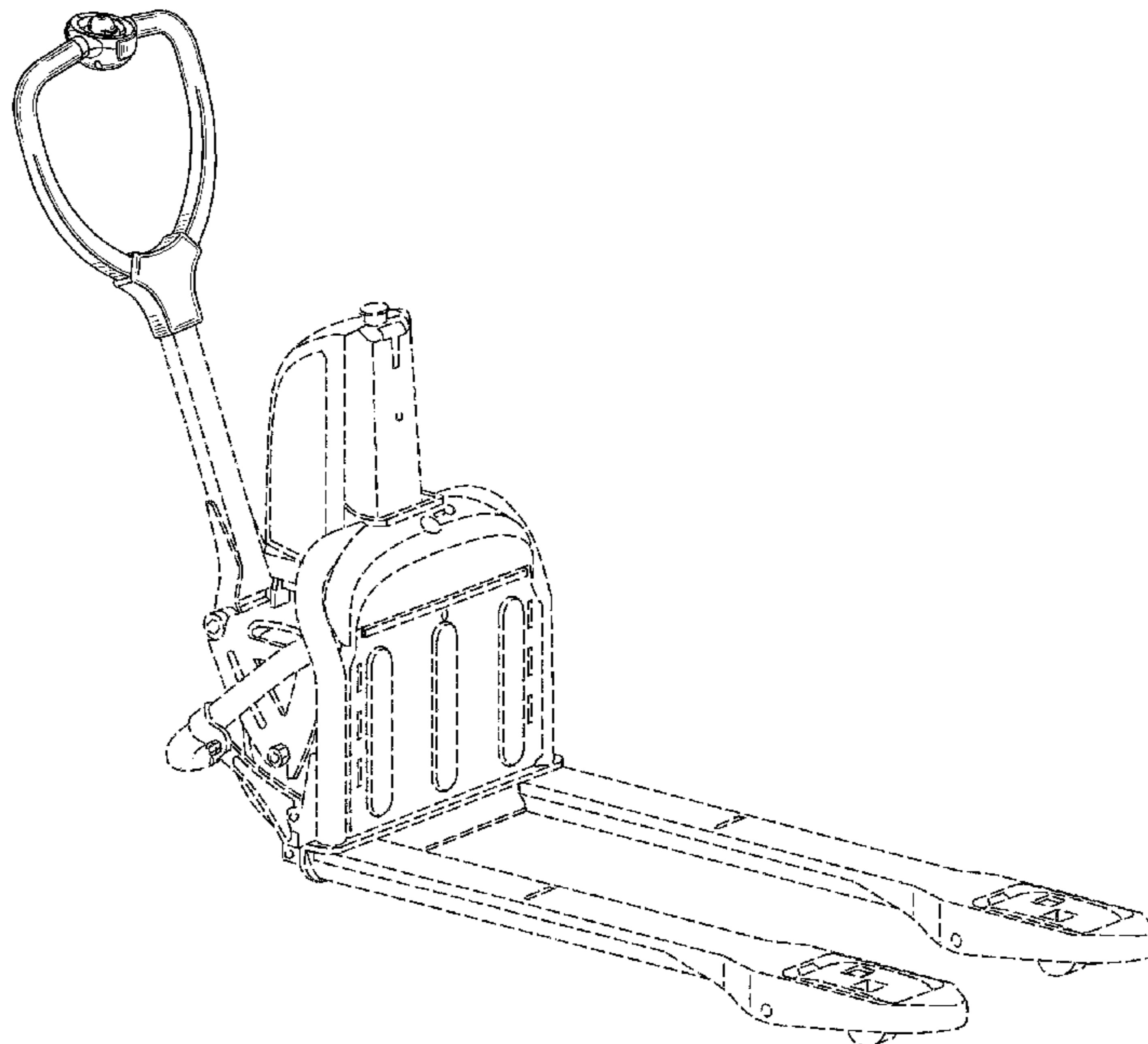

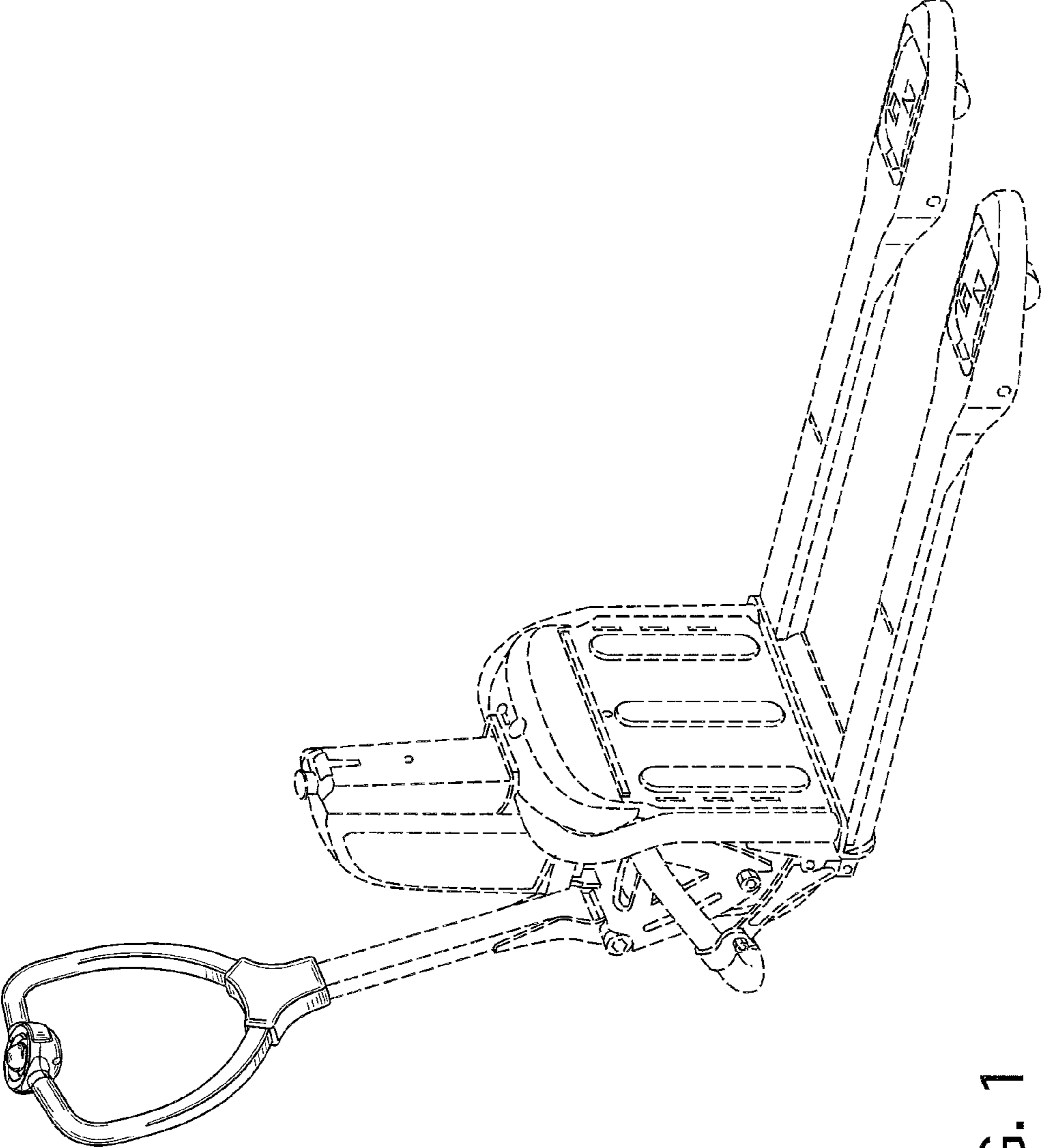

FIG. 1

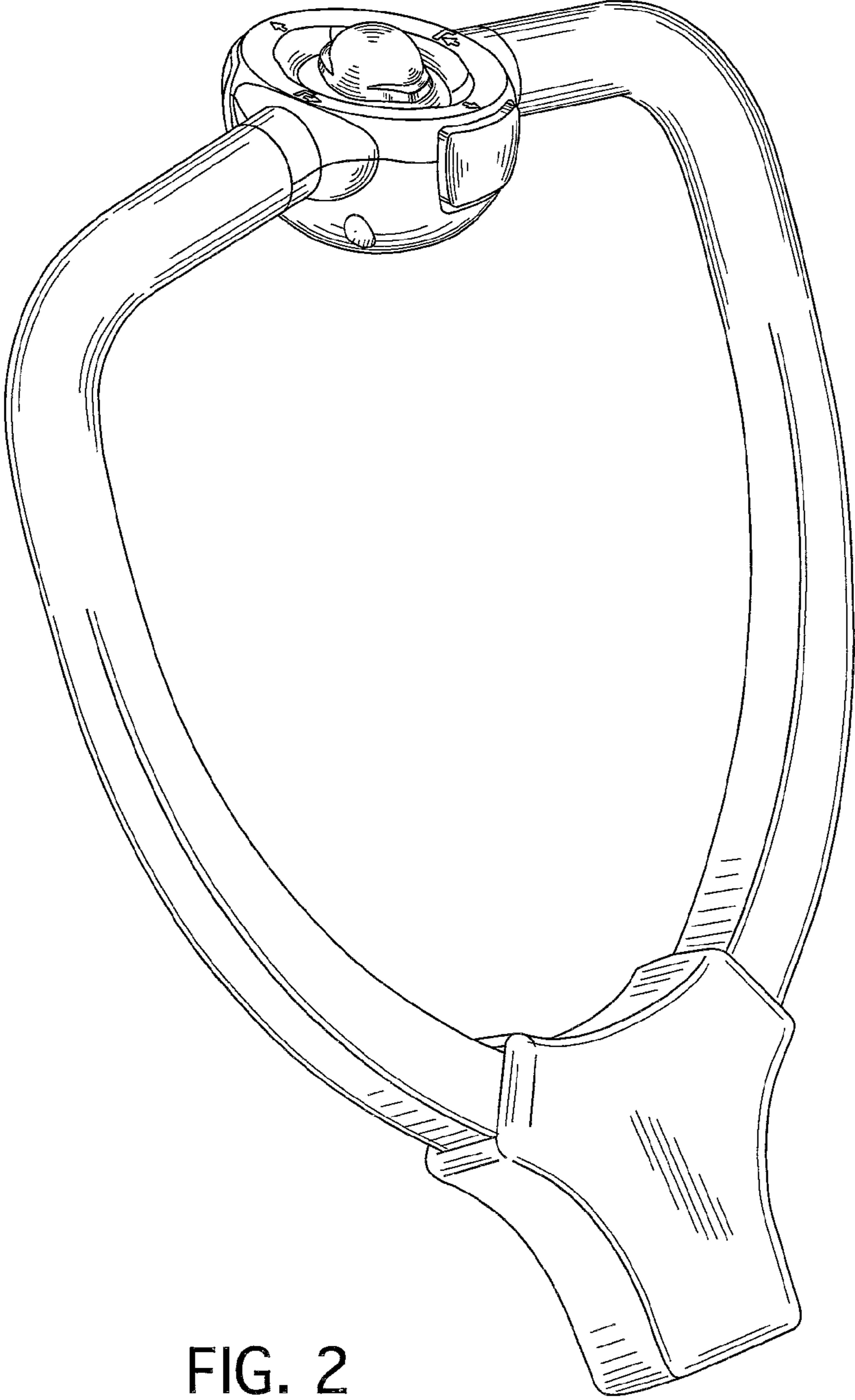

FIG. 2

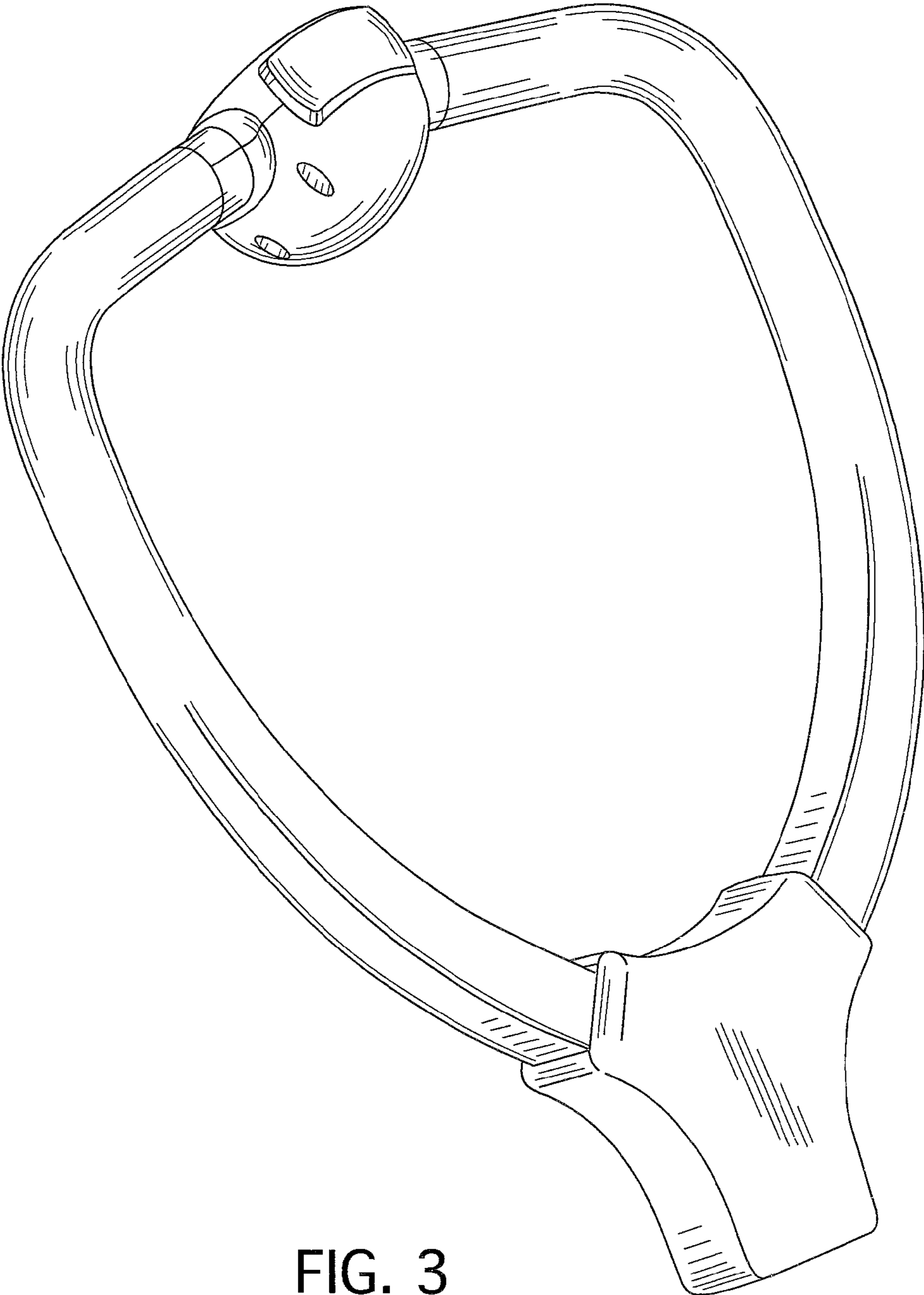

FIG. 3

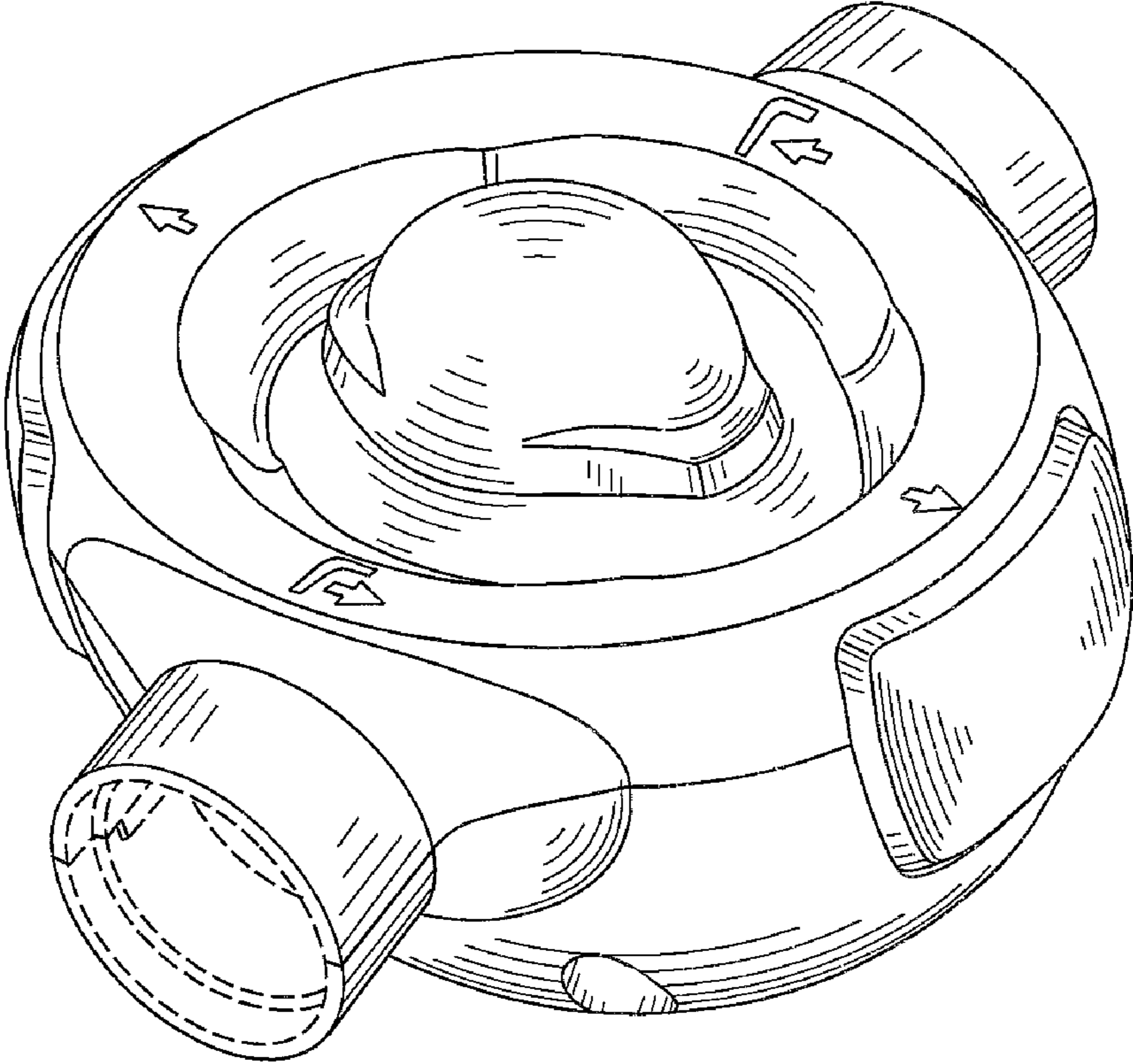

FIG. 4

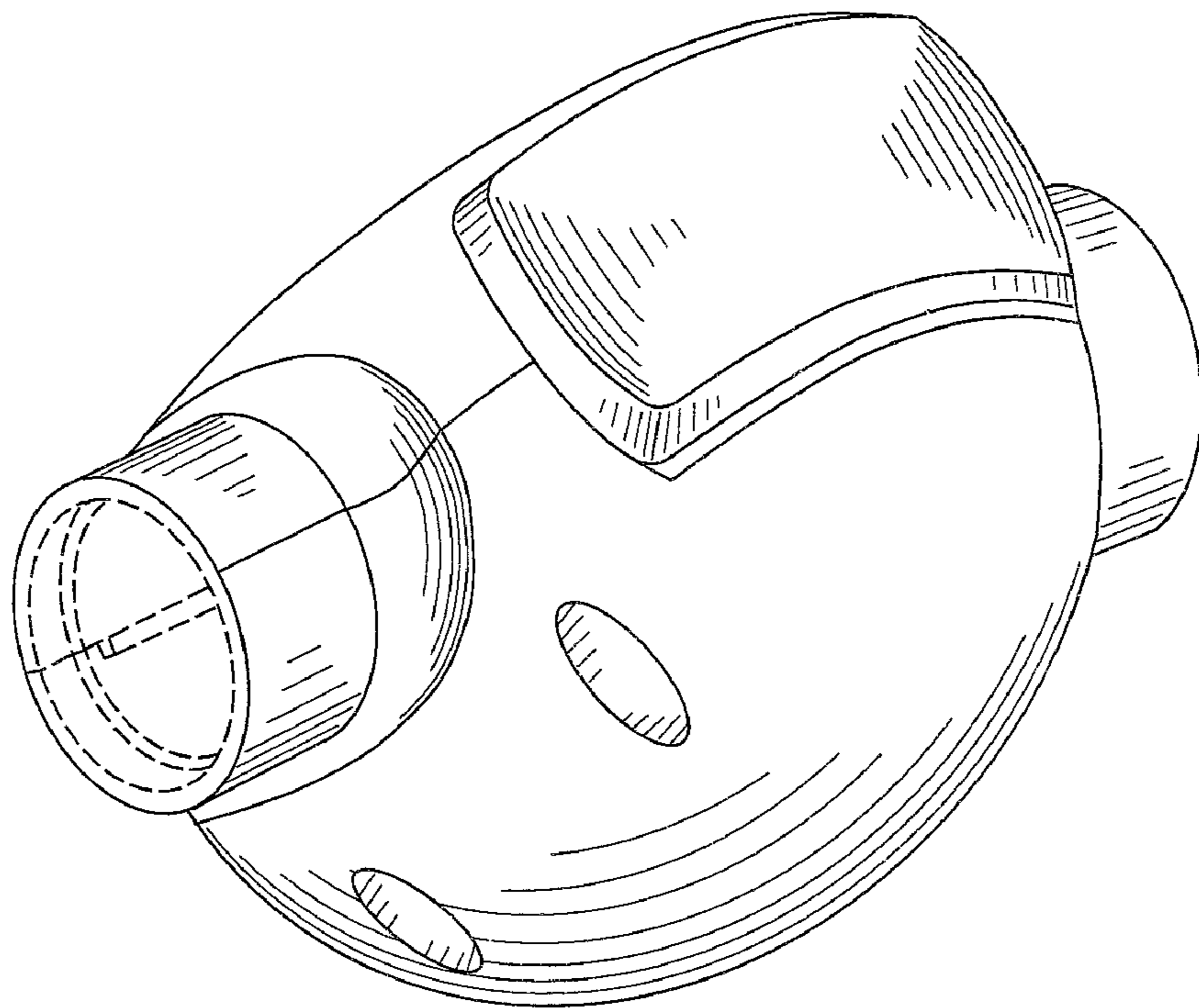

FIG. 5

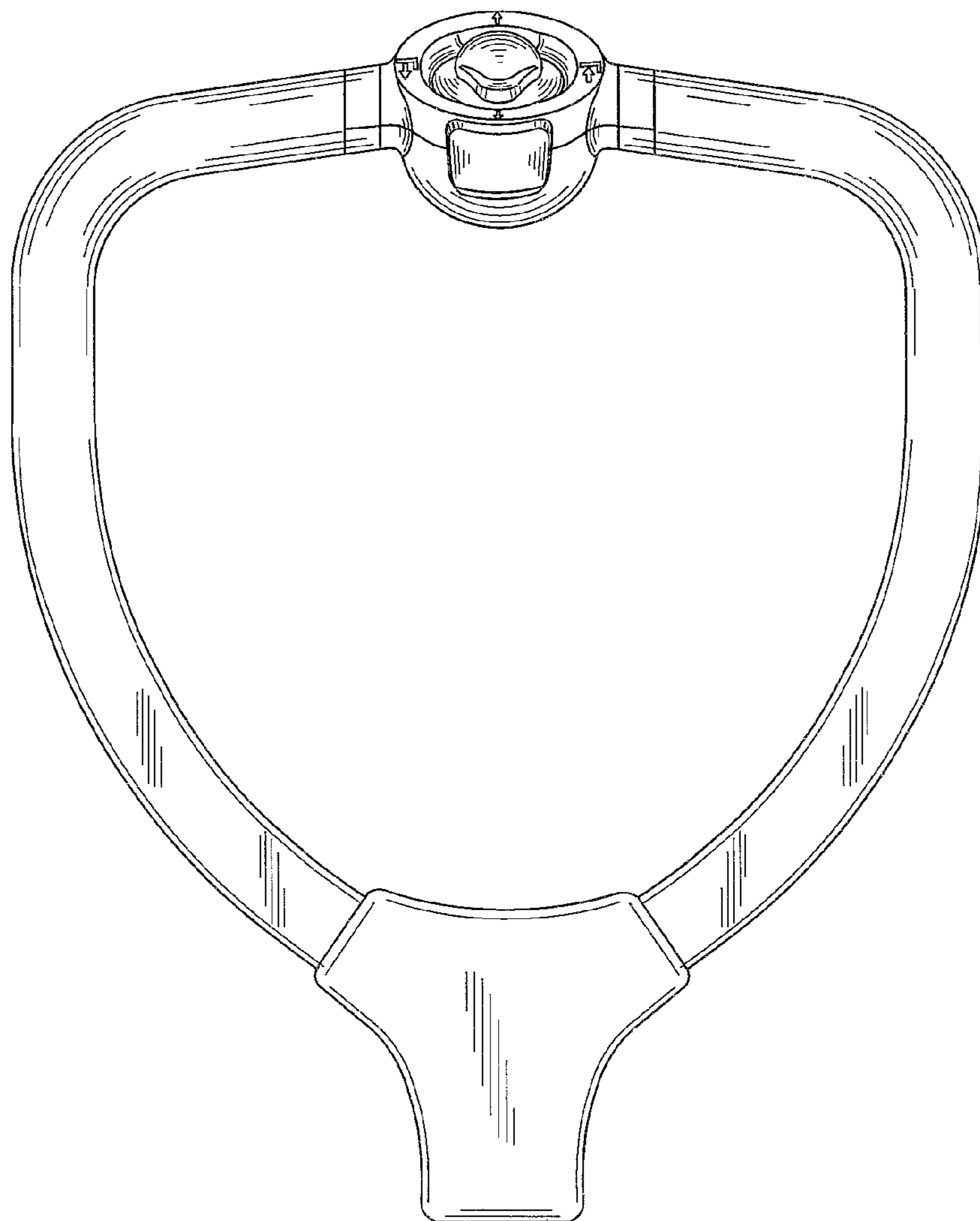

FIG. 6

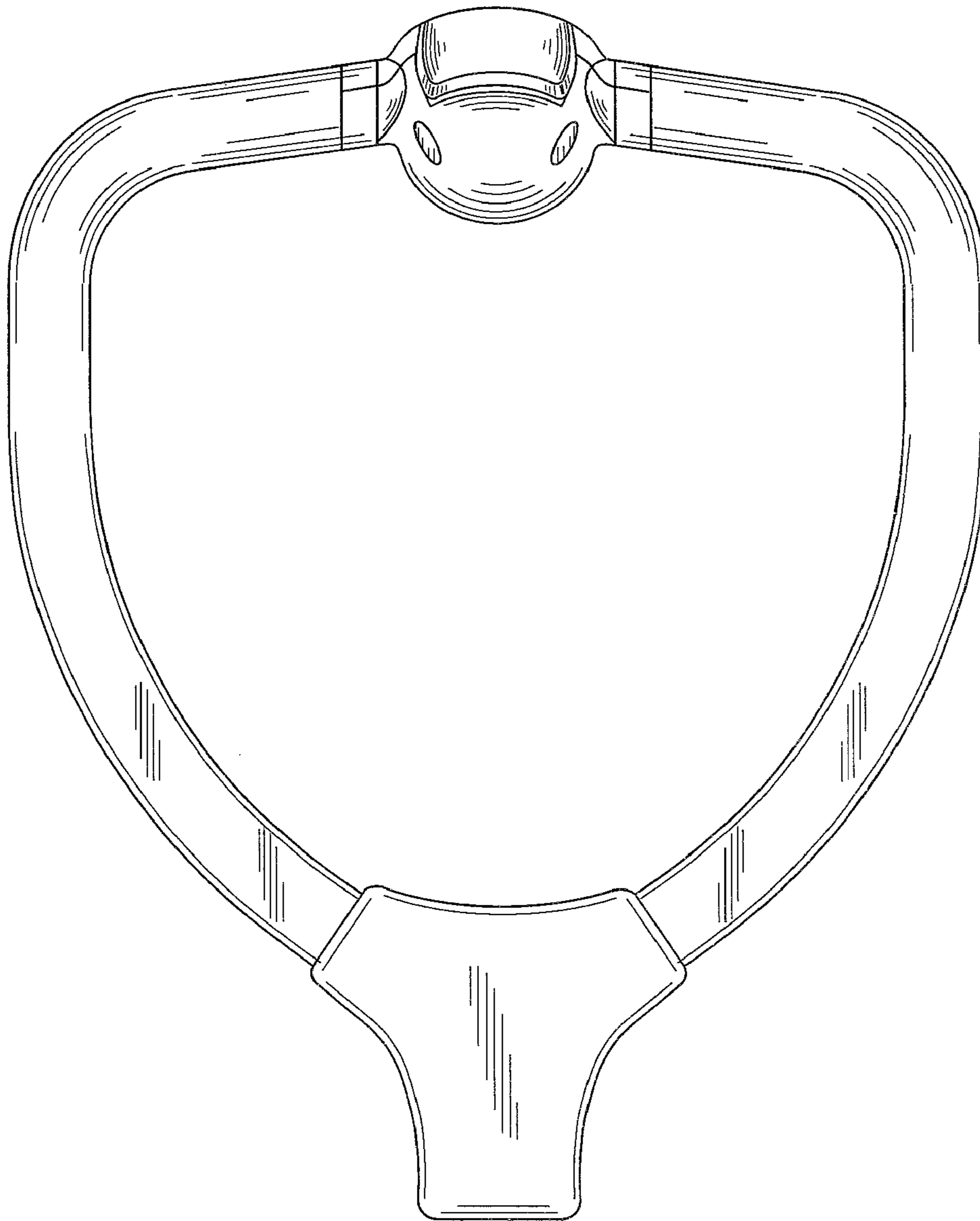

FIG. 7



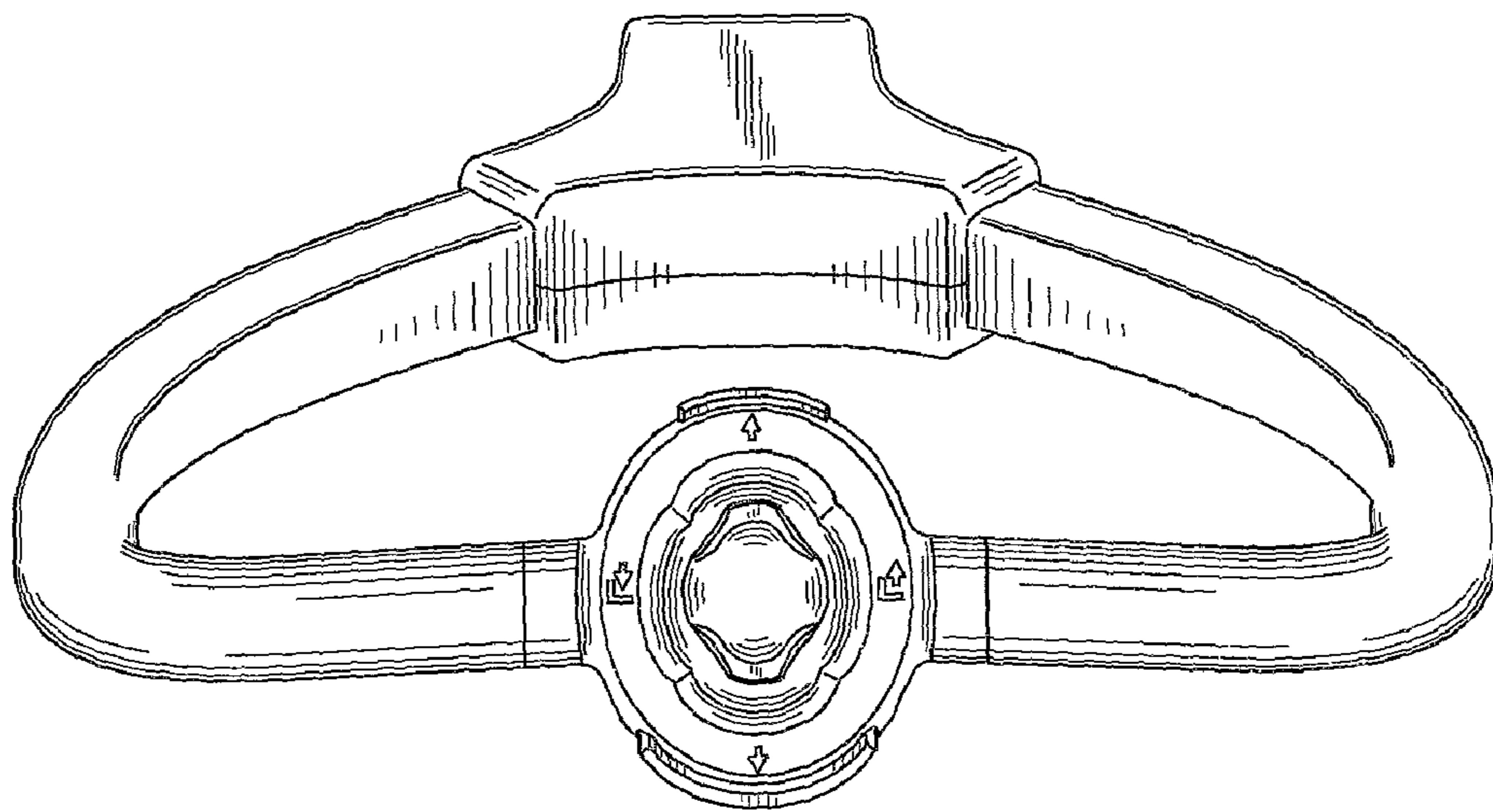

FIG. 8

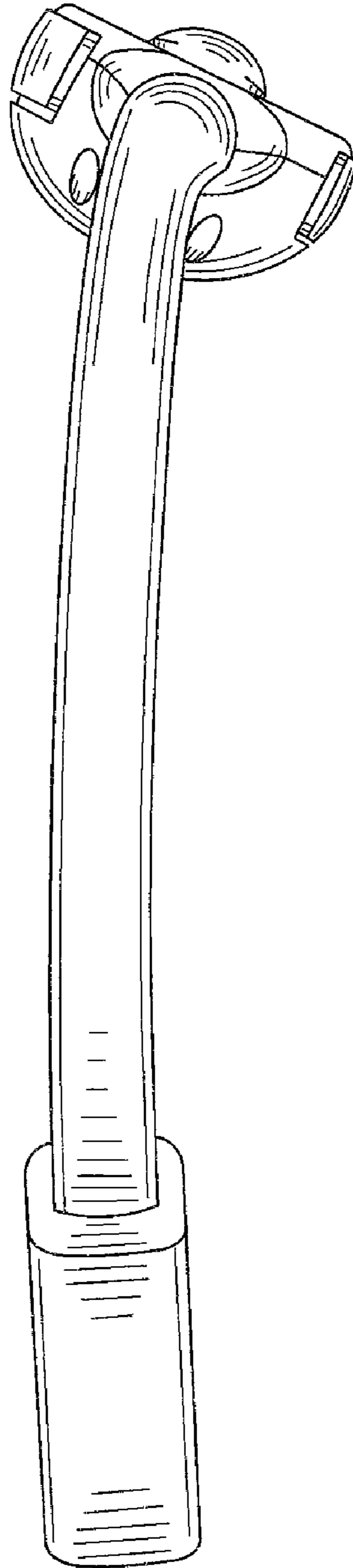

FIG. 9