



US00D639378S

(12) **United States Design Patent**
Burt

(10) **Patent No.:** **US D639,378 S**
(45) **Date of Patent:** **** Jun. 7, 2011**

(54) **CONTROL LEVER**

(75) Inventor: **Eric Christopher Burt**, Broomfield, CO (US)

(73) Assignee: **Magpul Industries Corporation**, Erie, CO (US)

(**) Term: **14 Years**

(21) Appl. No.: **29/368,733**

(22) Filed: **Aug. 27, 2010**

(51) **LOC (9) Cl.** **22-01**

(52) **U.S. Cl.** **D22/108**

(58) **Field of Classification Search** D22/100,
D22/101, 103, 104, 108, 199; D21/572,
D21/573; 42/51, 71.01, 75.01, 75.02, 90,
42/94, 134, 136, 139, 125, 72, 111; 124/67,
124/66, 72, 74; 362/110; 89/132, 138, 144,
89/149

See application file for complete search history.

(56) **References Cited**

U.S. PATENT DOCUMENTS

4,433,610	A *	2/1984	Tatro	89/148
7,654,187	B2 *	2/2010	Hochstrate et al.	89/142
7,806,039	B1 *	10/2010	Gomez	89/132
2008/0302235	A1 *	12/2008	Lauck	89/132
2010/0236394	A1 *	9/2010	Gomez	89/138

OTHER PUBLICATIONS

FTF Industries, AR15 AR-15 Ambidextrous Safety Selector Switch;
Website [Online] Available Web Site: <http://www.ftfindustries.com/>

mm5/merchant.mvc?Screen=PROD&Store_Code=FI&Product_Code=AR-AMBISELECTOR&Category_Code=; Last Update: Unknown; Accessed on: Feb. 4, 2011.
M&A, M16 Safety Selector; Website [Online] Available Web Site: <http://www.mapartsinc.com/productsDetail.asp?id=1171>; Last Update: Unknown; Accessed on: Feb. 4, 2011.

* cited by examiner

Primary Examiner — T. Chase Nelson
Assistant Examiner — Michael Pratt
(74) *Attorney, Agent, or Firm* — Swanson & Bratschun, L.L.C.

(57) **CLAIM**

The ornamental design for a control lever, as shown and described.

DESCRIPTION

FIG. 1 is a top left perspective view of a control lever showing my new design;
FIG. 2 is a front elevation view of the control lever of FIG. 1; and
FIG. 3 is a rear elevation view of the control lever of FIG. 1.
FIG. 4 is a top plan view of the control lever of FIG. 1.
FIG. 5 is a bottom plan view of the control lever of FIG. 1.
FIG. 6 is a left elevation view of the control lever of FIG. 1; and,
FIG. 7 is a right elevation view of the control lever of FIG. 1.
The broken lines showing portions of the design in all figures is included for the purpose of illustrating environment and forms not part of the claimed design.

1 Claim, 2 Drawing Sheets

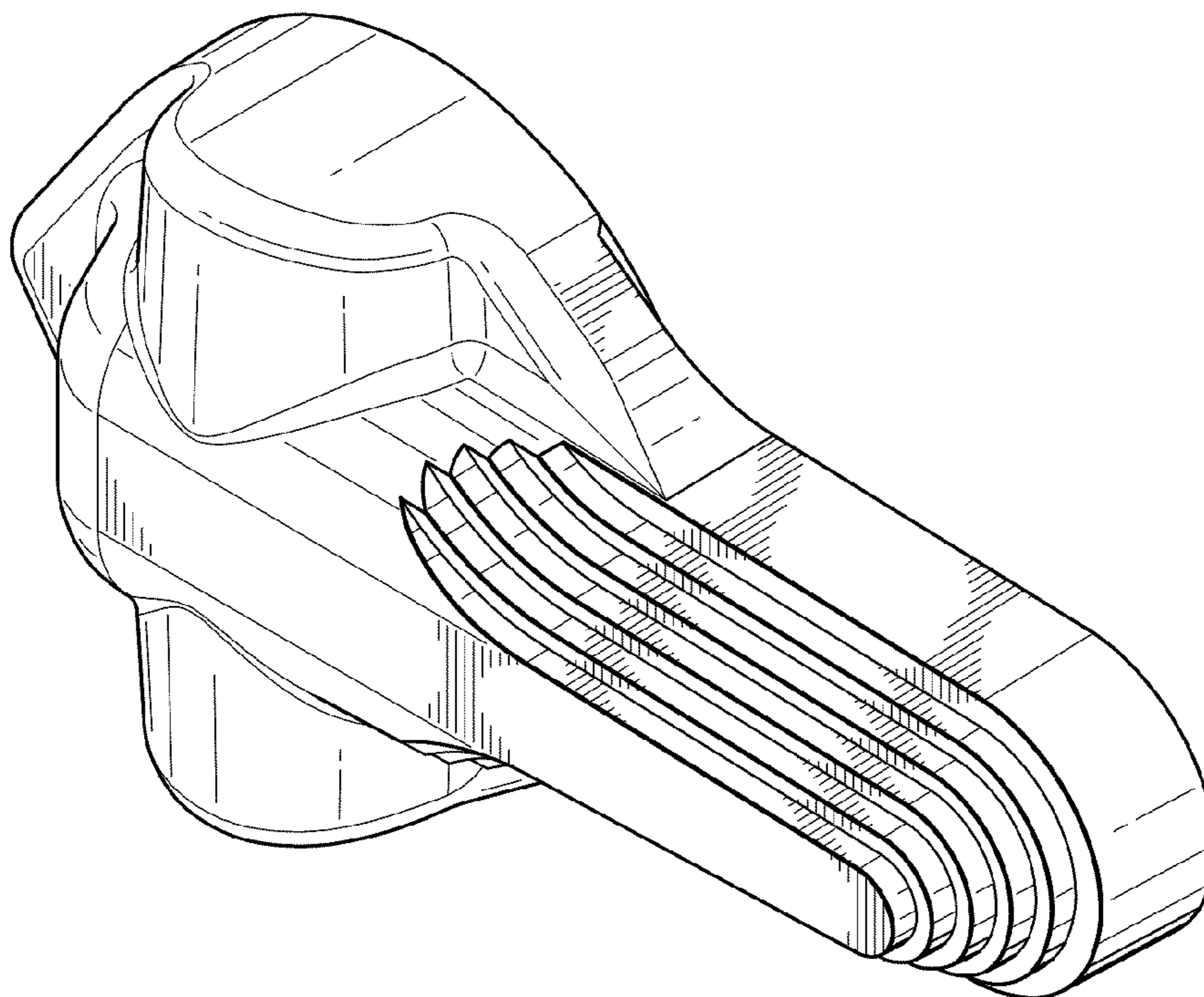

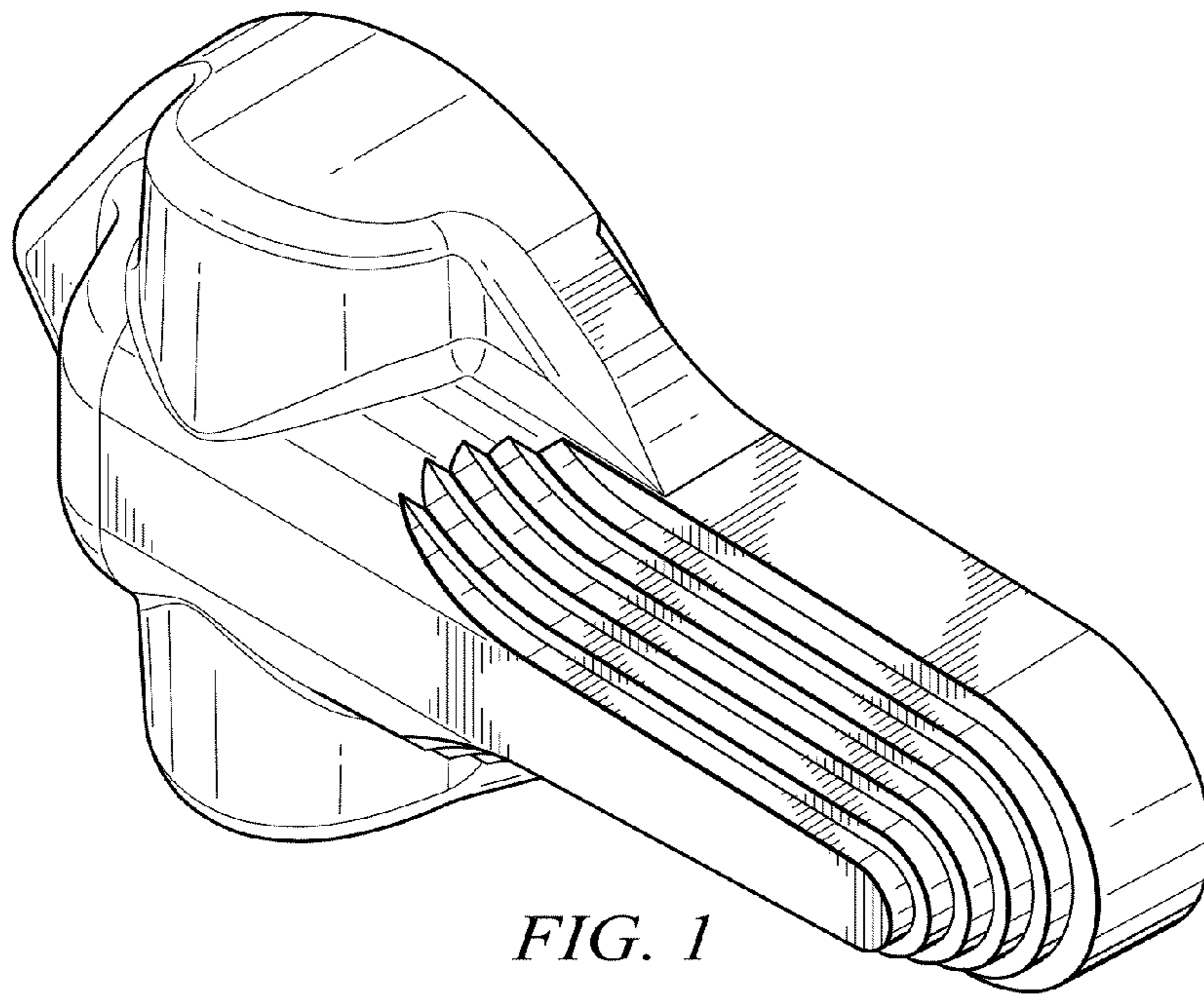

FIG. 1

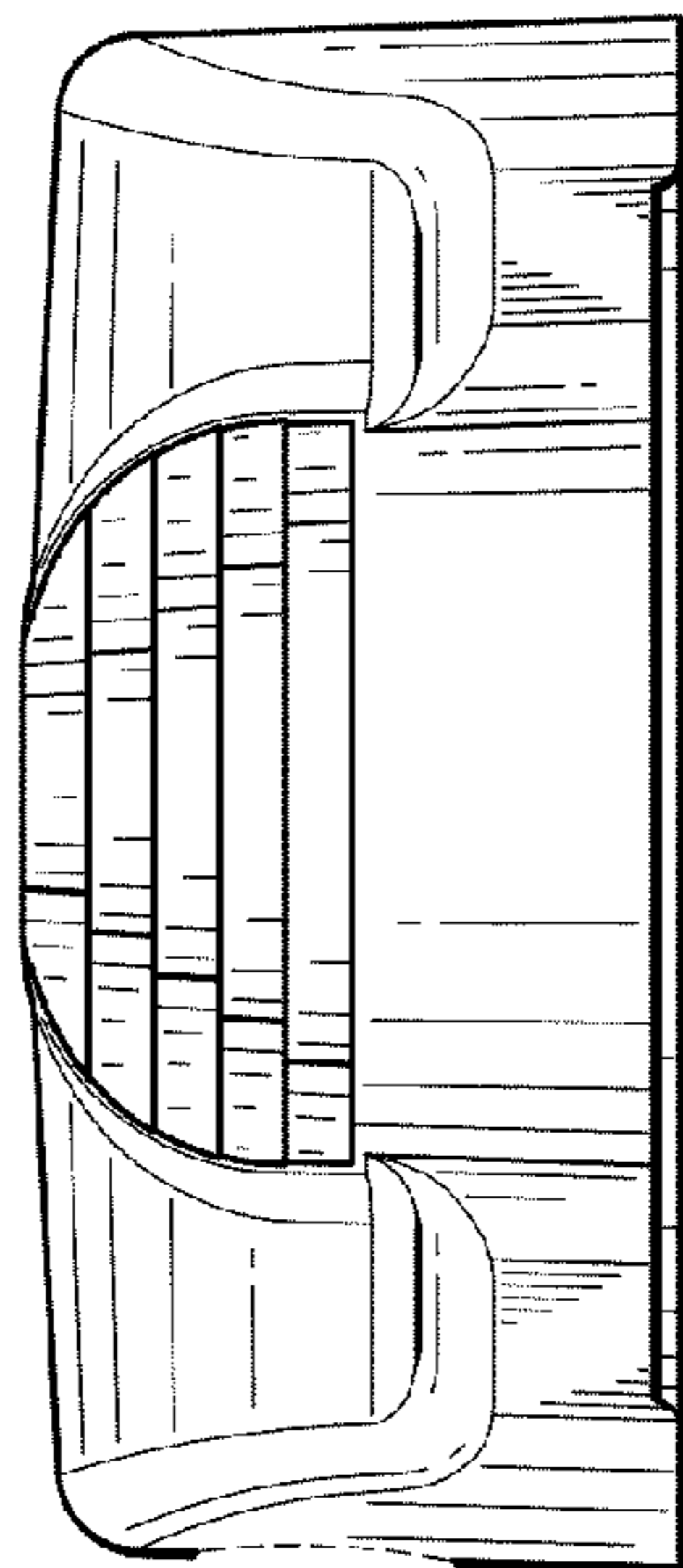

FIG. 2

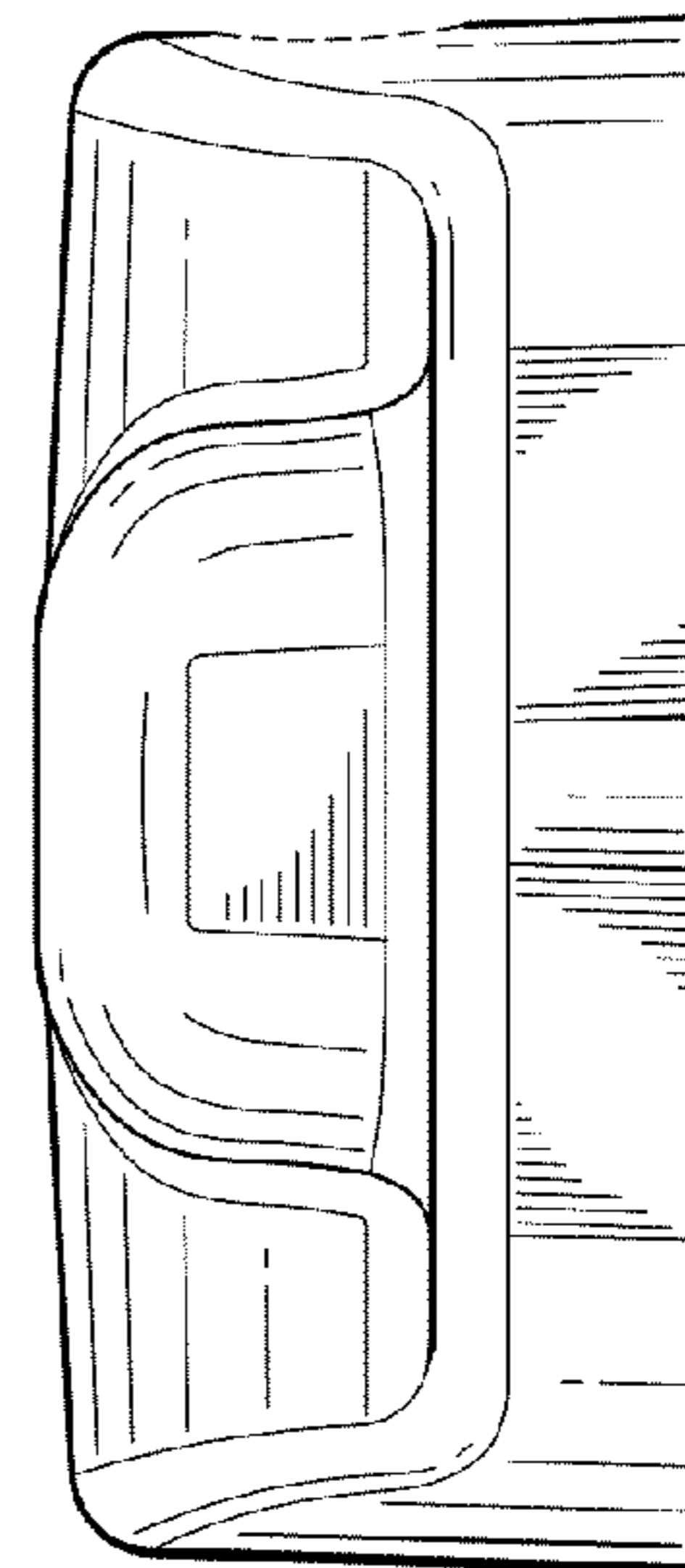

FIG. 3

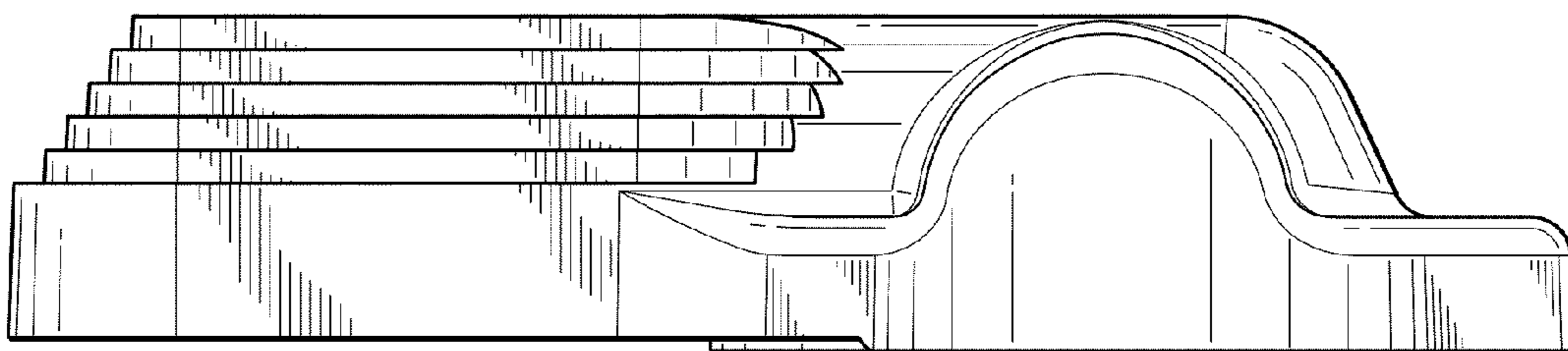

FIG. 4

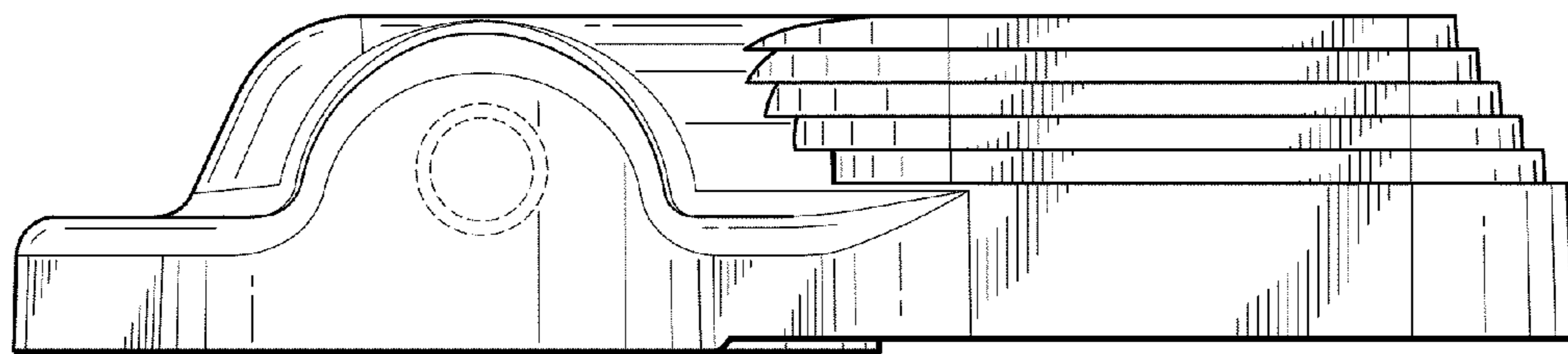

FIG. 5

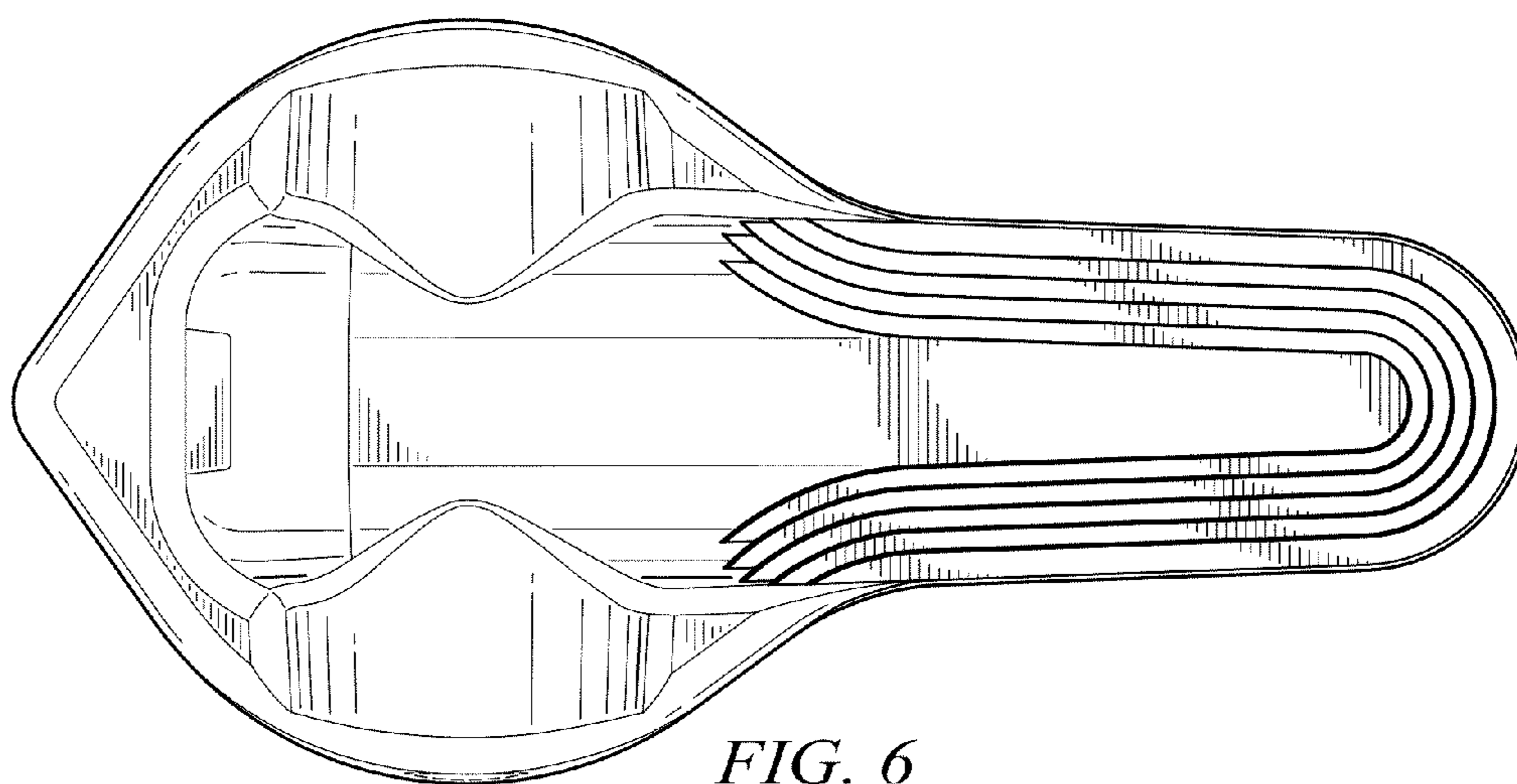

FIG. 6

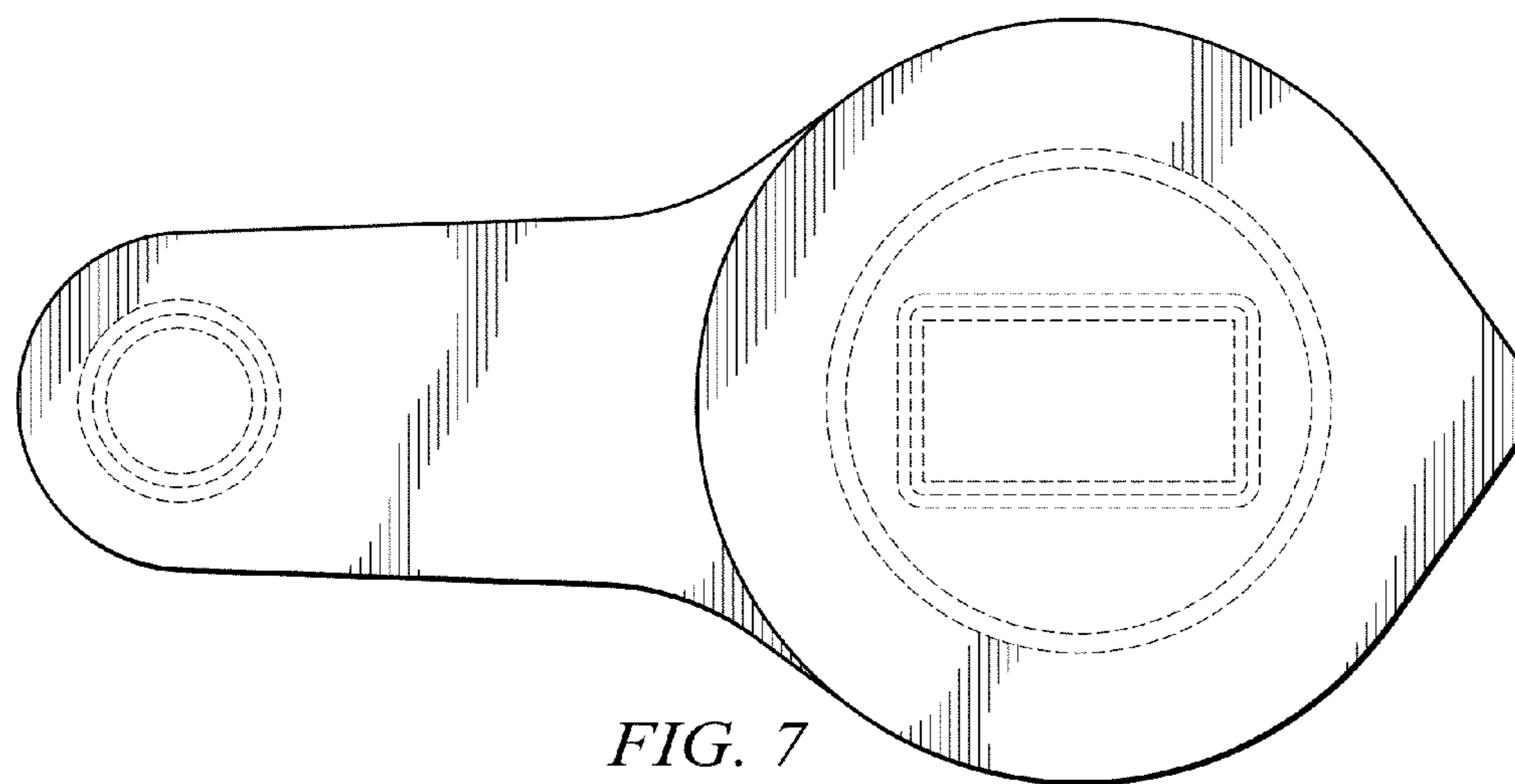

FIG. 7