



US00D639130S

(12) **United States Design Patent**
Ukai et al.

(10) **Patent No.:** **US D639,130 S**
(45) **Date of Patent:** **** Jun. 7, 2011**

(54) **PORTABLE ELECTRIC SAW**
(75) Inventors: **Tomohiro Ukai**, Aichi (JP); **Naohiro Hayakawa**, Aichi (JP); **Fuzhi Zhang**, Jiangsu (CN)

(73) Assignee: **Makita Corporation**, Anjo-shi (JP)

(**) Term: **14 Years**

(21) Appl. No.: **29/382,922**

(22) Filed: **Jan. 10, 2011**

(30) **Foreign Application Priority Data**

Aug. 31, 2010 (JP) 2010-021011

(51) **LOC (9) Cl.** **08-03**

(52) **U.S. Cl.** **D8/64**

(58) **Field of Classification Search** D8/69,
D8/68, 67, 66, 65, 64, 62, 61; 30/92, 394,
30/393, 392, 377, 376, 371; 74/50, 49; 173/217,
173/216; 83/699.21; 446/145

See application file for complete search history.

(56) **References Cited**

U.S. PATENT DOCUMENTS

D341,536 S * 11/1993 Fukuda et al. D8/64
D500,651 S * 1/2005 Andriolo D8/64
D506,117 S * 6/2005 Sun et al. D8/64
D524,130 S * 7/2006 Wolf et al. D8/64
D544,327 S * 6/2007 Sterpka et al. D8/64

D545,657 S * 7/2007 Yamamoto et al. D8/64
D551,046 S * 9/2007 Yamamoto et al. D8/64
D551,930 S * 10/2007 Yamada et al. D8/64
D582,739 S * 12/2008 Aoki et al. D8/64
D591,574 S * 5/2009 DiPasquale et al. D8/64
D596,005 S * 7/2009 Schoch D8/64
D623,496 S * 9/2010 Aoki et al. D8/62
D631,314 S * 1/2011 Baxter D8/64

FOREIGN PATENT DOCUMENTS

JP D1153936 S 9/2002

* cited by examiner

Primary Examiner — Austin Murphy

(74) *Attorney, Agent, or Firm* — Posz Law Group, PLC

(57) **CLAIM**

The ornamental design for a portable electric saw, as shown and described.

DESCRIPTION

FIG. 1 is a perspective view of top, front, and left side of a portable electric saw showing our new design;
FIG. 2 is a front view thereof;
FIG. 3 is a rear view thereof;
FIG. 4 is a top view thereof;
FIG. 5 is a bottom view thereof;
FIG. 6 is a left view thereof; and,
FIG. 7 is a right view thereof.

The broken lines and the areas within the broken lines are included for illustrative purposes only and form no part of the claimed design.

1 Claim, 5 Drawing Sheets

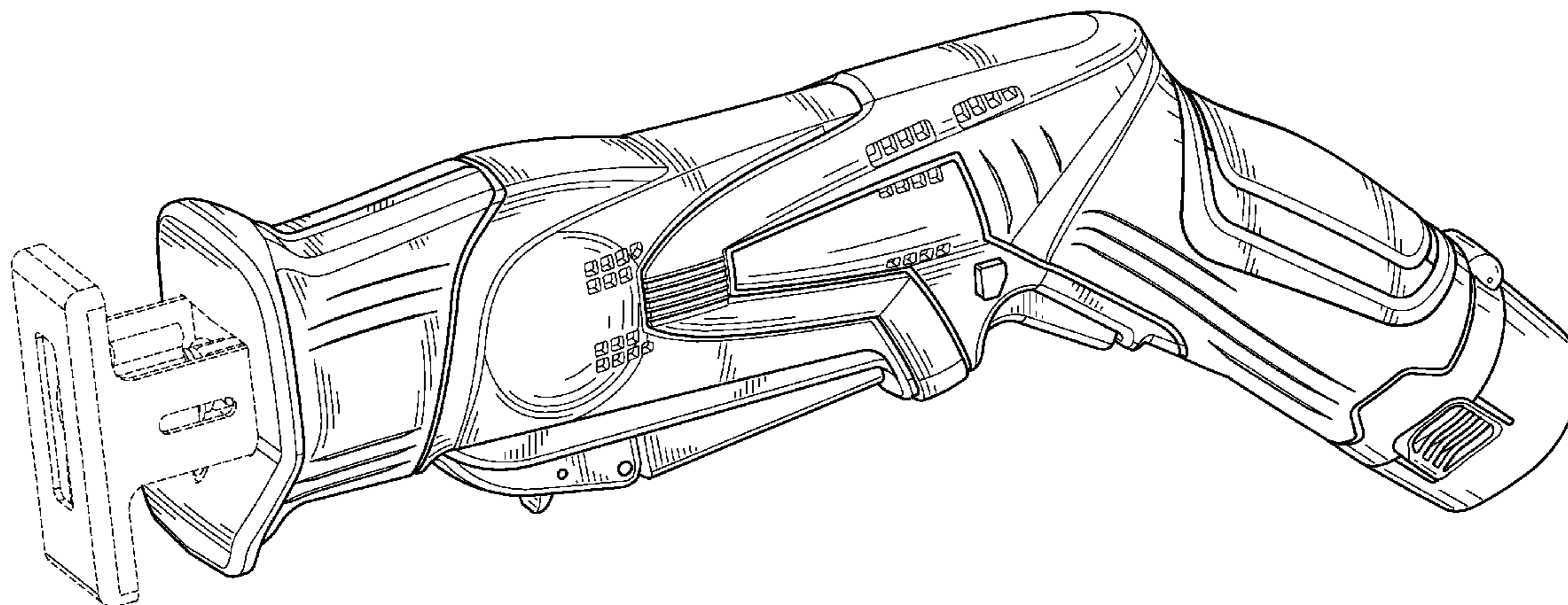

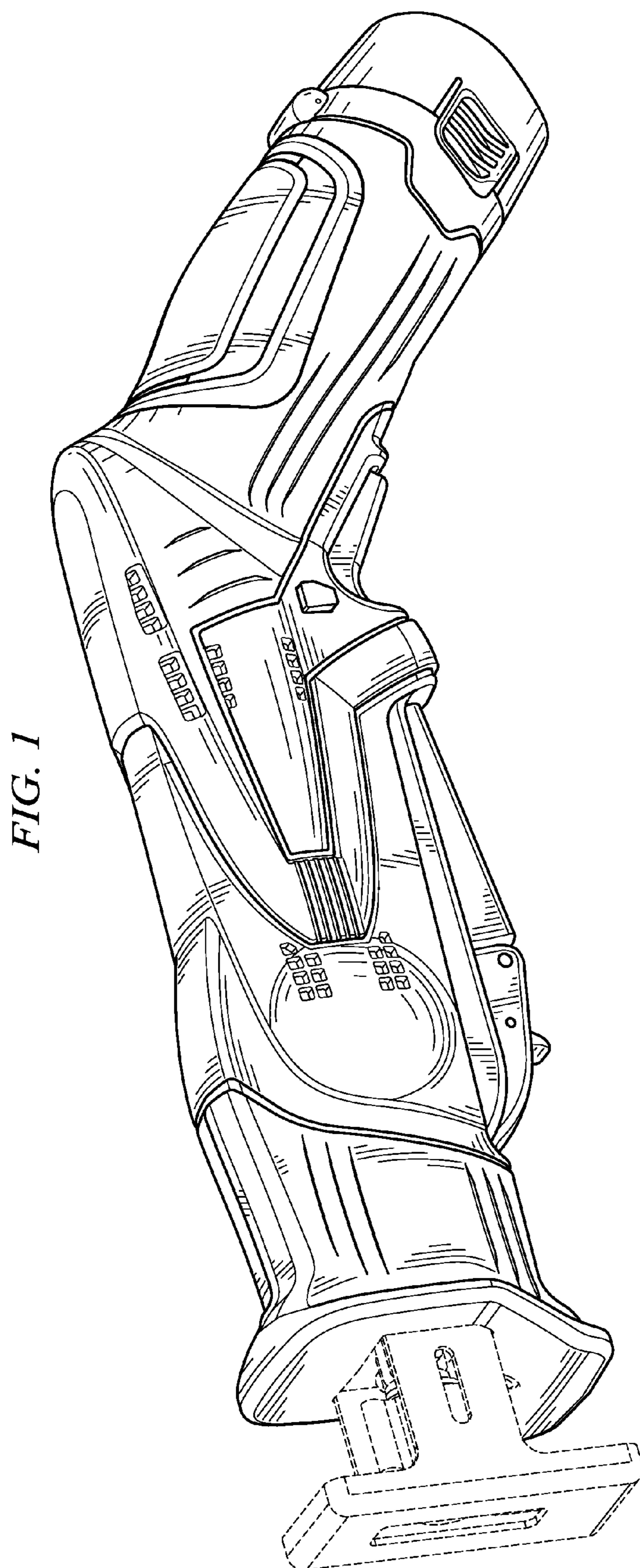

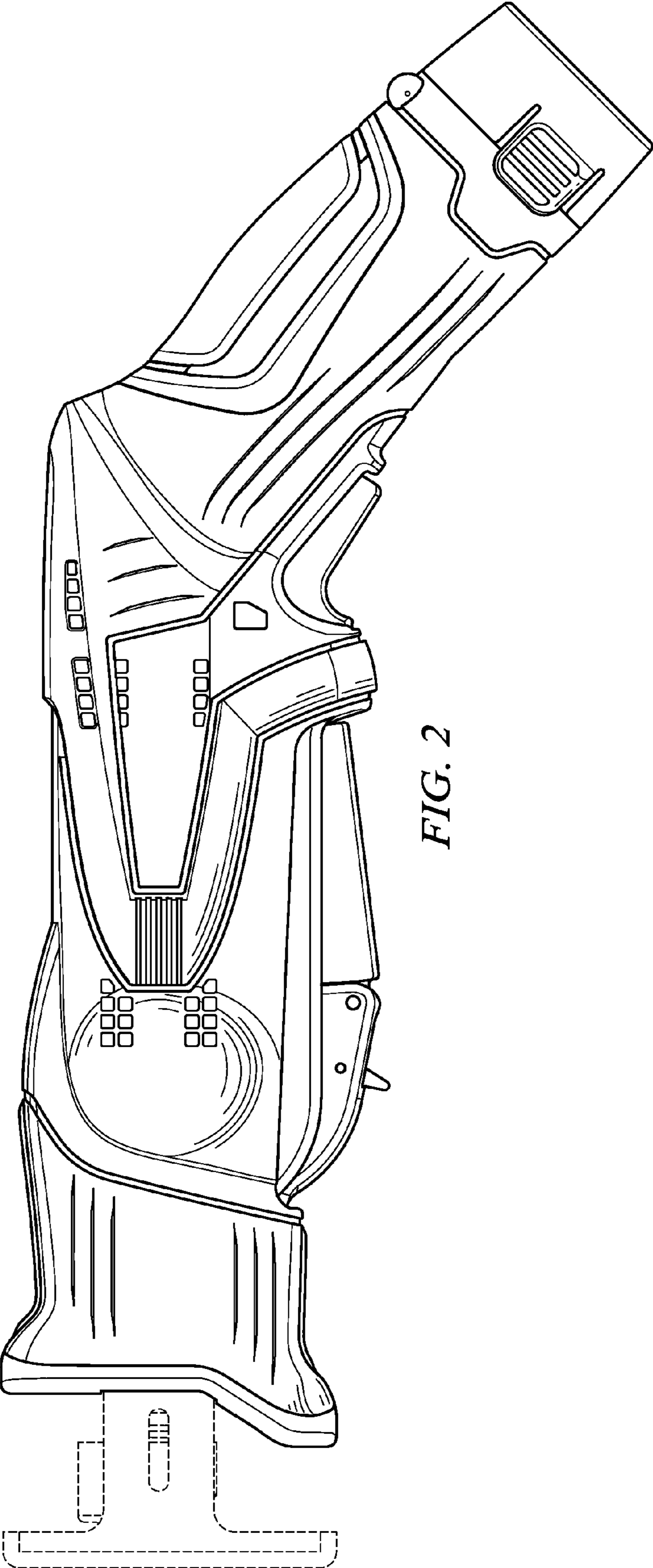

FIG. 2

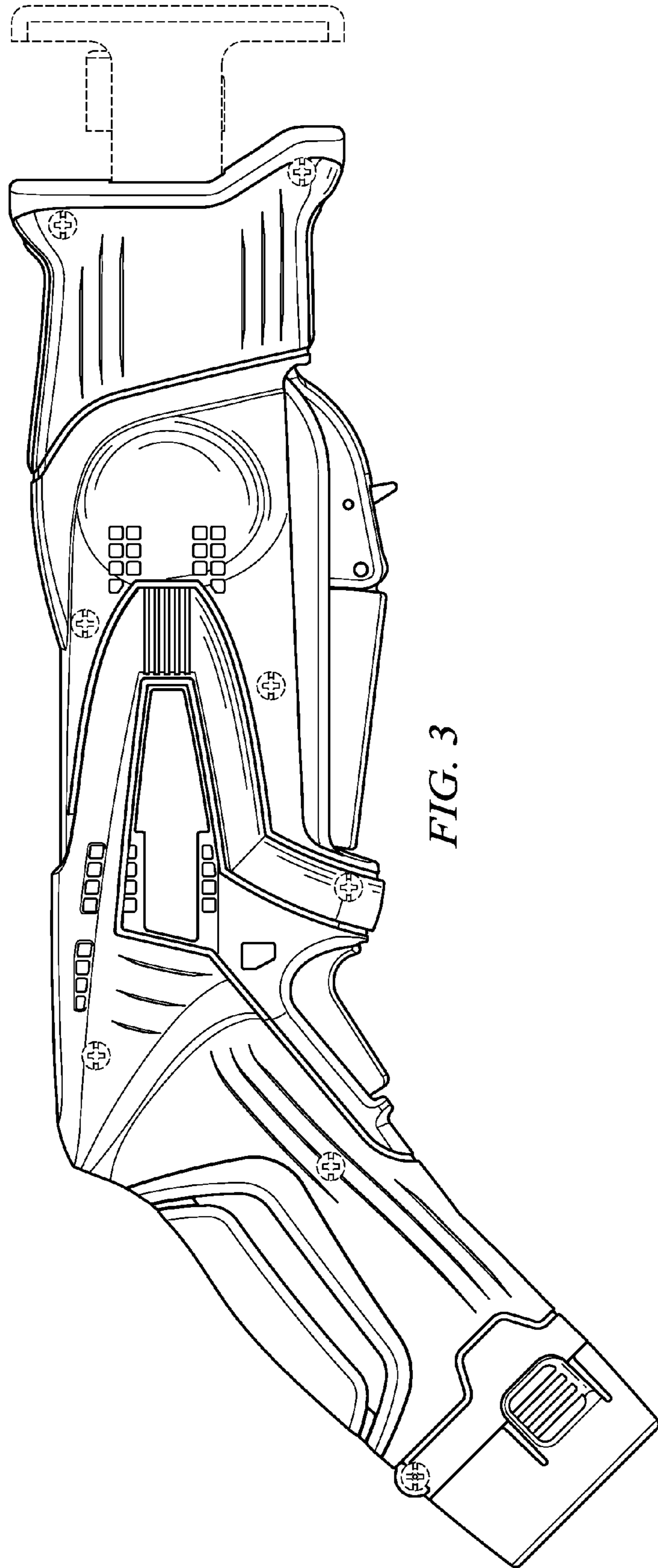

FIG. 3

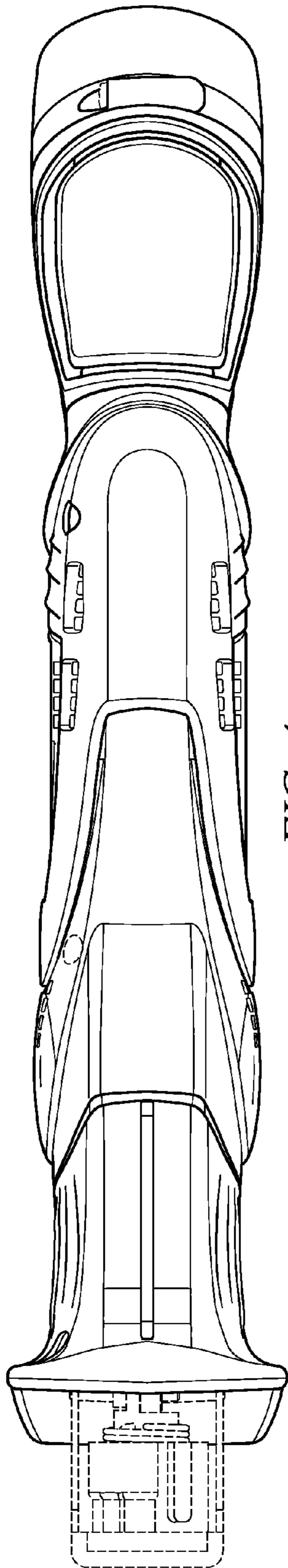

FIG. 4

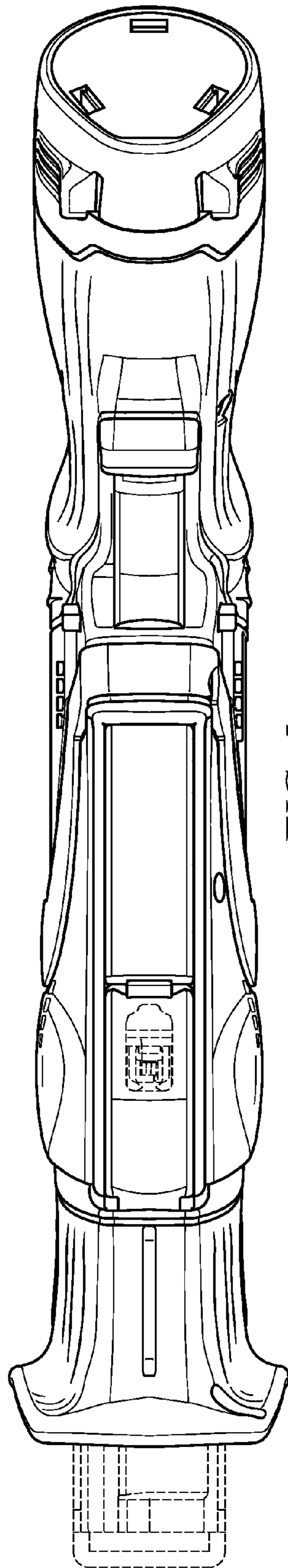

FIG. 5

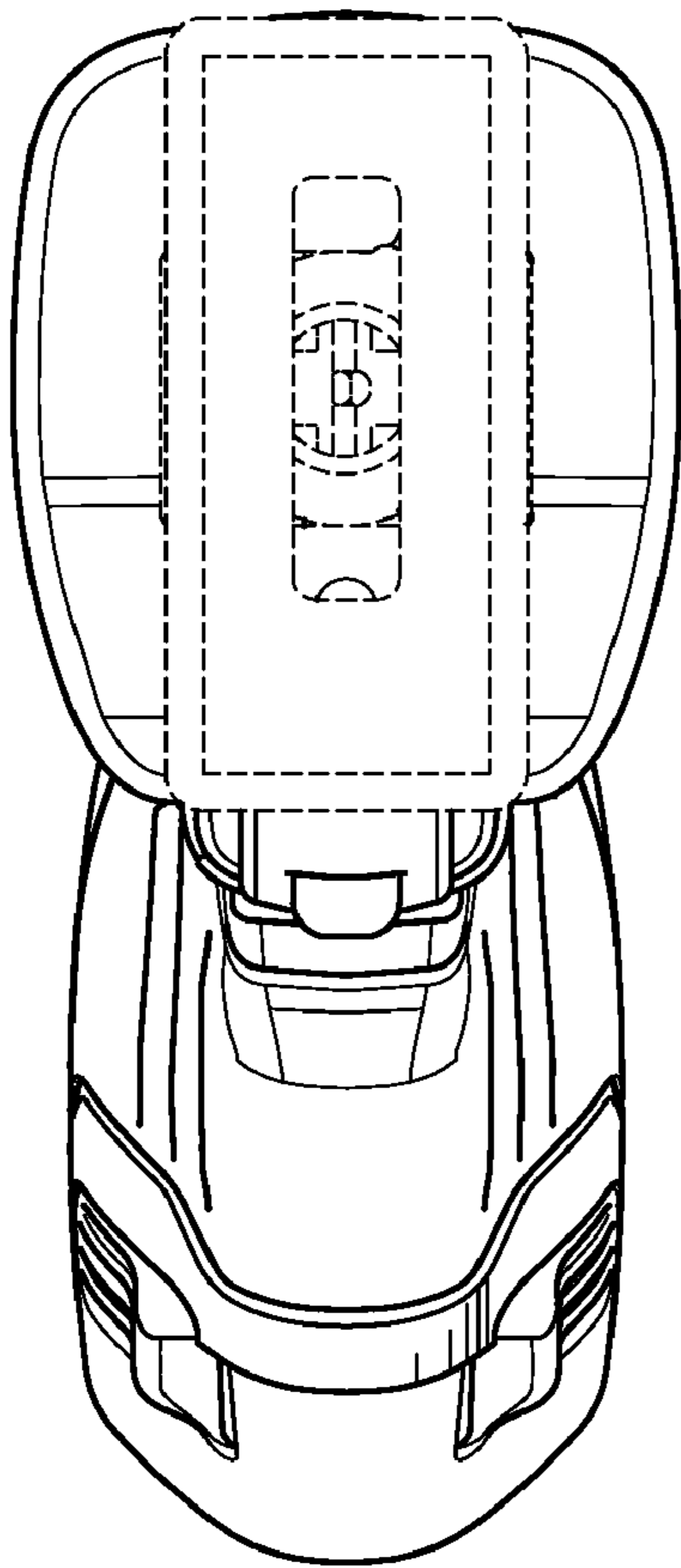

FIG. 6

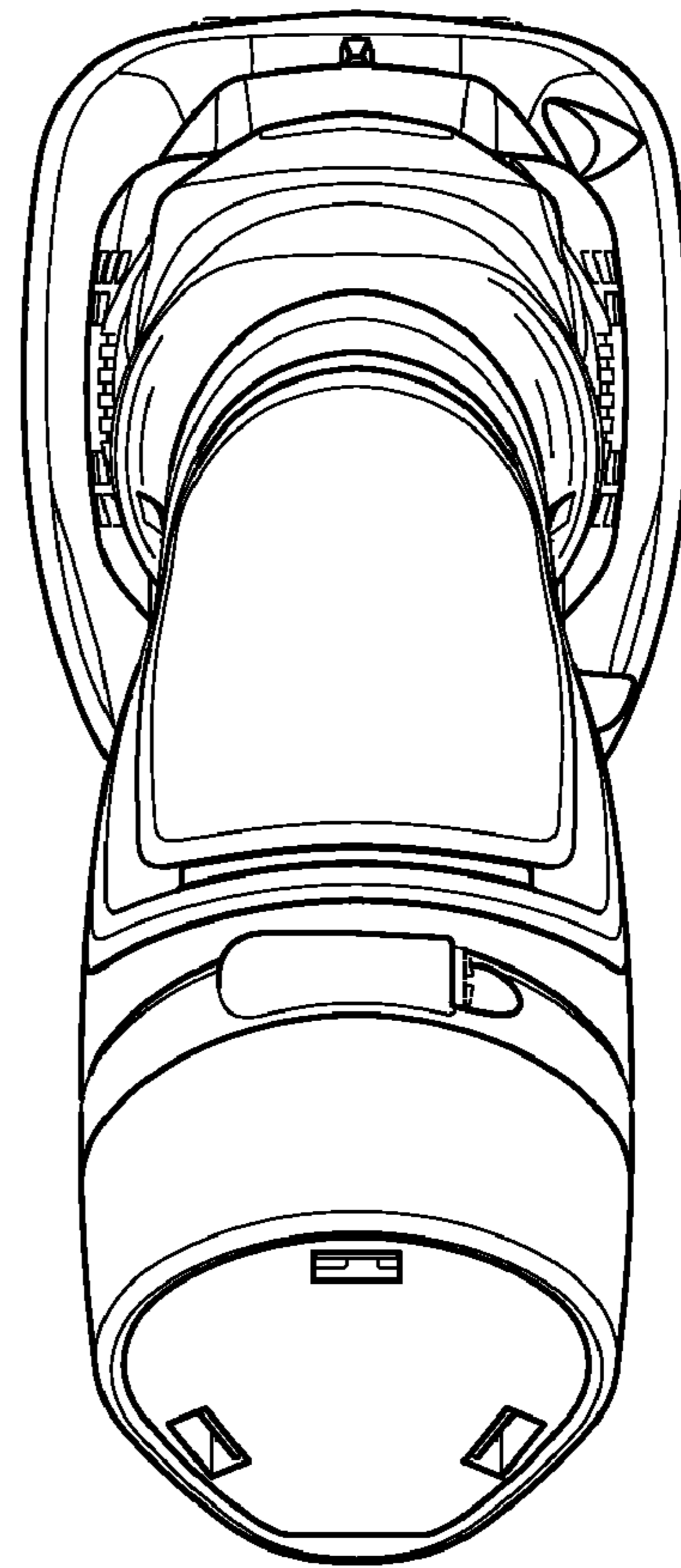

FIG. 7