



US00D638771S

(12) **United States Design Patent**  
**Chung**

(10) **Patent No.:** **US D638,771 S**

(45) **Date of Patent:** **\*\* May 31, 2011**

(54) **WHEEL**

(75) Inventor: **Suny Chung**, Yorba Linda, CA (US)

(73) Assignee: **Wheel Pros, LLC**, Lakewood, CO (US)

(\*\*) Term: **14 Years**

(21) Appl. No.: **29/379,389**

(22) Filed: **Nov. 18, 2010**

(51) **LOC (9) Cl.** ..... **12-16**

(52) **U.S. Cl.** ..... **D12/211**

(58) **Field of Classification Search** ..... D12/204-213;  
301/37.101, 64.101, 65, 64.201

See application file for complete search history.

(56) **References Cited**

**U.S. PATENT DOCUMENTS**

D506,717 S *	6/2005	Gallert	.....	D12/209
D524,220 S *	7/2006	Scheu	.....	D12/211
D533,826 S *	12/2006	Scheu		
D539,724 S *	4/2007	Muzzarelli		
D542,207 S *	5/2007	Gauffres		
D542,728 S *	5/2007	Ichinose		
D566,641 S *	4/2008	Fuligni et al.		
D581,853 S *	12/2008	Rak		
D582,335 S *	12/2008	Rak		
D589,428 S *	3/2009	Scheu		
D594,802 S *	6/2009	Gustafsson		
D609,623 S *	2/2010	Gallert		
D612,790 S *	3/2010	Tant et al.		
D623,115 S *	9/2010	Juergens et al.		
D629,346 S *	12/2010	Szews		

\* cited by examiner

*Primary Examiner* — Stacia Cadmus

(74) *Attorney, Agent, or Firm* — Garcia-Zamor IP Law; Ruy M. Garcia-Zamor

(57) **CLAIM**

The ornamental design for a wheel, as shown and described.

**DESCRIPTION**

FIG. 1 is a perspective view of a wheel according to a first preferred embodiment of my new design;  
 FIG. 2 is a front elevational view of the wheel of FIG. 1;  
 FIG. 3 is a left side elevational view of the wheel of FIG. 1, the right side elevational view of the wheel of FIG. 1 is a mirror image of FIG. 3;  
 FIG. 4 is a top plan view of the wheel of FIG. 1;  
 FIG. 5 is a bottom plan view of the wheel of FIG. 1;  
 FIG. 6 is a rear elevational view of the wheel of FIG. 1;  
 FIG. 7 is a perspective view of a wheel according to a second preferred embodiment of my new design;  
 FIG. 8 is a front elevational view of the wheel of FIG. 7;  
 FIG. 9 is a left side elevational view of the wheel of FIG. 7, the right side elevational view of the wheel of FIG. 7 is a mirror image of FIG. 9;  
 FIG. 10 is a top plan view of the wheel of FIG. 7;  
 FIG. 11 is a bottom plan view of the wheel of FIG. 7; and,  
 FIG. 12 is a rear elevational view of the wheel of FIG. 7.  
 The broken lines in FIGS. 1-12 represent environment and are for illustrative purposes only and do not constitute part of the claimed design.

**1 Claim, 10 Drawing Sheets**

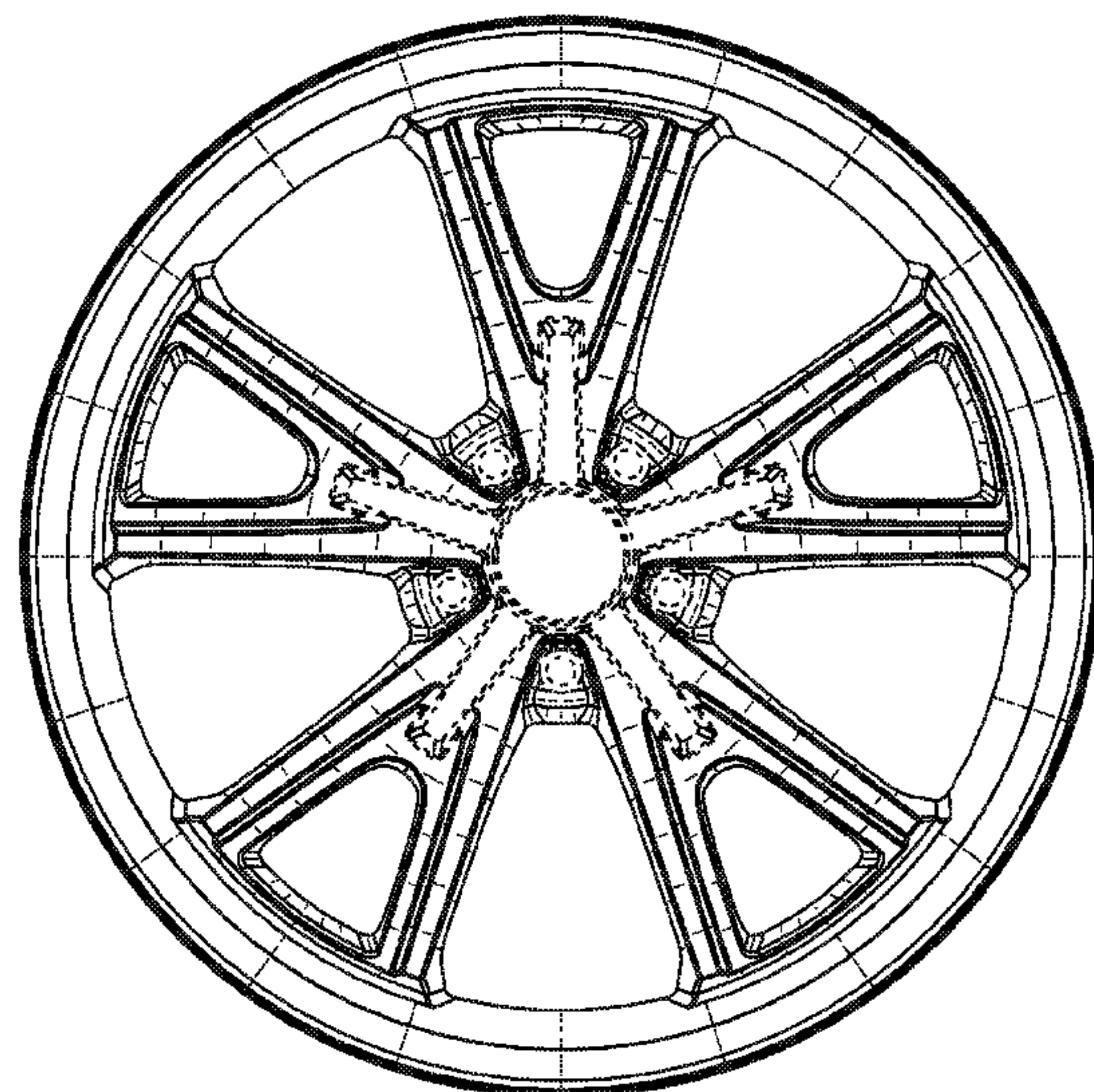
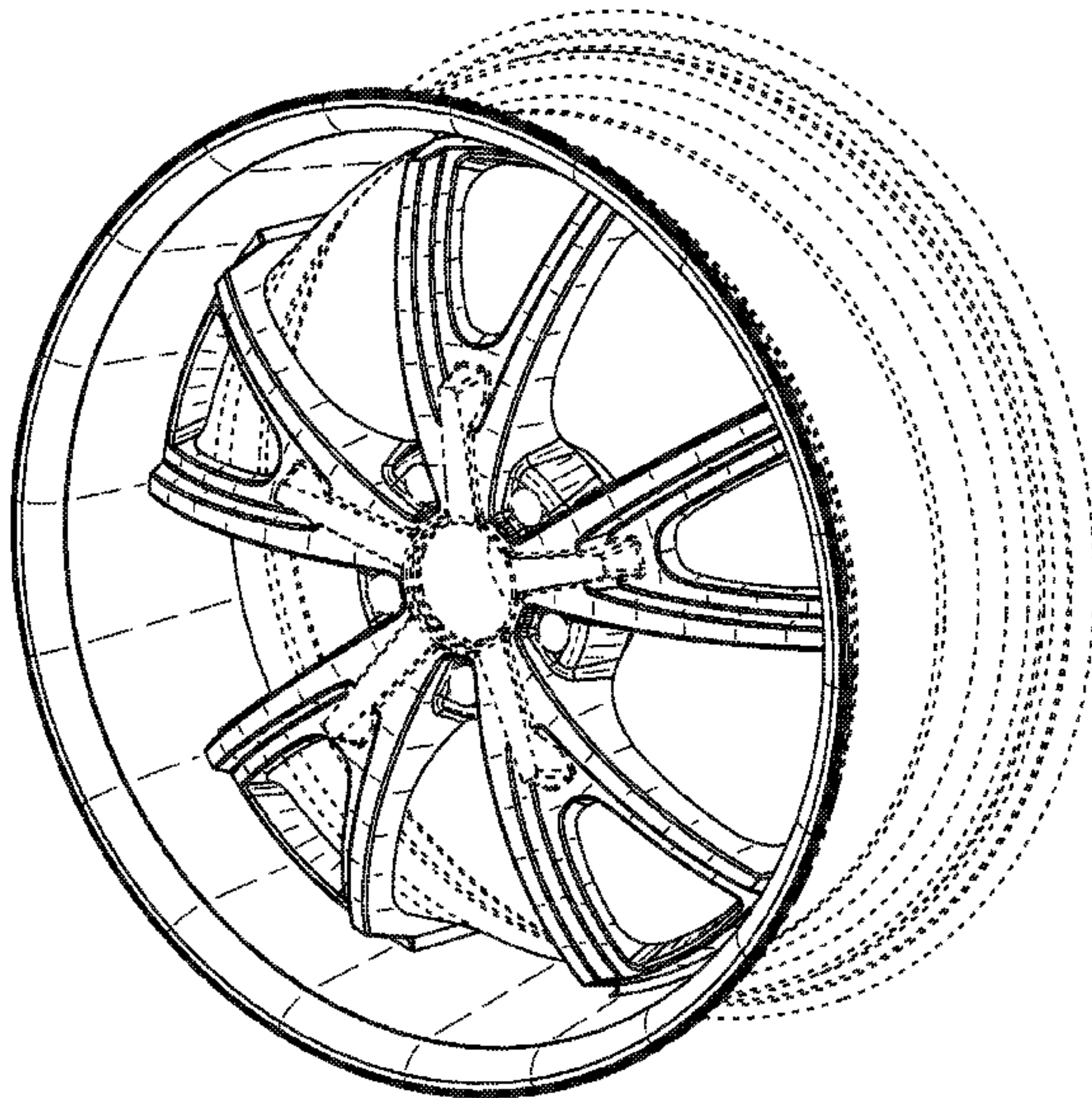



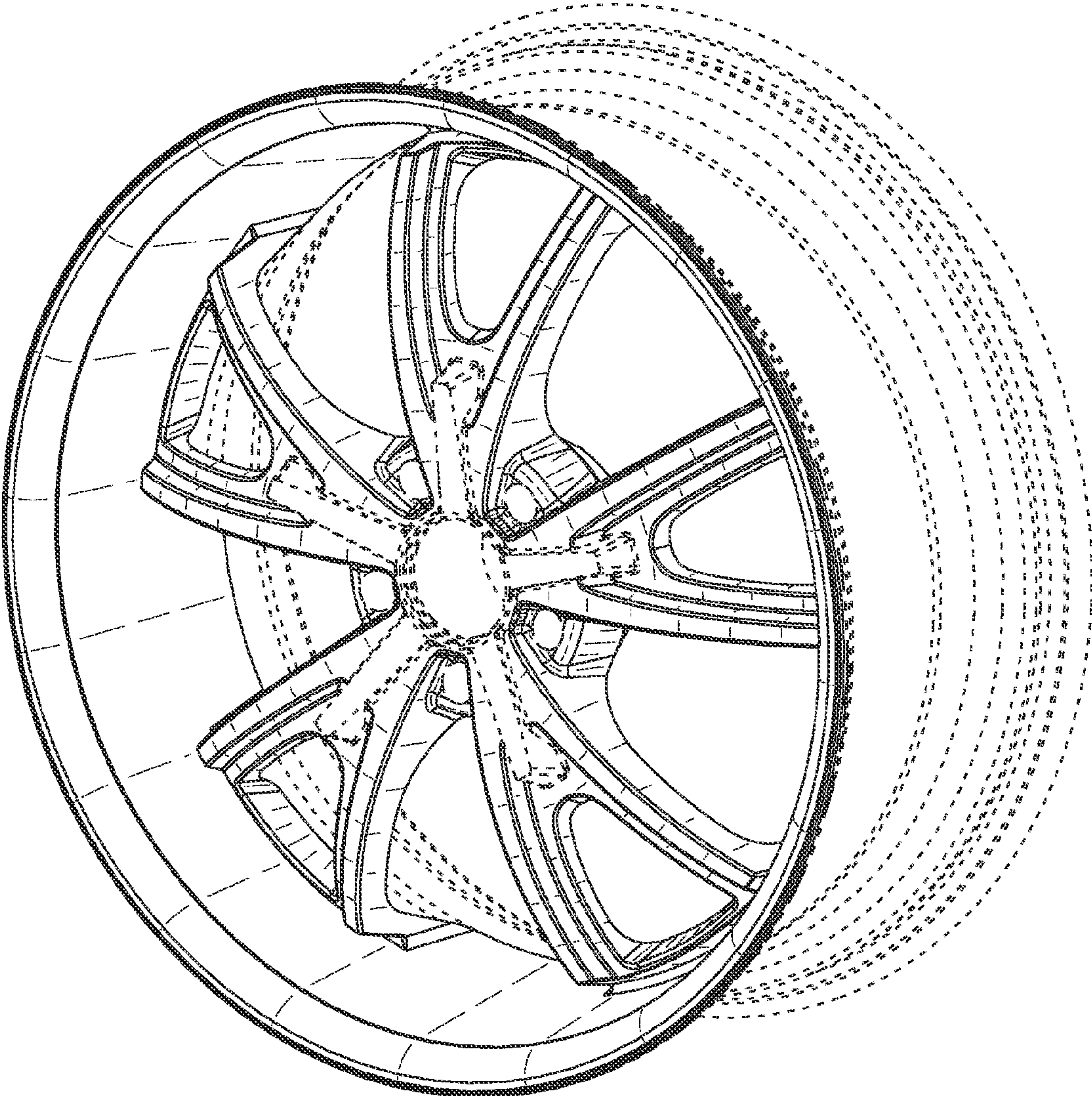

FIG. 1



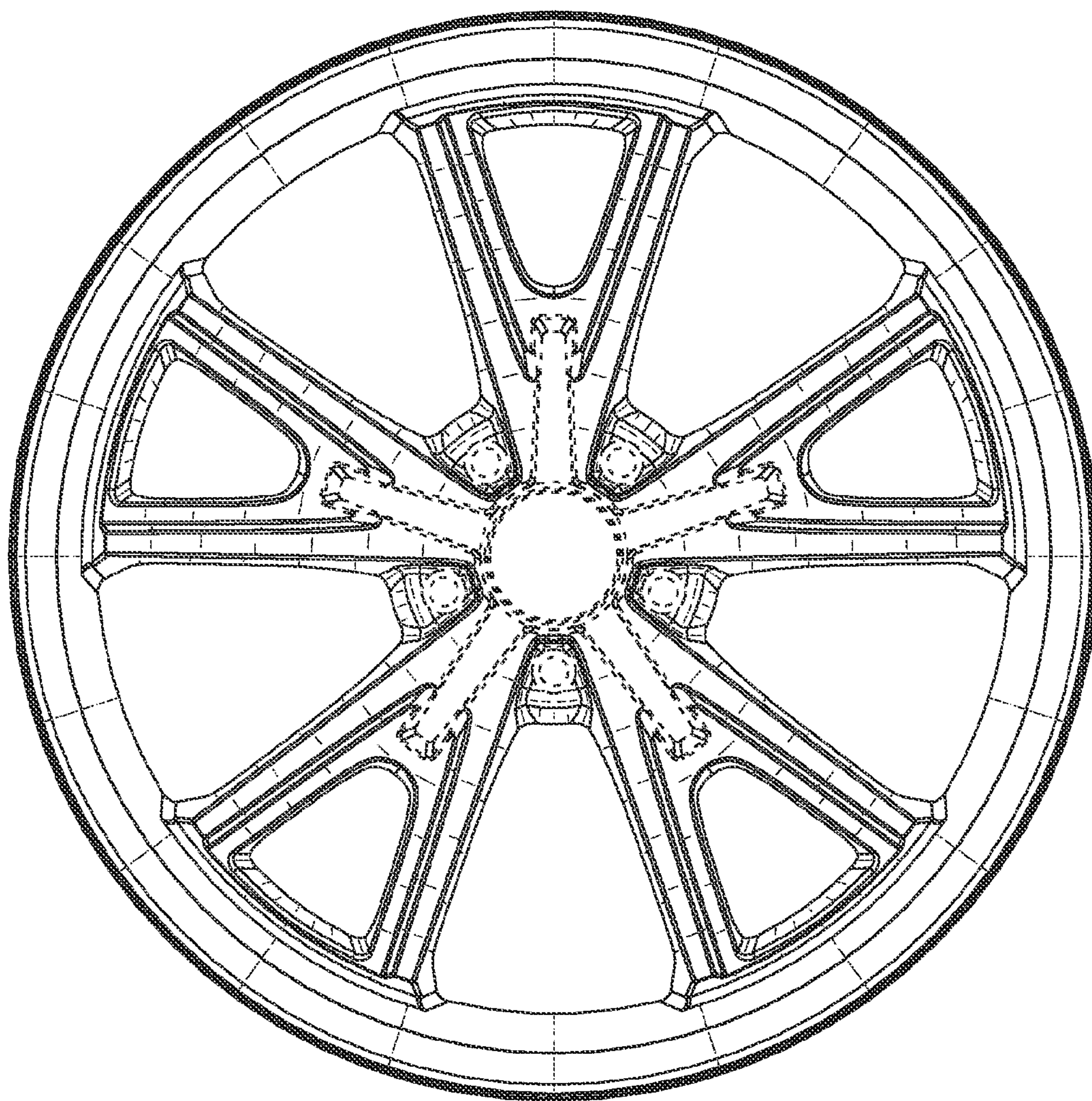

FIG. 2

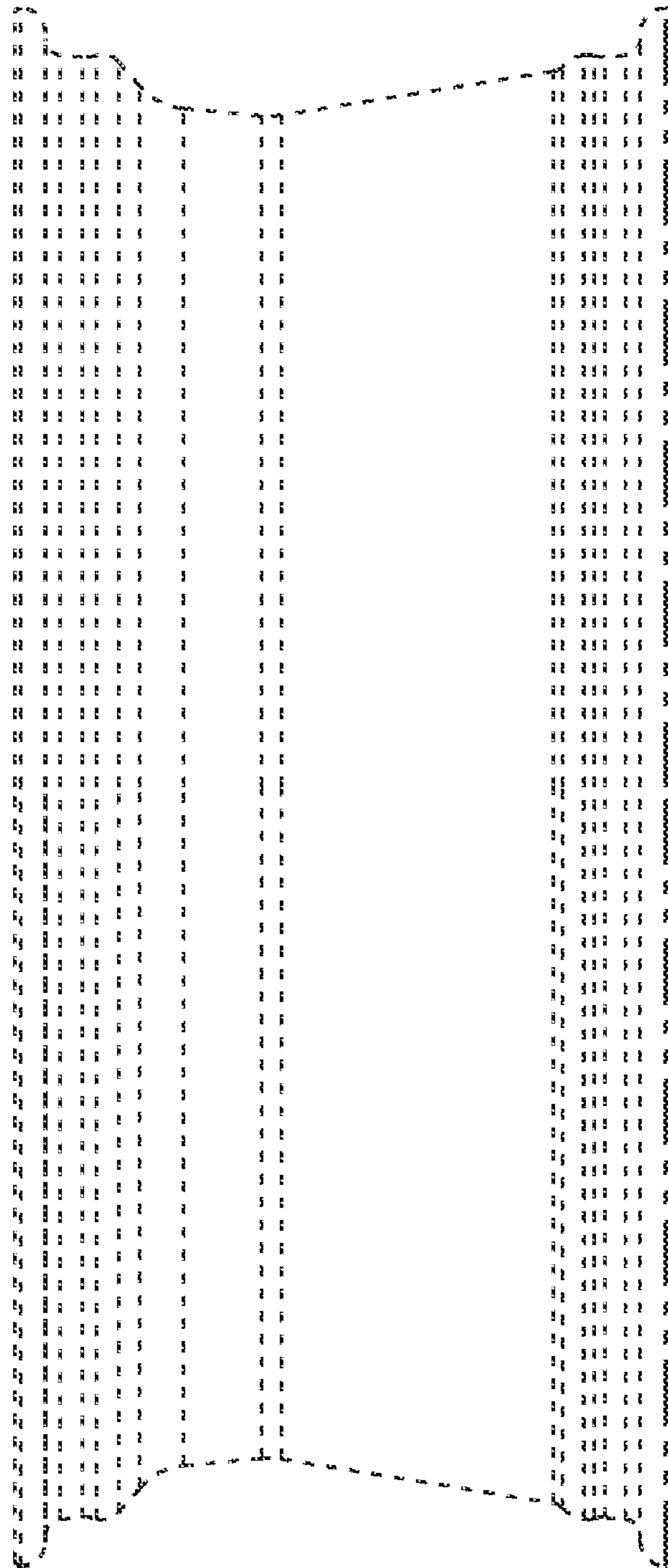

FIG. 3



FIG. 4

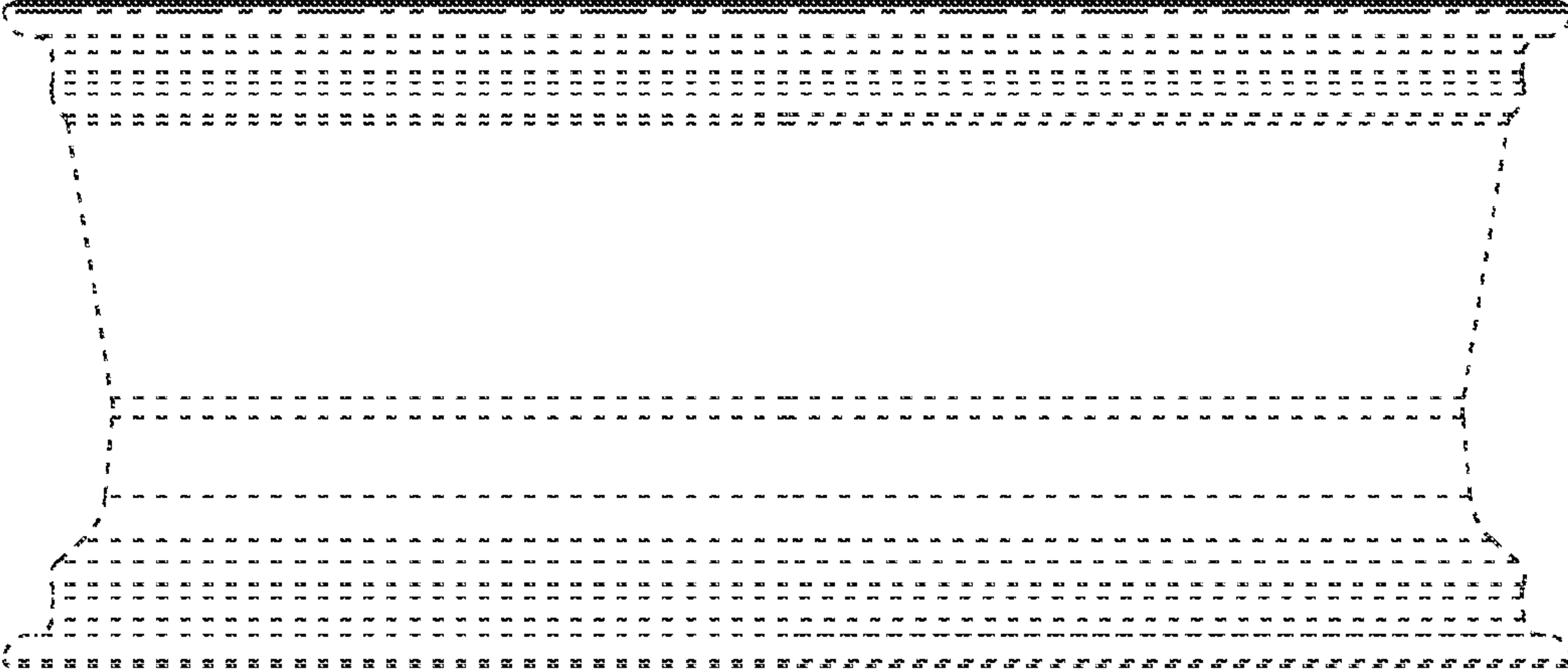

FIG. 5



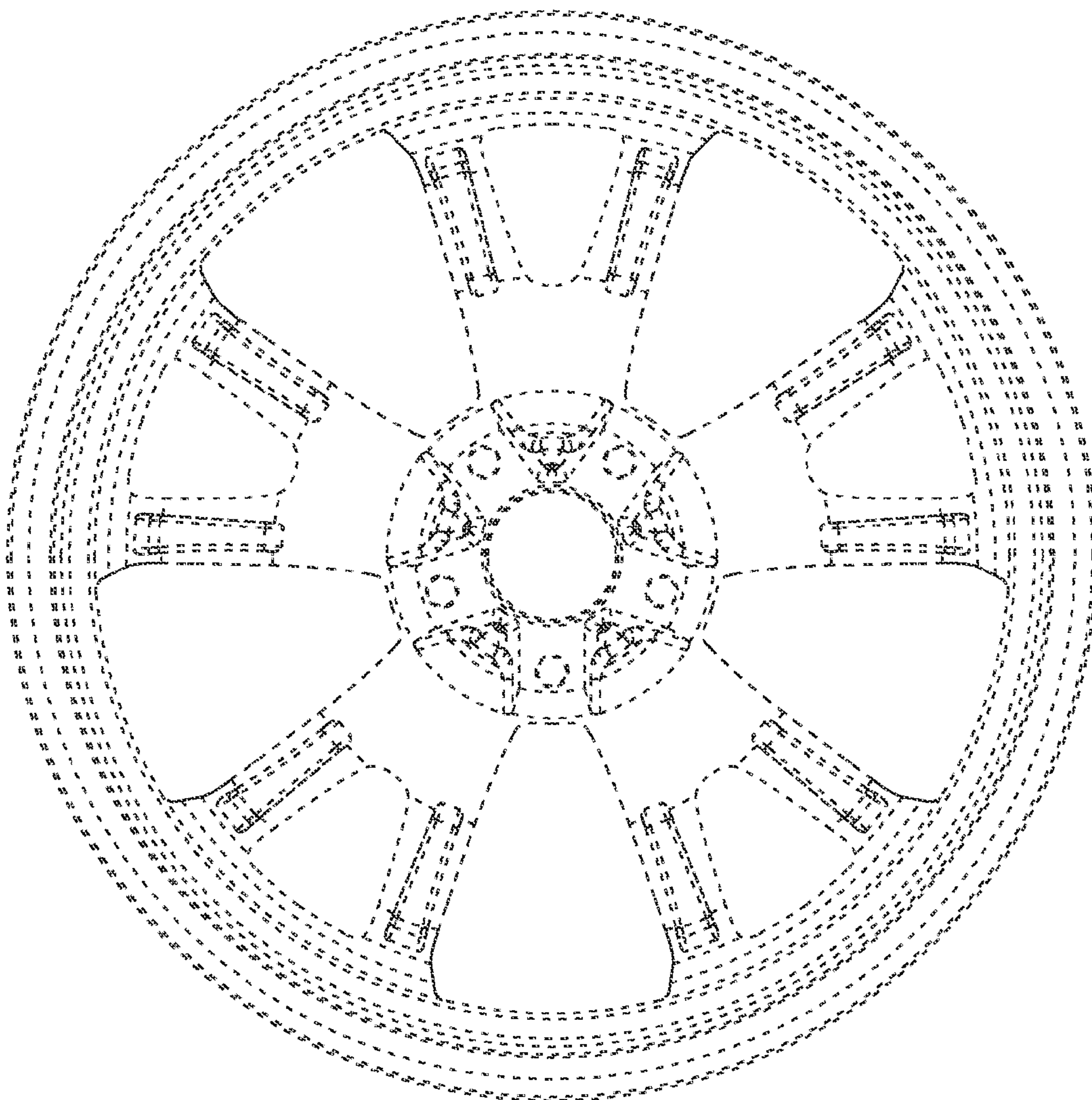

FIG. 6

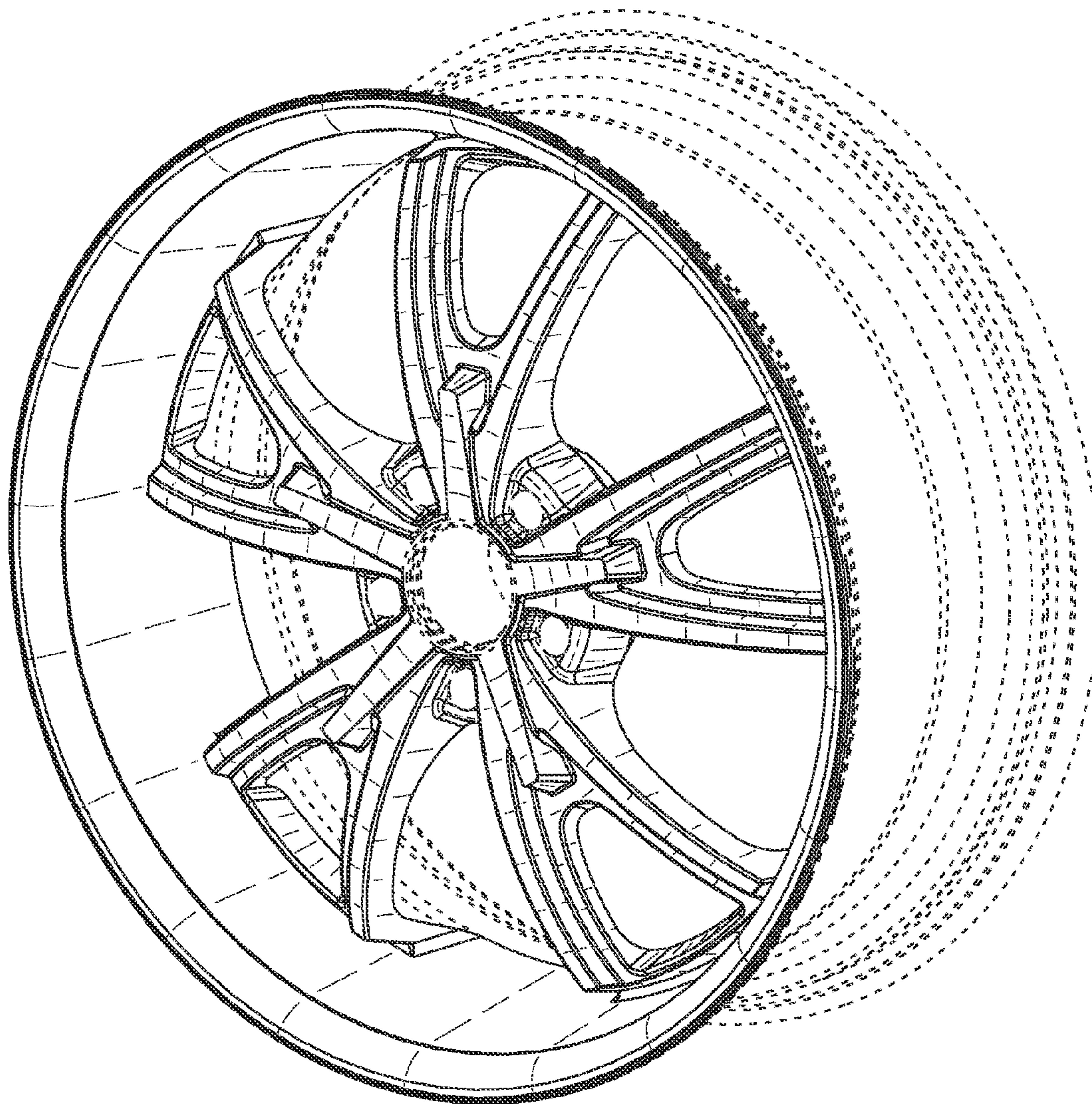

FIG. 7



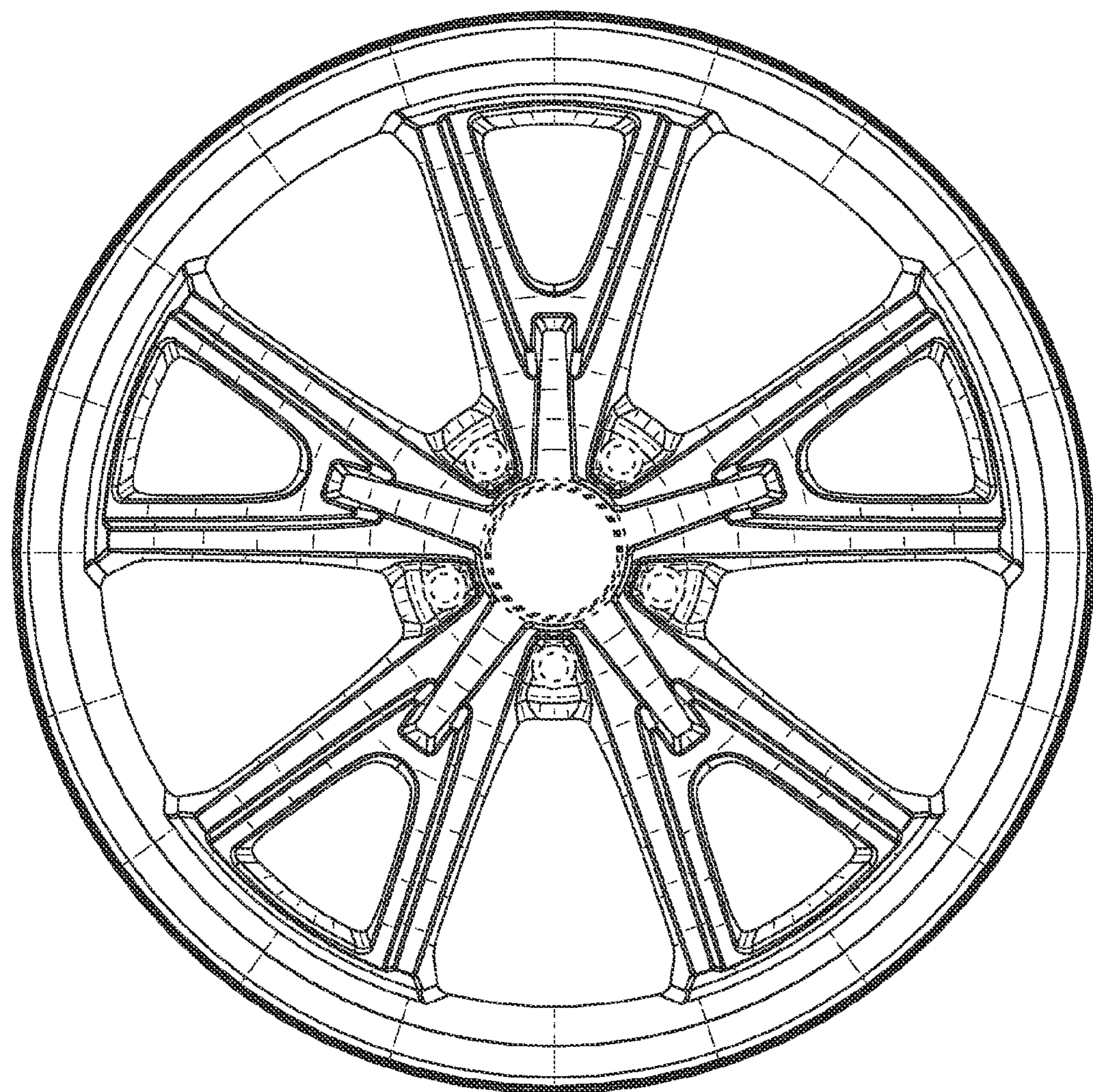

FIG. 8



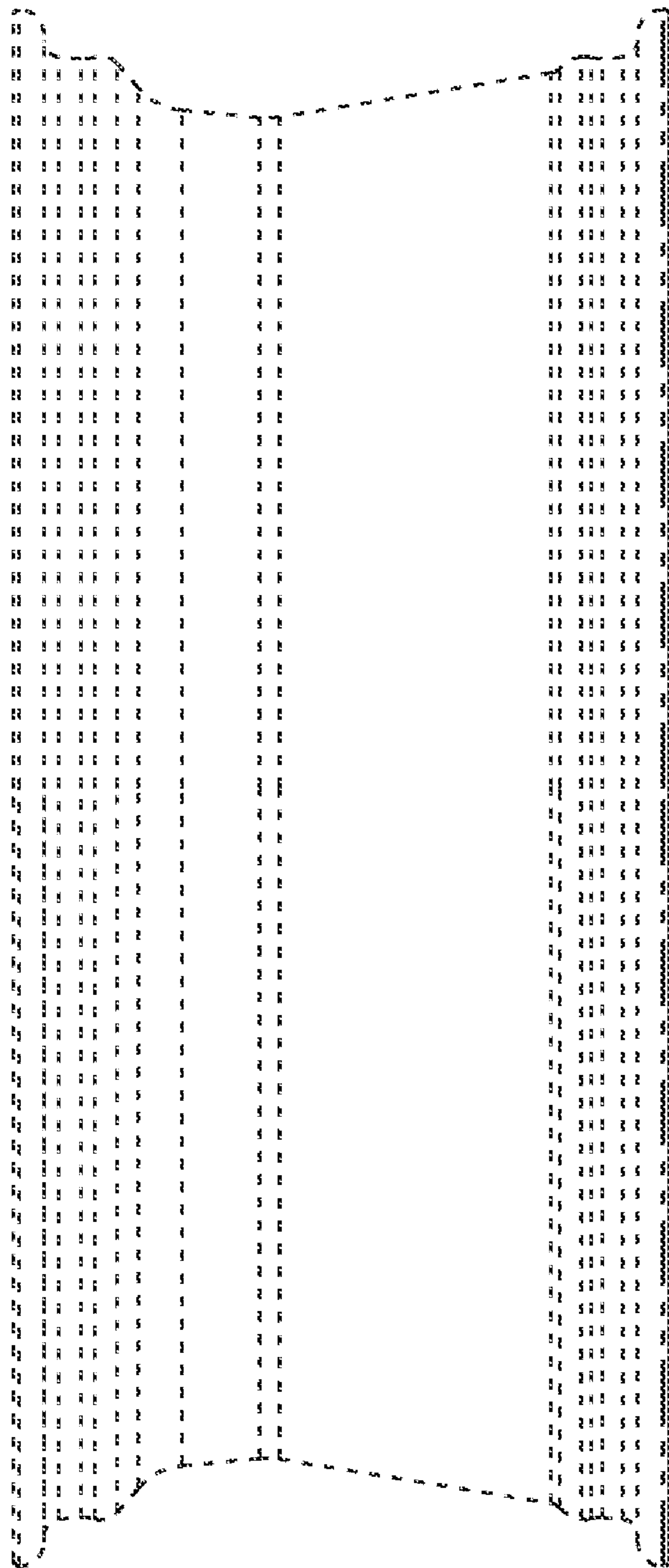

FIG. 9

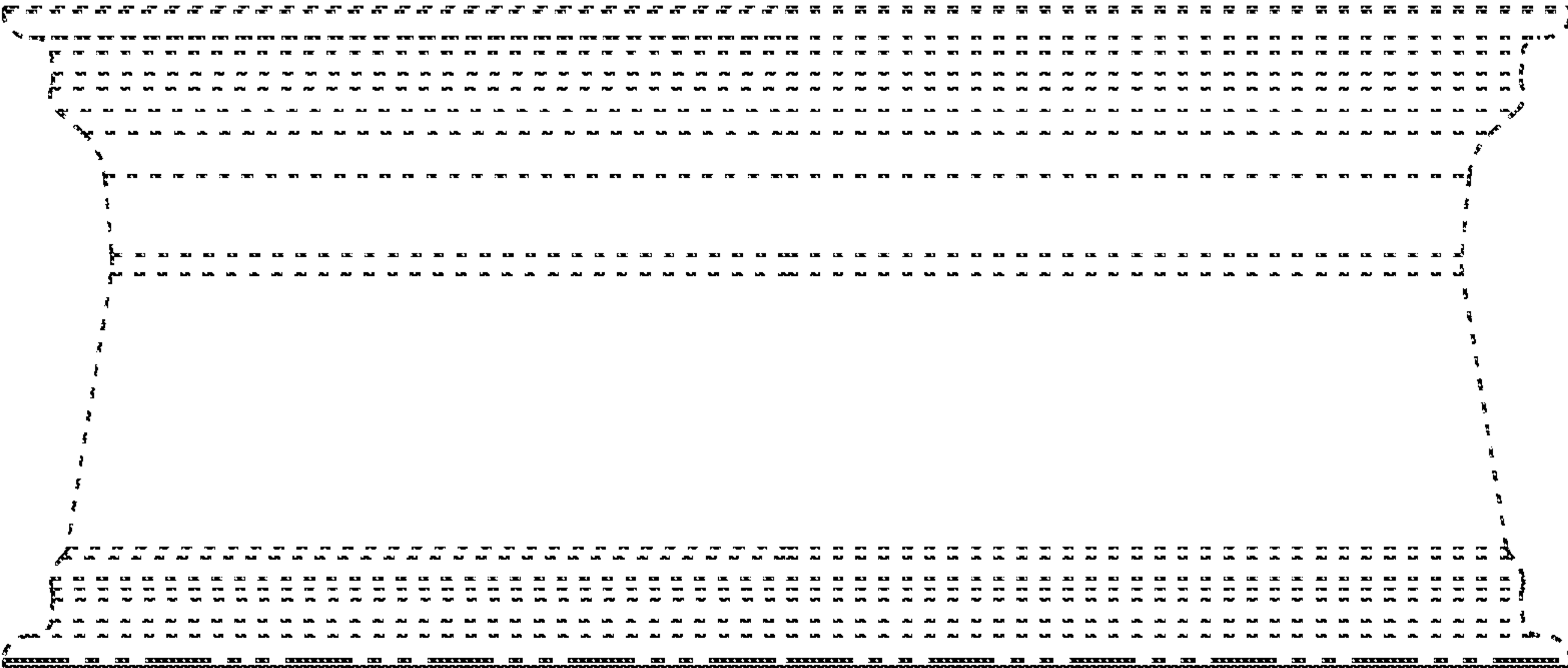

FIG. 10

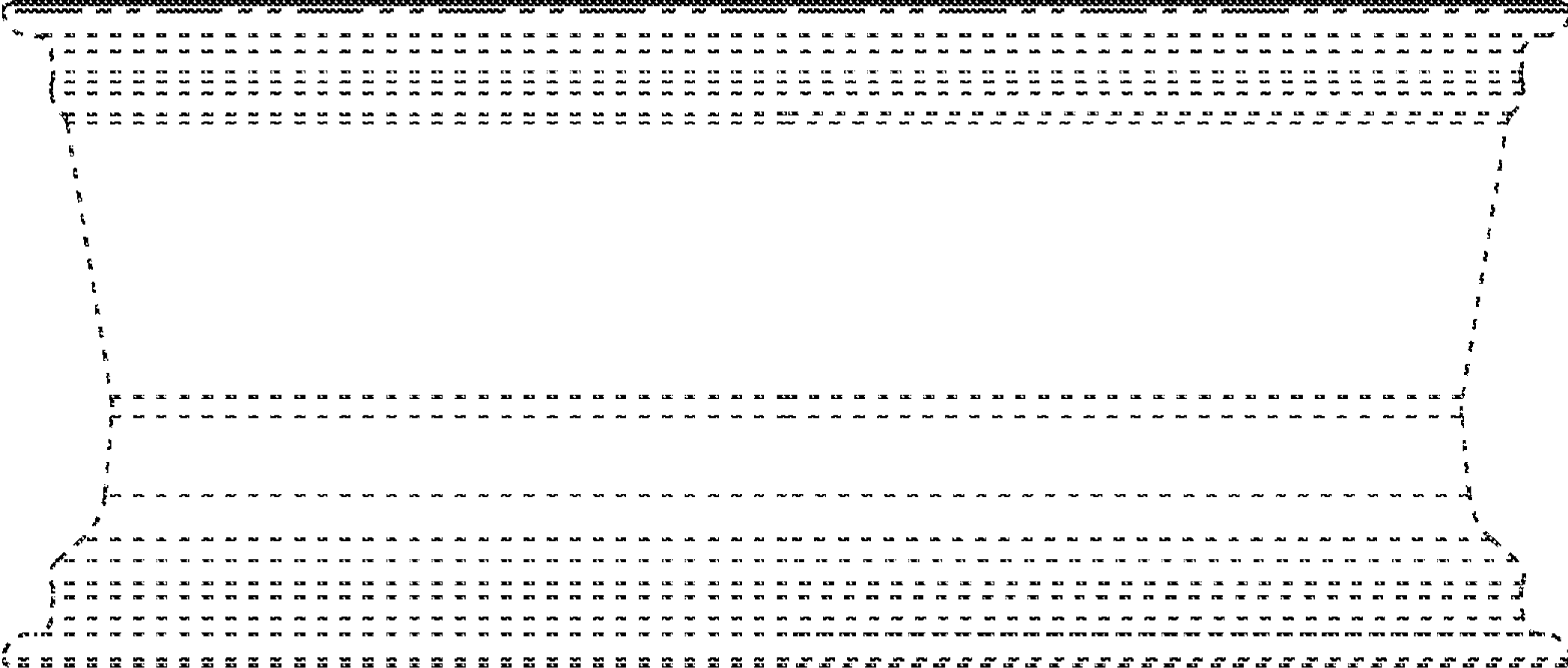

FIG. 11



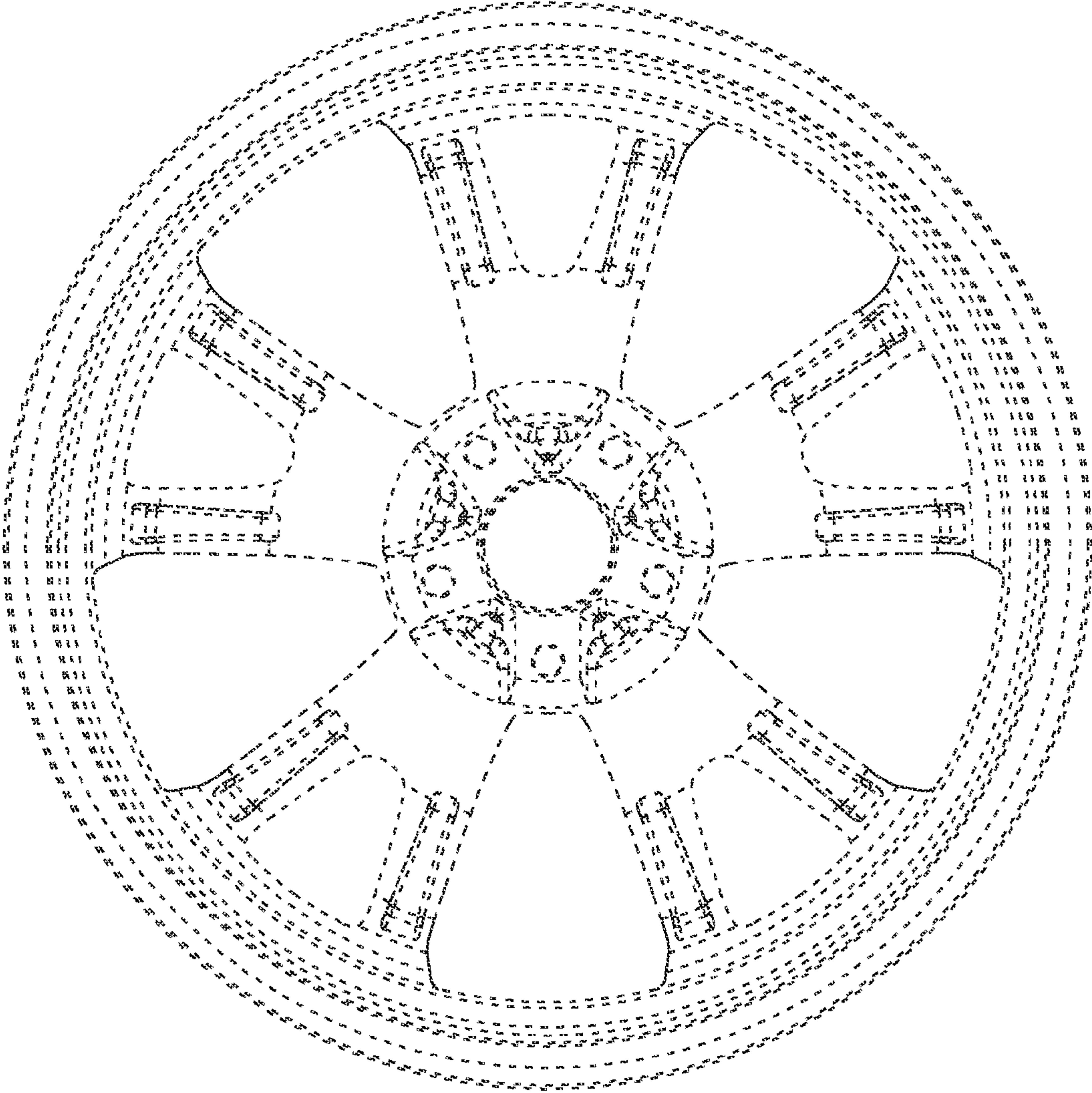

FIG. 12