



US00D638768S

(12) **United States Design Patent**
Nissl

(10) **Patent No.:** **US D638,768 S**

(45) **Date of Patent:** **** May 31, 2011**

(54) **WHEEL OR WHEEL COVER**

(75) **Inventor:** **Florian Dieter Nissl, Munich (DE)**

(73) **Assignee:** **Bayerische Motoren Werke
Aktiengesellschaft, Munich (DE)**

(**) **Term:** **14 Years**

(21) **Appl. No.:** **29/371,121**

(22) **Filed:** **Oct. 27, 2010**

(30) **Foreign Application Priority Data**

Apr. 28, 2010 (DE) 402010002511

(51) **LOC (9) Cl.** **12-16**

(52) **U.S. Cl.** **D12/211**

(58) **Field of Classification Search** D12/204-213;
301/37.101, 64.101, 65, 64.201

See application file for complete search history.

(56) **References Cited**

U.S. PATENT DOCUMENTS

D392,611 S *	3/1998	Echazabal et al.	D12/211
D402,951 S	12/1998	Wechner	
D447,993 S *	9/2001	Neeper	D12/211
D451,463 S *	12/2001	Murkett et al.	D12/209
D456,333 S	4/2002	Pollmann	
D494,917 S *	8/2004	Pollmann	D12/211
D499,371 S *	12/2004	Koch	D12/211
D513,727 S *	1/2006	Gallert	D12/211
D522,954 S	6/2006	Hueller	
D535,241 S *	1/2007	Kim	D12/211
D566,642 S *	4/2008	Scheu	D12/211
D568,800 S	5/2008	Huet	
D617,716 S *	6/2010	Lamm et al.	D12/211
D618,607 S *	6/2010	Hilpert	D12/211
D620,870 S *	8/2010	Powell	D12/211
D624,862 S *	10/2010	Zhao	D12/209
D628,136 S	11/2010	Leclercq	

FOREIGN PATENT DOCUMENTS

DE	M9704929.8	11/1997
DE	40010998.0	3/2001
EM	000398052-0002	8/2006
EM	000754593-0005	9/2007
EM	000624812-0002	3/2008
EM	001693599-0005	4/2010
EM	001744640-0002	8/2010
EM	001744640-0008	8/2010
EM	001754953-0004	9/2010
EM	001684507-0005	10/2010
EM	001636978-0012	11/2010

* cited by examiner

Primary Examiner — Stacia Cadmus

(74) *Attorney, Agent, or Firm* — Crowell & Moring LLP

(57) **CLAIM**

The ornamental design for a wheel or wheel cover, as shown and described.

DESCRIPTION

This application contains subject matter related to the following co-pending U.S. design patent applications:

Application Ser. No. 29/347,963, filed Aug. 20, 2010 and entitled "Wheel or Wheel Cover;"

Application Ser. No. 29/347,967, filed Aug. 20, 2010 and entitled "Wheel or Wheel Cover;" and

Application Ser. No. 29/375,312, filed Sep. 21, 2010 and entitled "Wheel or Wheel Cover."

FIG. 1 is a front view of a wheel or wheel cover according to my design; and,

FIG. 2 is a perspective view thereof.

The broken line showing of the rear of the rim and the bolt holes and the center cap in the central hub area is included for the purpose of illustrating environment and forms no part of the claimed design.

1 Claim, 1 Drawing Sheet

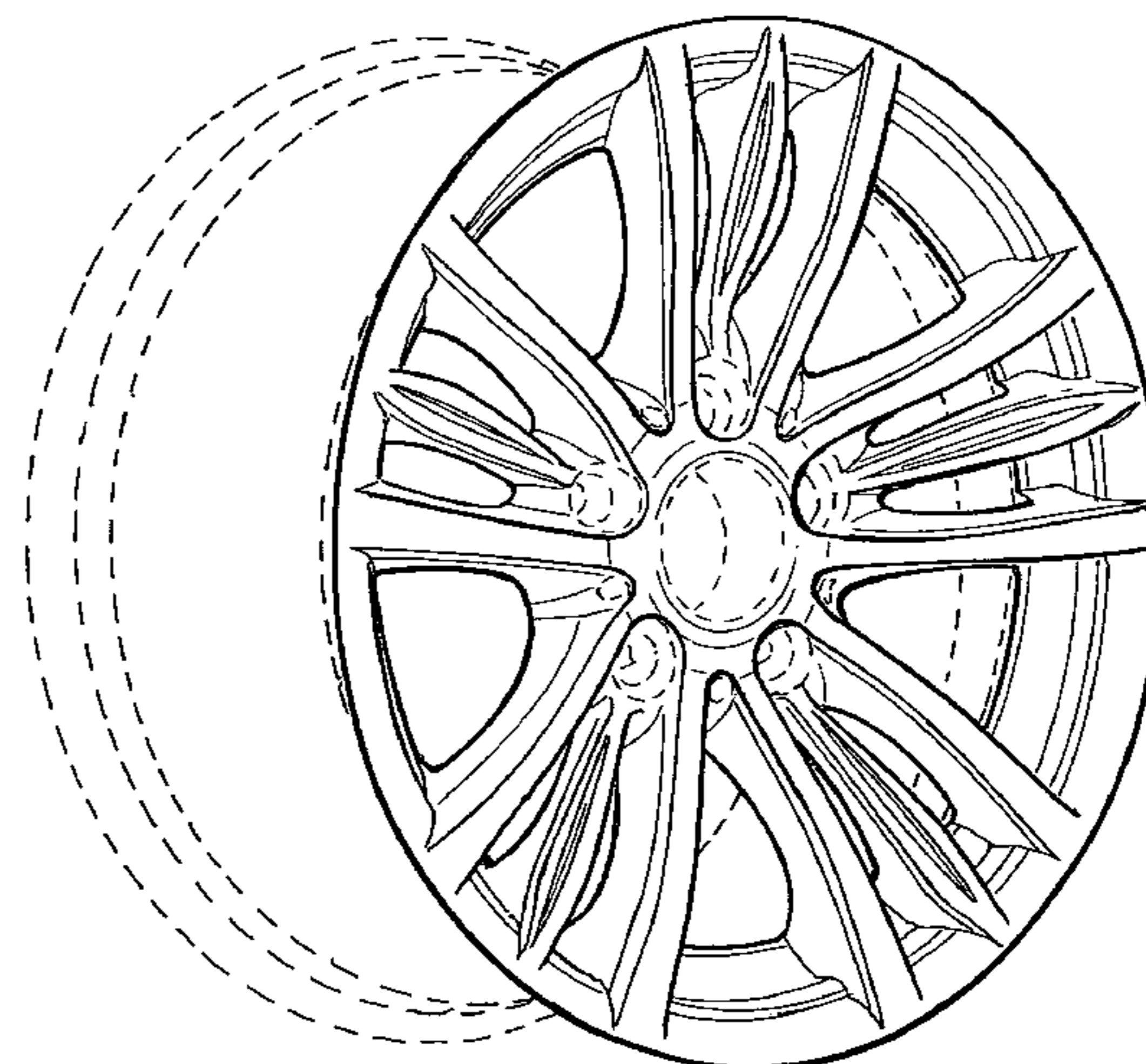
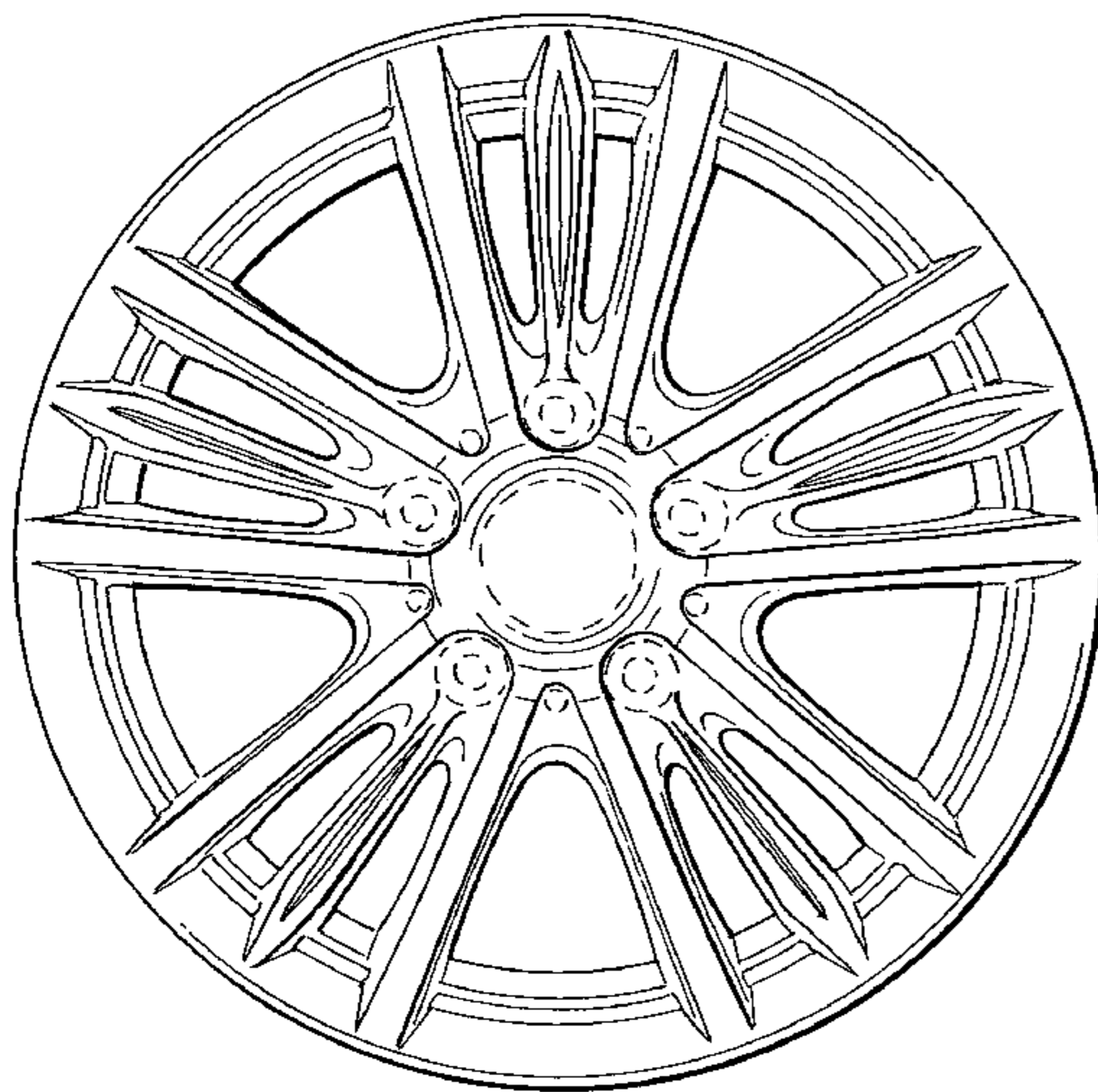

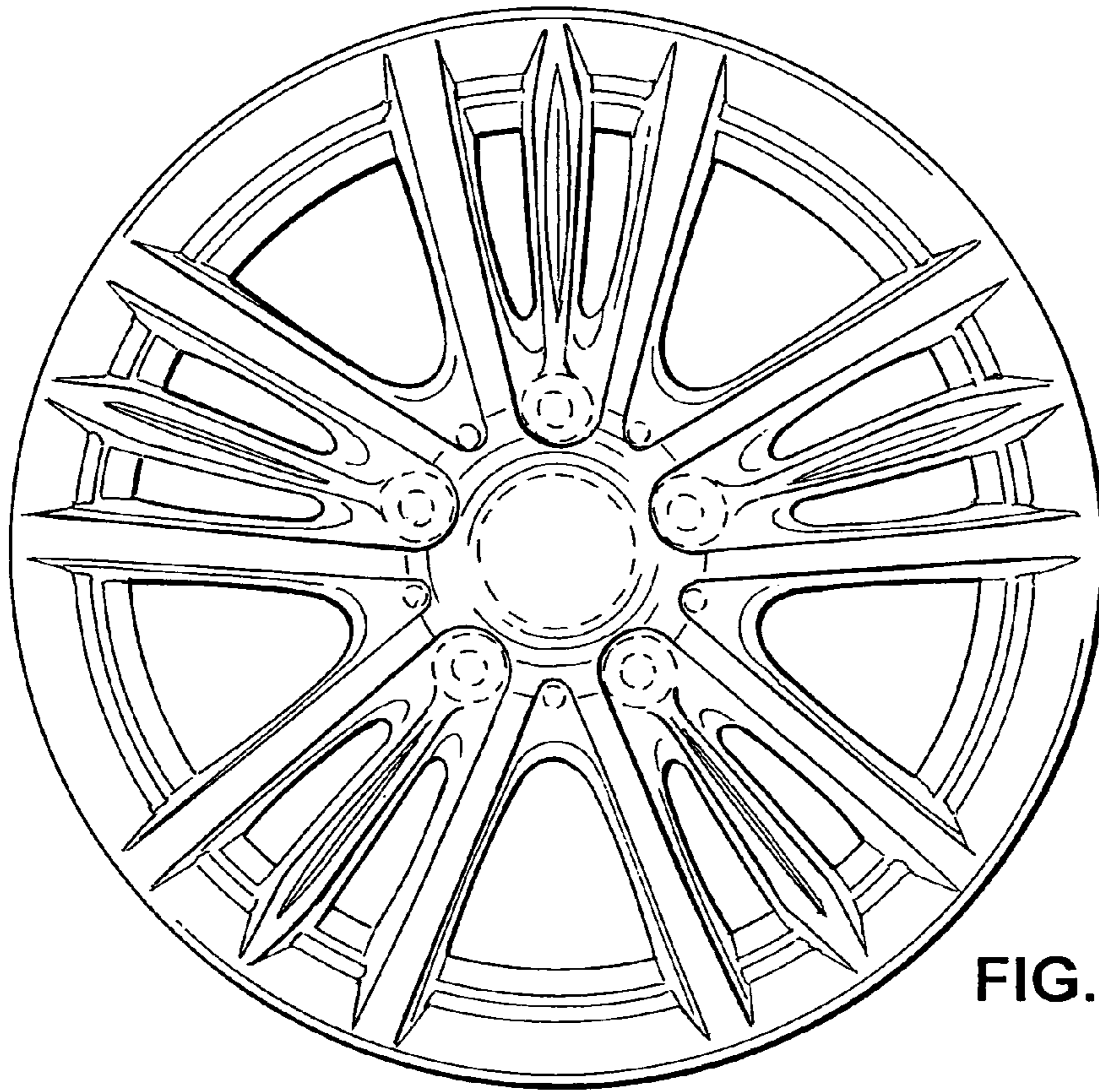

FIG. 1

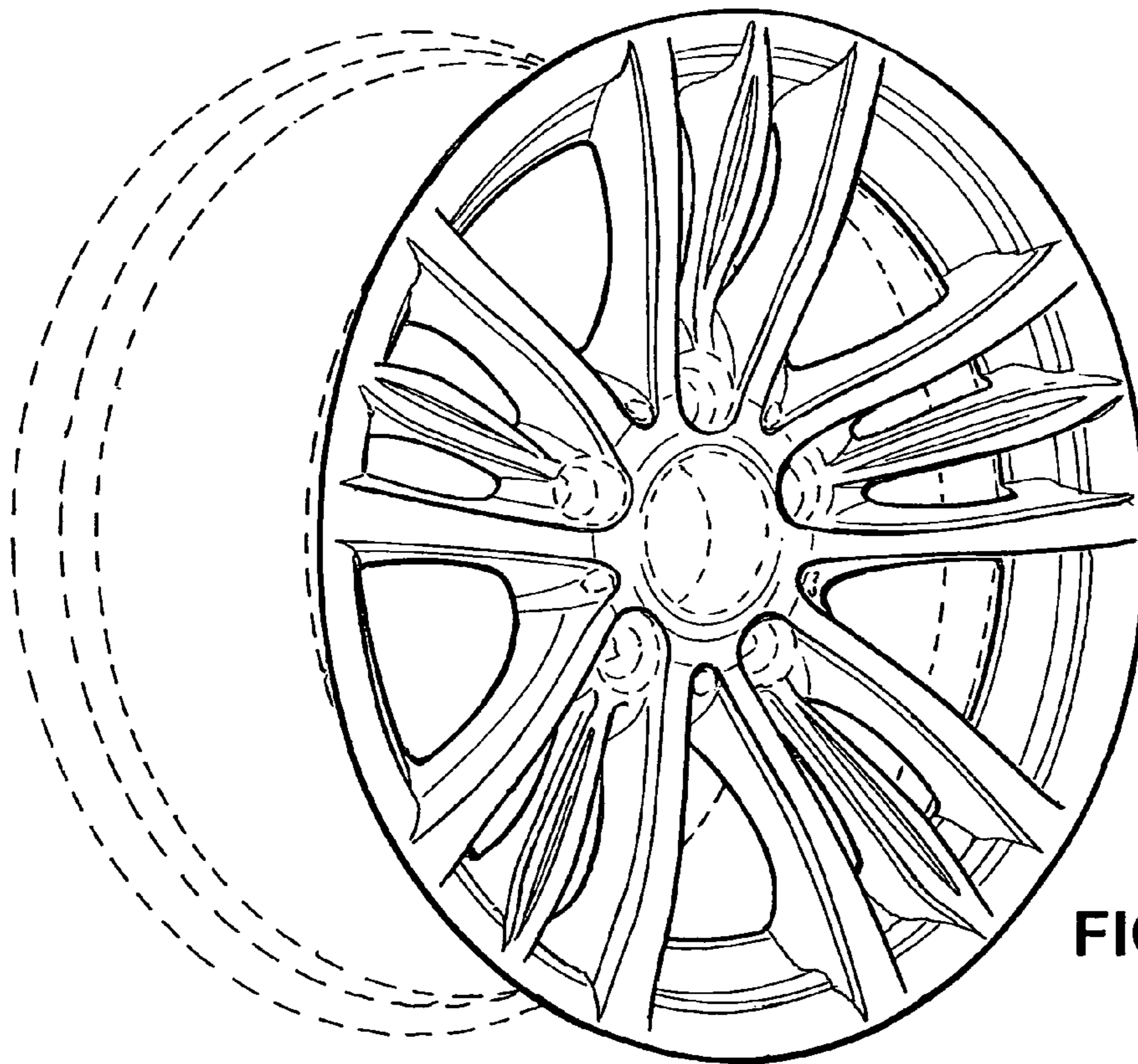

FIG. 2