



US00D638761S

(12) **United States Design Patent**
De Wind

(10) **Patent No.:** **US D638,761 S**

(45) **Date of Patent:** **** May 31, 2011**

(54) **VEHICULAR ELECTRO-OPTIC MIRROR ASSEMBLY**

(75) Inventor: **Darryl P. De Wind**, West Olive, MI (US)

(73) Assignee: **Magna Mirrors of America, Inc.**, Holland, MI (US)

(**) Term: **14 Years**

(21) Appl. No.: **29/383,443**

(22) Filed: **Jan. 18, 2011**

Related U.S. Application Data

(63) Continuation-in-part of application No. 29/375,886, filed on Sep. 29, 2010, now Pat. No. Des. 633,423.

(51) **LOC (9) Cl.** **12-16**

(52) **U.S. Cl.** **D12/187**

(58) **Field of Classification Search** D12/187, D12/188, 189; D6/300, 309; 359/838, 841-844, 359/868, 871, 604, 881, 514, 866; 248/475.1, 248/479-483

See application file for complete search history.

(56) **References Cited**

U.S. PATENT DOCUMENTS

5,669,698	A *	9/1997	Veldman et al.	362/494
5,671,996	A *	9/1997	Bos et al.	362/488
6,499,850	B2	12/2002	Waldmann	
D493,131	S	7/2004	Lawlor et al.	
D493,394	S	7/2004	Lawlor et al.	
6,983,920	B2 *	1/2006	DeLine	248/481
7,110,156	B2	9/2006	Lawlor et al.	
7,532,149	B2	5/2009	Banko et al.	
7,710,631	B2	5/2010	McCabe et al.	
7,821,697	B2 *	10/2010	Varaprasad et al.	359/267
2002/0097494	A1 *	7/2002	Waldmann	359/603
2008/0266389	A1 *	10/2008	DeWind et al.	348/115
2009/0207514	A1 *	8/2009	McCabe et al.	359/871
2009/0213480	A1	8/2009	Li	
2009/0237821	A1 *	9/2009	Li	359/844
2009/0244740	A1	10/2009	Takayanagi et al.	

2010/0085645	A1	4/2010	Skiver et al.	
2010/0091394	A1 *	4/2010	Dewind et al.	359/838
2010/0290141	A1 *	11/2010	Huang	359/844

* cited by examiner

FOREIGN PATENT DOCUMENTS

WO W02010124064 10/2010

Primary Examiner — Caron D Veynar

Assistant Examiner — Katrina Kile

(74) *Attorney, Agent, or Firm* — Van Dyke, Gardner, Linn & Burkhart, LLP

(57) **CLAIM**

The ornamental designs for a vehicular electro-optic mirror assembly, as shown and described.

DESCRIPTION

FIG. 1 is a front perspective view of a vehicular electro-optic mirror assembly in accordance with the present invention; FIG. 2 is a rear perspective view of the vehicular electro-optic mirror assembly of FIG. 1; FIG. 3 is a front elevation of the vehicular electro-optic mirror assembly of FIG. 1; FIG. 4 is a rear elevation of the vehicular electro-optic mirror assembly of FIG. 1; FIG. 5 is a side elevation of the vehicular electro-optic mirror assembly of FIG. 1; FIG. 6 is an opposite side elevation of the vehicular electro-optic mirror assembly of FIG. 1; FIG. 7 is a top plan view of the vehicular electro-optic mirror assembly of FIG. 1; FIG. 8 is a bottom plan view of the vehicular electro-optic mirror assembly of FIG. 1; FIG. 9 is a front perspective view of a second embodiment of a vehicular electro-optic mirror assembly in accordance with the present invention; FIG. 10 is a rear perspective view of the vehicular electro-optic mirror assembly of FIG. 9; FIG. 11 is a front elevation of the vehicular electro-optic mirror assembly of FIG. 9; FIG. 12 is a rear elevation of the vehicular electro-optic mirror assembly of FIG. 9;

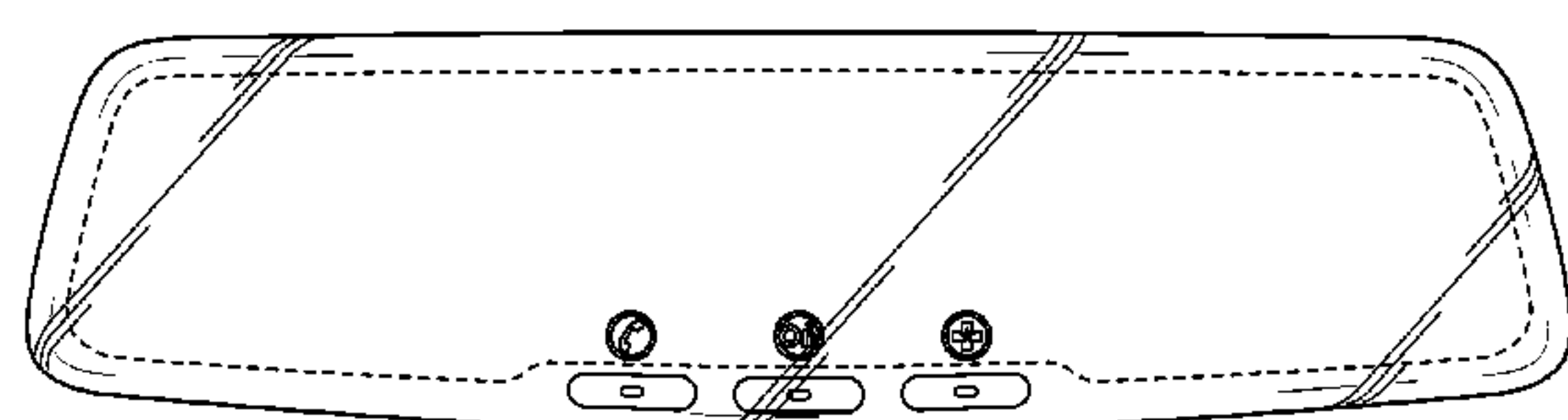
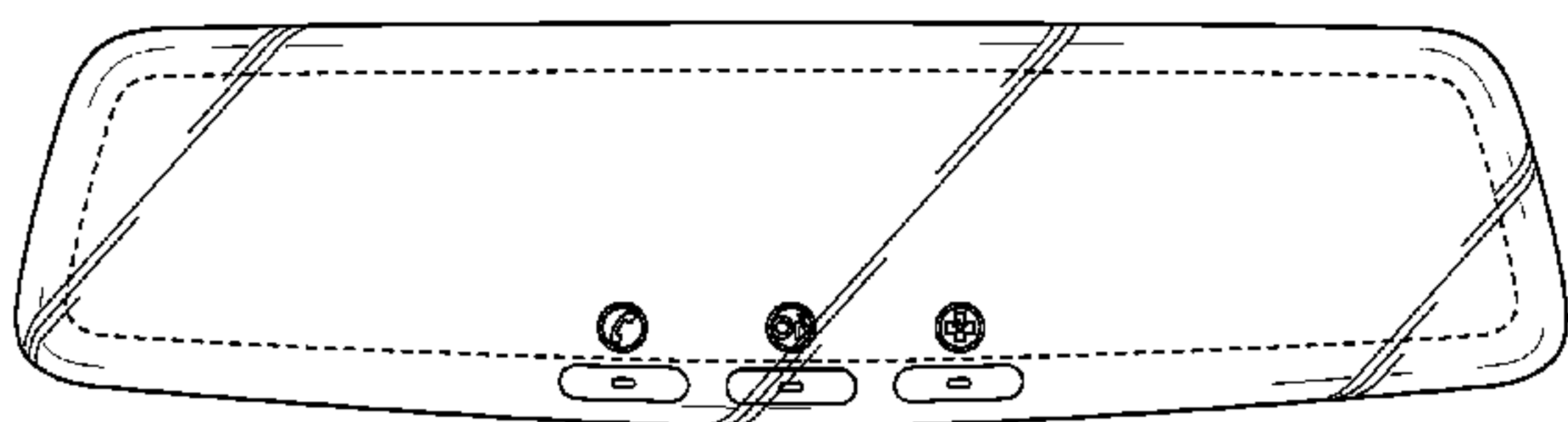

FIG. 13 is a side elevation of the vehicular electro-optic mirror assembly of FIG. 9;

FIG. 14 is an opposite side elevation of the vehicular electro-optic mirror assembly of FIG. 9;

FIG. 15 is a top plan view of the vehicular electro-optic mirror assembly of FIG. 9;

FIG. 16 is a bottom plan view of the vehicular electro-optic mirror assembly of FIG. 9;

FIG. 17 is a front perspective view of a third embodiment of a vehicular electro-optic mirror assembly in accordance with the present invention;

FIG. 18 is a rear perspective view of the vehicular electro-optic mirror assembly of FIG. 17;

FIG. 19 is a front elevation of the vehicular electro-optic mirror assembly of FIG. 17;

FIG. 20 is a rear elevation of the vehicular electro-optic mirror assembly of FIG. 17;

FIG. 21 is a side elevation of the vehicular electro-optic mirror assembly of FIG. 17;

FIG. 22 is an opposite side elevation of the vehicular electro-optic mirror assembly of FIG. 17;

FIG. 23 is a top plan view of the vehicular electro-optic mirror assembly of FIG. 17;

FIG. 24 is a bottom plan view of the vehicular electro-optic mirror assembly of FIG. 17;

FIG. 25 is a front perspective view of a fourth embodiment of a vehicular electro-optic mirror assembly in accordance with the present invention;

FIG. 26 is a rear perspective view of the vehicular electro-optic mirror assembly of FIG. 25;

FIG. 27 is a front elevation of the vehicular electro-optic mirror assembly of FIG. 25;

FIG. 28 is a rear elevation of the vehicular electro-optic mirror assembly of FIG. 25;

FIG. 29 is a side elevation of the vehicular electro-optic mirror assembly of FIG. 25;

FIG. 30 is an opposite side elevation of the vehicular electro-optic mirror assembly of FIG. 25;

FIG. 31 is a top plan view of the vehicular electro-optic mirror assembly of FIG. 25; and,

FIG. 32 is a bottom plan view of the vehicular electro-optic mirror assembly of FIG. 25.

In the drawings, the broken lines in the figures depict portions of the design that form no part of the claim.

1 Claim, 20 Drawing Sheets

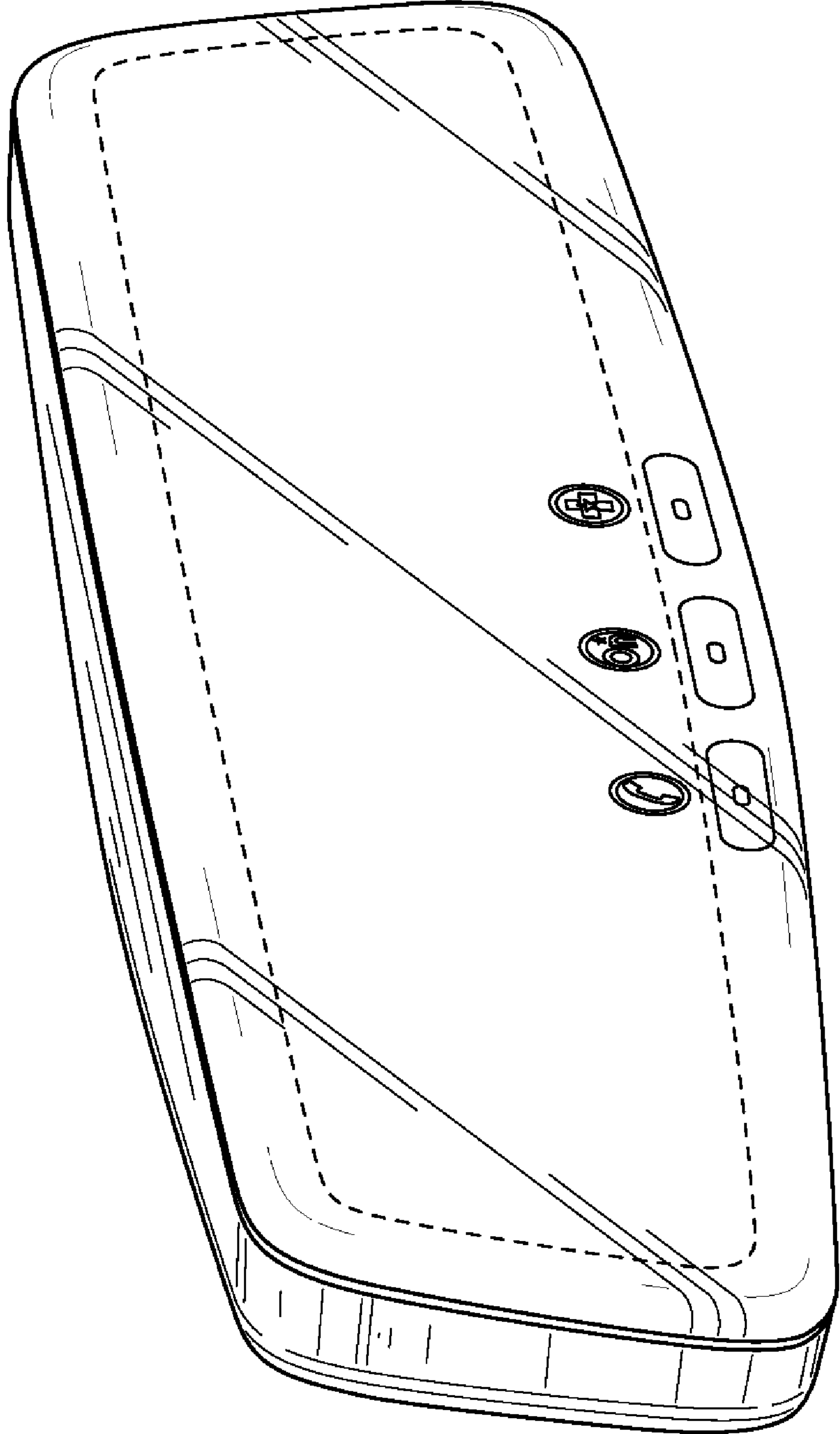

FIG. 1

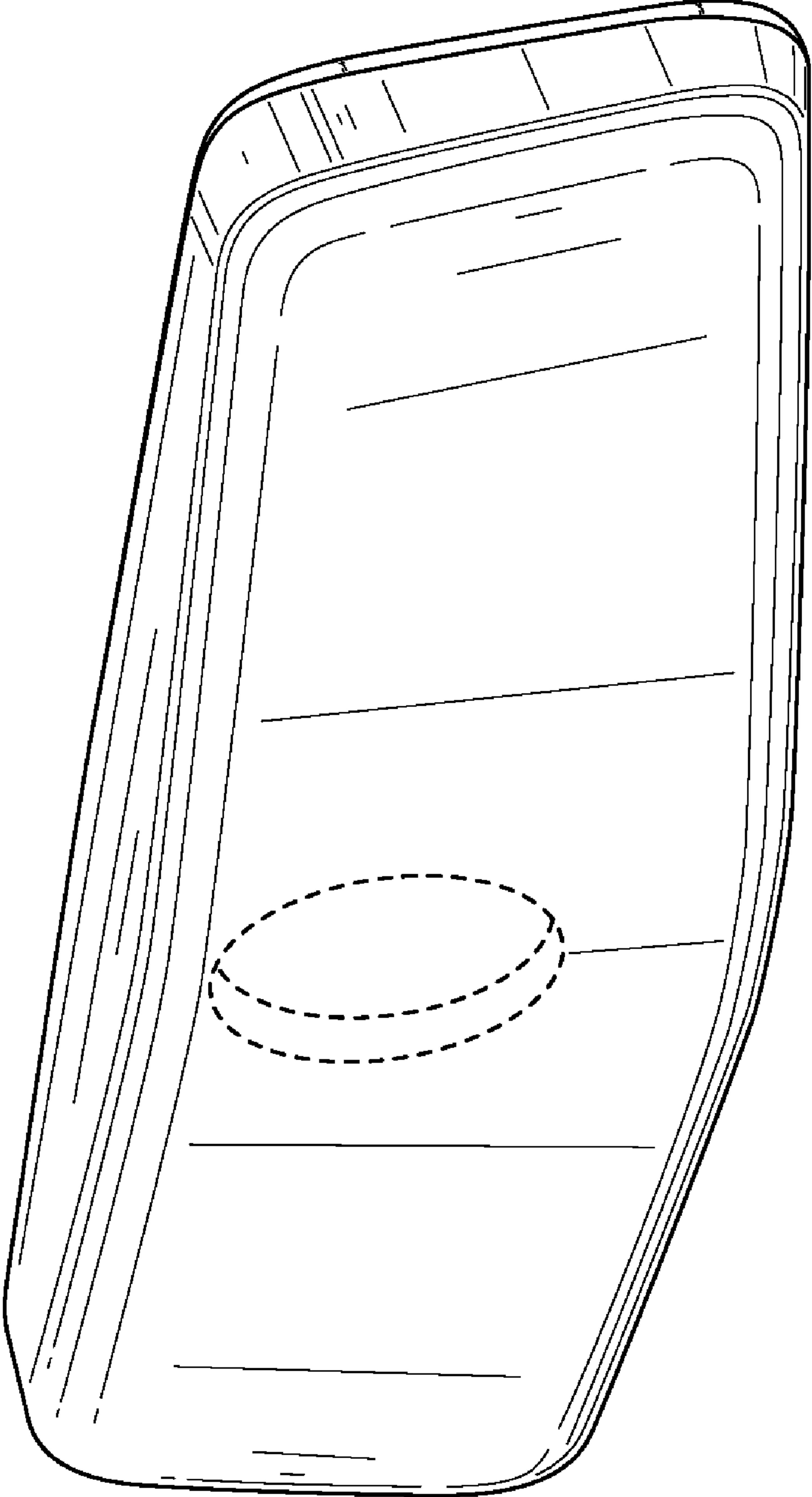

FIG. 2

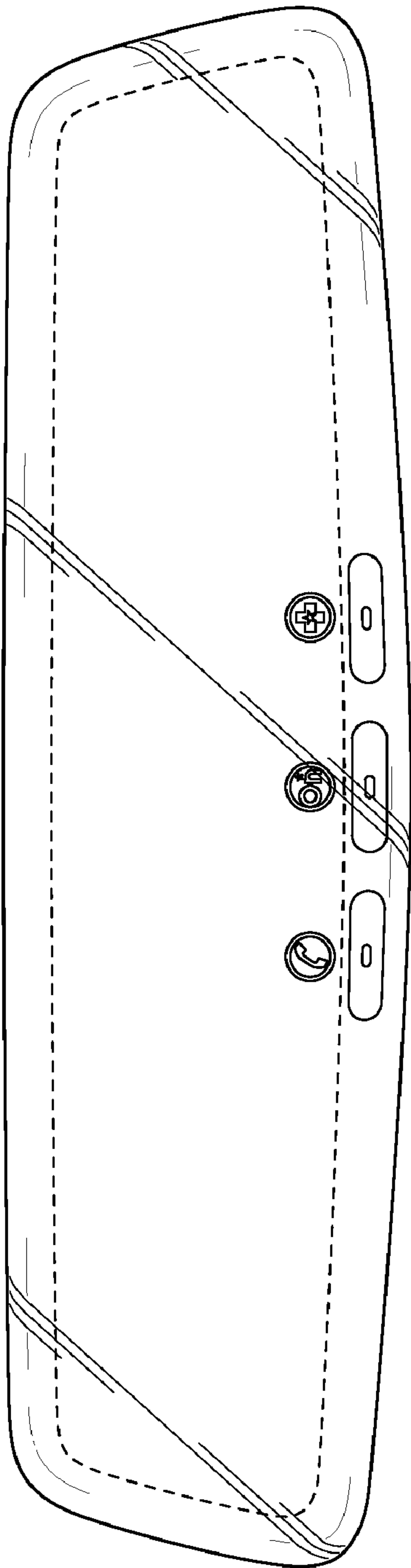

FIG. 3

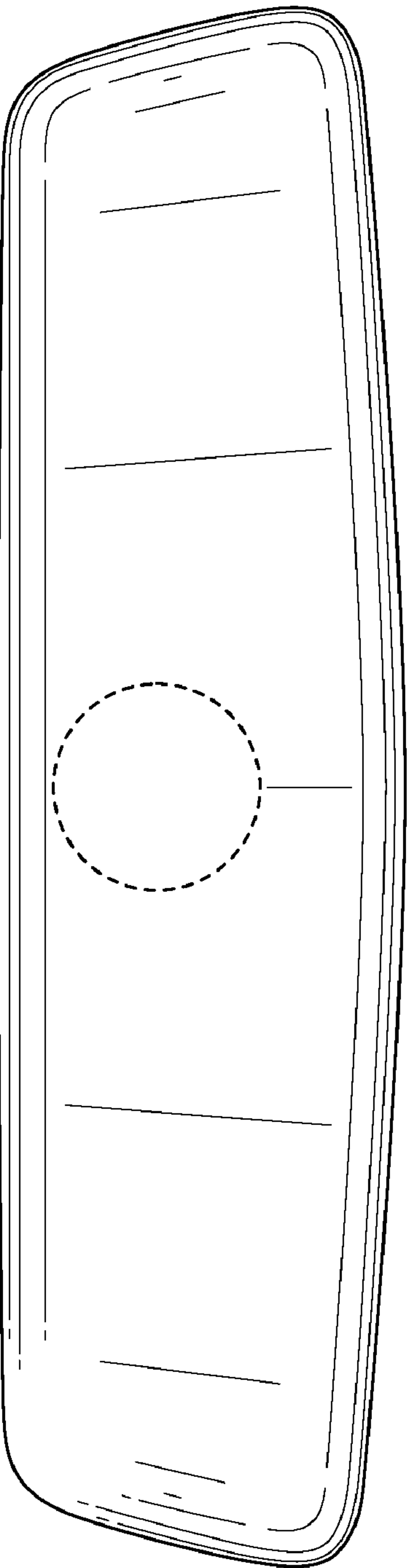

FIG. 4

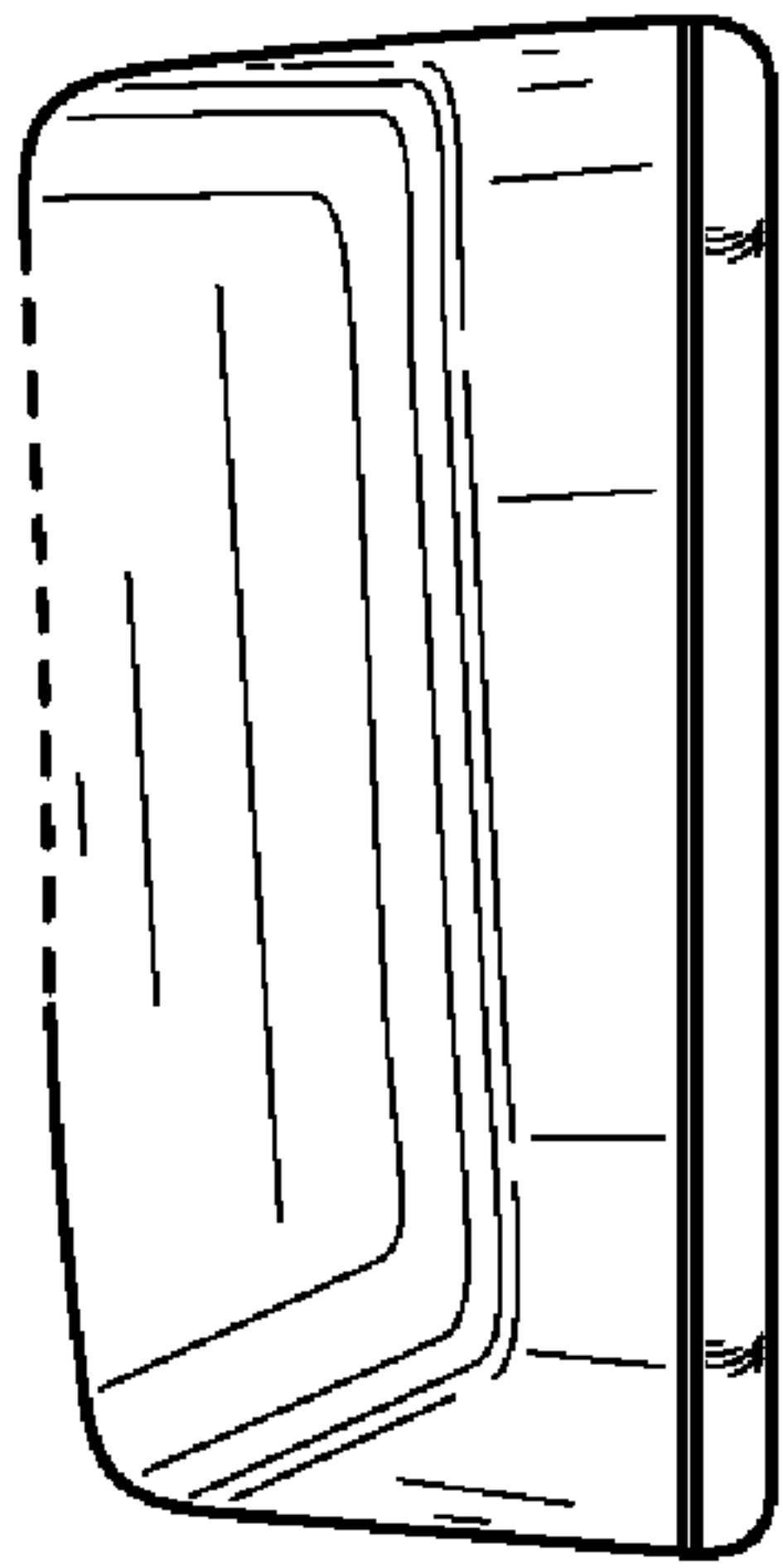

FIG. 5

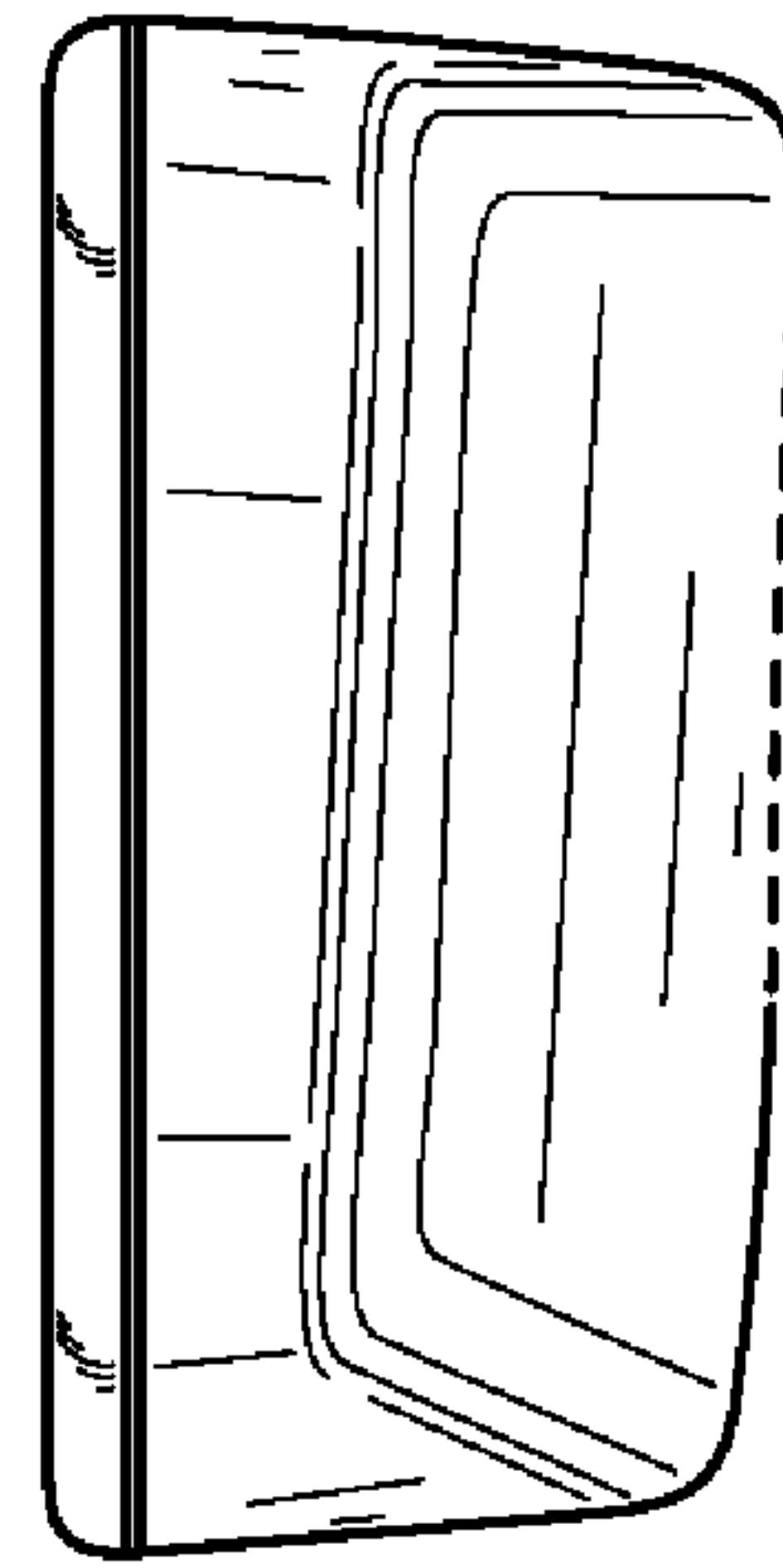

FIG. 6

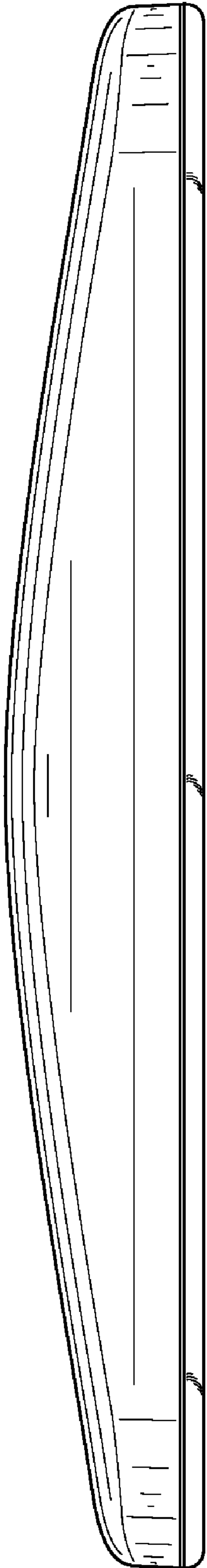

FIG. 7

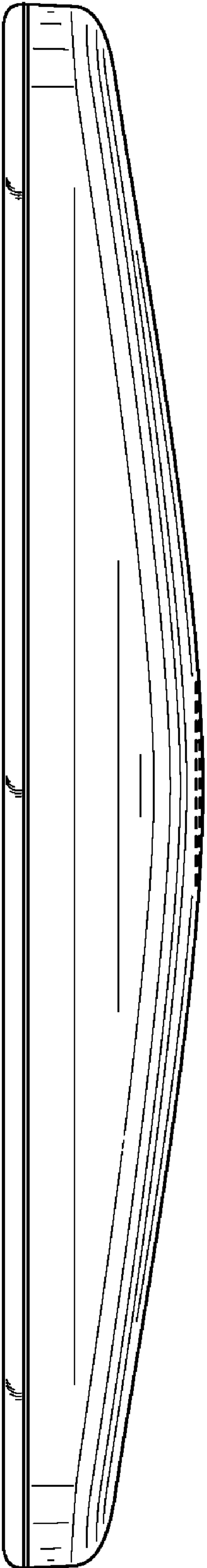

FIG. 8

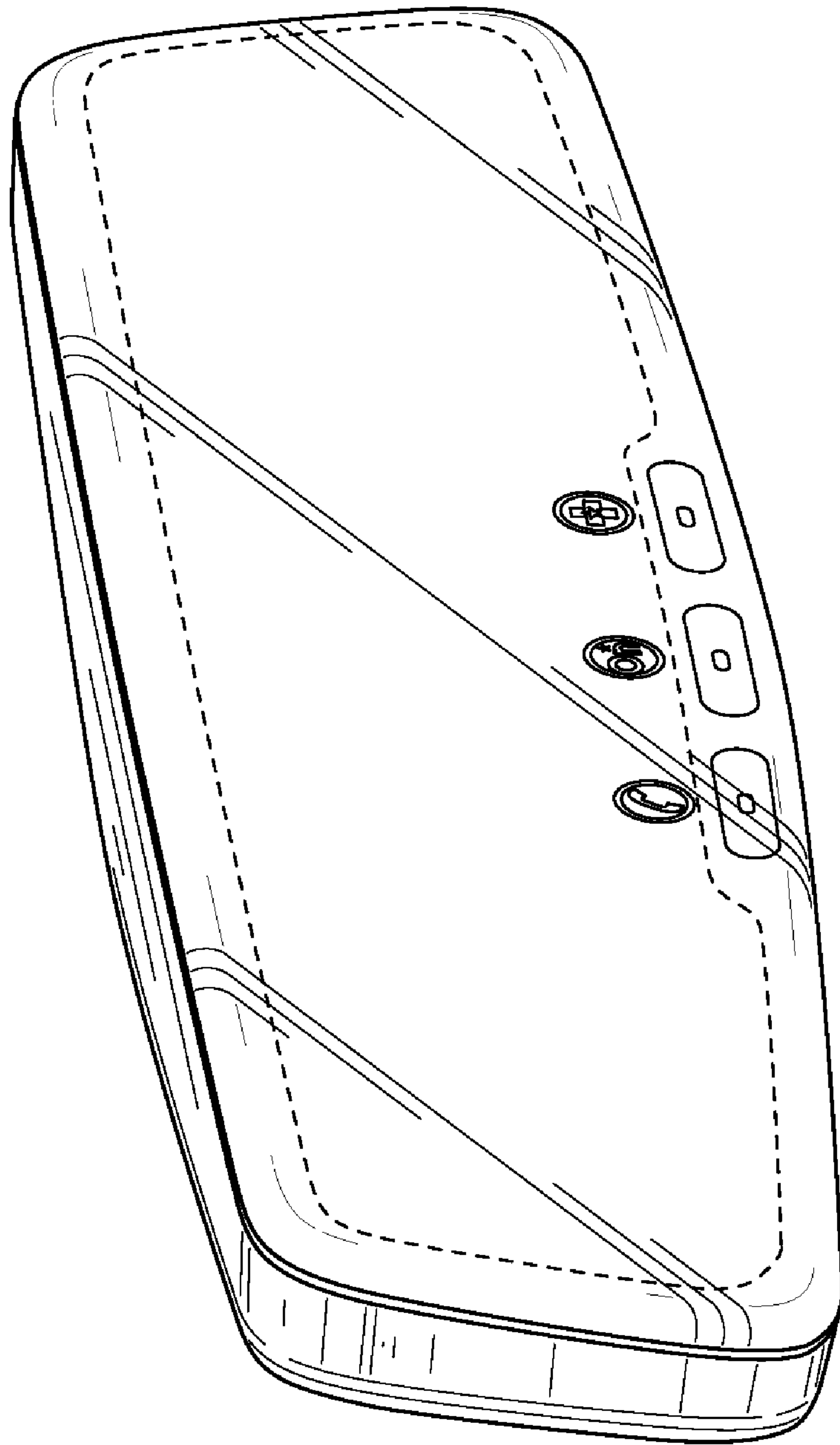

FIG. 9

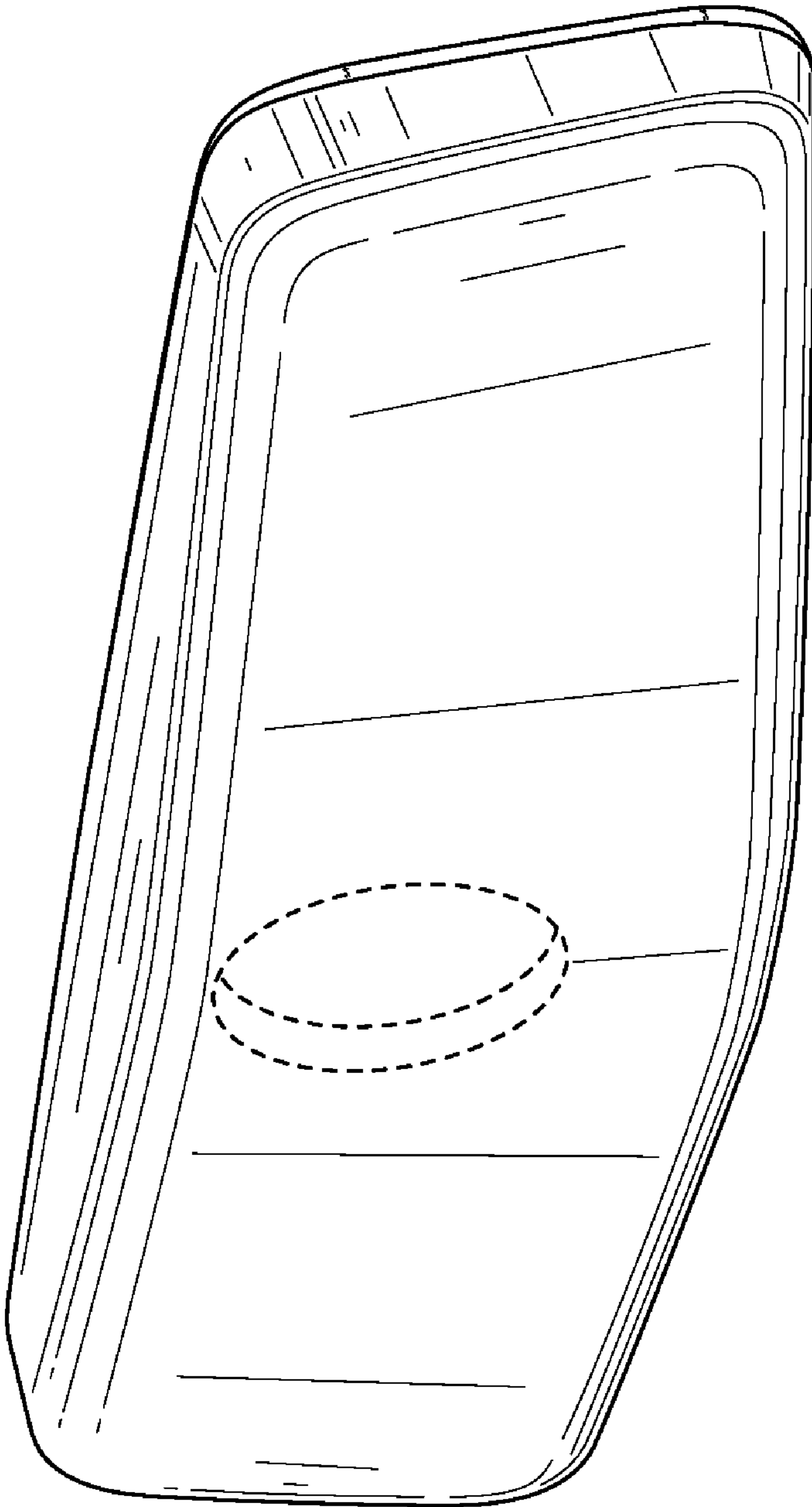

FIG. 10

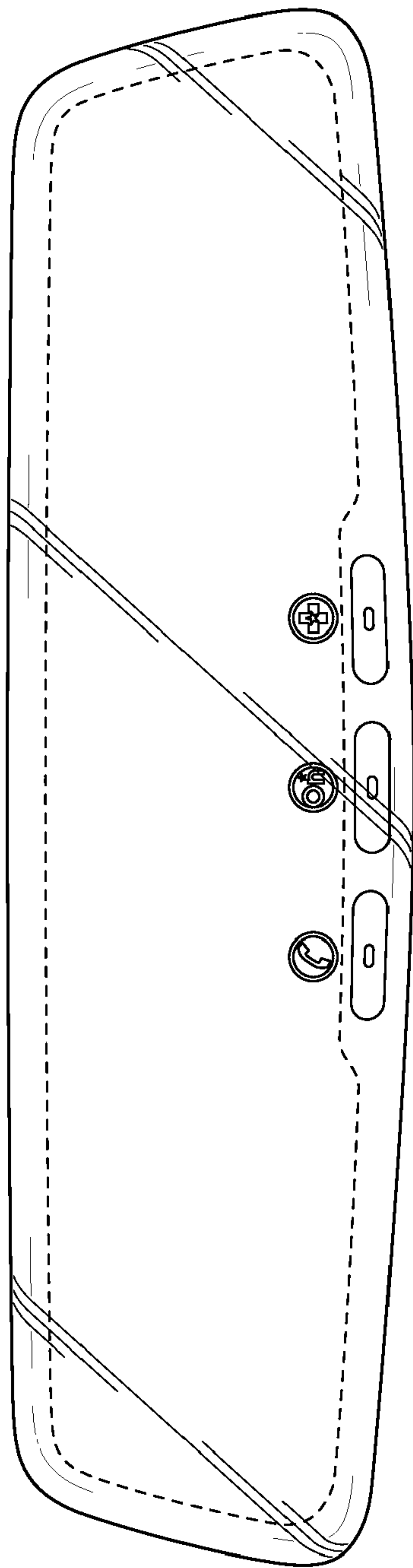

FIG. 11

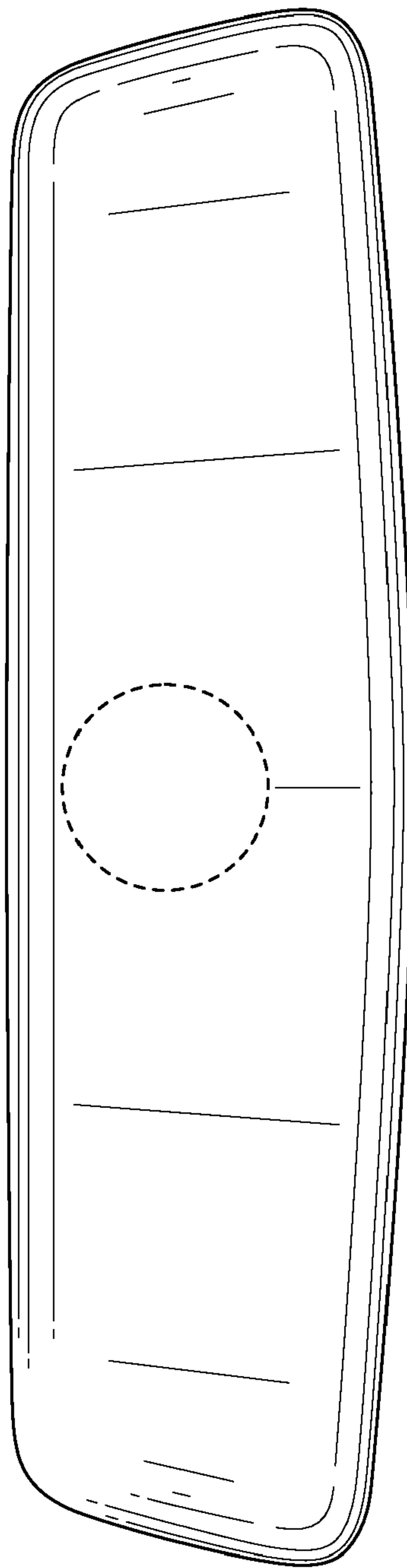

FIG. 12

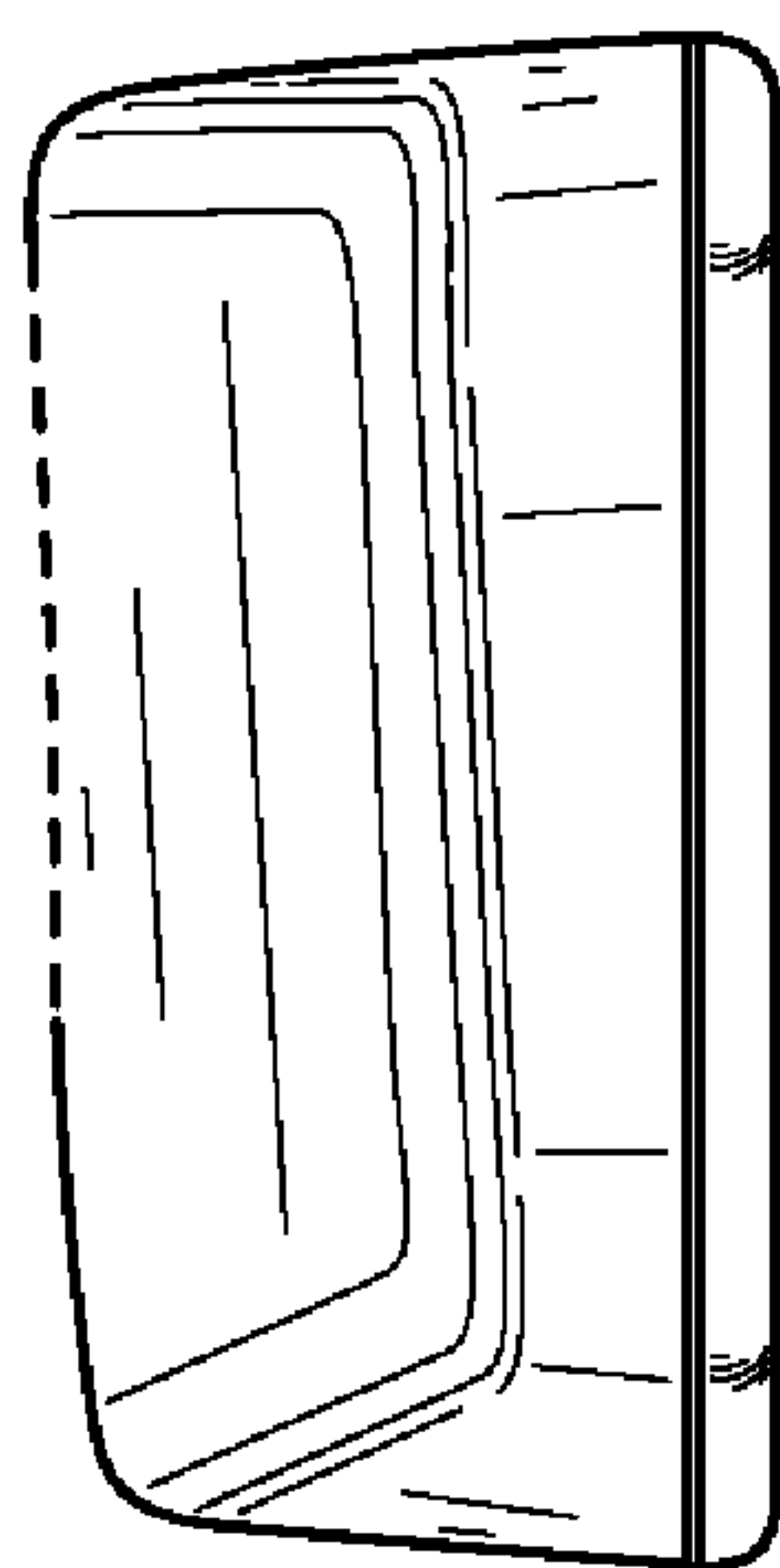

FIG. 13

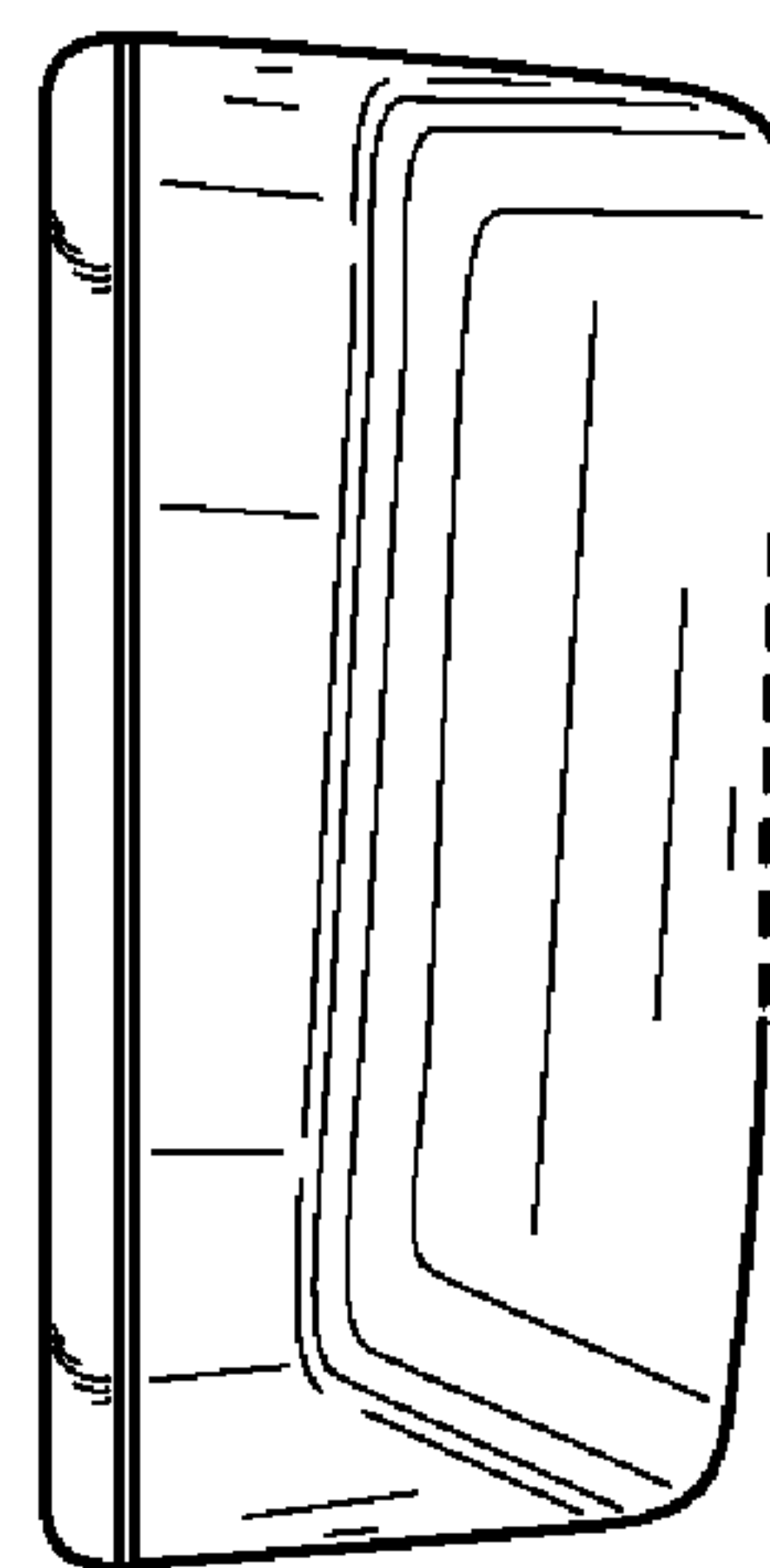

FIG. 14

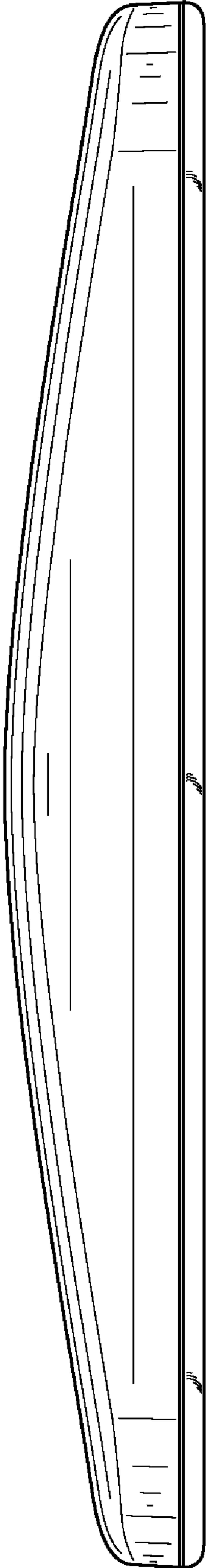

FIG. 15

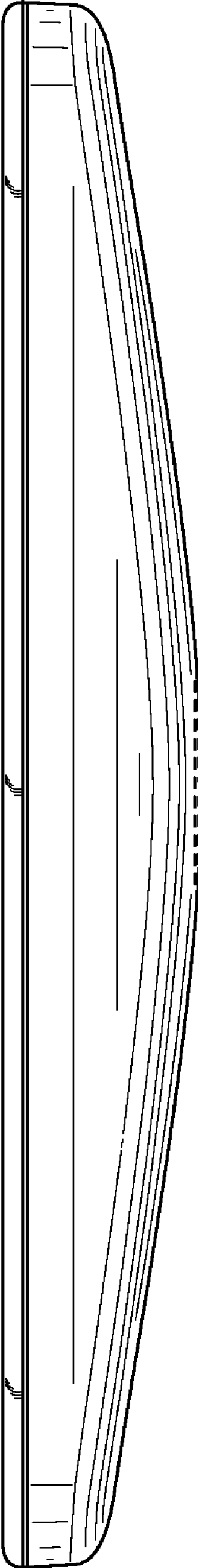

FIG. 16

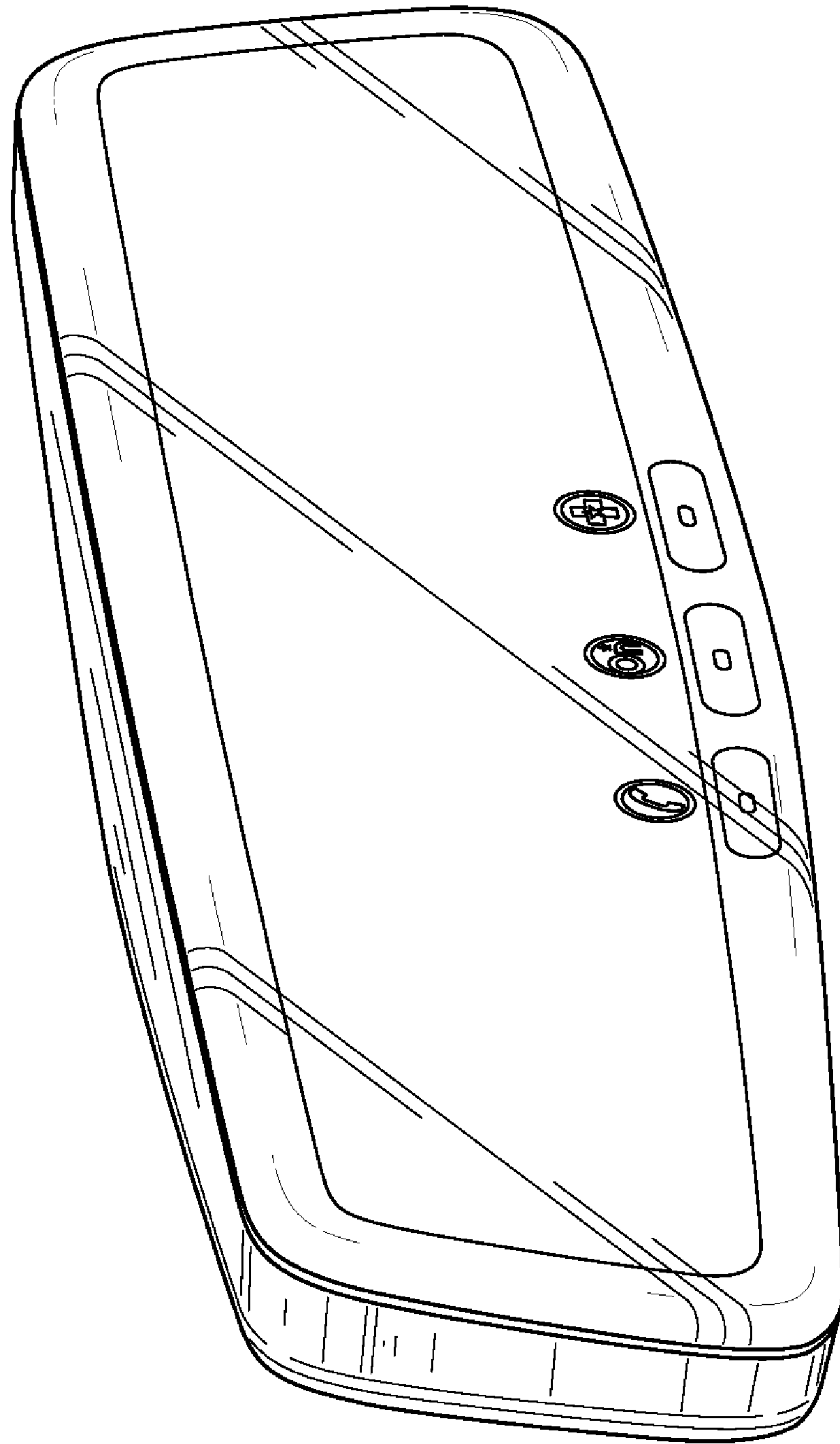

FIG. 17

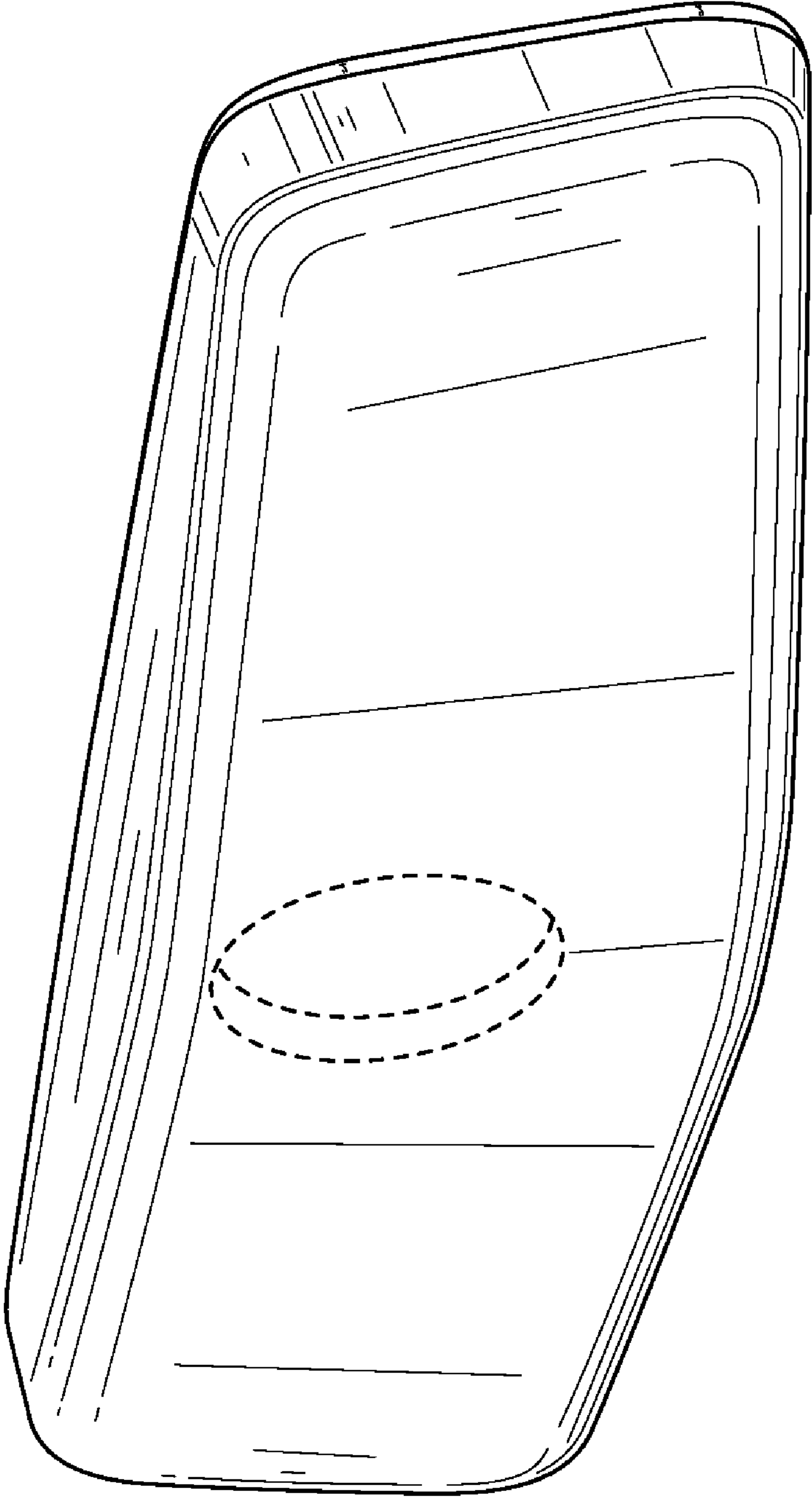

FIG. 18

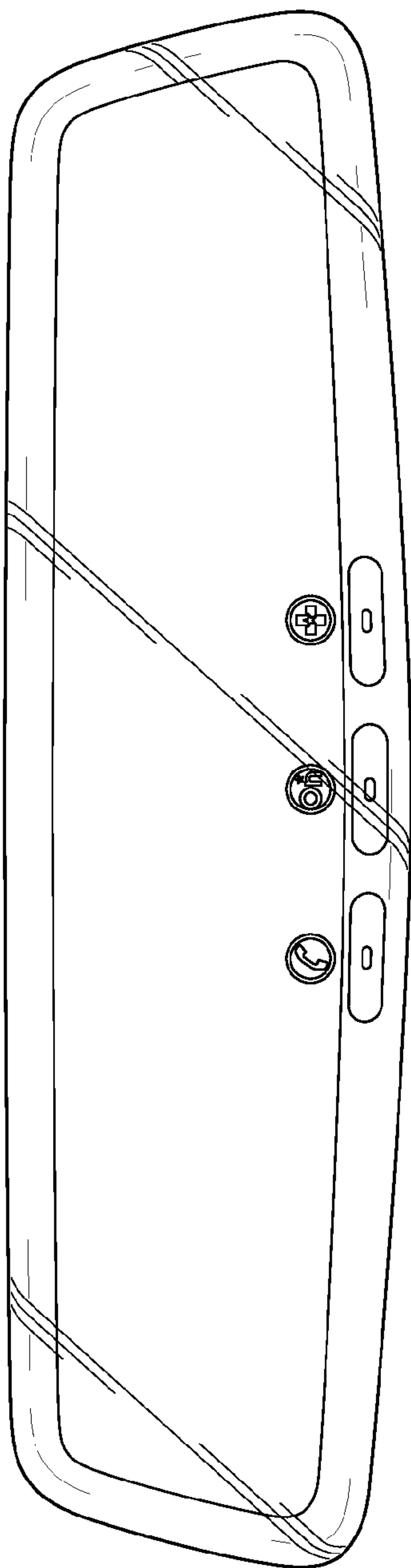

FIG. 19

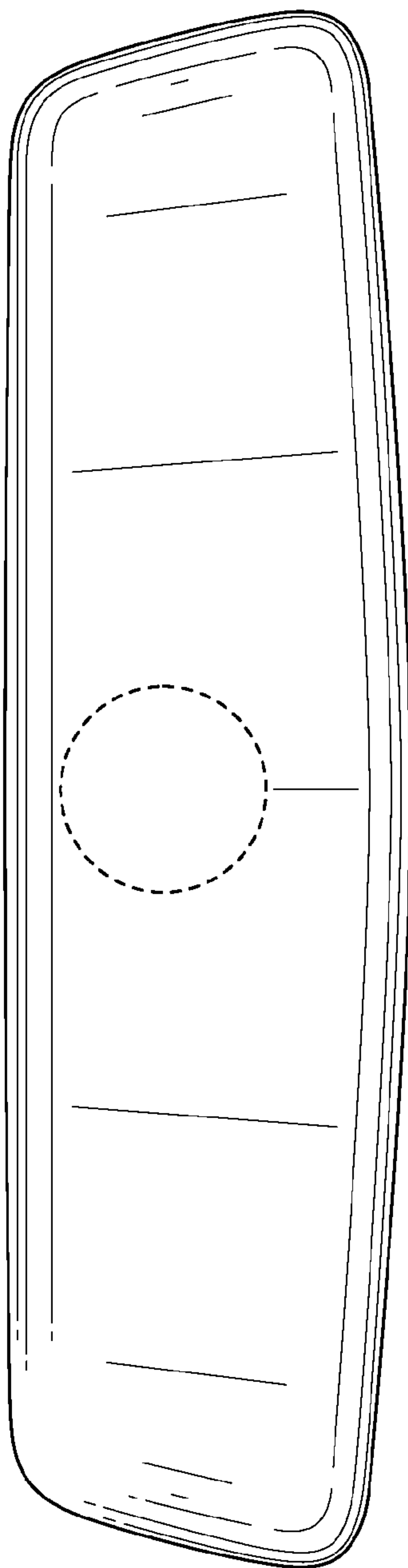

FIG. 20

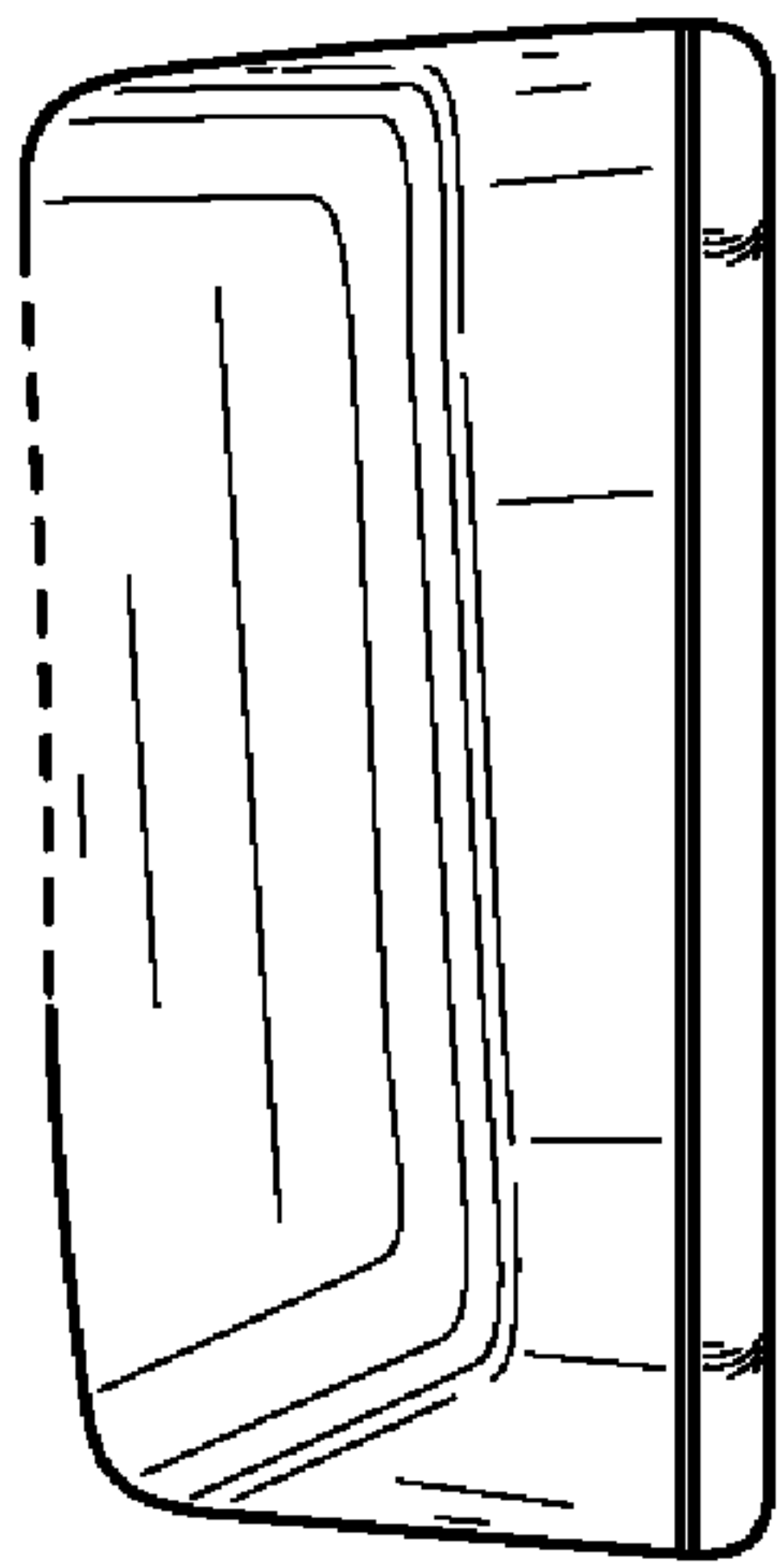

FIG. 21

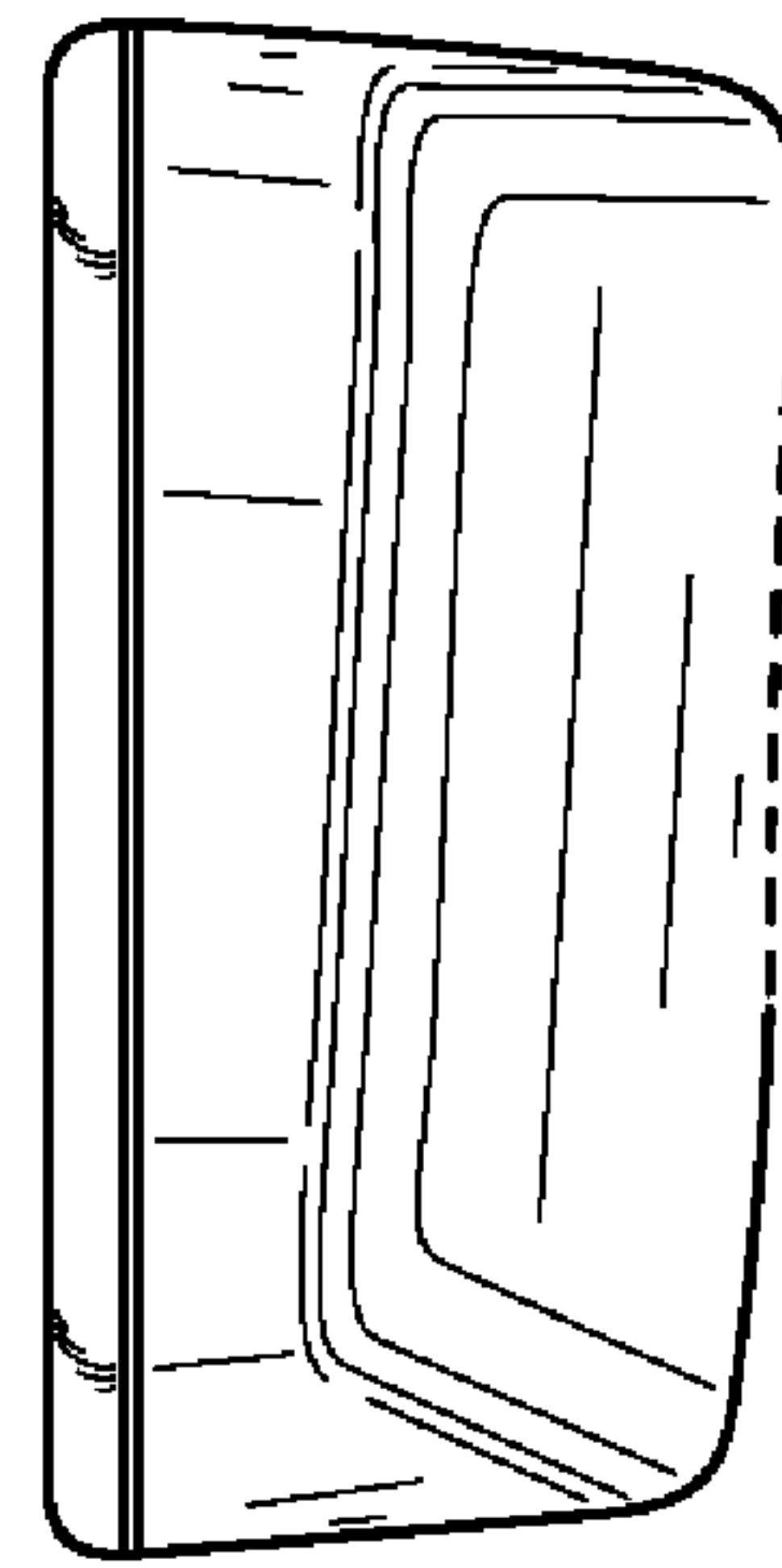

FIG. 22

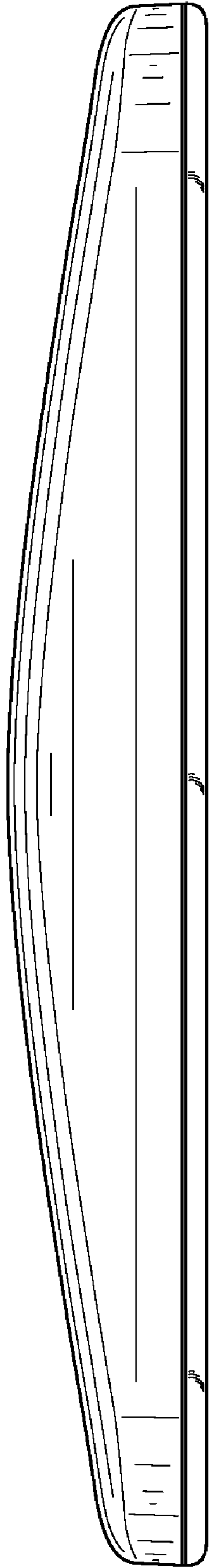

FIG. 23

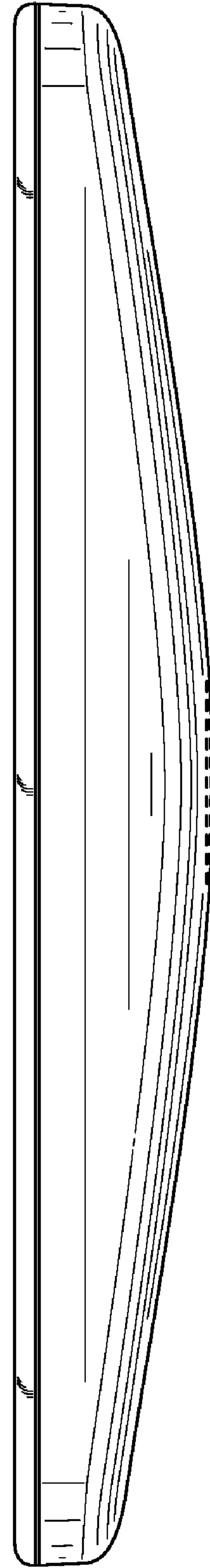

FIG. 24

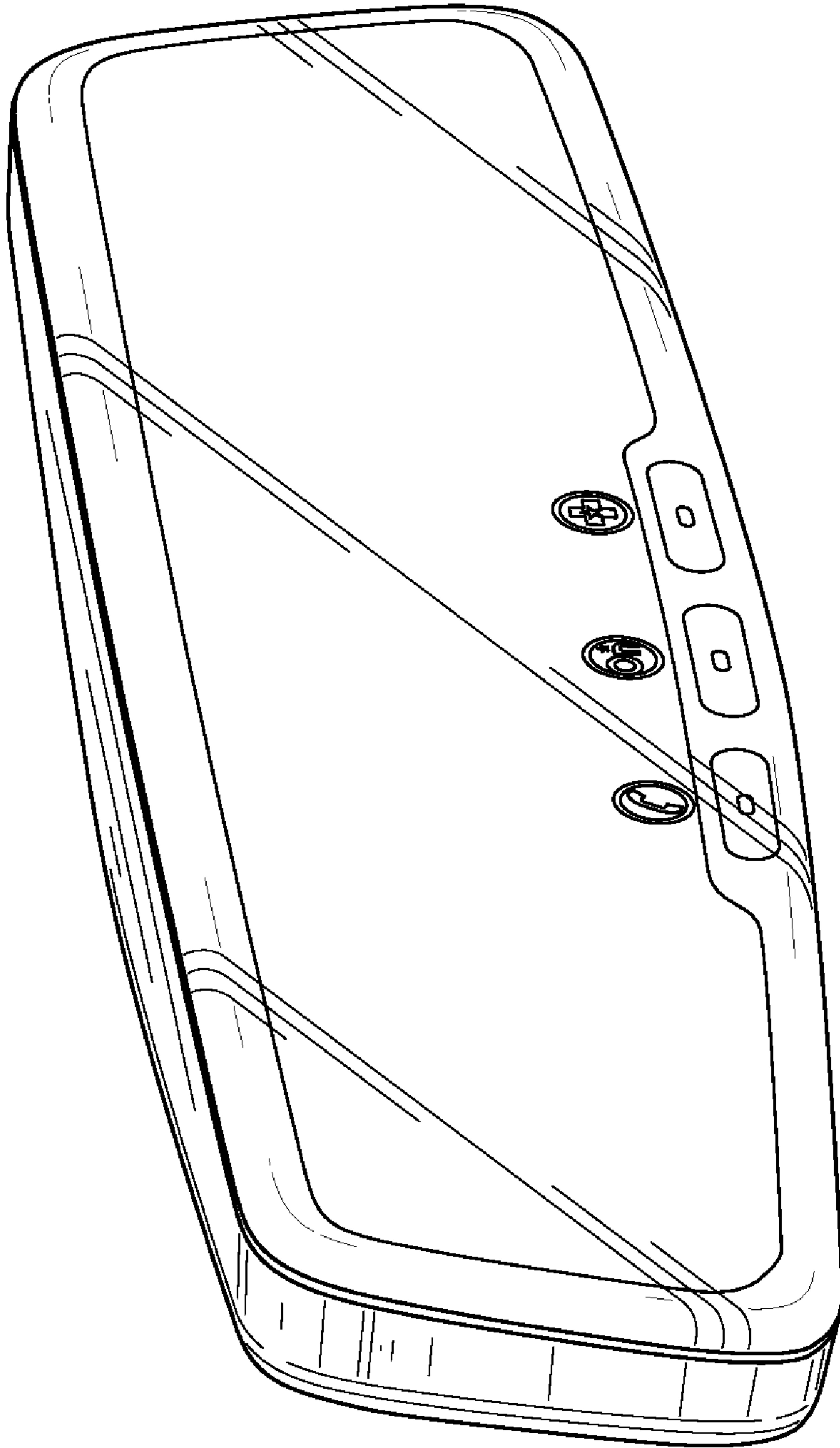

FIG. 25

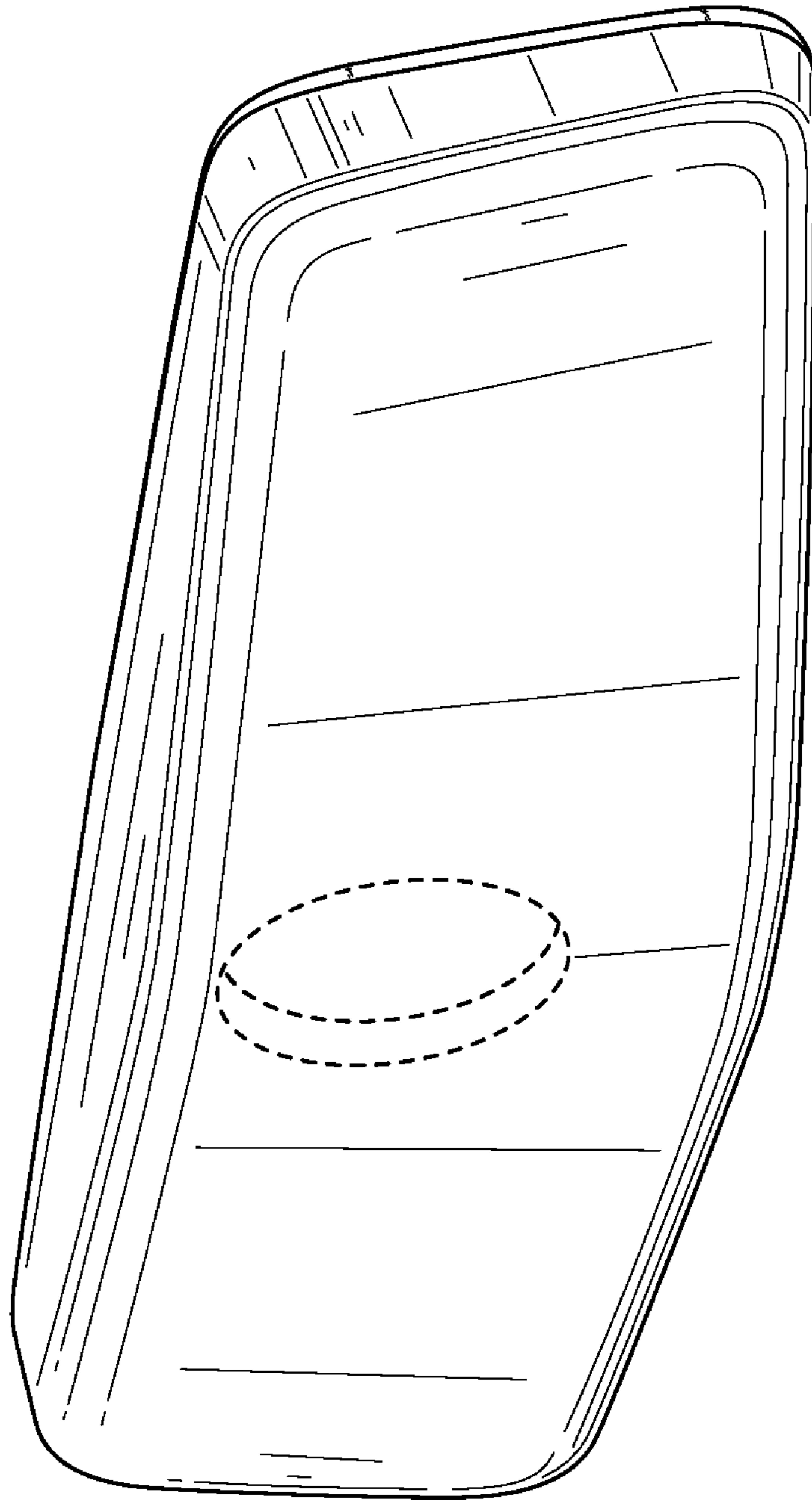

FIG. 26

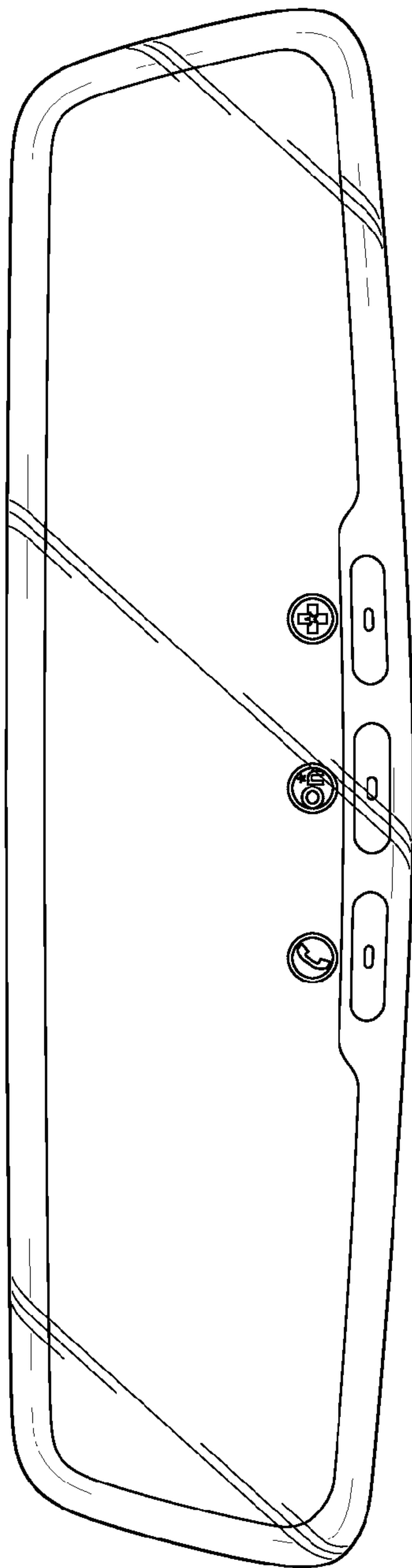

FIG. 27

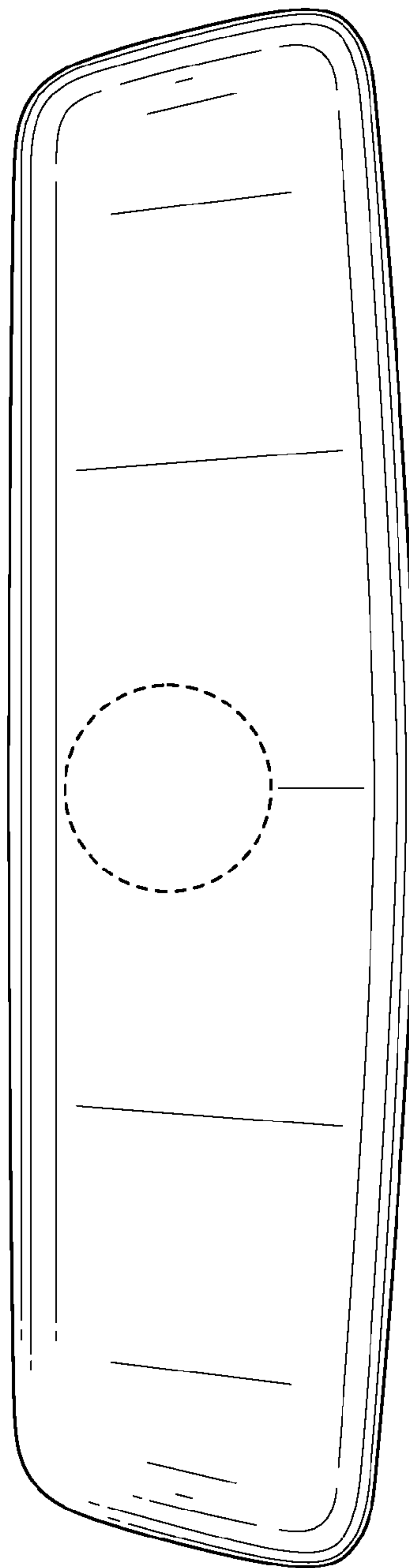

FIG. 28

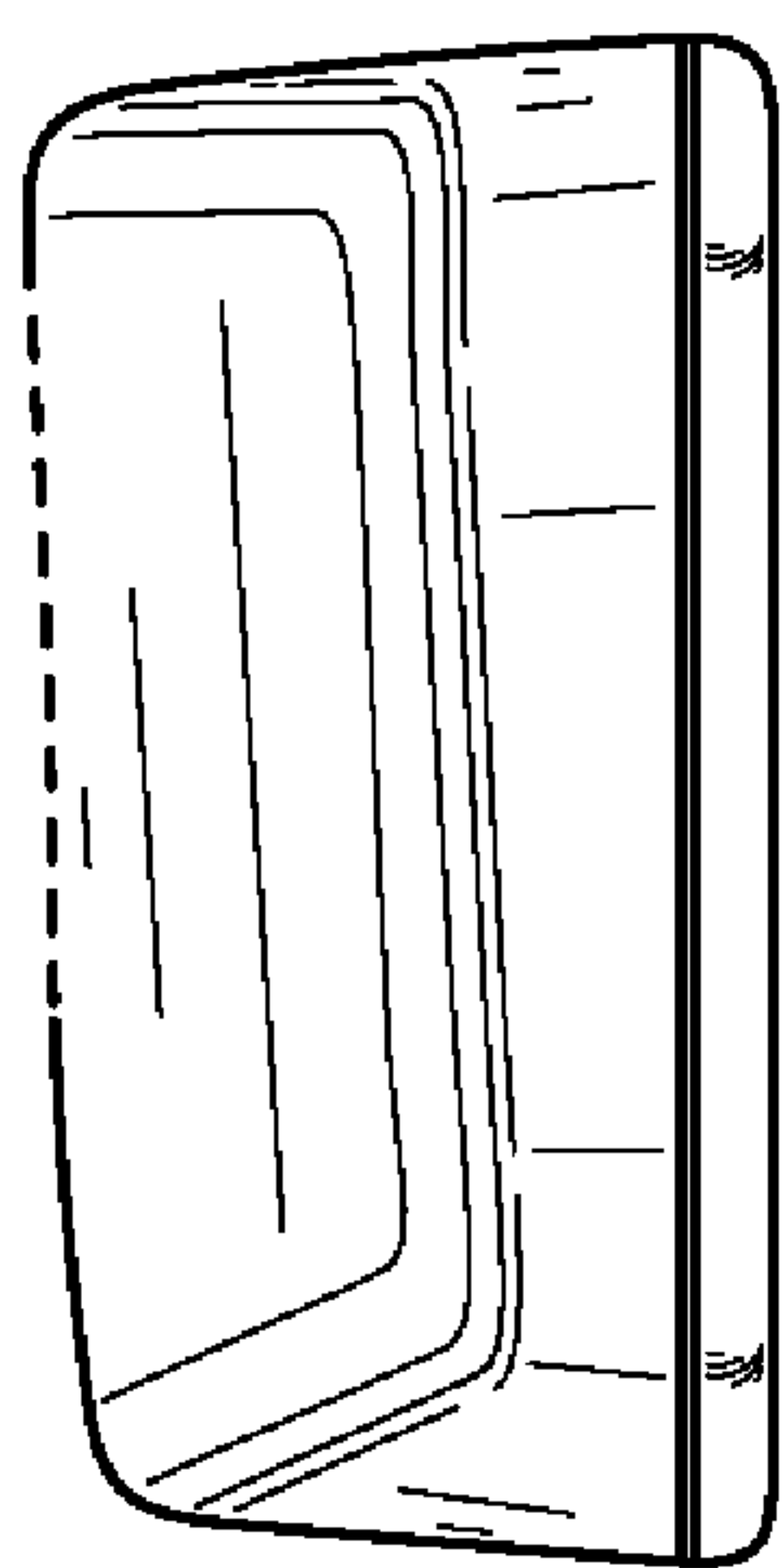

FIG. 29

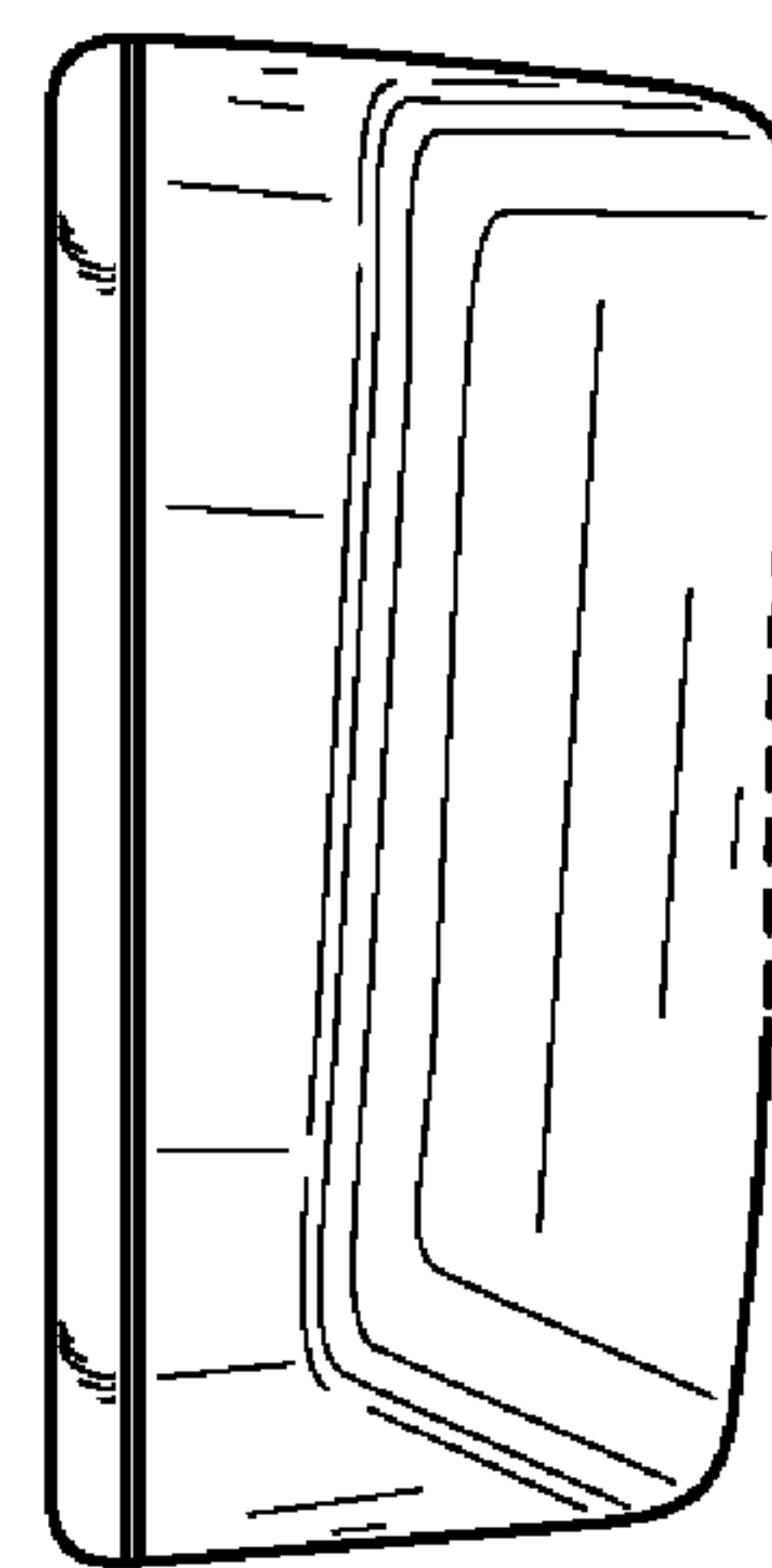

FIG. 30

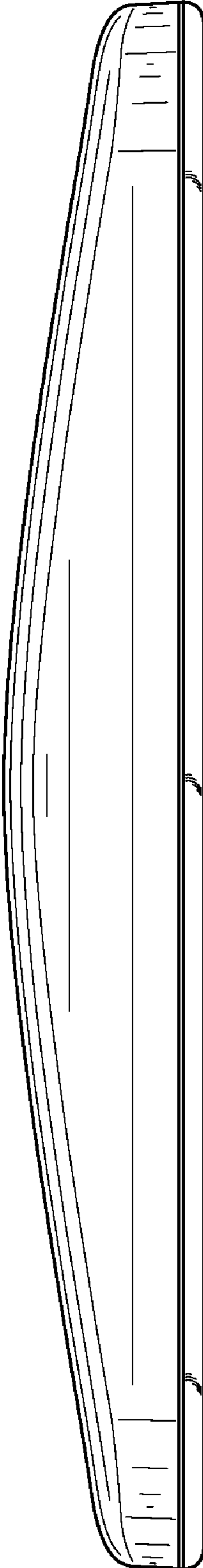

FIG. 31

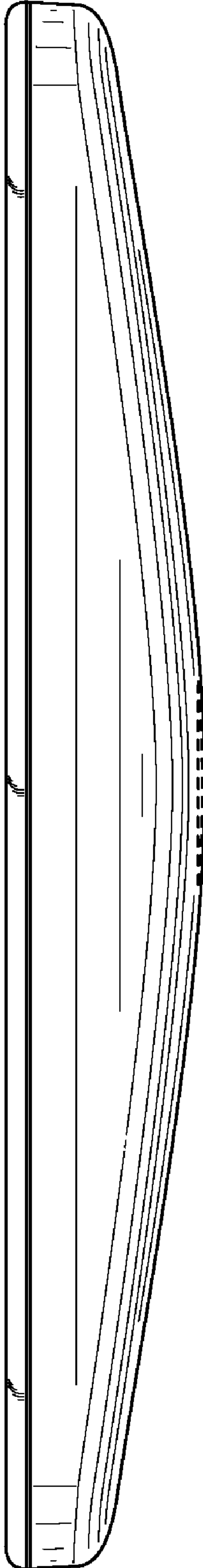

FIG. 32