



US00D638656S

(12) **United States Design Patent**  
**Brinckerhoff et al.**

(10) **Patent No.:** **US D638,656 S**

(45) **Date of Patent:** **\*\* May 31, 2011**

(54) **STICK BLENDER**

(75) Inventors: **Amy Tinnell Brinckerhoff**, Newton, MA (US); **Andrea Stavrinou**, Brighton, MA (US); **David M Audette**, Webster, MA (US)

(73) Assignee: **Euro-Pro Operating LLC**, Newton, MA (US)

(\*\*) Term: **14 Years**

(21) Appl. No.: **29/379,275**

(22) Filed: **Nov. 17, 2010**

(51) **LOC (9) Cl.** ..... **31-00**

(52) **U.S. Cl.** ..... **D7/376**

(58) **Field of Classification Search** ..... D7/300, D7/305-311, 317-318, 372-373, 376-386, D7/397, 412-415; D24/220; 99/279-281, 99/300, 306-307, 348, 509-511; 222/105, 222/129.1-129.4, 146.1-146.2, 146.4-146.6; 241/30-37.5, 101.01-101.2, 166-169.1, 241/199.12, 285.1-285.3, 291, 292.1; 366/64-67, 366/98, 142, 197-211, 241-254, 279-292, 366/341-347

See application file for complete search history.

(56) **References Cited**

**U.S. PATENT DOCUMENTS**

D271,176 S	11/1983	Zimnowicz	
D308,001 S *	5/1990	Ricard	D7/376
D345,076 S *	3/1994	Saltet	D7/376
D358,293 S *	5/1995	Sebastia	D7/376
D361,241 S *	8/1995	Littmann	D7/376
D383,938 S	9/1997	Littmann	

D392,504 S *	3/1998	Lallemand	D7/376
D398,809 S	9/1998	Henderson	
6,186,656 B1	2/2001	Penaranda et al.	
D447,380 S *	9/2001	Feil	D7/376
D456,206 S *	4/2002	Feil	D7/376
6,398,403 B1	6/2002	Rebordosa et al.	
D485,729 S *	1/2004	Patton et al.	D7/379
D510,837 S *	10/2005	Lloyd et al.	D7/376
D533,022 S *	12/2006	Piret	D7/379
D534,032 S *	12/2006	Lloyd	D7/380
7,172,334 B2	2/2007	Chiappetta	
D614,438 S *	4/2010	Fukasawa	D7/376
D623,009 S *	9/2010	Bodum	D7/376

\* cited by examiner

*Primary Examiner* — Ricky Pham

(74) *Attorney, Agent, or Firm* — Wolf, Greenfield & Sacks, P.C.

(57) **CLAIM**

The ornamental design of a stick blender, substantially as shown and described.

**DESCRIPTION**

FIG. 1 is a perspective view of a stick blender in accordance with the present design;

FIG. 2 is a front view thereof;

FIG. 3 is a rear view thereof; and

FIG. 4 is a left side view thereof;

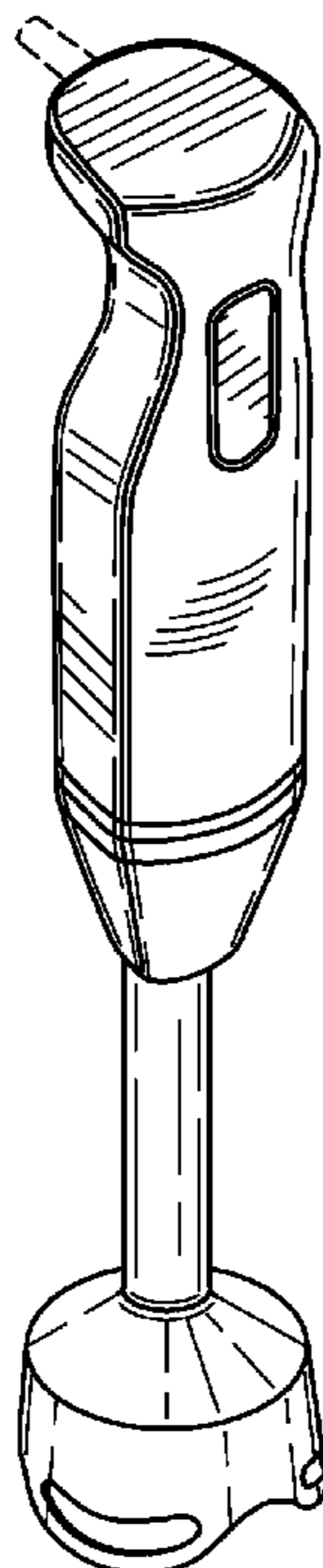
FIG. 5 is a right side view thereof;

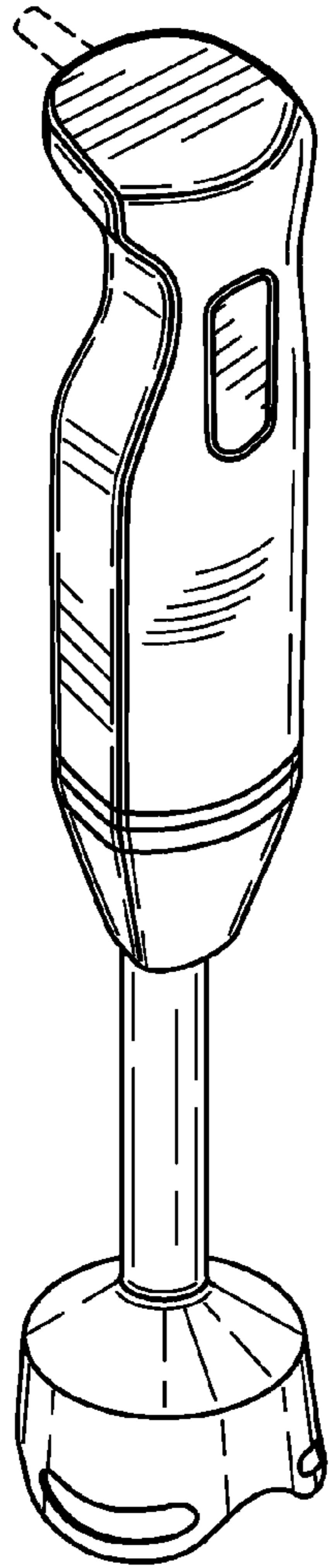
FIG. 6 is a top plan view thereof; and,

FIG. 7 is a bottom plan view thereof.

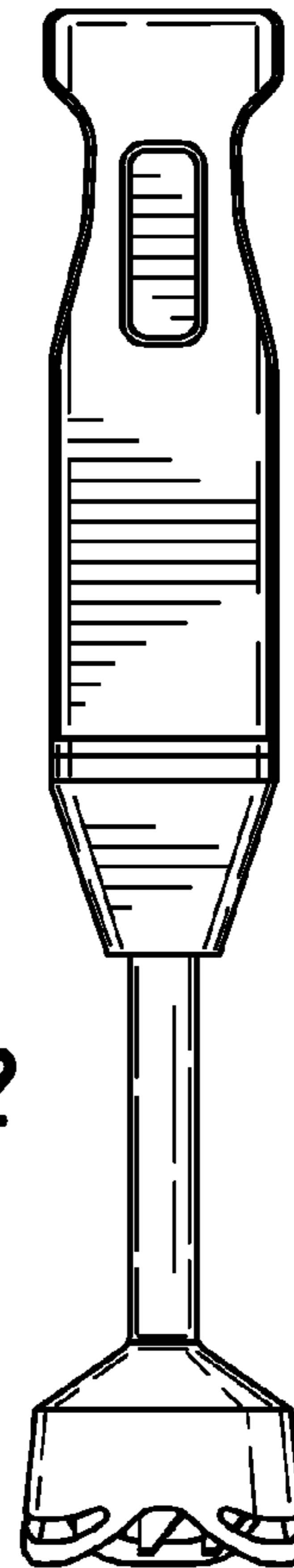
The broken lines showing power supply cord and blades are for illustrative purposes only and form no part of the claimed design.

**1 Claim, 2 Drawing Sheets**

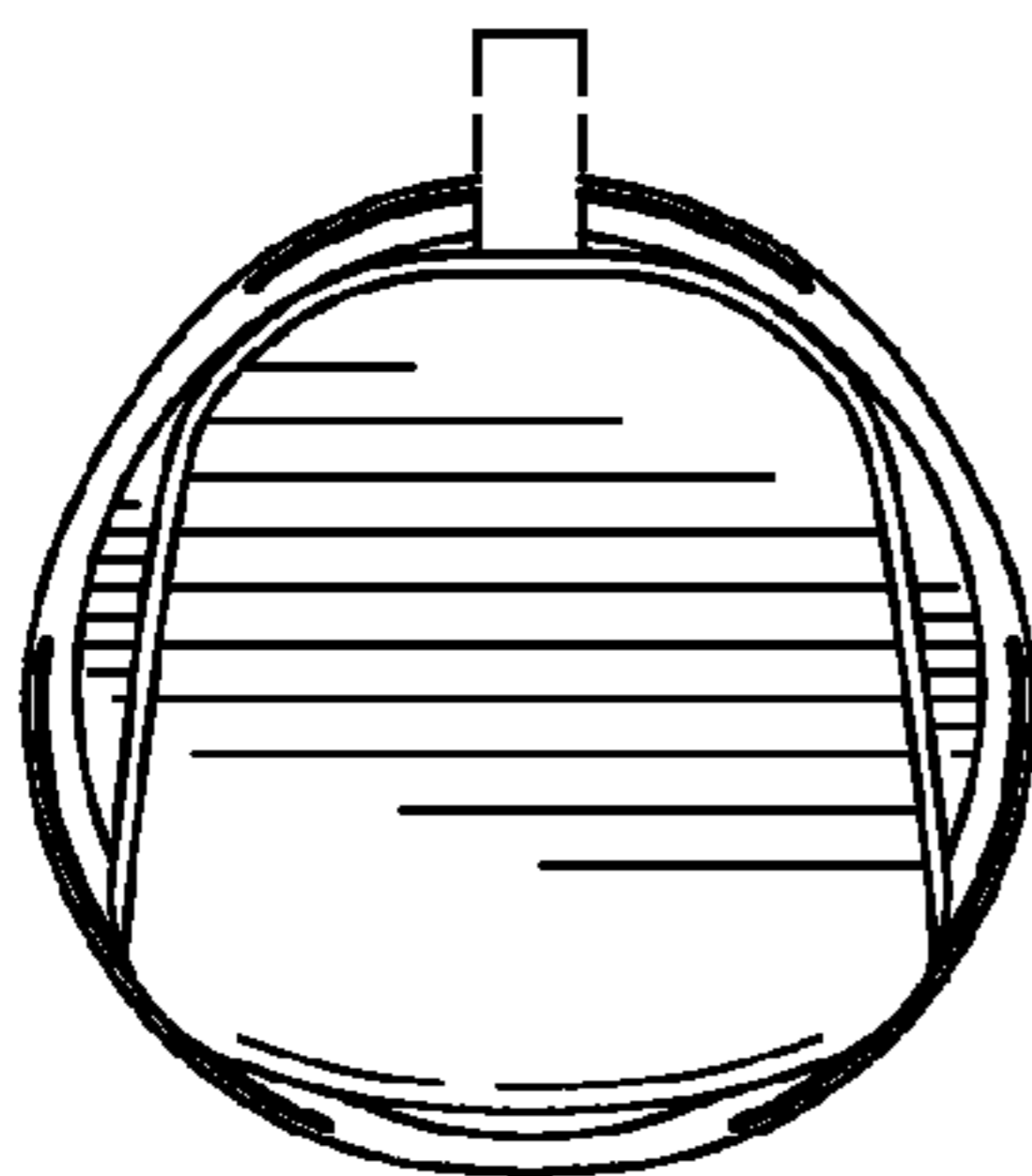




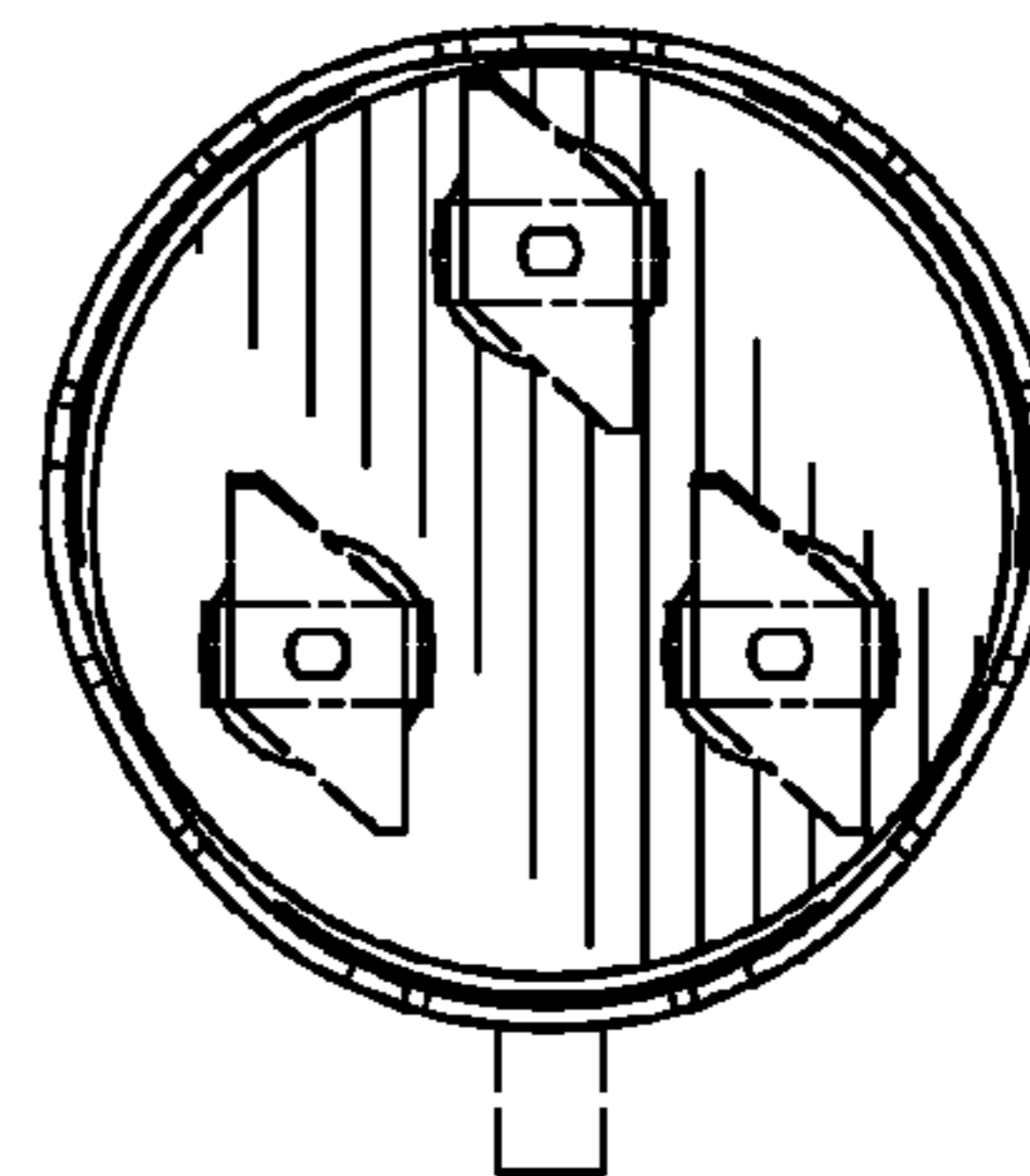
**FIG. 1**



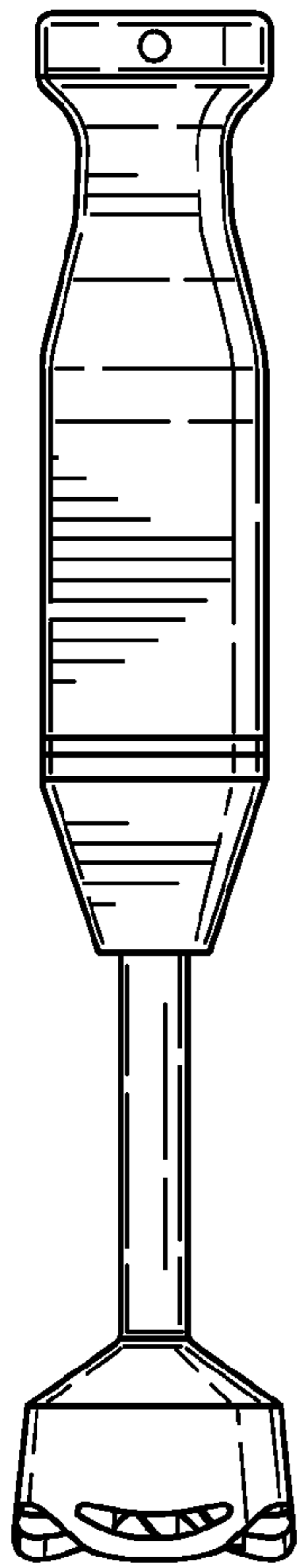
**FIG. 2**



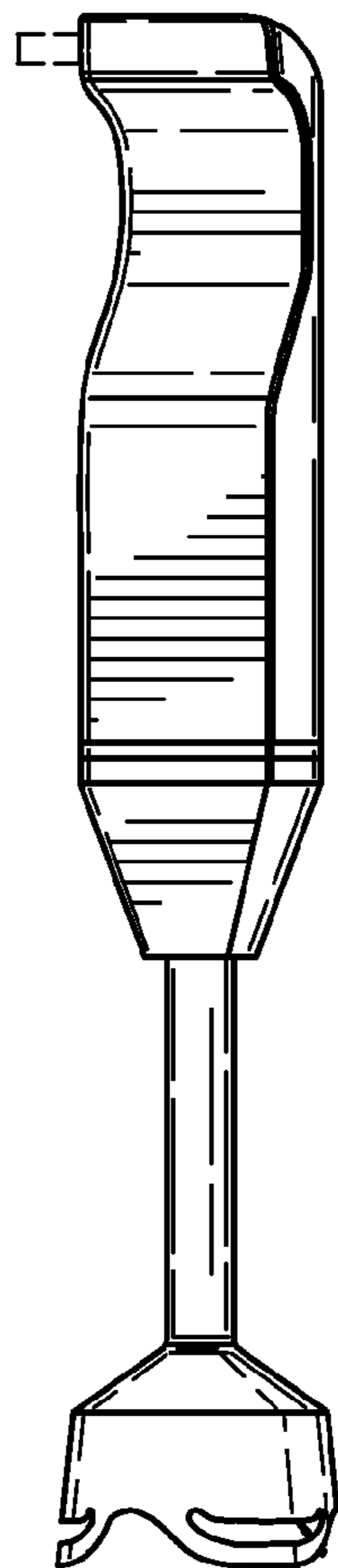
**FIG. 6**



**FIG. 7**



**FIG. 3**



**FIG. 4**

**FIG. 5**

