



US00D638066S

(12) **United States Design Patent**
Myers et al.

(10) **Patent No.:** **US D638,066 S**

(45) **Date of Patent:** **** May 17, 2011**

(54) **PORTABLE GAME PLAYER**

(75) Inventors: **Stephen Myers**, Redwood City, CA (US); **Robert Brunner**, San Francisco, CA (US); **Timothy Tan**, San Francisco, CA (US); **Kenneth Sweet**, San Francisco, CA (US); **Joe Taylor**, San Francisco, CA (US); **Steven Nersesian**, San Francisco, CA (US)

(73) Assignee: **Panasonic Corporation of North America**, Secaucus, NJ (US)

(**) Term: **14 Years**

(21) Appl. No.: **29/368,747**

(22) Filed: **Aug. 27, 2010**

(51) **LOC (9) Cl.** **21-01**

(52) **U.S. Cl.** **D21/330**

(58) **Field of Classification Search** D21/324,
D21/329, 330, 333; D14/496, 125; 273/148 B;
463/1, 2, 29-36, 45, 47; 345/156, 173, 867,
345/903; 361/679, 681, 672, 500

See application file for complete search history.

(56) **References Cited**

U.S. PATENT DOCUMENTS

4,542,903	A *	9/1985	Yokoi et al.	463/31
D378,686	S *	4/1997	Proctor et al.	D19/60
5,847,698	A *	12/1998	Reavey et al.	345/173
5,988,902	A *	11/1999	Holehan	400/479.1
D441,802	S *	5/2001	Lee	D21/330
6,307,535	B1 *	10/2001	Kim et al.	345/157
6,490,351	B1 *	12/2002	Roberts	379/452
D484,918	S *	1/2004	Okada et al.	D21/330
6,850,407	B2 *	2/2005	Tanimoto et al.	361/679.27
D515,633	S *	2/2006	Avery	D21/330
D532,051	S *	11/2006	Sugino et al.	D21/330
D559,327	S *	1/2008	Luk et al.	D21/332

OTHER PUBLICATIONS

Image of two electronic devices with screen and keyboard, available before filing date of present patent application.

* cited by examiner

Primary Examiner — Prabhakar Deshmukh

(57) **CLAIM**

We claim the ornamental design for a portable game player, as shown and described.

DESCRIPTION

FIG. 1 is an upper right front perspective view of a portable game player showing our new design in a closed state; FIG. 2 is a lower left rear perspective view of a portable game player showing our new design in a closed state; FIG. 3 is a front elevational view of a portable game player showing our new design in a closed state; FIG. 4 is a rear elevational view of a portable game player showing our new design in a closed state; FIG. 5 is a left side elevational view of a portable game player showing our new design in a closed state, the right side elevational view being a mirror image thereof; FIG. 6 is a top plan view of a portable game player showing our new design in a closed state; FIG. 7 is a bottom plan view of a portable game player showing our new design in a closed state; FIG. 8 is an upper right front perspective view of a portable game player showing our new design in an opened state; FIG. 9 is a lower left rear perspective view of a portable game player showing our new design in an opened state; FIG. 10 is a front elevational view of a portable game player showing our new design in an opened state; FIG. 11 is a rear elevational view of a portable game player showing our new design in an opened state; FIG. 12 is a left side elevational view of a portable game player showing our new design in an opened state, the right side elevational view being a mirror image thereof; FIG. 13 is a top plan view of a portable game player showing our new design in an opened state; and, FIG. 14 is a bottom plan view of a portable game player showing our new design in an opened state.

1 Claim, 9 Drawing Sheets

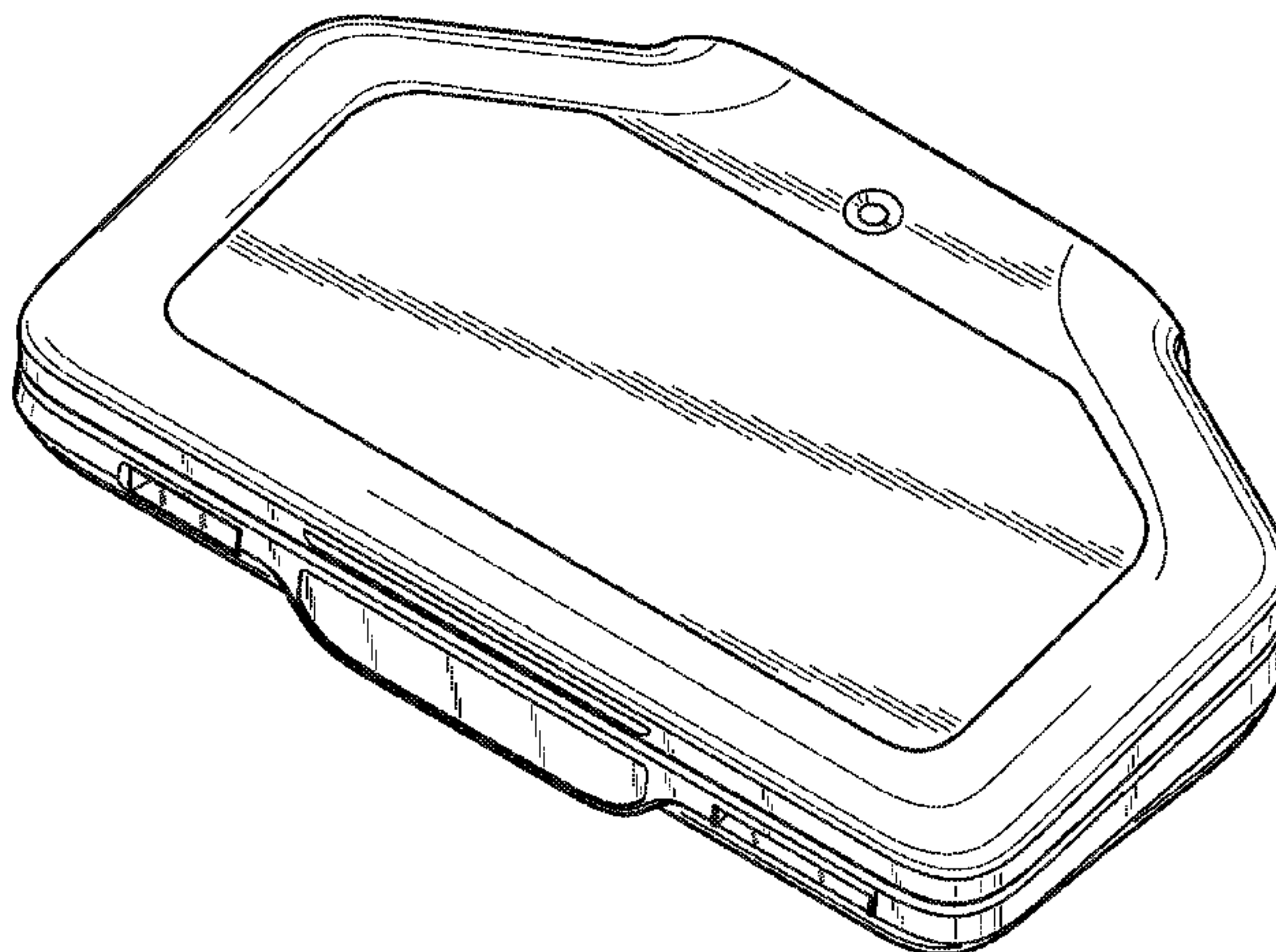

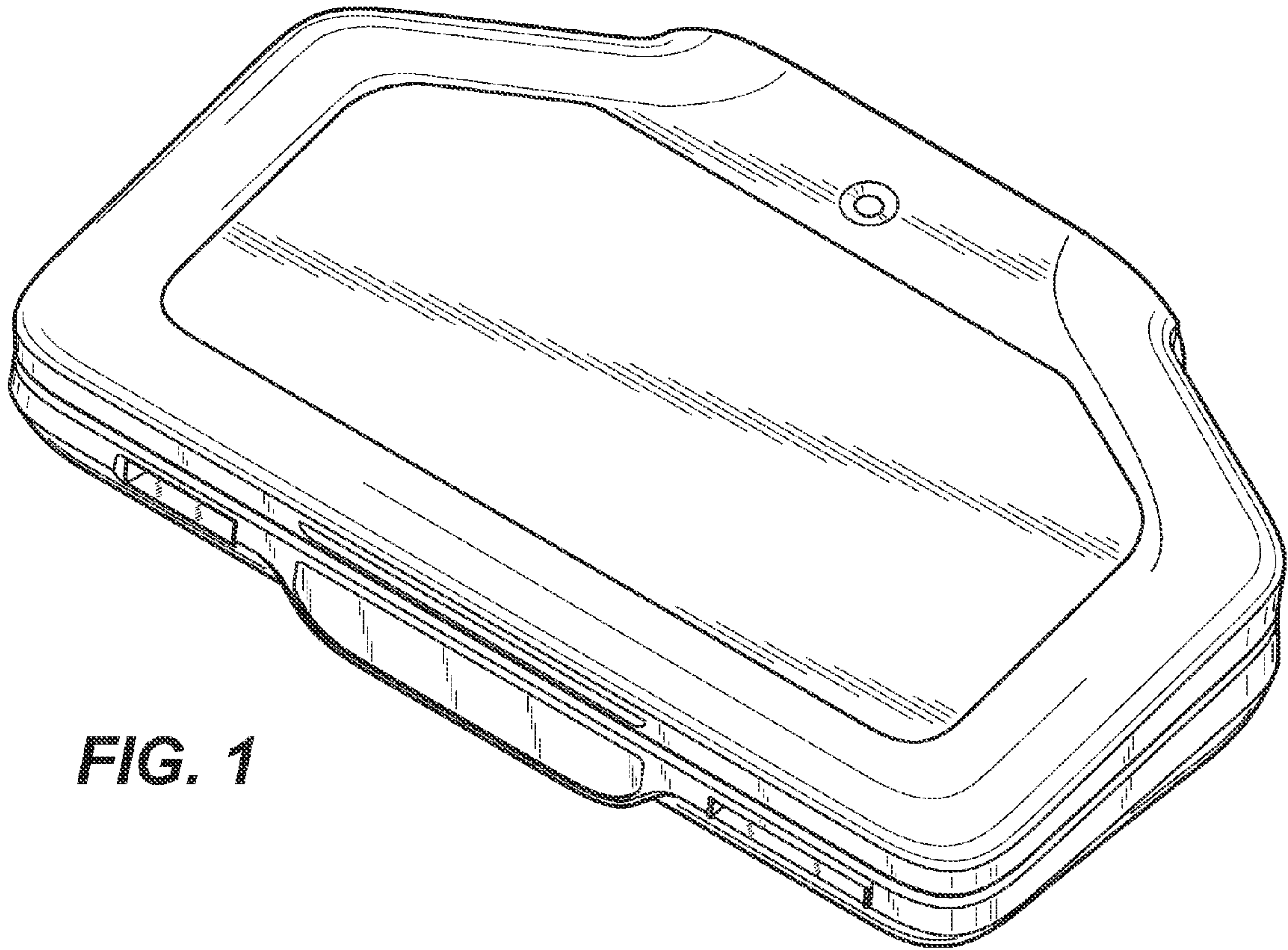

FIG. 1

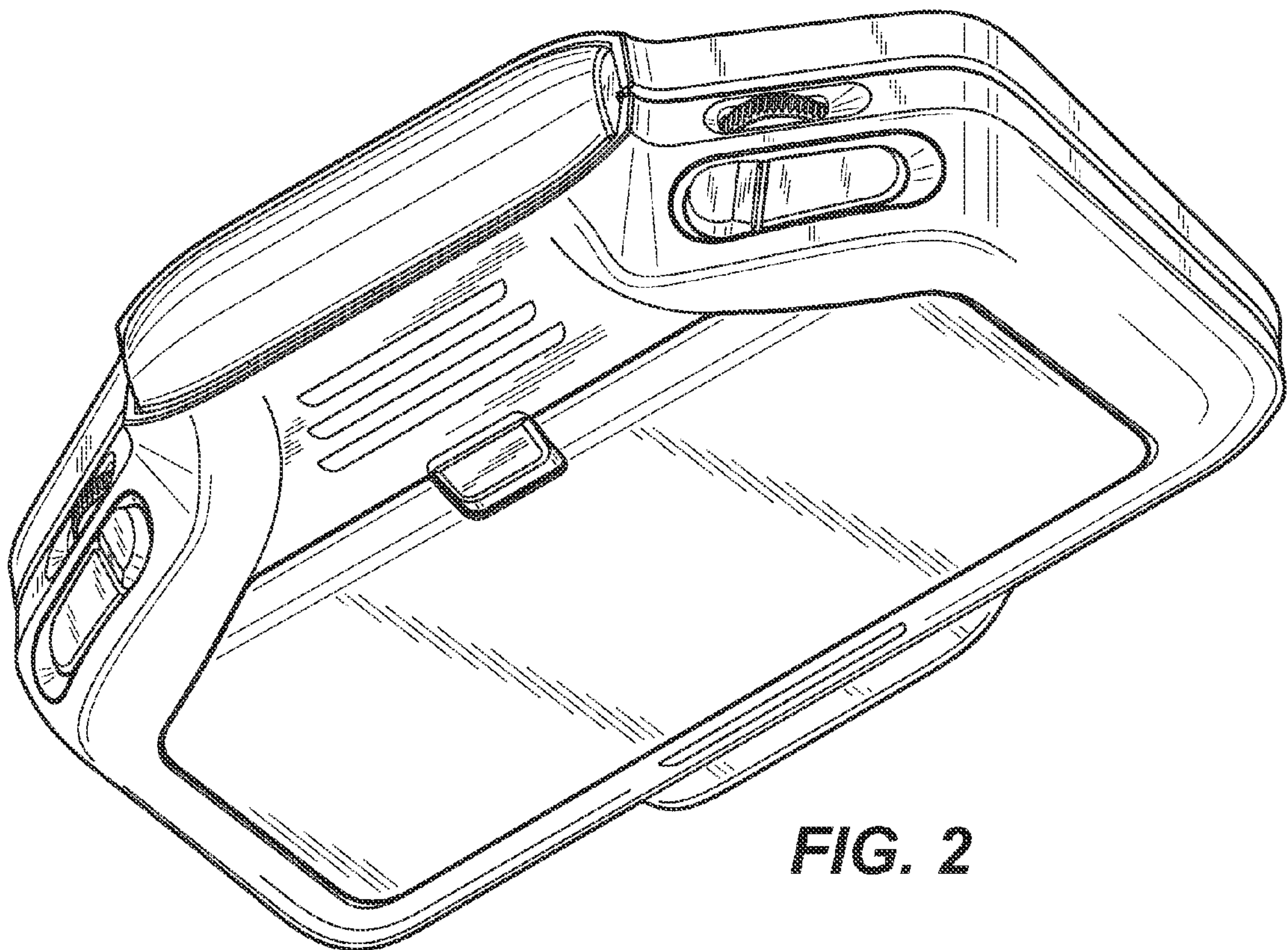

FIG. 2

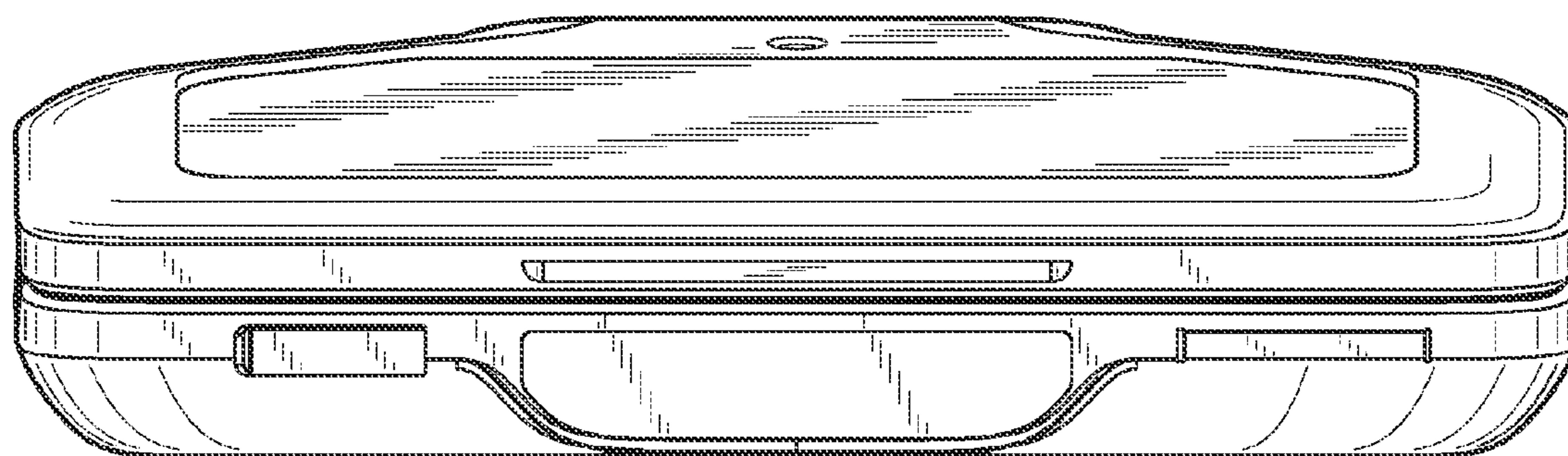

FIG. 3

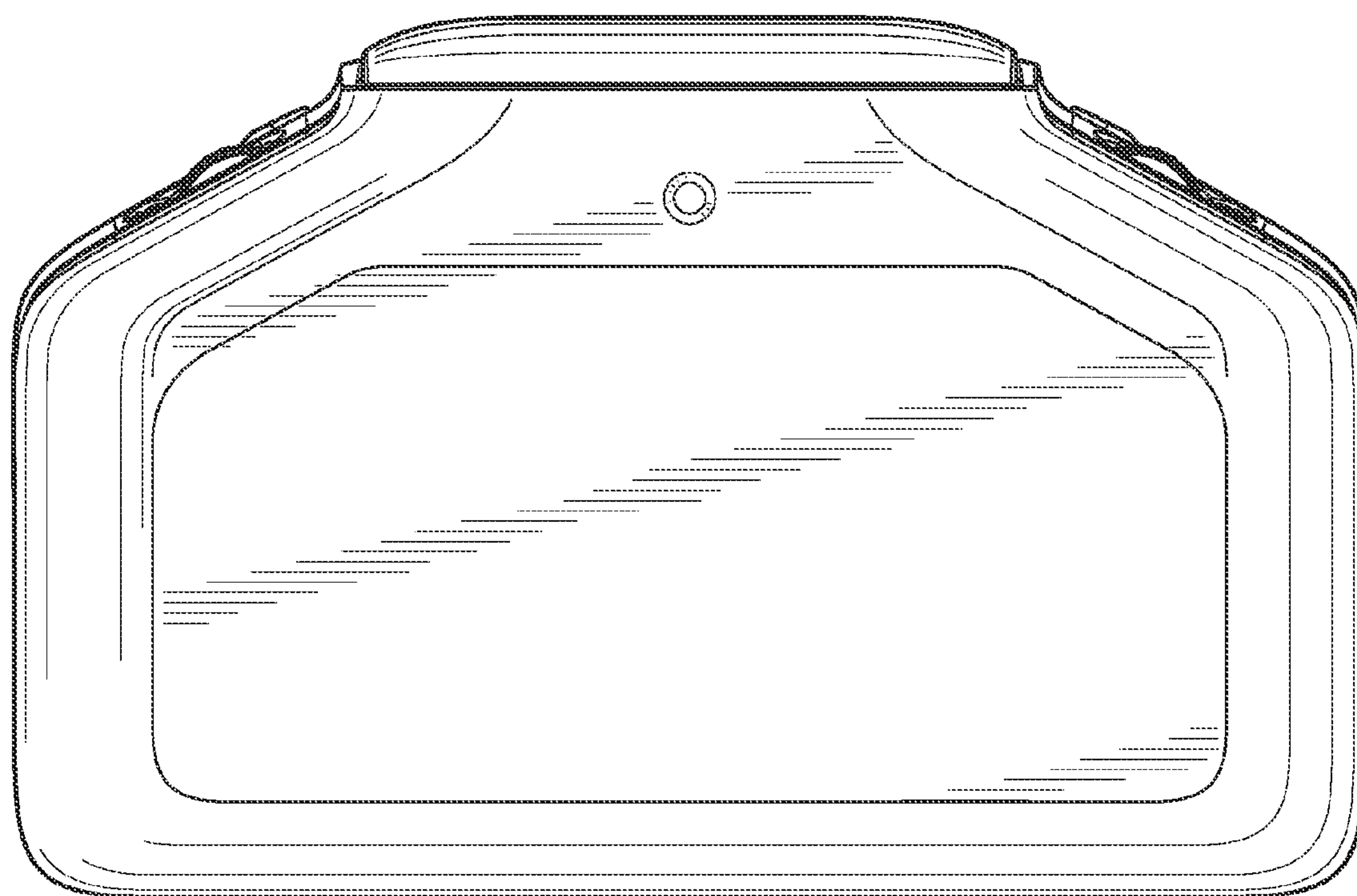

FIG. 6

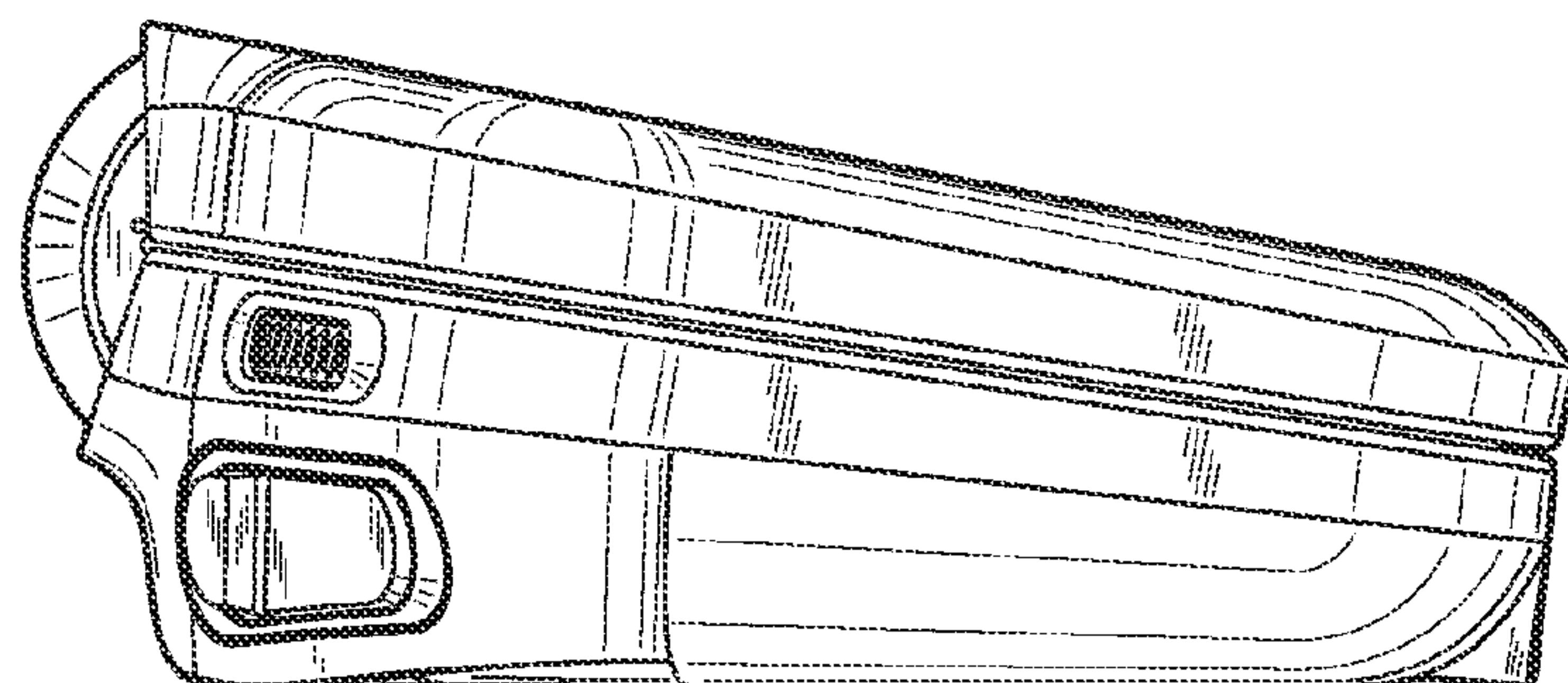

FIG. 5

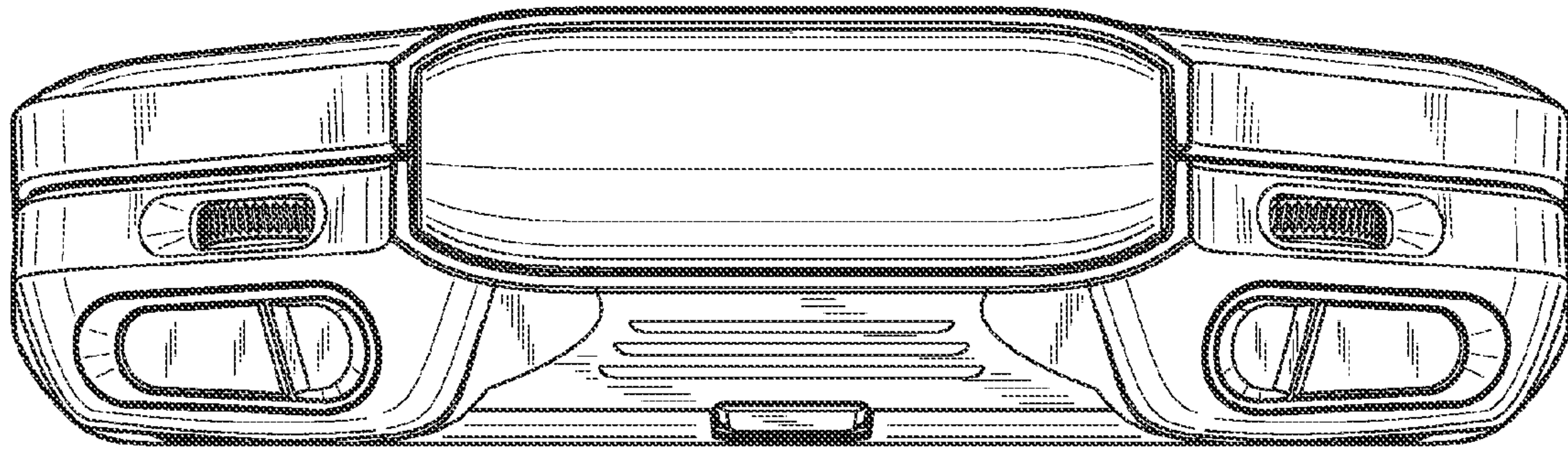

FIG. 4

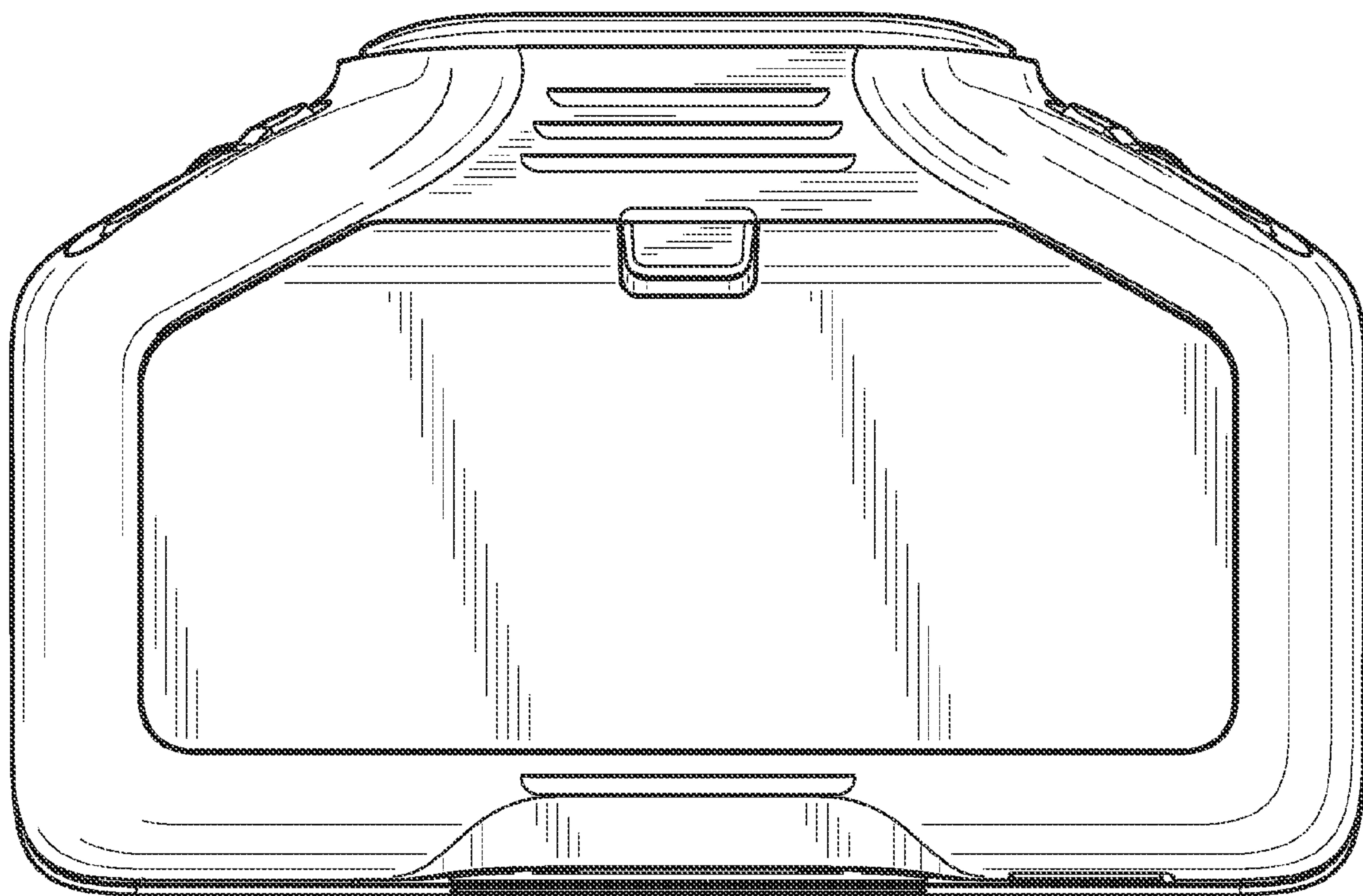

FIG. 7

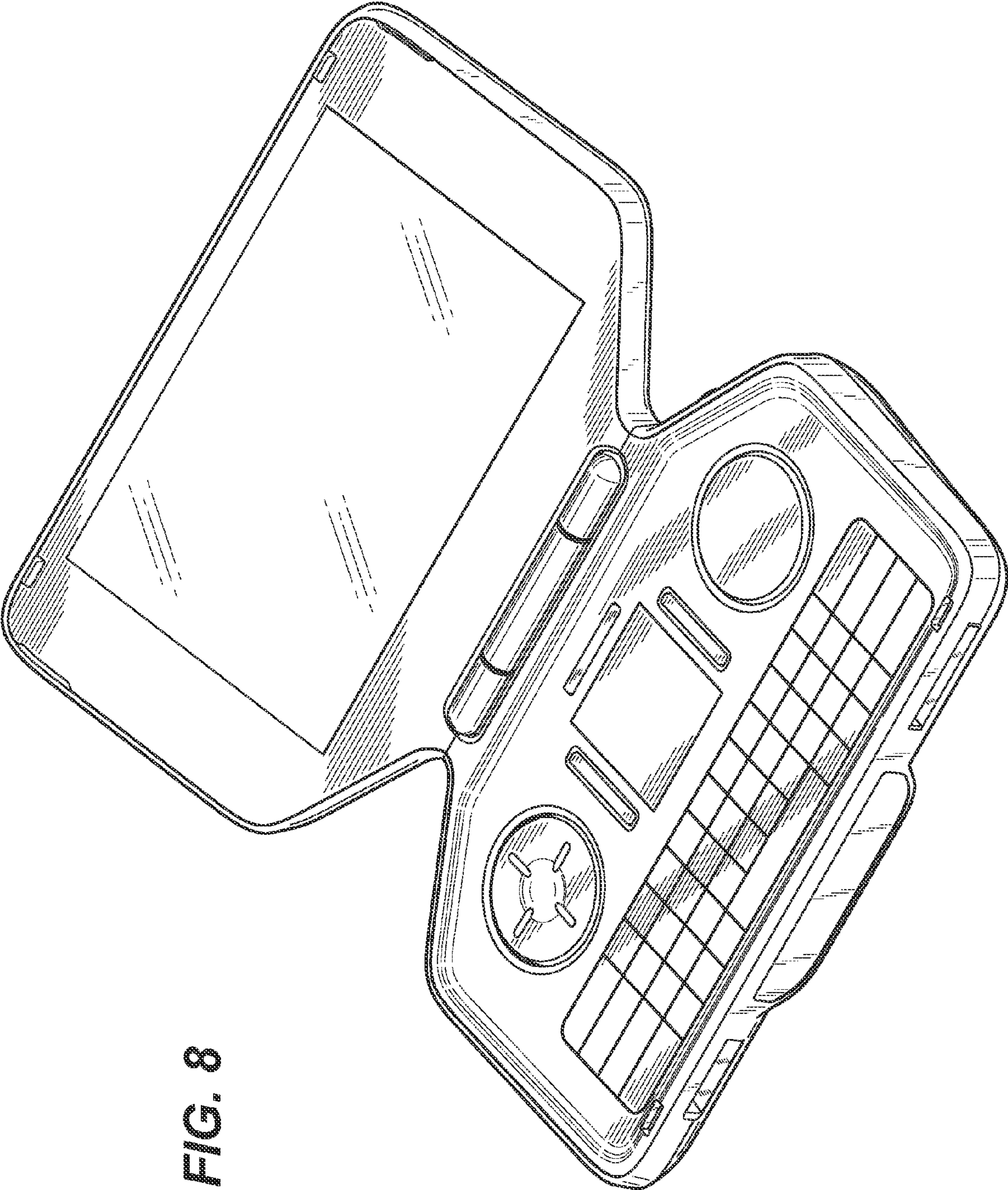
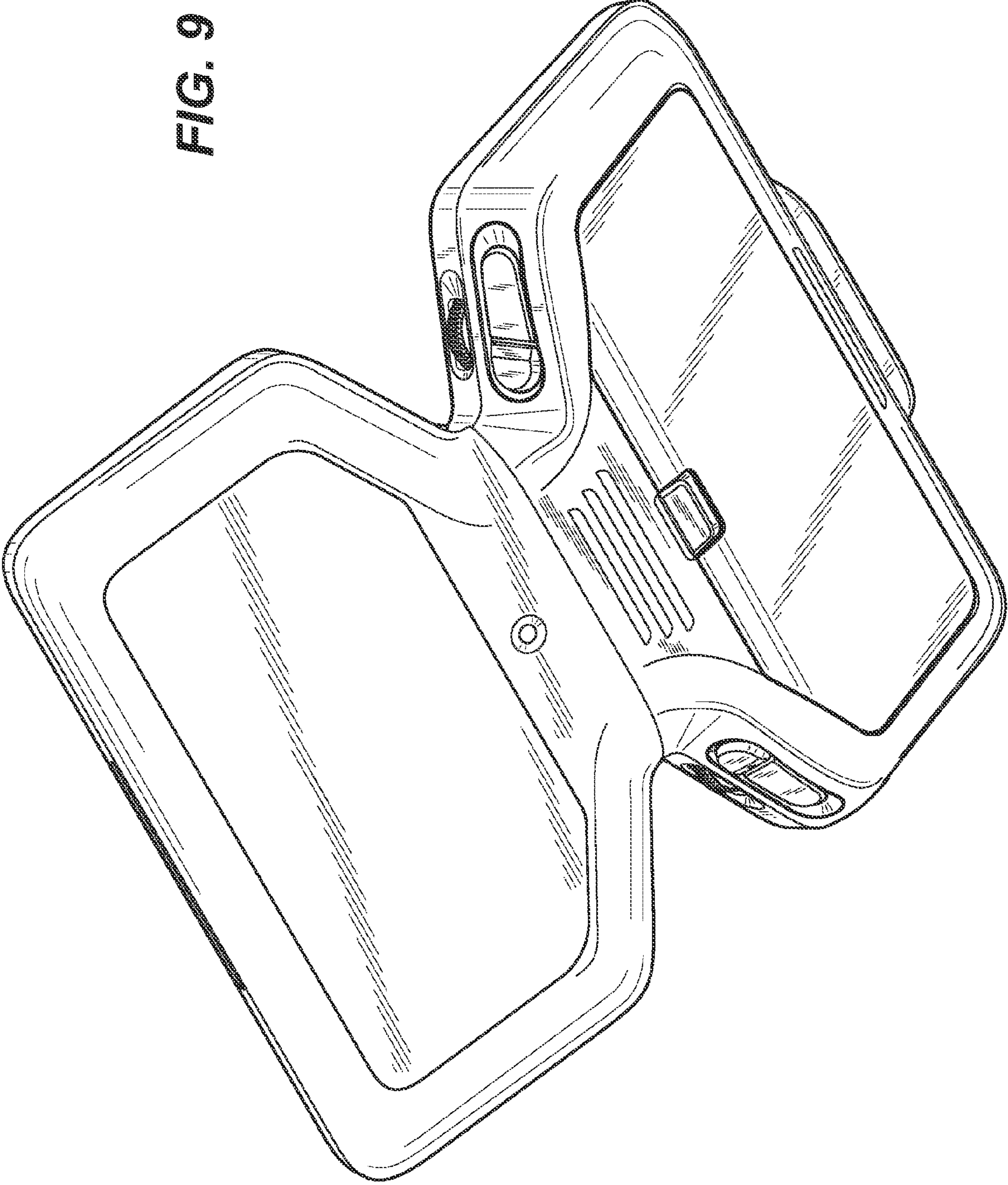

FIG. 8

FIG. 9



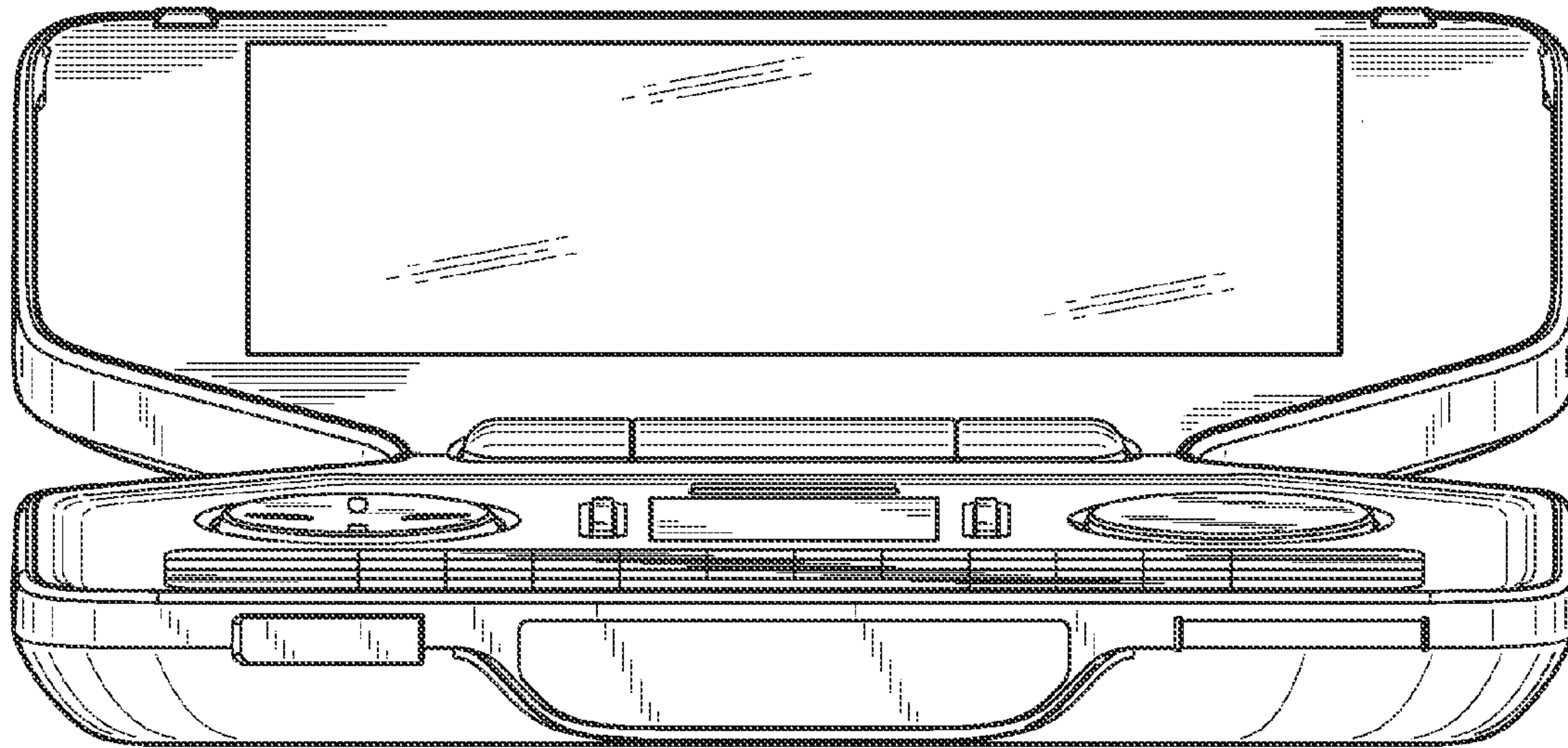

FIG. 10

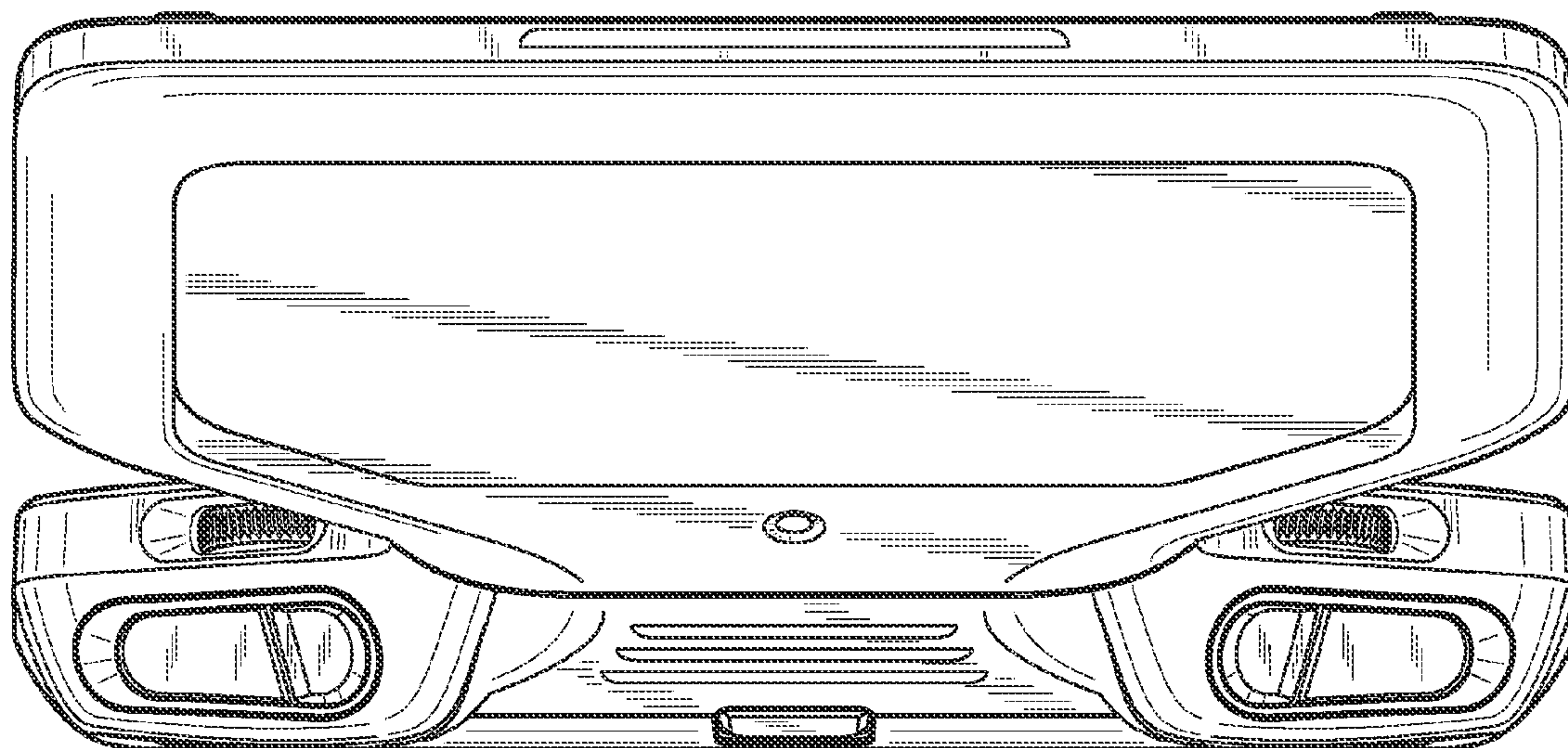

FIG. 11

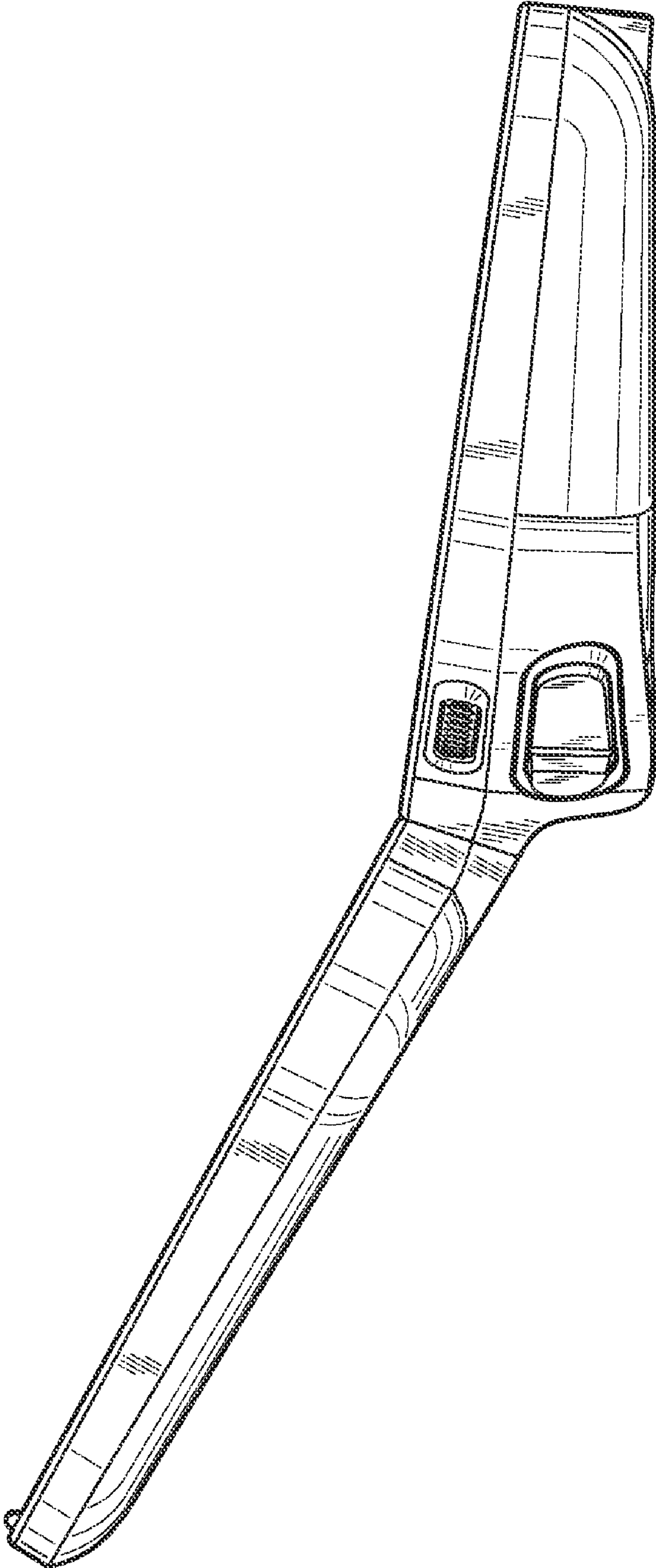

FIG. 12

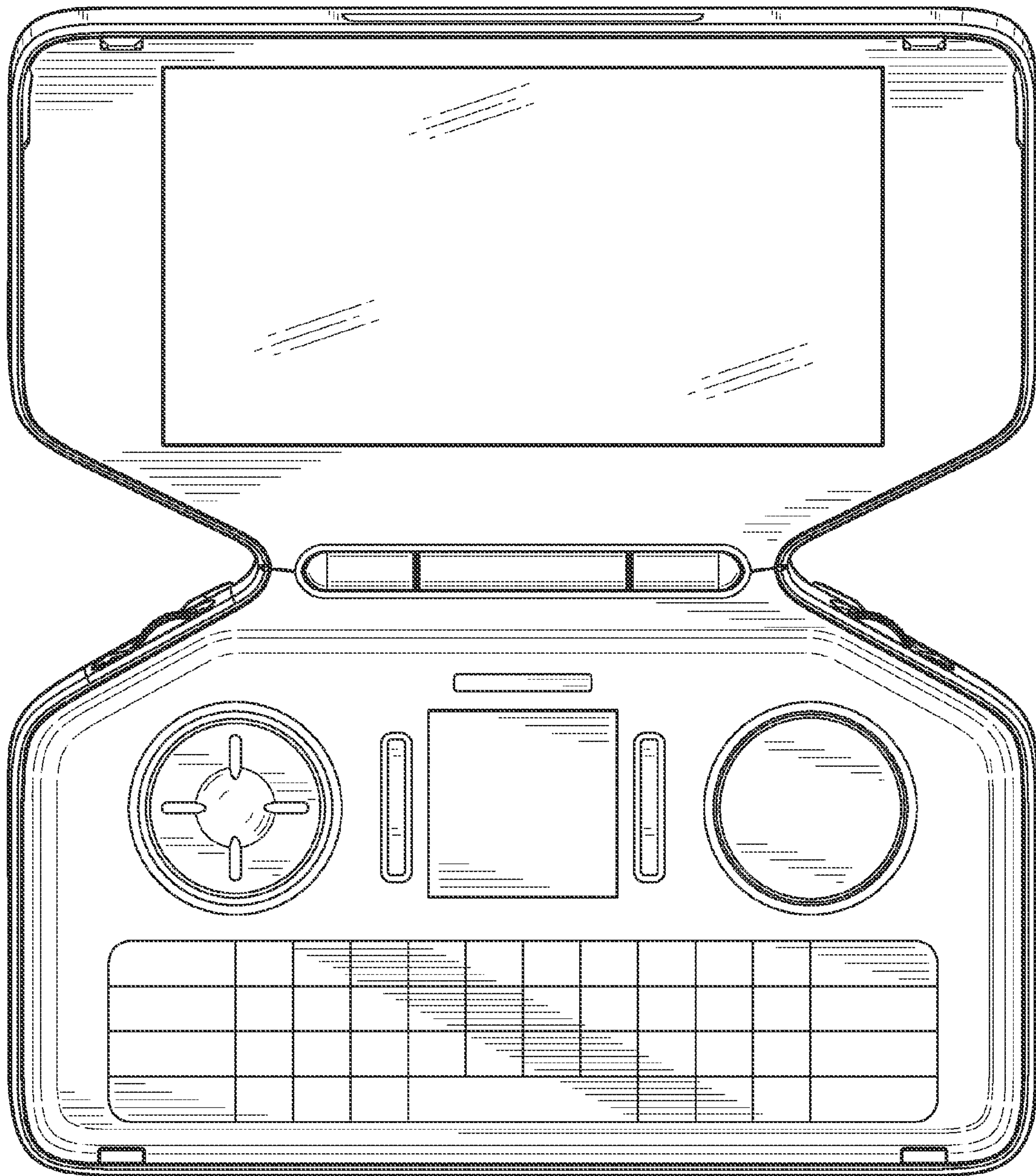

FIG. 13

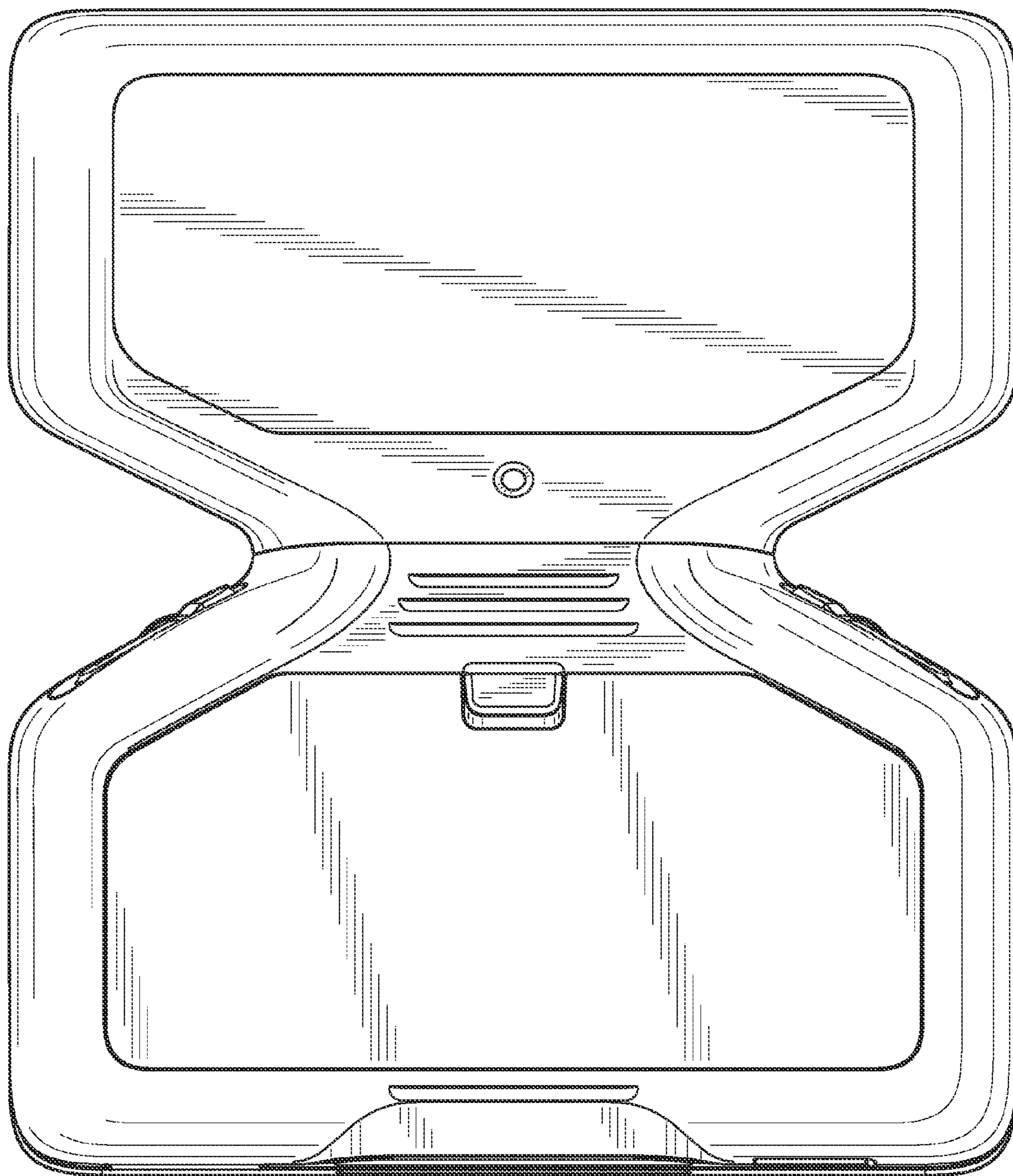

FIG. 14