



US00D637638S

(12) **United States Design Patent**
Noda et al.

(10) **Patent No.:** **US D637,638 S**
(45) **Date of Patent:** **** May 10, 2011**

(54) **CONTROLLER FOR AN ELECTRON MICROSCOPE**

(75) Inventors: **Hiroyuki Noda**, Kokubunji (JP);
Mitsuru Oonuma, Tokyo (JP); **Akira Omachi**, Komae (JP); **Masahiro Nemoto**, Hitachiota (JP); **Kiyoshi Sasagawa**, Honjo (JP)

(73) Assignee: **Hitachi High-Technologies Corporation**, Tokyo (JP)

(**) Term: **14 Years**

(21) Appl. No.: **29/366,703**

(22) Filed: **Jul. 29, 2010**

(30) **Foreign Application Priority Data**

Feb. 22, 2010 (JP) 2010-004043

(51) **LOC (9) Cl.** **16-99**

(52) **U.S. Cl.** **D16/130**

(58) **Field of Classification Search** D16/130,
D16/131; D13/168, 171; D10/46, 75, 104,
D10/106; D14/338, 362, 397, 398, 406,
D14/407, 408, 415, 417, 456, 455, 188, 218,
D14/140.8; D18/11, 12.2; D21/333, 324;
359/393, 368, 381, 392; 386/271, 291; 381/119;
369/4; 379/364

See application file for complete search history.

(56) **References Cited**

U.S. PATENT DOCUMENTS

4,422,105 A * 12/1983 Rodesch et al. 386/291
D291,318 S * 8/1987 Kim D14/407

D292,927 S * 11/1987 Burnstein et al. D14/407
D320,197 S * 9/1991 Weber D14/406
D325,728 S * 4/1992 Mayo et al. D14/338
D330,522 S * 10/1992 Mokhtarian D10/104
5,237,327 A * 8/1993 Saitoh et al. 341/176
D362,695 S * 9/1995 Waldhelm D21/513
D377,320 S * 1/1997 McGuire D10/104
5,946,131 A * 8/1999 Wells et al. 359/350
6,118,581 A * 9/2000 Domanik et al. 359/392
6,148,096 A * 11/2000 Pressman et al. 382/133
D501,861 S * 2/2005 Peter et al. D16/130
D568,827 S * 5/2008 Ikeda et al. D13/168

FOREIGN PATENT DOCUMENTS

JP D1334659 6/2007

* cited by examiner

Primary Examiner — Paula Greene

(74) *Attorney, Agent, or Firm* — Antonelli, Terry, Stout & Kraus, LLP.

(57) **CLAIM**

The ornamental design for a controller for an electron microscope, as shown.

DESCRIPTION

FIG. 1 is a front, top and right side perspective view of a controller for an electron microscope showing our new design;

FIG. 2 is a front elevational view thereof;

FIG. 3 is a rear elevational view thereof;

FIG. 4 is a top plan view thereof;

FIG. 5 is a bottom plan view thereof;

FIG. 6 is a left side elevational view thereof; and,

FIG. 7 is a right side elevational view thereof.

1 Claim, 4 Drawing Sheets

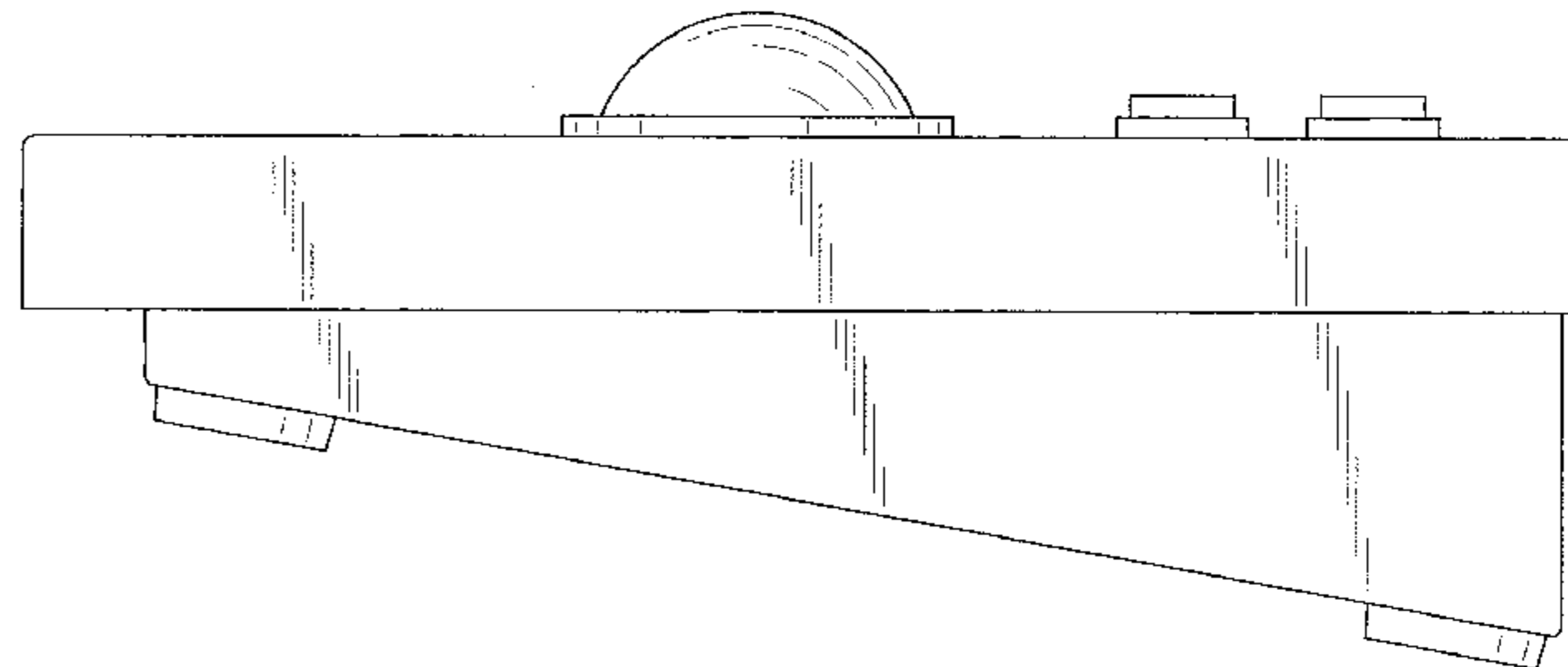
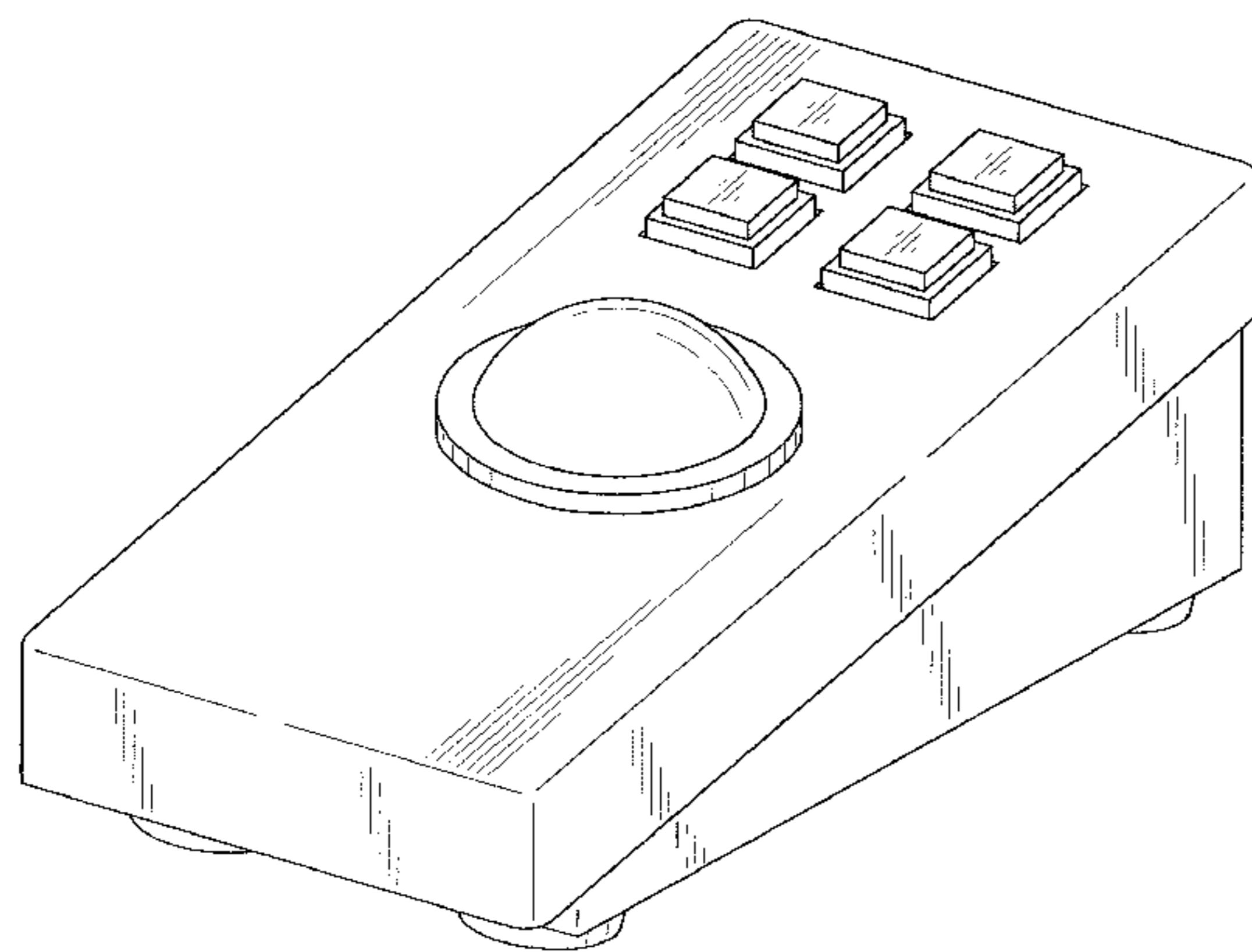

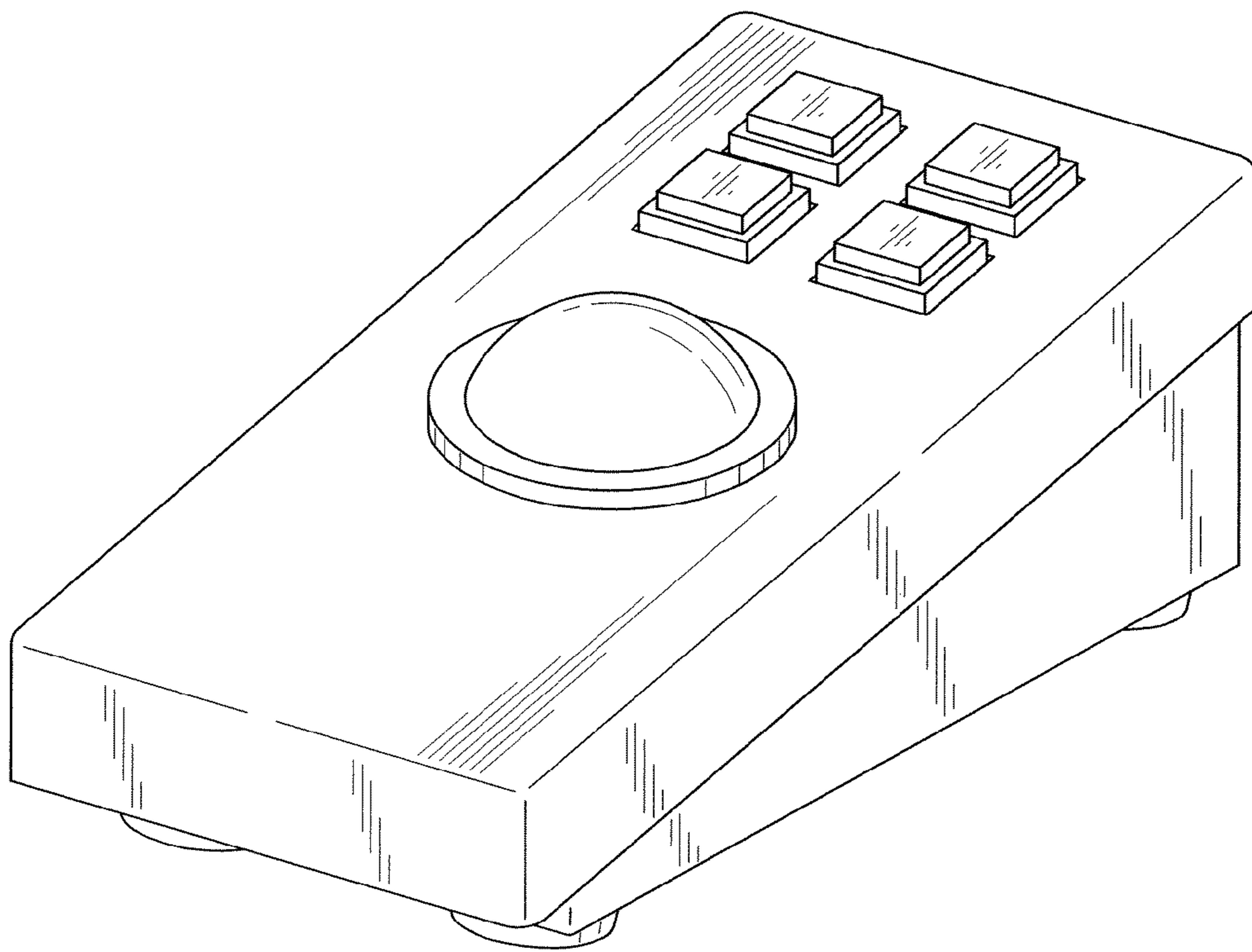

FIG. 1

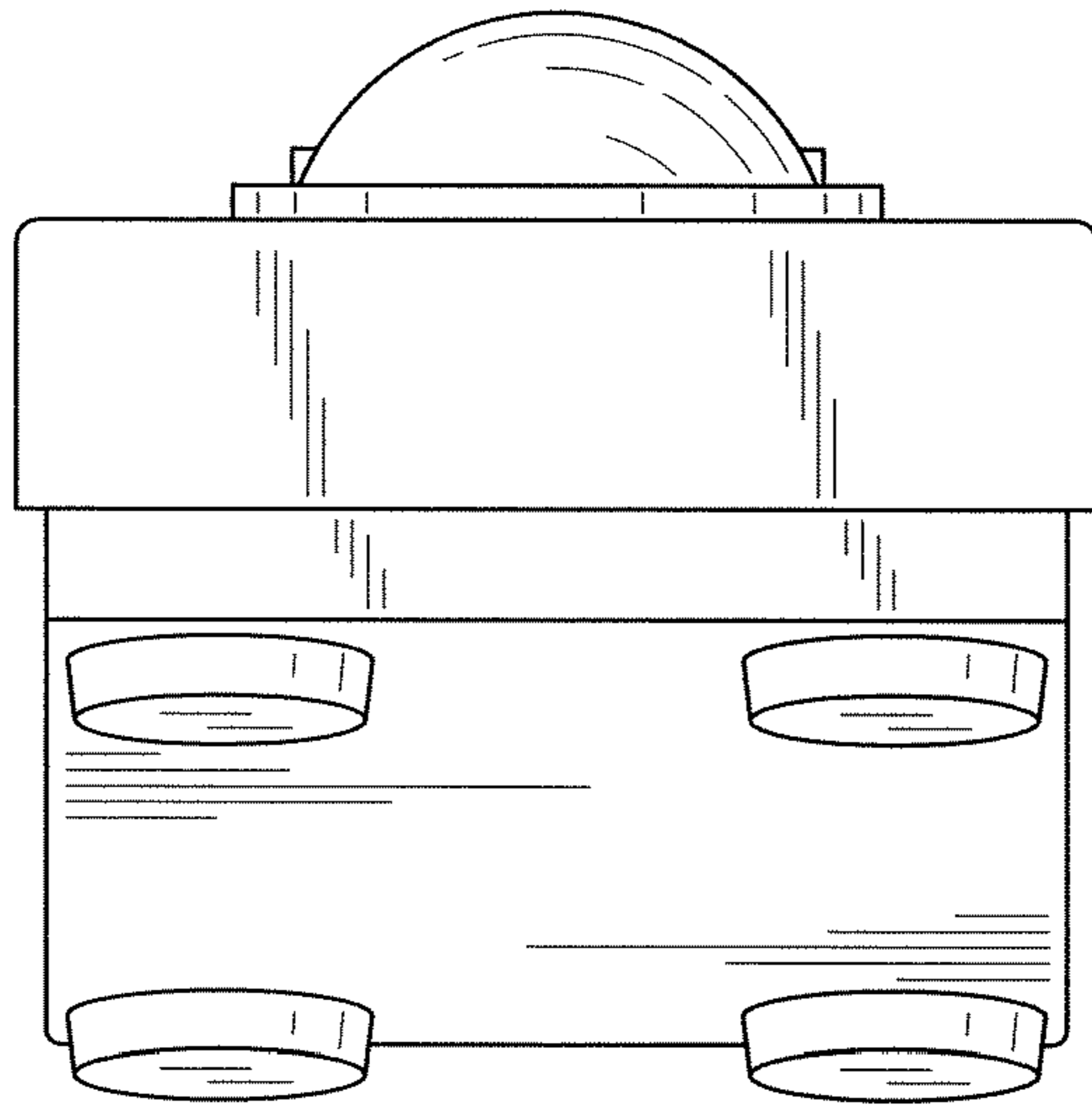

FIG. 2

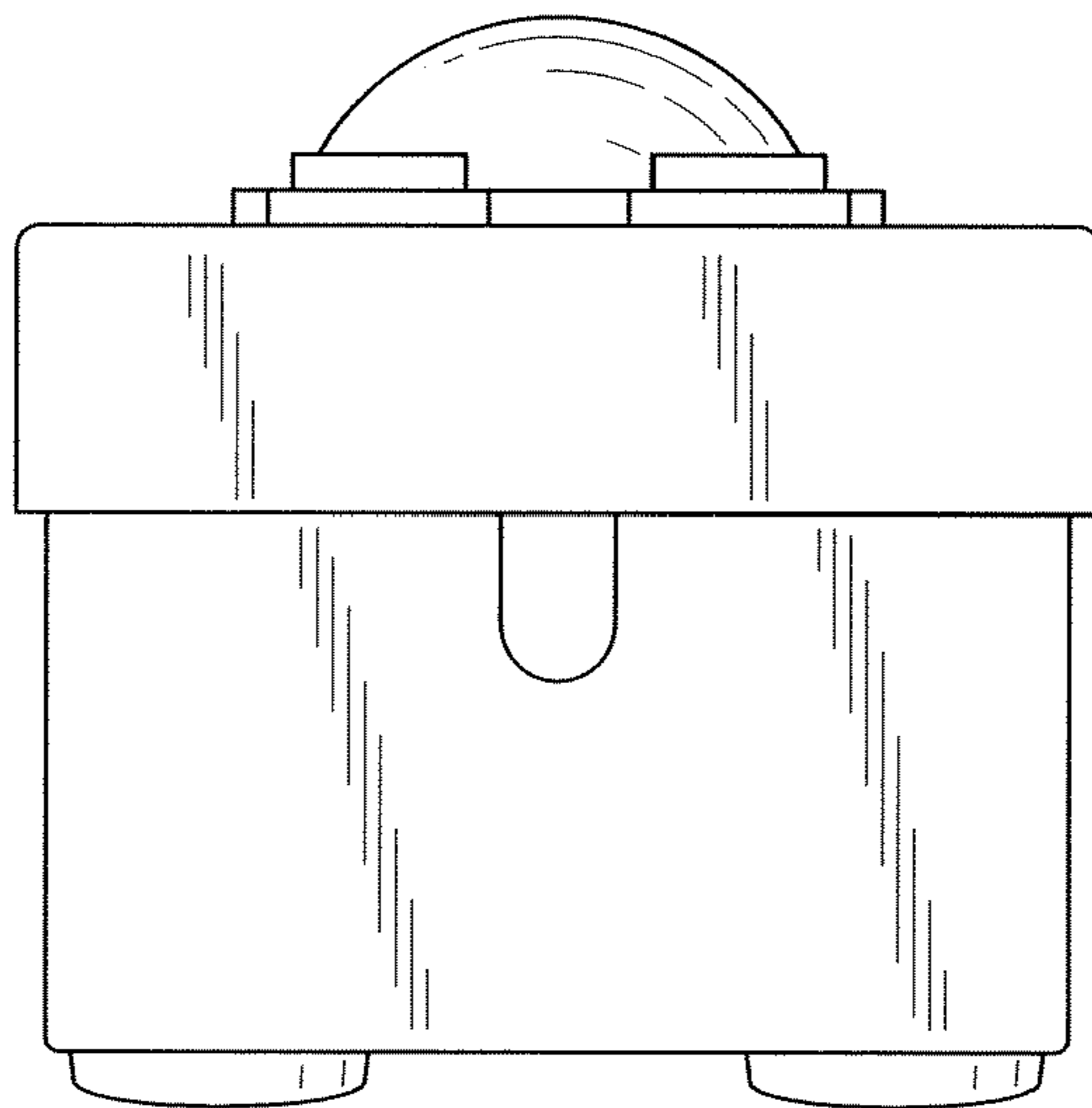

FIG. 3

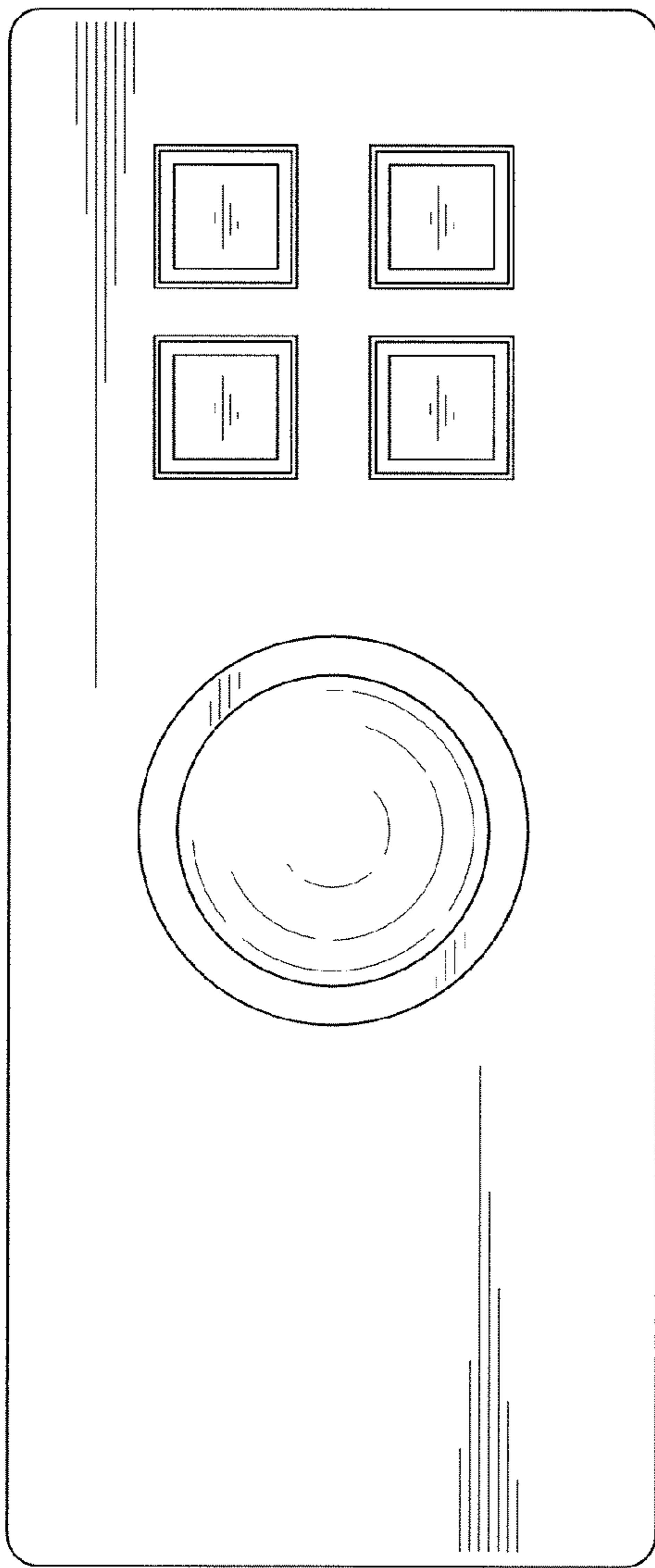

FIG. 4

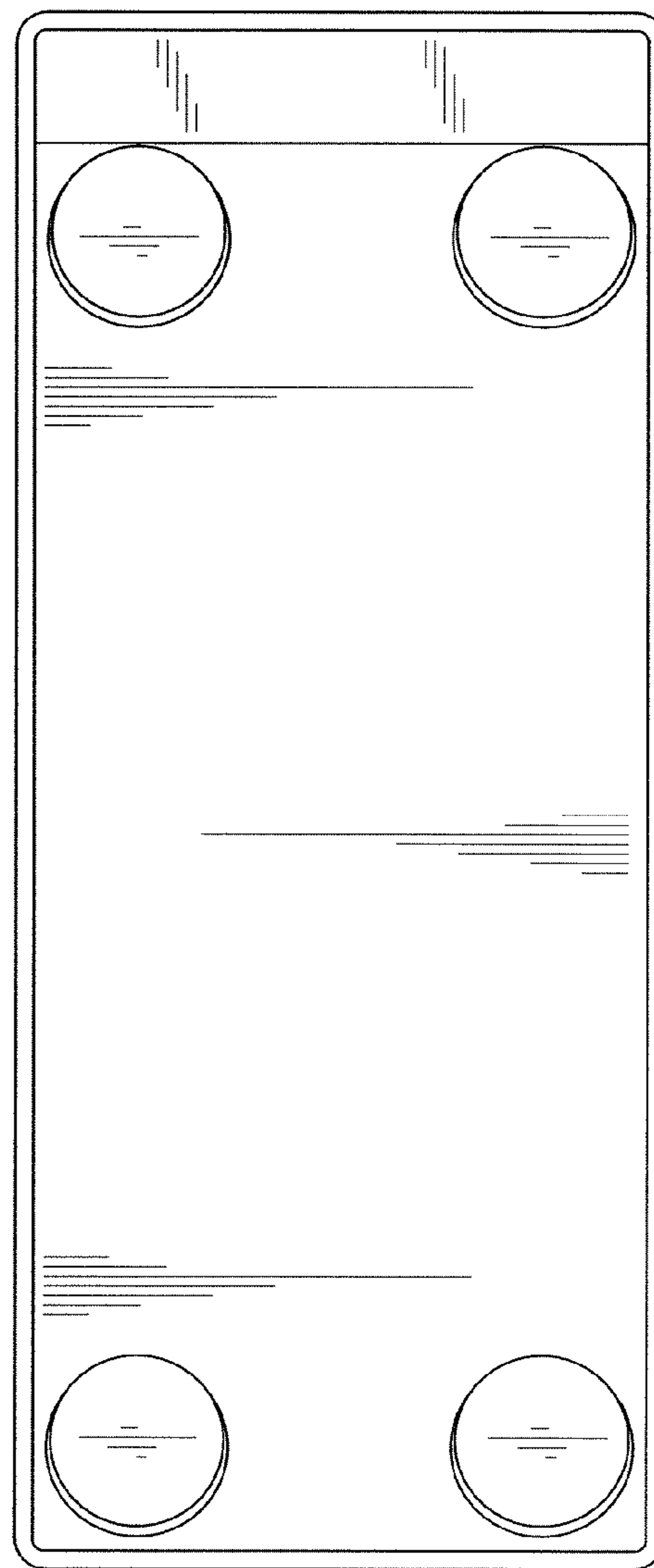

FIG. 5

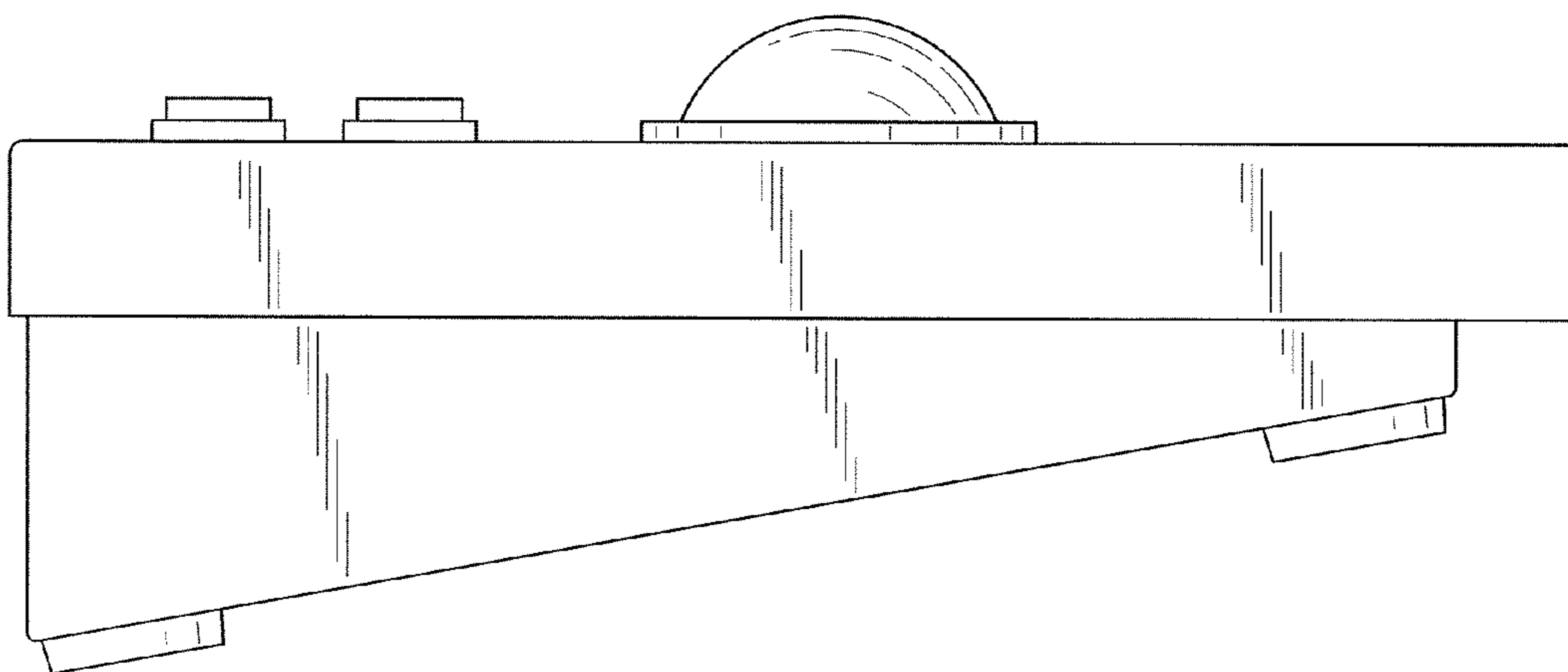

FIG. 6

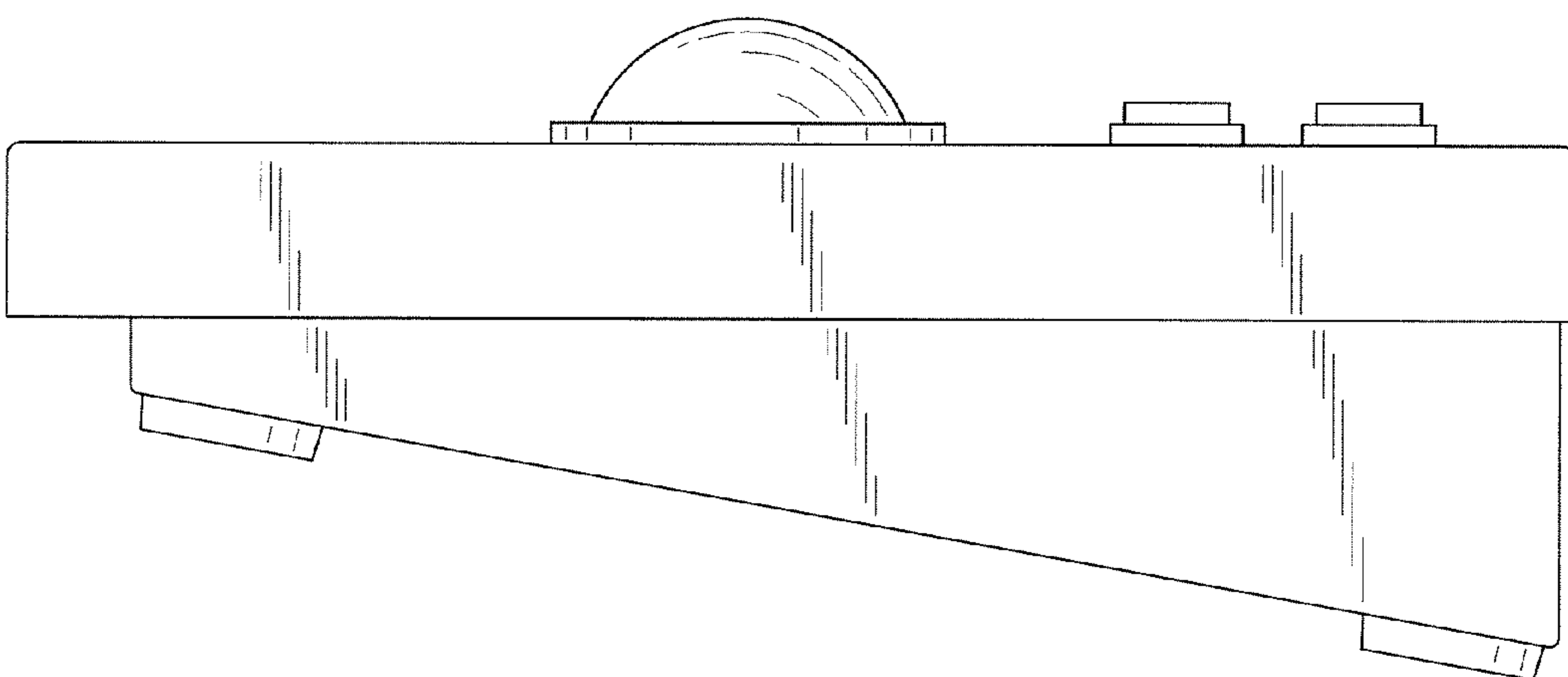

FIG. 7