



US00D637568S

(12) **United States Design Patent**
Desai et al.

(10) **Patent No.:** **US D637,568 S**

(45) **Date of Patent:** **** May 10, 2011**

(54) **FREE-STANDING VIDEO UNIT**

(75) Inventors: **Ashok T. Desai**, Fremont, CA (US);
Steven J. Shiozaki, Belmont, CA (US);
Richard T. Wales, Sunnyvale, CA (US)

(73) Assignee: **Cisco Technology, Inc.**, San Jose, CA
(US)

(**) Term: **14 Years**

(21) Appl. No.: **29/375,619**

(22) Filed: **Sep. 24, 2010**

Related U.S. Application Data

(62) Division of application No. 29/358,009, filed on Mar. 21, 2010, now Pat. No. Des. 628,968.

(51) **LOC (9) Cl.** **14-03**

(52) **U.S. Cl.** **D14/126; D14/129**

(58) **Field of Classification Search** D14/125-134,
D14/239, 371, 136, 374-377, 440, 450, 448,
D14/336, 342; 312/7.2; 348/836, 838, 180,
348/184, 325, 739; 341/12; 248/917-924,
248/465; 345/104, 133, 156, 168, 87, 173;
720/605, 669, 600, 655; 369/99, 197; 455/344,
455/347; D21/329, 515, 577, 622, 333, 433,
D21/448, 452, 450, 331; D6/477, 479, 300;
273/148 B; 446/484, 175, 356; D10/15,
D10/26

See application file for complete search history.

(56) **References Cited**

U.S. PATENT DOCUMENTS

2,911,462 A 11/1959 Brady
3,909,121 A 9/1975 De Mesquita Cardoso
4,853,764 A 8/1989 Sutter

(Continued)

FOREIGN PATENT DOCUMENTS

EP 0 650 299 10/1994

(Continued)

OTHER PUBLICATIONS

U.S. Appl. No. 29/358,006, filed Mar. 21, 2010, entitled "Mounted Video Unit," Inventor(s): Ashok T. Desai et al.

(Continued)

Primary Examiner — Raphael Barkai

(74) *Attorney, Agent, or Firm* — Patent Capital Group

(57) **CLAIM**

The ornamental design for a free-standing video unit, as shown and described.

DESCRIPTION

FIG. 1 is a top perspective view showing a free-standing video unit design according to another embodiment;

FIG. 2 is a front view of the free-standing video unit design of FIG. 1;

FIG. 3 is a back view of the free-standing video unit design of FIG. 1;

FIG. 4 is a side view of the free-standing video unit design of FIG. 1;

FIG. 5 is another side view of the free-standing video unit design of FIG. 1;

FIG. 6 is a top view of the free-standing video unit design of FIG. 1;

FIG. 7 is a bottom view of the free-standing video unit design of FIG. 1;

FIG. 8 is a top perspective view showing a free-standing video unit design according to another embodiment;

FIG. 9 is a front view of the free-standing video unit design of FIG. 8;

FIG. 10 is a back view of the free-standing video unit design of FIG. 8;

FIG. 11 is a side view of the free-standing video unit design of FIG. 8;

FIG. 12 is another side view of the free-standing video unit design of FIG. 8;

FIG. 13 is a top view of the free-standing video unit design of FIG. 8; and,

FIG. 14 is a bottom view of the free-standing video unit design of FIG. 8.

The broken lines of the preceding FIGURES illustrate a boundary and, further, the broken lines are for illustration only and form no part of the claimed design.

1 Claim, 12 Drawing Sheets

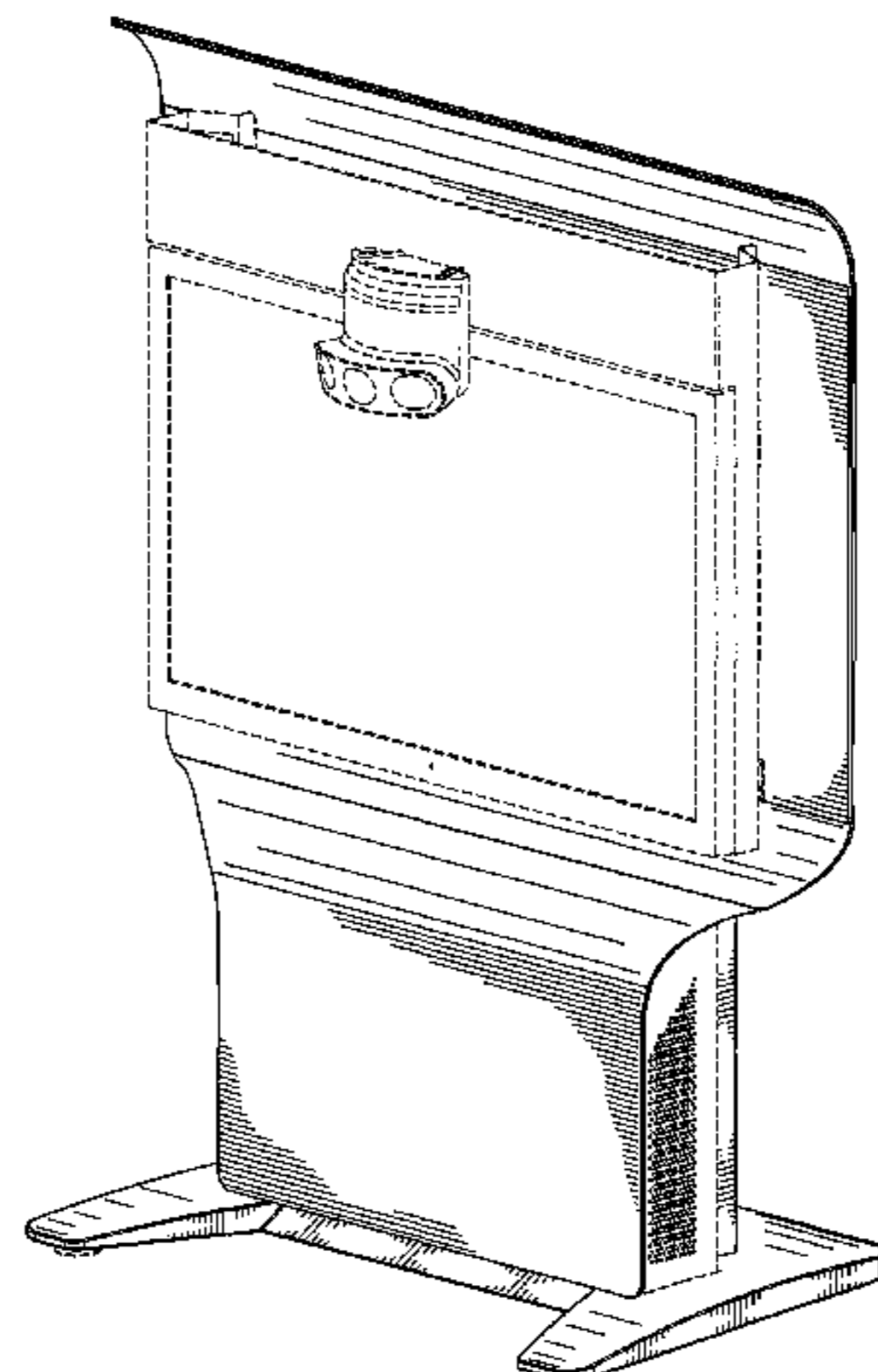

U.S. PATENT DOCUMENTS

4,961,211 A 10/1990 Tsugane et al.
 5,187,571 A 2/1993 Braun et al.
 5,249,035 A 9/1993 Yamanaka
 5,317,405 A 5/1994 Kuriki et al.
 5,347,363 A 9/1994 Yamanaka
 5,532,737 A 7/1996 Braun
 5,541,773 A 7/1996 Kamo et al.
 5,666,153 A 9/1997 Copeland
 5,675,374 A 10/1997 Kohda
 5,729,471 A 3/1998 Jain et al.
 5,748,121 A 5/1998 Romriell
 5,760,826 A 6/1998 Nayar
 5,790,182 A 8/1998 Hilaire
 5,815,196 A 9/1998 Alshawi
 6,124,896 A 9/2000 Kurashige
 6,148,092 A 11/2000 Qian
 6,167,162 A 12/2000 Jacquin et al.
 6,226,035 B1 5/2001 Korein et al.
 6,249,318 B1 6/2001 Girod et al.
 6,285,392 B1 9/2001 Satoda et al.
 6,424,377 B1 7/2002 Driscoll, Jr.
 6,493,032 B1 12/2002 Wallerstein et al.
 6,583,808 B2 6/2003 Boulanger et al.
 6,704,048 B1 3/2004 Malkin et al.
 6,980,526 B2 12/2005 Jang et al.
 6,990,086 B1 1/2006 Holur et al.
 7,002,973 B2 2/2006 MeLampy et al.
 7,028,092 B2 4/2006 MeLampy et al.
 7,031,311 B2 4/2006 MeLampy et al.
 7,057,662 B2 6/2006 Malzbender
 7,080,157 B2 7/2006 McCanne
 7,061,896 B2 8/2006 Jabbari et al.
 7,111,045 B2 9/2006 Kato et al.
 7,136,651 B2 11/2006 Kalavade
 D533,525 S 12/2006 Arie
 D533,852 S 12/2006 Ma
 D534,511 S 1/2007 Maeda et al.
 D535,954 S 1/2007 Hwang et al.
 7,161,942 B2 1/2007 Chen et al.
 D539,243 S 3/2007 Chiu et al.
 D541,773 S 5/2007 Chong et al.
 D542,247 S 5/2007 Kinoshita et al.
 7,246,118 B2 7/2007 Chastain et al.
 D550,635 S 9/2007 DeMaio et al.
 D551,184 S 9/2007 Kanou et al.
 D555,610 S 11/2007 Yang et al.
 D567,202 S 4/2008 Rieu Piquet
 7,353,279 B2 4/2008 Durvasula et al.
 7,359,731 B2 4/2008 Choksi
 7,411,975 B1 8/2008 Mohaban
 7,428,000 B2 9/2008 Cutler et al.
 D578,496 S 10/2008 Leonard
 7,471,320 B2 12/2008 Malkin et al.
 7,477,657 B1 1/2009 Murphy et al.
 D588,560 S 3/2009 Mellingen et al.
 7,518,051 B2 4/2009 Redmann
 7,545,761 B1 6/2009 Kalbag
 D602,453 S 10/2009 Ding et al.
 7,616,226 B2 11/2009 Roessler et al.
 D610,560 S 2/2010 Chen
 D615,514 S 5/2010 Mellingen et al.
 2002/0140804 A1 10/2002 Colmenarez et al.
 2002/0149672 A1 10/2002 Clapp et al.
 2004/0061787 A1 4/2004 Liu et al.
 2004/0164858 A1 8/2004 Lin
 2004/0246962 A1 12/2004 Kopeikin et al.
 2004/0254982 A1 12/2004 Hoffman et al.
 2004/0260796 A1 12/2004 Sundqvist et al.
 2005/0007954 A1 1/2005 Sreemanthula et al.
 2005/0147257 A1 7/2005 Melchior et al.
 2006/0017807 A1 1/2006 Lee et al.
 2006/0120307 A1 6/2006 Nozomu
 2006/0152489 A1 7/2006 Sweetser et al.
 2007/0039030 A1 2/2007 Romanowich et al.
 2007/0140337 A1 6/2007 Lim et al.
 2007/0206556 A1 9/2007 Yegani et al.
 2007/0217406 A1 9/2007 Riedel et al.
 2008/0077390 A1 3/2008 Nagao

2008/0240237 A1 10/2008 Tian et al.
 2008/0240571 A1 10/2008 Tian et al.
 2008/0303901 A1 12/2008 Variyath et al.
 2009/0122867 A1 5/2009 Mauchly et al.
 2009/0207233 A1 8/2009 Mauchly et al.
 2009/0207234 A1 8/2009 Chen et al.
 2009/0244257 A1 10/2009 MacDonald et al.
 2009/0256901 A1 10/2009 Mauchly et al.
 2009/0324023 A1 12/2009 Tian et al.
 2010/0082557 A1 4/2010 Gao et al.
 2010/0123770 A1 5/2010 Friel et al.
 2010/0225732 A1 9/2010 De Beer et al.
 2010/0225735 A1 9/2010 Shaffer et al.
 2010/0283829 A1 11/2010 De Beer et al.

FOREIGN PATENT DOCUMENTS

EP 0 714 081 11/1995
 EP 0 740 177 4/1996
 EP 1 178 352 A1 6/2002
 EP 1 589 758 A1 10/2005
 EP 2073543 A1 6/2009
 GB 2 294 605 A 5/1996
 GB 2355876 A 5/2001
 WO WO 1994/16517 7/1994
 WO WO 1996/21321 7/1996
 WO WO 1997/08896 3/1997
 WO WO 1998/047291 10/1998
 WO WO 1999/059026 11/1999
 WO WO 2005/013001 A2 2/2005
 WO WO 2005/013001 A3 2/2005
 WO WO 2007/123960 A2 11/2007
 WO WO 2007/123960 A3 11/2007
 WO WO 2008/040258 4/2008
 WO WO 2008/101117 A1 8/2008
 WO WO 2008/118887 A2 10/2008
 WO WO 2008/118887 A3 10/2008
 WO WO 2009/102503 A2 8/2009
 WO WO 2009/102503 A3 8/2009
 WO WO 2009/120814 A2 10/2009
 WO WO 2009/120814 A3 10/2009
 WO WO 2010/059481 5/2010
 WO WO 2010/104765 9/2010
 WO WO 2010/132271 11/2010

OTHER PUBLICATIONS

U.S. Appl. No. 29/358,007, filed Mar. 21, 2010, entitled "Video Unit With Integrated Features," Inventor(s): Kyle A. Buzzard et al.
 U.S. Appl. No. 29/358,008, filed Mar. 21, 2010, entitled "Video Unit With Integrated Features," Inventor(s): Kyle A. Buzzard et al.
 U.S. Appl. No. 12/366,593, filed Feb. 5, 2009, entitled "System and Method for Depth Perspective Image Rendering," Inventor(s): J. William Mauchly et al.
 U.S. Appl. No. 12/475,075, filed May 29, 2009, entitled "System and Method for Extending Communications Between Participants in a Conferencing Environment," Inventor(s): Brian J. Baldino et al.
 U.S. Appl. No. 12/539,461, filed Aug. 11, 2009, entitled "System and Method for Verifying Parameters in an Audiovisual Environment," Inventor: James M. Alexander.
 U.S. Appl. No. 12/727,089, filed Mar. 18, 2010, entitled "System and Method for Enhancing Video Images in a Conferencing Environment," Inventor: Joseph T. Friel.
 U.S. Appl. No. 12/784,257, filed May 20, 2010, entitled "Implementing Selective Image Enhancement," Inventors: Dihong Tian et al.,
 U.S. Appl. No. 12/870,687, filed Aug. 27, 2010, entitled "System and Method for Producing a Performance Via Video Conferencing in a Network Environment," Inventor(s): Michael A. Arnao et al.
 U.S. Appl. No. 12/873,100, filed Aug. 31, 2010, entitled "System and Method for Providing Depth Adaptive Video Conferencing," Inventor(s): J. William Mauchly et al.
 U.S. Appl. No. 12/877,833, filed Sep. 8, 2010, entitled "System and Method for Skip Coding During Video Conferencing in a Network Environment," Inventor(s): Dihong Tian, et al.
 U.S. Appl. No. 12/907,914, filed Oct. 19, 2010, entitled "System and Method for Providing VideoMail in a Network Environment," Inventor(s): David J. Mackie et al.

- U.S. Appl. No. 12/907,919, filed Oct. 19, 2010, entitled "System and Method for Providing Connectivity in a Network Environment," Inventor(s): David J. Mackie et al.
- U.S. Appl. No. 12/907,927, filed Oct. 19, 2010, entitled "System and Method for Providing a Paring Mechanism in a Video Environment," Inventor(s): Gangfeng Kong et al.
- U.S. Appl. No. 12/946,679, filed Nov. 15, 2010, entitled "System and Method for Providing Camera Functions in a Video Environment," Inventor(s): Peter A.J. Fornell et al.
- U.S. Appl. No. 12/946,695, filed Nov. 15, 2010, entitled "System and Method for Providing Enhanced Audio in a Video Environment," Inventor(s): Wei Li et al.
- U.S. Appl. No. 12/946,704, filed Nov. 15, 2010, entitled "System and Method for Providing Enhanced Graphics in a Video Environment," Inventor(s): John M. Kanalakakis, Jr., et al.
- U.S. Appl. No. 12/946,709, filed Nov. 15, 2010, entitled "System and Method for Providing Enhanced Graphics in a Video Environment," Inventor(s): John M. Kanalakakis, Jr. et al.
- U.S. Appl. No. 12/939,037, filed Nov. 3, 2010, entitled "System and Method for Managing Flows in a Mobile Network Environment," Inventor(s): Balaji Venkat Venkataswami et al.
- U.S. Appl. No. 12/912,556, filed Oct. 26, 2010, entitled "System and Method for Provisioning Flows in a Mobile Network Environment," Inventor(s): Balaji Venkat Venkataswami et al.
- U.S. Appl. No. 12/950,786, filed Nov. 19, 2010, entitled "System and Method for Providing Enhanced Video Processing in a Network Environment," Inventor(s): David J. Mackie.
- U.S. Appl. No. 12/781,722, filed May 17, 2010, entitled "System and Method for Providing Retracting Optics in a Video Conferencing Environment," Inventor(s): Joseph T. Friel, et al.
- U.S. Appl. No. 12/949,614, filed Nov. 18, 2010, entitled "System and Method for Managing Optics in a Video Environment," Inventor(s): Torence Lu et al.
- U.S. Appl. No. 29/358,009, filed Mar. 21, 2010, entitled "Free-Standing Video Unit," Inventor(s): Ashok T. Desai et al.
- "3D Particles Experiments in AS3 and Flash C53," [retrieved and printed on Mar. 18, 2010]; 2 pages; <http://www.flashandmath.com/advanced/fourparticles/notes.html>.
- 3G, "World's First 3G Video Conference Service with New TV Commercial," Apr. 28, 2005, 4 pages; <http://www.3g.co.uk/PR/April2005/1383.htm>.
- active8-3D—Holographic Projection—3D Hologram Retail Display & Video Project, [retrieved and printed on Feb. 24, 2009], http://www.activ8-3d.co.uk/3d_holocubes; 1 page.
- Andersson, L., et al., "LDP Specification," Network Working Group, RFC 3036, Jan. 2001, 133 pages; <http://tools.ietf.org/html/rfc3036>.
- Arrington, Michael, "eJamming—Distributed Jamming," TechCrunch; Mar. 16, 2006; <http://www.techcrunch.com/2006/03/16/ejamming-distributed-jamming/>; 1 page.
- Avrithis, Y., et al., "Color-Based Retrieval of Facial Images," European Signal Processing Conference (EUSIPCO '00), Tampere, Finland; Sep. 2000; <http://www.image.ece.ntua.gr/~ntsap/presentations/eusipco00.ppt#256>; 18 pages.
- Awduche, D., et al., "Requirements for Traffic Engineering over MPLS," Network Working Group, RFC 2702, Sep. 1999, 30 pages; <http://tools.ietf.org/pdf/rfc2702.pdf>.
- Bakstein, Hynek, et al., "Visual Fidelity of Image Based Rendering," Center for Machine Perception, Czech Technical University, Proceedings of the Computer Vision, Winter 2004, <http://www.benogo.dk/publications/Bakstein-Pajdla-CVWW04.pdf>; 10 pages.
- Beesley, S.T.C., et al., "Active Macroblock Skipping in the H.264 Video Coding Standard," in Proceedings of 2005 Conference on Visualization, Imaging, and Image Processing—VIIP 2005, Sep. 7-9, 2005, Benidorm, Spain, Paper 480-261. ACTA Press, ISBN: 0-88986-528-0; 5 pages.
- Berzin, O., et al., "Mobility Support Using, MPLS and MP-BGP Signaling," Network Working Group, Apr. 28, 2008, 60 pages; <http://www.potaroo.net/ietf/all-ids/draft-berzin-malis-mpls-mobility-01.txt>.
- Boccaccio, Jeff; CEPro, "Inside HDMI CEC: The Little-Known Control Feature," Dec. 28, 2007; http://www.cepro.com/article/print/inside_hdmi_cec_the_little_known_control_feature; 2 pages.
- Bücken R: "Bildfernsehen: Videokonferenz vom Arbeitsplatz aus" Funkschau, Weka Fachzeitschriften Verlag, Poing, DE, No. 17, Aug. 14, 1986, pp. 41-43, XP002537729; ISSN: 0016-2841, p. 43, left-hand column, line 34-middle column, line 24.
- Chan, Eric, et al., "Experiments on block-matching techniques for video coding," Multimedia Systems; 9 Springer—Verlag 1994, Multimedia Systems (1994) 2 pages.
- Chen et al., "Toward a Compelling Sensation of Telepresence: Demonstrating a Portal to a Distant (Static) Office," Proceedings Visualization 2000; VIS 2000; Salt Lake City, UT, Oct. 8-13, 2000; Annual IEEE Conference on Visualization, Los Alamitos, CA; IEEE Comp. Soc., US, Jan. 1, 2000, pp. 327-333; <http://citeseerx.ist.psu.edu/viewdoc/summary?doi=10.1.1.35.1287>.
- Chen, Jason, "iBluetooth Lets iPhone Users Send and Receive Files Over Bluetooth," Mar. 13, 2009; <http://i.gizmodo.com/5169545/ibluetooth-lets-iphone-users-send-and-receive-files-over-bluetooth>; 1 page.
- "Cisco Expo Germany 2009 Opening," Posted on YouTube on May 4, 2009; <http://www.youtube.com/watch?v=SDKsaSlz4MK>; 2 pages.
- Cisco: Bill Mauchly and Mod Marathe; UNC: Henry Fuchs, et al., "Depth-Dependent Perspective Rendering," Apr. 15, 2008; 6 pages.
- Costa, Cristina, et al., "Quality Evaluation and Nonuniform Compression of Geometrically Distorted Images Using the Quadtree Distortion Map," EURASIP Journal on Applied Signal Processing, Jan. 7, 2004, vol. 2004, No. 12; © 2004 Hindawi Publishing Corp.; XP002536356; ISSN: 1110-8657; pp. 1899-1911; <http://downloads.hindawi.com/journals/asp/2004/470826.pdf>.
- Criminisi, A., et al., "Efficient Dense-Stereo and Novel-view Synthesis for Gaze Manipulation in One-to-one Teleconferencing," Technical Rpt MSR-TR-2003-59, Sep. 2003 [retrieved and printed on Feb. 26, 2009], http://research.microsoft.com/pubs/67266/criminisi_techrep2003-59.pdf, 41 pages.
- Daly, S., et al., "Face-based visually-optimized image sequence coding" Image Processing, 1998. ICIP 98. Proceedings; 1998 International Conference on Chicago, IL; Oct. 4-7, 1998, Los Alamitos; IEEE Computing; vol. 3, Oct. 4, 1998; ISBN: 978-0-8186-8821-8; XP010586786; pp. 443-447.
- Diaz, Jesus, "Zcam 3D Camera is Like Wii Without Wiimote and Minority Report Without Gloves," Dec. 15, 2007; <http://gizmodo.com/gadgets/zcam-depth-camera-could-be-wii-challenger/zcam-3d-camera-is-like-wii-without-wiimote-and-minority-report-without-gloves-334426.php>; 3 pages.
- Diaz, Jesus, iPhone Bluetooth File Transfer Coming Soon (YES!); Jan. 26, 2009; <http://i.gizmodo.com/5138797/iphone-bluetooth-file-transfer-coming-soon-yes>; 1 page.
- Digital Video Enterprises, "DVE Eye Contact Silhouette," 1 page, © DVE 2008; <http://www.dvetelepresence.com/products/eyeContactSilhouette.asp>.
- DVE Digital Video Enterprises, "DVE-TeleImmersion Room," [retrieved and printed on Feb. 5, 2009] http://www.dvetelepresence.com/products/immersion_room.asp; 2 pages.
- "Dynamic Displays," copyright 2005-2008 [retrieved and printed on Feb. 24, 2009] http://www.zebraimaging.com/html/lighting_display.html, 2 pages.
- ECmag.com, "IBS Products," Published Apr. 2009; <http://www.ecmag.com/index.cfm?fa=article&articleID=10065>; 2 pages.
- eJamming Audio, Learn More; [retrieved and printed on May 27, 2010] <http://www.ejamming.com/learnmore/>; 4 pages.
- Electrophysics Glossary, "Infrared Cameras, Thermal Imaging, Night Vision, Roof Moisture Detection," [retrieved and printed on Mar. 18, 2010] http://www.electrophysics.com/Browse/Brw_Glossary.asp; 11 pages.
- Farrukh, A., et al., Automated Segmentation of Skin-Tone Regions in Video Sequences, Proceedings IEEE Students Conference, ISCON_02; Aug. 16-17, 2002; pp. 122-128.
- Fiala, Mark, "Automatic Projector Calibration Using Self-Identifying Patterns," National Research Council of Canada, Jun. 20-26, 2005; <http://www.procams.org/procams2005/papers/procams05-36.pdf>; 6 pages.
- Foote, J., et al., "Flycam: Practical Panoramic Video and Automatic Camera Control," in Proceedings of IEEE International Conference on Multimedia and Expo, vol. III, Jul. 30, 2000; pp. 1419-1422; <http://citeseerx.ist.psu.edu/viewdoc/versions?doi=10.1.1.138.8686>.

- “France Telecom’s Magic Telepresence Wall,” Jul. 11, 2006; http://www.humanproductivitylab.com/archive_blogs/2006/07/11/france_telecoms_magic_telepres_1.php; 4 pages.
- Freeman, Professor Wilson T., Computer Vision Lecture Slides, “6.869 Advances in Computer Vision: Learning and Interfaces,” Spring 2005; 21 pages.
- Gemmell, Jim, et al., “Gaze Awareness for Video-conferencing: A Software Approach,” IEEE MultiMedia, Oct.-Dec. 2000; vol. 7, No. 4, pp. 26-35.
- Gotchev, Atanas, “Computer Technologies for 3D Video Delivery for Home Entertainment,” International Conference on Computer Systems and Technologies; CompSysTech, Jun. 12-13, 2008; <http://ecet.ecs.ru.acad.bg/cst08/docs/cp/Plenary/P.1.pdf>; 6 pages.
- Gries, Dan, “3D Particles Experiments in AS3, and Flash CS3, Dan’s Comments,” [retrieved and printed on May 24, 2010] <http://www.flashandmath.com/advanced/fourparticles/notes.html>; 3 pages.
- Guernsey, Lisa, “Toward Better Communication Across the Language Barrier,” Jul. 29, 1999; <http://www.nytimes.com/1999/07/29/technology/toward-better-communication-across-the-language-barrier.html>; 2 pages.
- Guili, D., et al., “Orchestral: A Distributed Platform for Virtual Musical Groups and Music Distance Learning over the Internet in Java™ Technology”; [retrieved and printed on Jun. 6, 2010] <http://ieeexplore.ieee.org/stamp/stamp.jsp?tp=&arnumber=778626>; 2 pages.
- Gundavelli, S., et al., “Proxy Mobile IPv6,” Network Working Group, RFC 5213, Aug. 2008, 93 pages; <http://tools.ietf.org/pdf/rfc5213.pdf>.
- Habili, Nariman, et al., “Segmentation of the Face and Hands in Sign Language Video Sequences Using Color and Motion Cues” IEEE Transaction on Circuits and Systems for Video Technology, IEEE Service Center, vol. 14, No. 8, Aug. 1, 2004; ISSN: 1051-8215; XP011115755; pp. 1086-1097.
- He, L., et al., “The Virtual Cinematographer: A Paradigm for Automatic Real-Time Camera Control and Directing,” Proc. SIGGRAPH, © 1996; <http://research.microsoft.com/en-us/um/people/lhe/papers/siggraph96.vc.pdf>; 8 pages.
- Hepper, D., “Efficiency Analysis and Application of Uncovered Background Prediction in a Low BitRate Image Coder,” IEEE Transactions on Communications, vol. 38, No. 9, pp. 1578-1584, Sep. 1990.
- Holographic Imaging, “Dynamic Holography for scientific uses, military heads up display and even someday HoloTV Using TI’s DMD,” [retrieved and printed on Feb. 26, 2009] http://innovation.swmed.edu/research/instrumentation/res_inst_dev3d.html; 5 pages.
- Hornbeck, Larry J., “Digital Light Processing™: A New MEMS-Based Display Technology,” [retrieved and printed on Feb. 26, 2009] http://focus.ti.com/pdfs/dipdmd/17_Digital_Light_Processing_MEMS_display_technology.pdf; 22 pages.
- “Infrared Cameras TVS-200-EX,” [retrieved and printed on May 24, 2010] http://www.electrophysics.com/Browse/Brw_ProductLineCategory.asp?CategoryID=184&Area=IS; 2 pages.
- IR Distribution Category @ Envious Technology, “IR Distribution Category,” [retrieved and printed on Apr. 22, 2009] <http://www.envioustechnology.com.au/products/product-list.php?CID=305>; 2 pages.
- IR Trans—Products and Orders—Ethernet Devices, [retrieved and printed on Apr. 22, 2009] <http://www.irtrans.de/en/shop/lan.php>; 2 pages.
- Isgro, Francesco et al., “Three-Dimensional Image Processing in the Future of Immersive Media,” IEEE Transactions on Circuits and Systems for Video Technology, vol. 14, No. 3; XP011108796; ISSN: 1051-8215; Mar. 1, 2004; pp. 288-303.
- Itoh, Hiroyasu, et al., “Use of gain modulating framing camera for time-resolved imaging of cellular phenomena,” SPIE vol. 2979, 1997, pp. 733-740.
- Jamoussi, Bamil, “Constraint-Based LSP Setup Using LDP,” MPLS Working Group, Sep. 1999, 34 pages; <http://tools.ietf.org/html/draft-ietf-mpls-cr-ldp-03>.
- Jeyathan, M., et al., “3GPP TFT Reference for Flow Binding,” MEXT Working Group, Mar. 2, 2010, 11 pages; <http://www.ietf.org/Id/draft-jeyathan-mext-flow-tftemp-reference-00.txt>.
- Jiang, Minqiang, et al., “On Lagrange Multiplier and Quantizer Adjustment for H.264 Frame-layer Video Rate Control,” IEEE Transactions on Circuits and Systems for Video Technology, vol. 16, Issue 5, May 2006, pp. 663-669.
- Joshua Gluckman and S.K. Nayar, “Rectified Catadioptric Stereo Sensors,” 8 pages, retrieved and printed on May 17, 2010; <http://cis.poly.edu/~gluckman/papers/cvpr00.pdf>.
- Kannangara, C.S., et al., “Complexity Reduction of H.264 Using Lagrange Multiplier Methods,” IEEE Int. Conf. on Visual Information Engineering , Apr. 2005; www.rgu.ac.uk/files/h264_complexity_kannangara.pdf; 6 pages.
- Kannangara, C.S., et al., “Low Complexity Skip Prediction for H.264 through Lagrangian Cost Estimation,” IEEE Transactions on Circuits and Systems for Video Technology, vol. 16, No. 2, Feb. 2006; www.rgu.ac.uk/files/h264_skippredict_richardson_final.pdf; 20 pages.
- Kauff, Peter, et al., “An Immersive 3D Video-Conferencing System Using Shared Virtual Team User Environments,” Proceedings of the 4th International Conference on Collaborative Virtual Environments, XP040139458; Sep. 30, 2002; http://ip.hhi.de/imedia_G3/assets/pdfs/CVE02.pdf; 8 pages.
- Kazutake, Uehira, “Simulation of 3D image depth perception in a 3D display using two stereoscopic displays at different depths,” Jan. 30, 2006; <http://adsabs.harvard.edu/abs/2006SPIE.6055.408U>; 2 pages.
- Keijsers, Jeroen, et al., “Exploring 3D Interaction in Alternate Control-Display Space Mappings,” IEEE Symposium on 3D User Interfaces, Mar. 10-11, 2007, pp. 17-24.
- Kim, Y.H., et al., “Adaptive mode decision for H.264 encoder,” Electronics letters, vol. 40, Issue 19, pp. 1172-1173, Sep. 2004; 2 pages.
- Klint, Josh, “Deferred Rendering in Leadwerks Engine,” Copyright Leadwerks Corporation © 2008; http://www.leadwerks.com/files/Deferred_Rendering_in_Leadwerks_Engine.pdf; 10 pages.
- Kollarits, et al., “34.3: An Eye Contact Camera/Display System for Videophone Applications Using a Conventional Direct-View LCD,” © 1995 SID, ISSN0097-0966X/95/2601, pp. 765-768; <http://citeseerx.ist.psu.edu/viewdoc/download;jsessionid=47A1E7E028C26503975E633895D114EC?doi=10.1.1.42.1772&rep=rep1&type=pdf>.
- Koyama, S., et al. “A Day and Night Vision MOS Imager with Robust Photonic-Crystal-Based RGB-and-IR” Mar. 2008, pp. 754-759; ISSN: 0018-9383; IEEE Transactions on Electron Devices, vol. 55, No. 3; <http://ieeexplore.ieee.org/stamp/stamp.jsp?tp=&arnumber=4455782&isnumber=4455723>.
- Lawson, S., “Cisco Plans TelePresence Translation Next Year,” Dec. 9, 2008; http://www.pcworld.com/article/155237/.html?tk=rss_news; 2 pages.
- Lee, J. and Jeon, B., “Fast Mode Decision for H.264,” ISO/IEC MPEG and ITU-T VCEG Joint Video Team, Doc. JVT-J033, Dec. 2003; http://media.skku.ac.kr/publications/paper/IntC/Ijy_ICME2004.pdf; 4 pages.
- Liu, Z., “Head-Size Equalization for Better Visual Perception of Video Conferencing,” Proceedings IEEE International Conference on Multimedia & Expo (ICME2005), Jul. 6-8, 2005, Amsterdam, The Netherlands; <http://research.microsoft.com/users/cohen/HeadSizeEqualizationICME2005.pdf>; 4 pages.
- Mann, S., et al., “Virtual Bellows: Constructing High Quality Still from Video,” Proceedings, First IEEE International Conference on Image Processing ICIP-94, Nov. 13-16, 1994, Austin, TX; <http://citeseerx.ist.psu.edu/viewdoc/summary?doi=10.1.1.50.8405>; 5 pages.
- Miller, Gregor, et al., “Interactive Free-Viewpoint Video,” Centre for Vision, Speech and Signal Processing, [retrieved and printed on Feb. 26, 2009], <http://www.ee.surrey.ac.uk/CVSSP/VMRG/Publications/miller05cvmp.pdf>, 10 pages.
- “Minoru from Novo is the worlds first consumer 3D Webcam,” Dec. 11, 2008; <http://www.minoru3d.com>; 4 pages.
- Mitsubishi Electric Research Laboratories, copyright 2009 [retrieved and printed on Feb. 26, 2009], <http://www.merl.com/projects/3dvtv>, 2 pages.
- National Training Systems Association Home—Main, Interservice/Industry Training, Simulation & Education Conference, Dec. 1-4, 2008; <http://ntsa.metapress.com/app/home/main.asp?referrer=default>; 1 page.

- Oh, Hwang-Seok, et al., “Block-Matching Algorithm Based on Dynamic Search Window Adjustment,” Dept. of CS, KAIST, 1997, 6 pages; <http://citeseerx.ist.psu.edu/viewdoc/similar?doi=10.1.1.29.8621&type=ab>.
- Opera Over Cisco Telepresence at Cisco Expo 2009, in Hannover Germany—Apr. 28, 29, posted on YouTube on May 5, 2009; <http://www.youtube.com/watch?v=xN5jNH5E-38>; 1 page.
- OptoIQ, “Vision + Automation Products—VideometerLab 2,” [retrieved and printed on Mar. 18, 2010], <http://www.optoiq.com/optoiq-2/en-us/index/machine-vision-imaging-processing/display/vsd-articles-tools-template.articles.vision-systems-design.volume-11.issue-10.departments.new-products.vision-automation-products.htmlhtml>; 11 pages.
- OptoIQ, “Anti-Speckle Techniques Uses Dynamic Optics,” Jun. 1, 2009; <http://www.optoiq.com/index/photonics-technologies-applications/Ifw-display/Ifw-article-display/363444/articles/optoiq2/photonics-technologies/technology-products/optical-components/optical-mems/2009/12/anti-speckle-techniques-uses-dynamic-optics/QP129867/cmpid=EnlOptoLFWJanuary132010.html>; 2 pages.
- OptoIQ, “Smart Camera Supports Multiple Interfaces,” Jan. 22, 2009; <http://www.optoiq.com/index/machine-vision-images-processing/display/vsd-article-display/350639/articles/vision-systems-design/daily-product-2/2009/01/smart-camera-supports-multiple-interfaces.html>; 2 pages.
- OptoIQ, “Vision Systems Design—Machine Vision and Image Processing Technology,” [retrieved and printed on Mar. 18, 2010], <http://www.optoiq.com/index/machine-vision-imaging-processing.html>; 2 pages.
- Payatagool, Chris, “Orchestral Manoeuvres in the Light of Telepresence,” Telepresence Options, Nov. 12, 2008; http://www.telepresenceoptions.com/2008/11/orchestral_manoeuvres; 2 pages.
- PCT “International Search Report and the Written Opinion of the International Searching Authority, or the Declaration,” PCT/US2010/026456, dated Jun. 29, 2010, 11 pages.
- PCT “Notification of Transmittal of the International Search Report and the Written Opinion of the International Searching Authority, or the Declaration,” PCT/US2009/001070, dated Apr. 4, 2009, 17 pages.
- PCT International Preliminary Report on Patentability mailed Aug. 26, 2010 for PCT/US2009/001070; 10 pages.
- PCT International Preliminary Report on Patentability mailed Oct. 7, 2010 for PCT/US2009/038310; 10 pages.
- PCT International Report of Patentability dated May 15, 2006, for PCT International Application PCT/US2004/021585, 6 pages.
- PCT International Search Report (4 pages), International Preliminary Report on Patentability (1 page), and Written Opinion of the ISA (7 pages); PCT/US2008/058079; dated Sep. 18, 2008.
- PCT International Search Report mailed Aug. 24, 2010 for PCT/US2010033880; 4 pages.
- PCT Notification of Transmittal of the International Search Report and the Written Opinion of the International Searching Authority, or the Declaration; PCT/US2009/038310; dated Oct. 10, 2009. 19 pages.
- PCT Notification of Transmittal of the International Search Report and the Written Opinion of the International Searching Authority, or the Declaration for PCT/US2009/064061 mailed Feb. 23, 2010; 14 pages.
- Pixel Tools “Rate Control and H.264: H.264 rate control algorithm dynamically adjusts encoder parameters,” [retrieved and printed on Jun. 10, 2010] http://www.pixeltools.com/rate_control_paper.html; 7 pages.
- Radhika, N., et al., “Mobile Dynamic reconfigurable Context aware middleware for Adhoc smart spaces,” vol. 22, 2008; <http://www.acadjournal.com/2008/V22/part6/p7>; 3 pages.
- Rayvel Business-to-Business Products, copyright 2004 [retrieved and printed on Feb. 24, 2009], <http://www.rayvel.com/b2b.html>; 2 pages.
- Richardson, I.E.G., et al., “Fast H.264 Skip Mode Selection Using and Estimation Framework,” Picture Coding Symposium, (Beijing, China), Apr. 2006; www.rgu.ac.uk/files/richardson_fast_skip_estimation_pcs06.pdf; 6 pages.
- Richardson, Iain, et al., “Video Encoder Complexity Reduction by Estimating Skip Mode Distortion,” Image Communication Technology Group; [Retrieved and printed Oct. 21, 2010] 4 pages; http://www4.rgu.ac.uk/files/ICIP04_richardson_zhao_final.pdf.
- “Robust Face Localisation Using Motion, Colour & Fusion”; Proc. With Digital Image Computing: Techniques and Applications, Sun C. et al (Eds.), Sydney ; XP007905630; pp. 899-908; Dec. 10, 2003; <http://www.cmis.csiro.au/Hugues.Talbot/dicta2003/cdrom/pdf/0899.pdf>.
- Satoh, Kiyohide et al., “Passive Depth Acquisition for 3D Image Displays”, IEICE Transactions on Information and Systems, Information Systems Society, Tokyo, JP, Sep. 1, 1994, vol. E77-D, No. 9, pp. 949-957.
- School of Computing, “Bluetooth over IP for Mobile Phones,” 2005; http://www.computing.dcu.ie/wwwadmin/fyp-abstract/list/fyp_details05.jsp?year=2005&number=51470574; 1 page.
- Schroeder, Erica, “The Next Top Model—Collaboration,” Collaboration, The Workspace: A New World of Communications and Collaboration, Mar. 9, 2009; http://blogs.cisco.com/collaboration/comments/the_next_top_model; 3 pages.
- Sena, “Industrial Bluetooth,” [retrieved and printed on Apr. 22, 2009] http://www.sena.com/products/industrial_bluetooth; 1 page.
- Shaffer, Shmuel, “Translation—State of the Art” presentation; Jan. 15, 2009; 22 pages.
- Shi, C. et al., “Automatic Image Quality Improvement for Videoconferencing,” IEEE ICASSP May 2004; <http://research.microsoft.com/pubs/69079/0300701.pdf>; 4 pages.
- Shum, H.-Y., et al., “A Review of Image-Based Rendering Techniques,” in SPIE Proceedings vol. 4067(3); Proceedings of the Conference on Visual Communications and Image Processing 2000, Jun. 20-23, 2000, Perth, Australia; pp. 2-13; https://research.microsoft.com/pubs/68826/review_image_rendering.pdf.
- Smarthome, “IR Extender Expands Your IR Capabilities,” [retrieved and printed on Apr. 22, 2009], <http://www.smarthome.com/8121.html>; 3 pages.
- Soliman, H., et al., “Flow Bindings in Mobile IPv6 and NEMO Basic Support,” IETF Mext Working Group, Nov. 9, 2009, 38 pages; <http://tools.ietf.org/html/draft-ietf-mext-flow-binding-04>.
- Sonoma Wireworks Forums, “Jammin on RiffLink,” [retrieved and printed on May 27, 2010] <http://www.sonomawireworks.com/forums/viewtopic.php?id=2659>; 5 pages.
- Sonoma Wireworks RiffLink, [retrieved and printed on Jun. 2, 2010] <http://www.sonomawireworks.com/rifflink.php>; 3 pages.
- SooHuan, Kim, et al., “Block-based face detection scheme using face color and motion estimation,” Real-Time Imaging VIII; Jan. 20-22, 2004, San Jose, CA; vol. 5297, No. 1; Proceedings of the SPIE—The International Society for Optical Engineering SPIE-Int. Soc. Opt. Eng USA ISSN: 0277-786X; XP007905596; pp. 78-88.
- Sudan, Ranjeet, “Signaling in MPLS Networks with RSVP-TE-Technology Information,” Telecommunications, Nov. 2000, 3 pages; http://findarticles.com/p/articles/mi_mOTLC/is_11_34/ai_67447072/.
- Sullivan, Gary J., et al., “Video Compression—From Concepts to the H.264/AVC Standard,” Proceedings IEEE, vol. 93, No. 1, Jan. 2005; http://ip.hhi.de/imagecom_G1/assets/pdfs/piece_sullivan_wiegand_2005.pdf; 14 pages.
- Sun, X., et al., “Region of Interest Extraction and Virtual Camera Control Based on Panoramic Video Capturing,” IEEE Trans. Multimedia, Oct. 27, 2003; <http://vision.ece.ucsb.edu/publications/04mmXdsun.pdf>; 14 pages.
- Super Home Inspectors or Super Inspectors, [retrieved and printed on Mar. 18, 2010] <http://www.umrt.com/PageManager/Default.aspx/PageID=2120325>; 3 pages.
- Total immersion, Video Gallery, copyright 2008-2009 [retrieved and printed on Feb. 26, 2009], <http://www.t-immersion.com/en,video-gallery,36.html>, 1 page.
- Trevor, Darrell, “A Real-Time Virtual Mirror Display,” 1 page, Sep. 9, 1998; <http://people.csail.mit.edu/trevor/papers/1998-021/node6.html>.
- Trucco, E., et al., “Real-Time Disparity Maps for Immersive 3-D Teleconferencing by Hybrid Recursive Matching and Census Transform,” [retrieved and printed on May 4, 2010] <http://server.cs.ucf.edu/~vision/papers/VidReg-final.pdf>; 9 pages.

- Tsapatsoulis, N., et al., "Face Detection for Multimedia Applications" Proceedings of the ICIP Sep. 10-13, 2000, Vancouver, BC, Canada; vol. 2, pp. 247-250.
- Tsapatsoulis, N., et al., "Face Detection in Color Images and Video Sequences," 10th Mediterranean Electrotechnical Conference (MELECON), May 29-31, 2000; vol. 2; pp. 498-502.
- Wang, Hualu, et al., "A Highly Efficient System for Automatic Face Region Detection in MPEG Video," IEEE Transactions on Circuits and Systems for Video Technology; vol. 7 Issue 4; 1977 pp. 615-628.
- Westerink, P.H., et al., "Two-pass MPEG-2 variable-bitrate encoding," IBM Journal of Research and Development, Jul. 1991, vol. 43, No. 4; <http://citeseerx.ist.psu.edu/viewdoc/summary?doi=10.1.1.128.421>; 18 pages.
- Wiegand, T., et al., "Efficient mode selection for block-based motion compensated video coding," Proceedings, 2005 International Conference on Image Processing IIP 2005, pp. 2559-2562; citeseer.ist.psu.edu/wiegand95efficient.html.
- Wiegand, T., et al., "Rate-distortion optimized mode selection for very low bit rate video coding and the emerging H.263 standard," IEEE Trans. Circuits Syst. Video Technol., Apr. 1996, vol. 6, No. 2, pp. 182-190.
- Wi-Fi Protected Setup, from Wikipedia, Sep. 2, 2010, 3 pages http://en.wikipedia.org/wiki/Wi-Fi_Protected_Setup.
- Wilson, Mark, "Dreamoc 3D Display Turns Any Phone Into Hologram Machine," Oct. 30, 2008; <http://gizmodo.com/5070906/dreamoc-3d-display-turns-any-phone-into-hologram-machine>; 2 pages.
- WirelessDevNet, Melody Launches Bluetooth Over IP, [retrieved and printed on Jun. 5, 2010] <http://www.wirelessdevnet.com/news/2001/155/news5.html>; 2 pages.
- Xia, F., et al., "Home Agent Initiated Flow Binding for Mobile IPv6," Network Working Group, Oct. 19, 2009, 15 pages; <http://tools.ietf.org/html/draft-xia-mext-ha-init-flow-binding-01.txt>.
- Xin, Jun, et al., "Efficient macroblock coding-mode decision for H.264/AVC video coding," Technical Report MERL 2004-079, Mitsubishi Electric Research Laboratories, Jan. 2004; www.merl.com/publications/TR2004-079/; 12 pages.
- Yang, Jie, et al., "A Real-Time Face Tracker," Proceedings 3rd IEEE Workshop on Applications of Computer Vision; 1996; Dec. 2-4, 1996; pp. 142-147; http://www.ri.cmu.edu/pub_files/pub1/yang_jie_1996_1/yang_jie_1996_1.pdf.
- Yang, Ming-Hsuan, et al., "Detecting Faces in Images: A Survey," vol. 24, No. 1; Jan. 2002; pp. 34-58; <http://vision.ai.uiuc.edu/mhyang/papers/pami02a.pdf>.
- Yang, Ruigang, et al., "Real-Time Consensus-Based Scene Reconstruction using Commodity Graphics Hardware," Department of Computer Science, University of North Carolina at Chapel Hill; 2002; http://www.cs.unc.edu/Research/stc/publications/yang_pacigra2002.pdf; 10 pages.
- Yang, Xiaokang, et al., Rate Control for H.264 with Two-Step Quantization Parameter Determination but Single-Pass Encoding, EURASIP Journal on Applied Signal Processing, Jun. 2006; <http://downloads.hindawi.com/journals/asp/2006/063409.pdf>; 13 pages.
- Yegani, P. et al., "GRE Key Extension for Mobile IPv4," Network Working Group, Feb. 2006, 11 pages; <http://tools.ietf.org/pdf/draft-yegani-gre-key-extension-01.pdf>.
- Yoo, Byoung-hun, et al., "Image-Based Modeling of Urban Buildings Using Aerial Photographs and Digital Maps," Transactions in GIS, 2006, 10(3): pp. 377-394.
- Zhong, Ren, et al., "Integration of Mobile IP and MPLS," Network Working Group, Jul. 2000, 15 pages; <http://tools.ietf.org/html/draft-zhong-mobile-ip-mpls-01>.
- U.S. Appl. No. 29/375,624, filed Sep. 24, 2010, entitled "Mounted Video Unit," Inventor(s): Ashok T. Desai et al.
- U.S. Appl. No. 29/375,627, filed Sep. 24, 2010, entitled "Mounted Video Unit," Inventor(s): Ashok T. Desai et al.
- U.S. Appl. No. 29/369,951, filed Sep. 15, 2010, entitled "Video Unit With Integrated Features," Inventor(s): Kyle A. Buzzard et al.
- U.S. Appl. No. 29/375,458, filed Sep. 22, 2010, entitled "Video Unit With Integrated Features," Inventor(s): Kyle A. Buzzard et al.

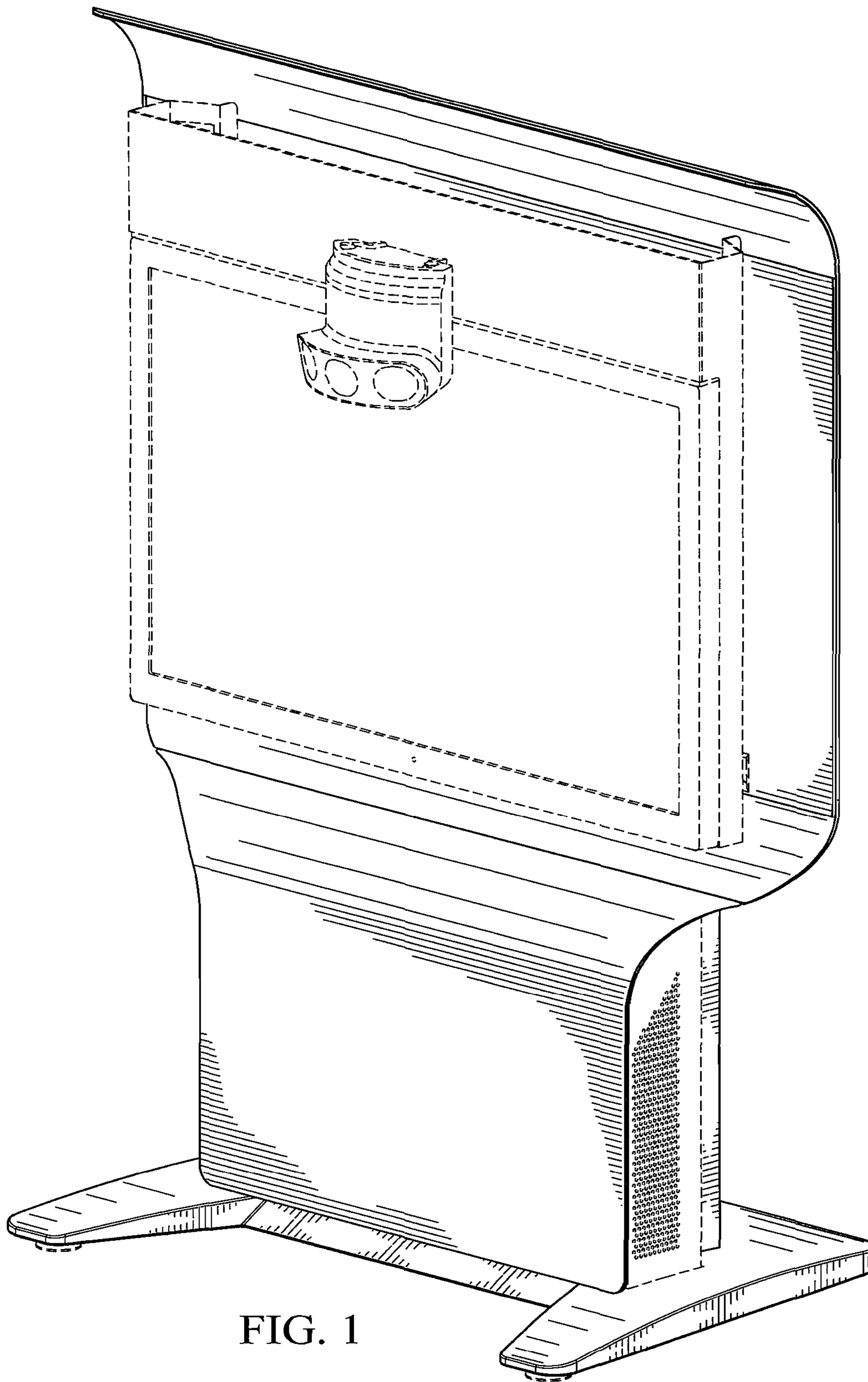

FIG. 1

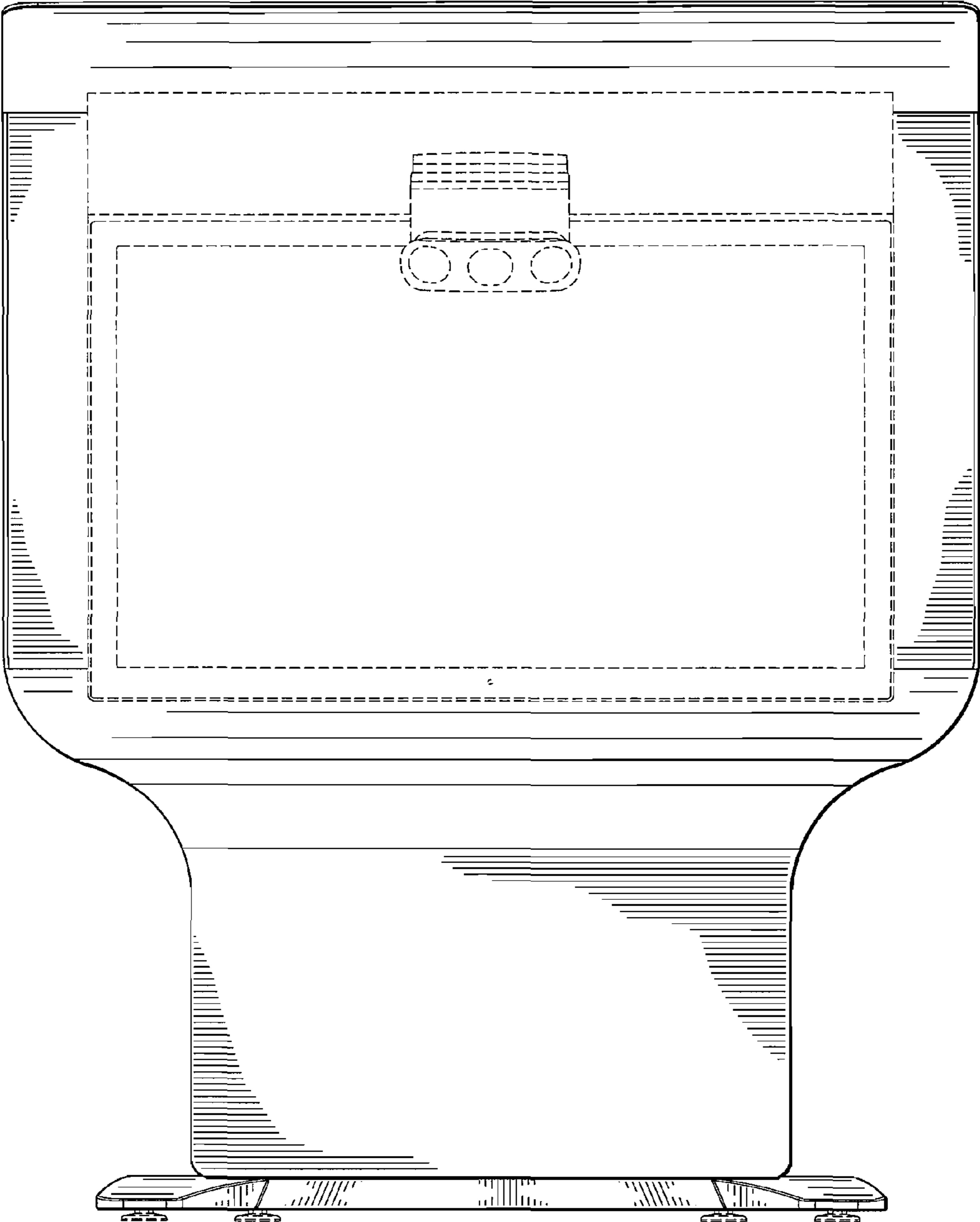

FIG. 2

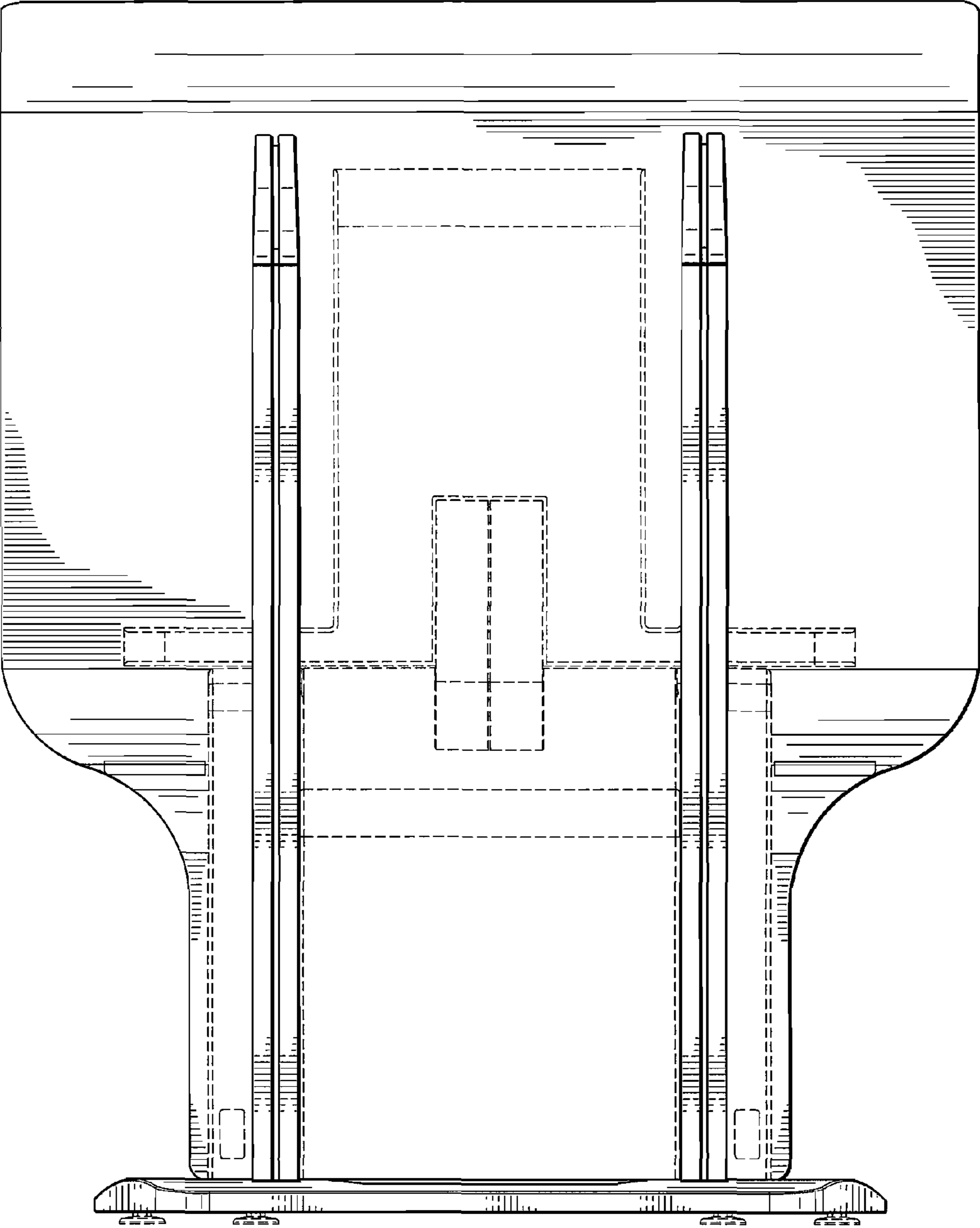

FIG. 3

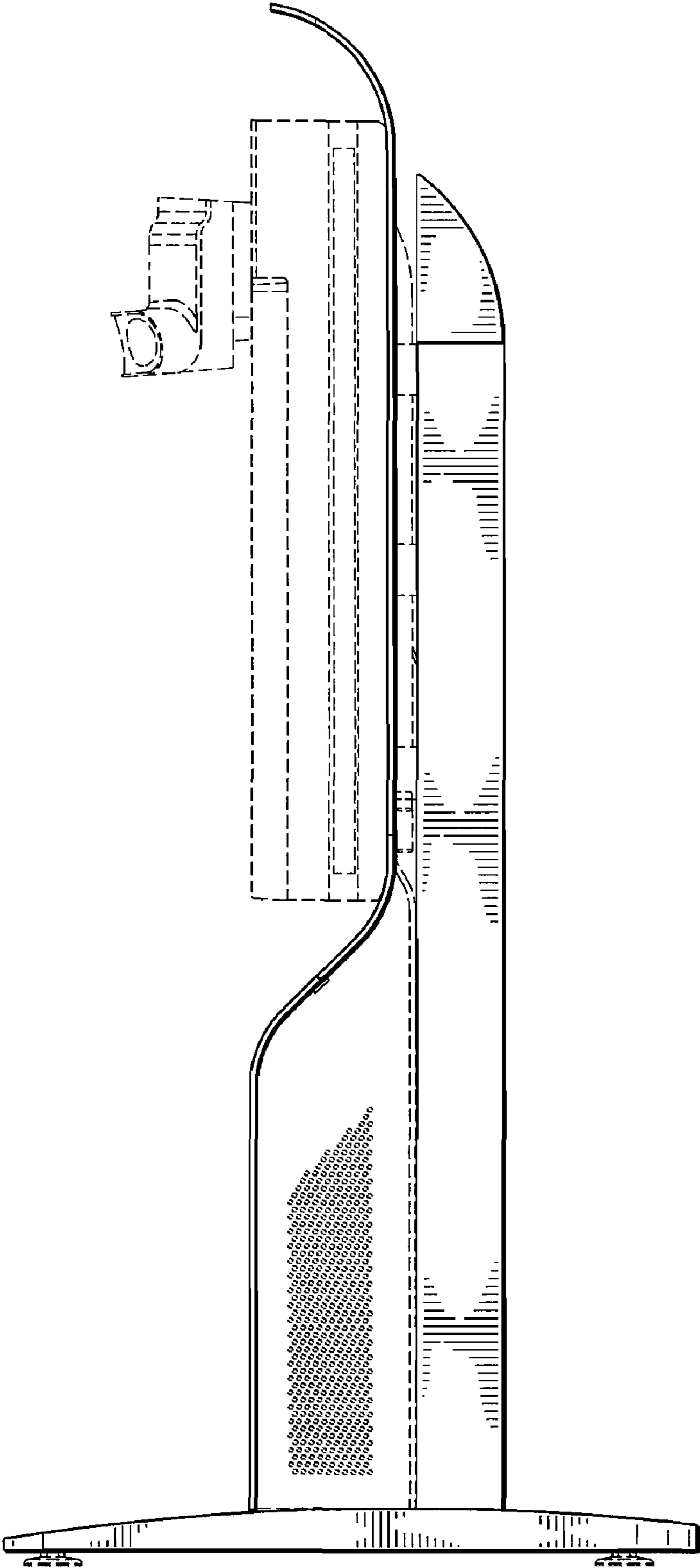

FIG. 4

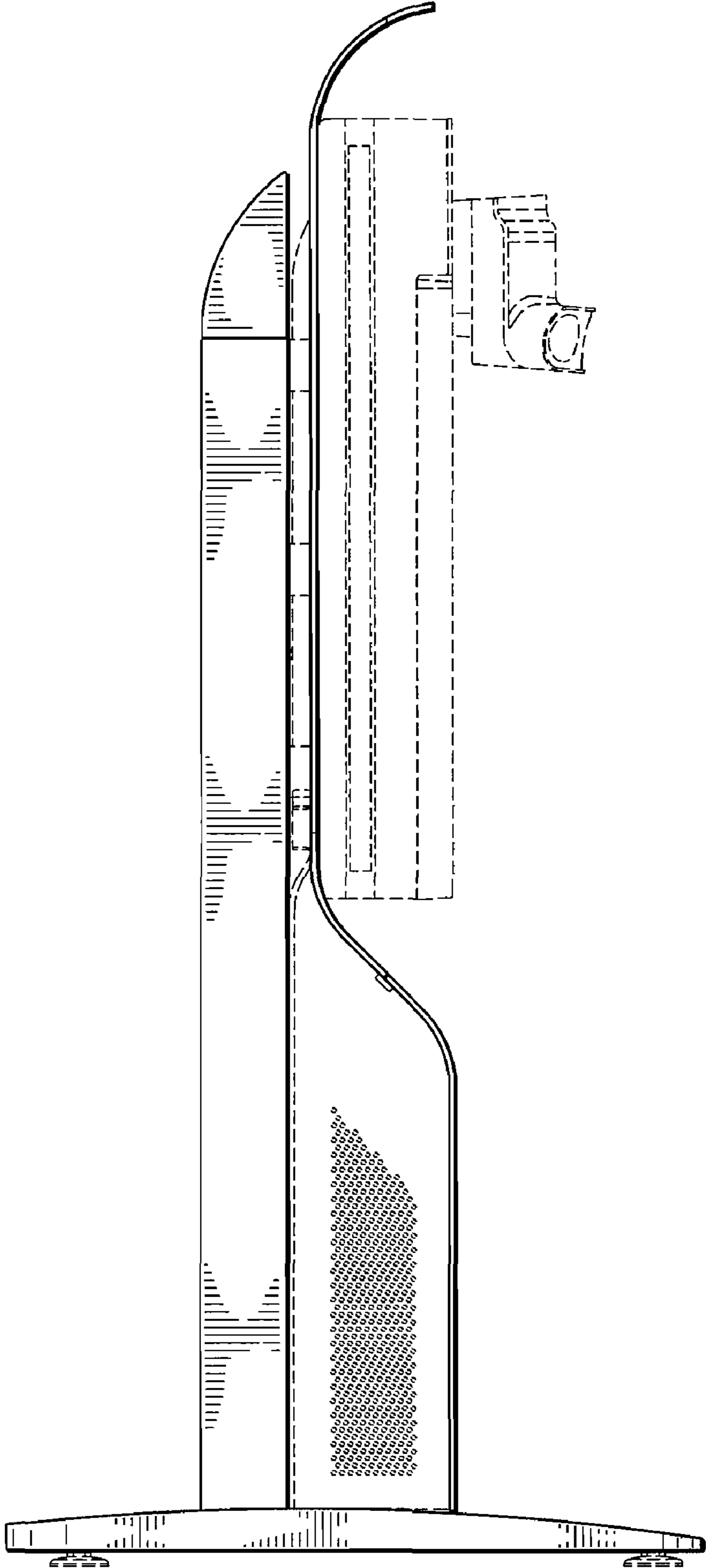

FIG. 5

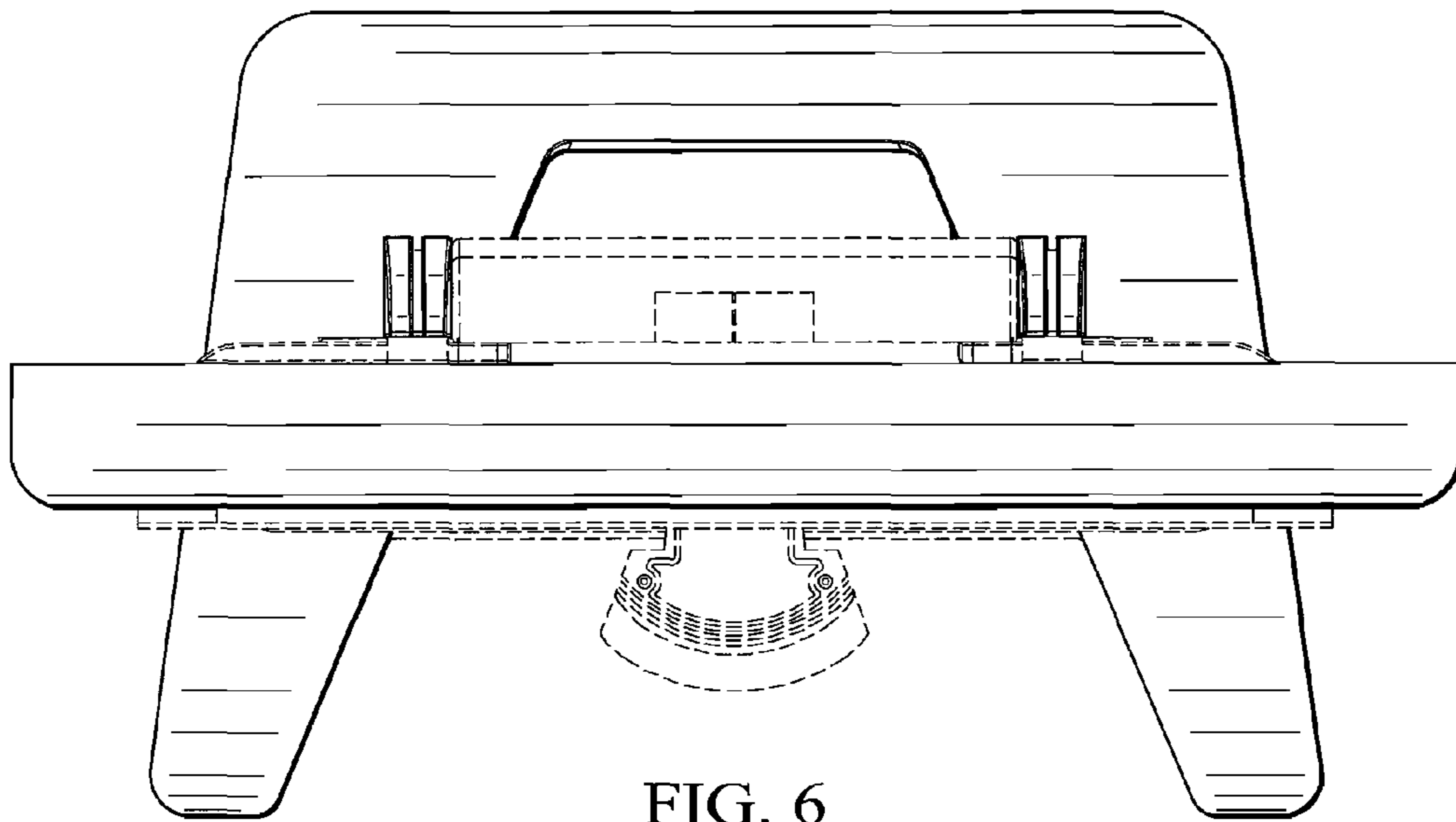

FIG. 6

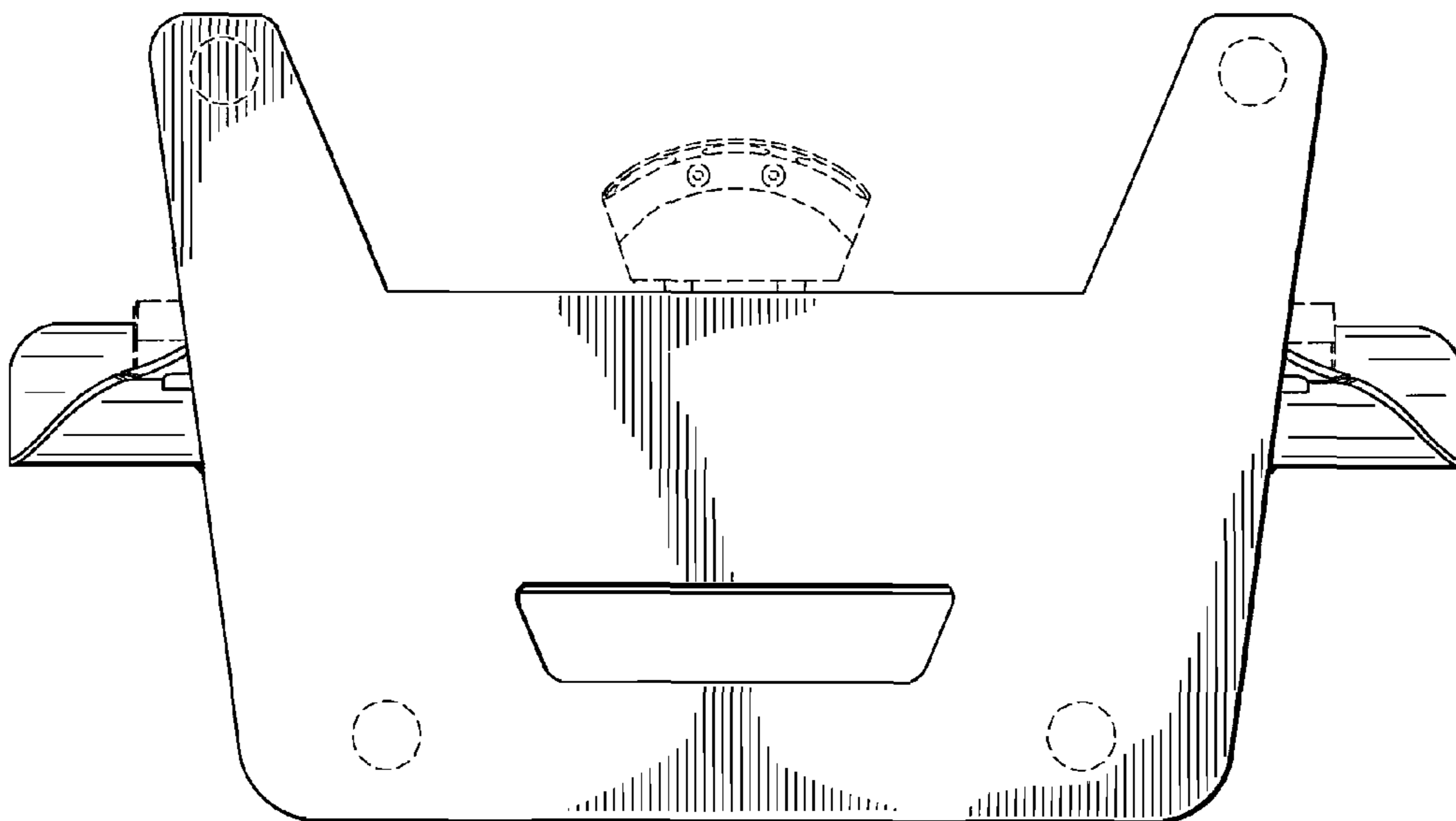

FIG. 7

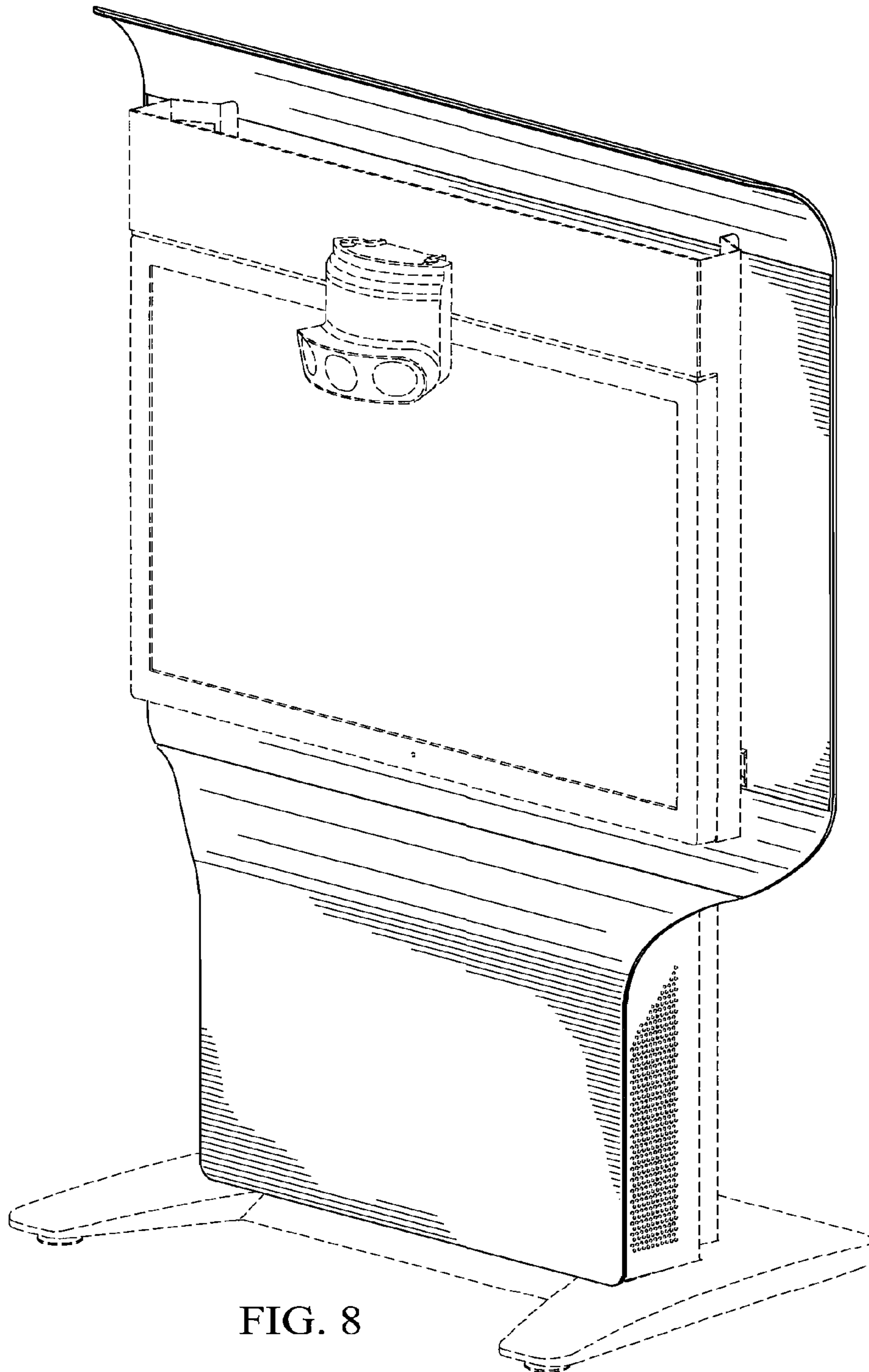

FIG. 8

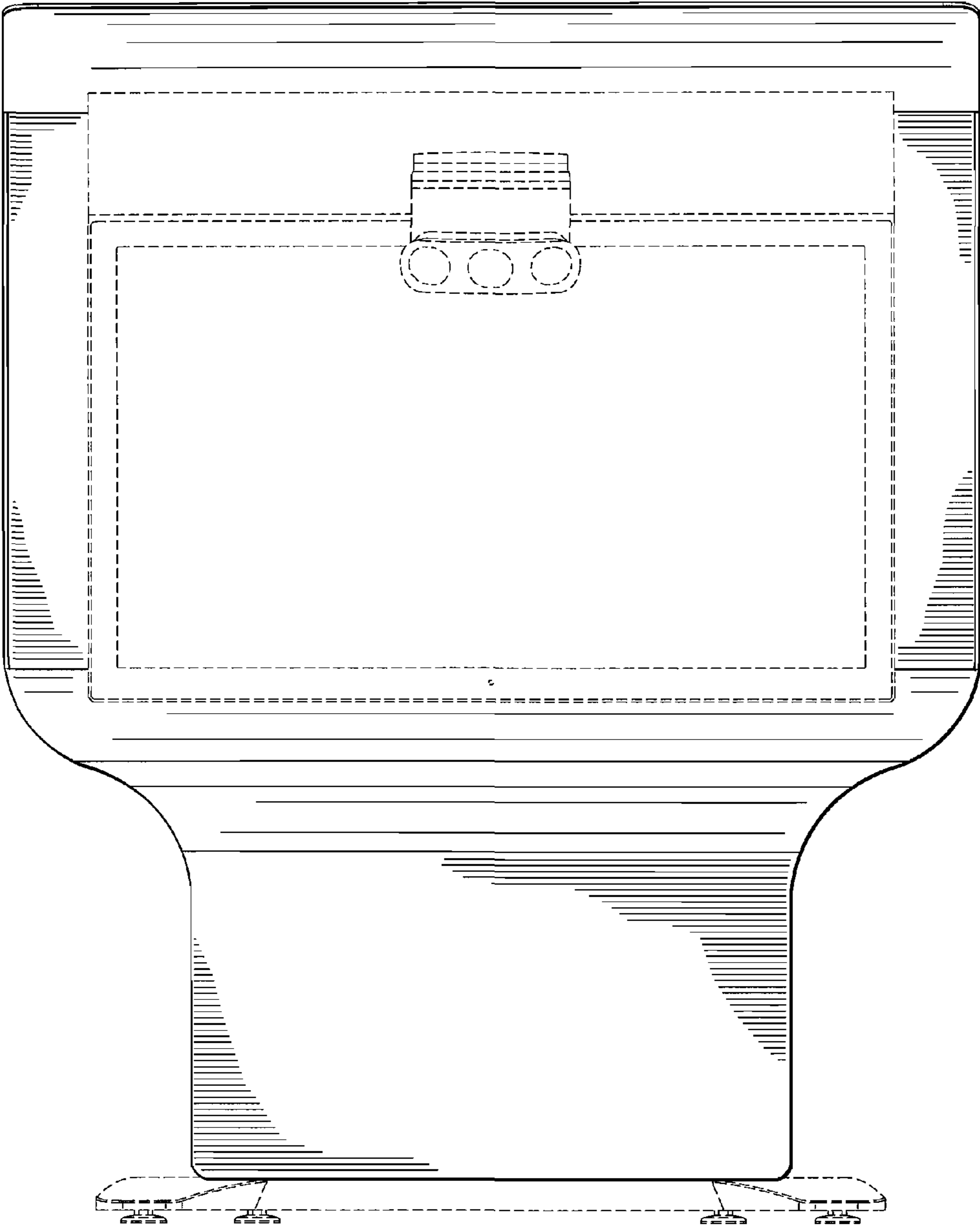

FIG. 9

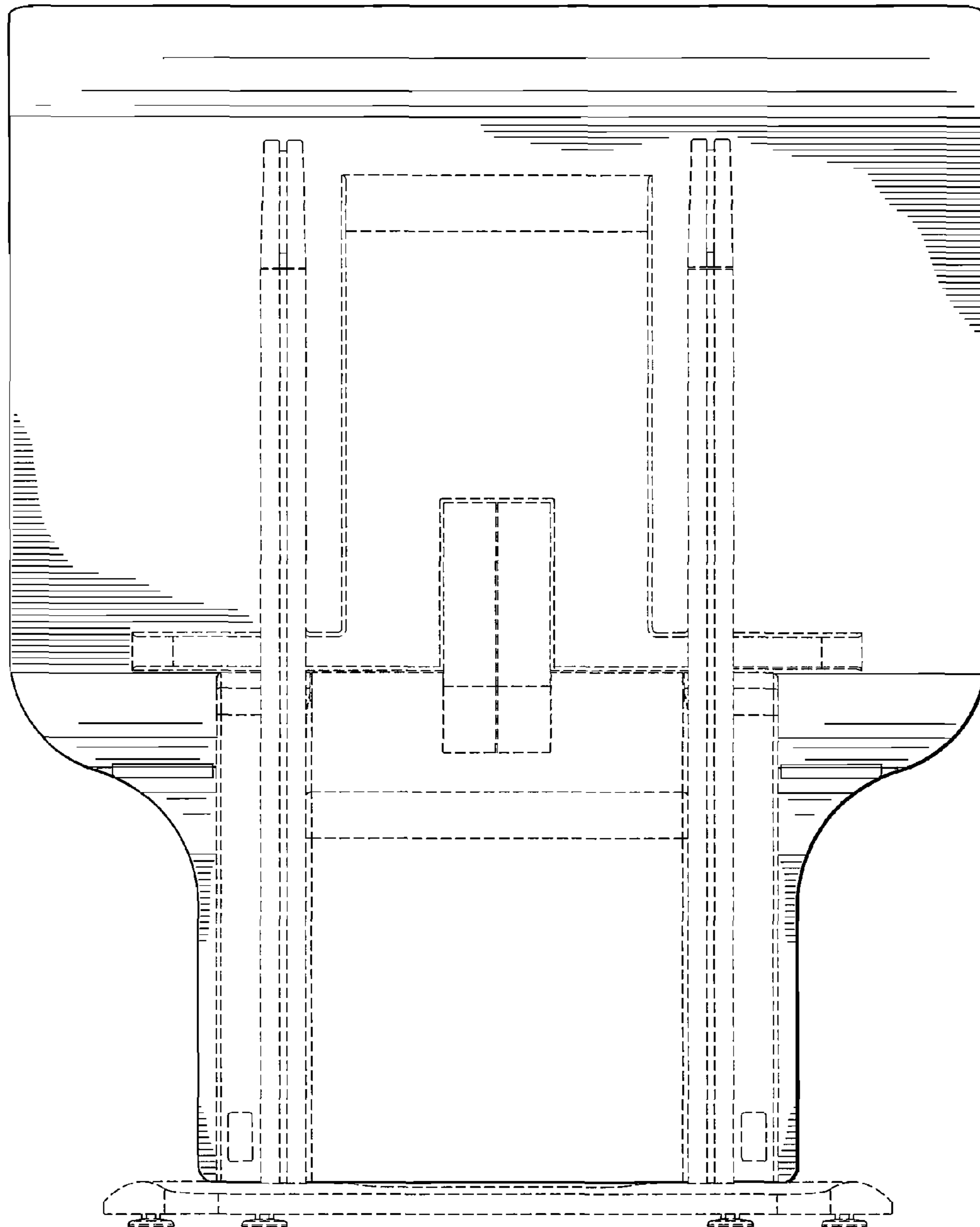

FIG. 10

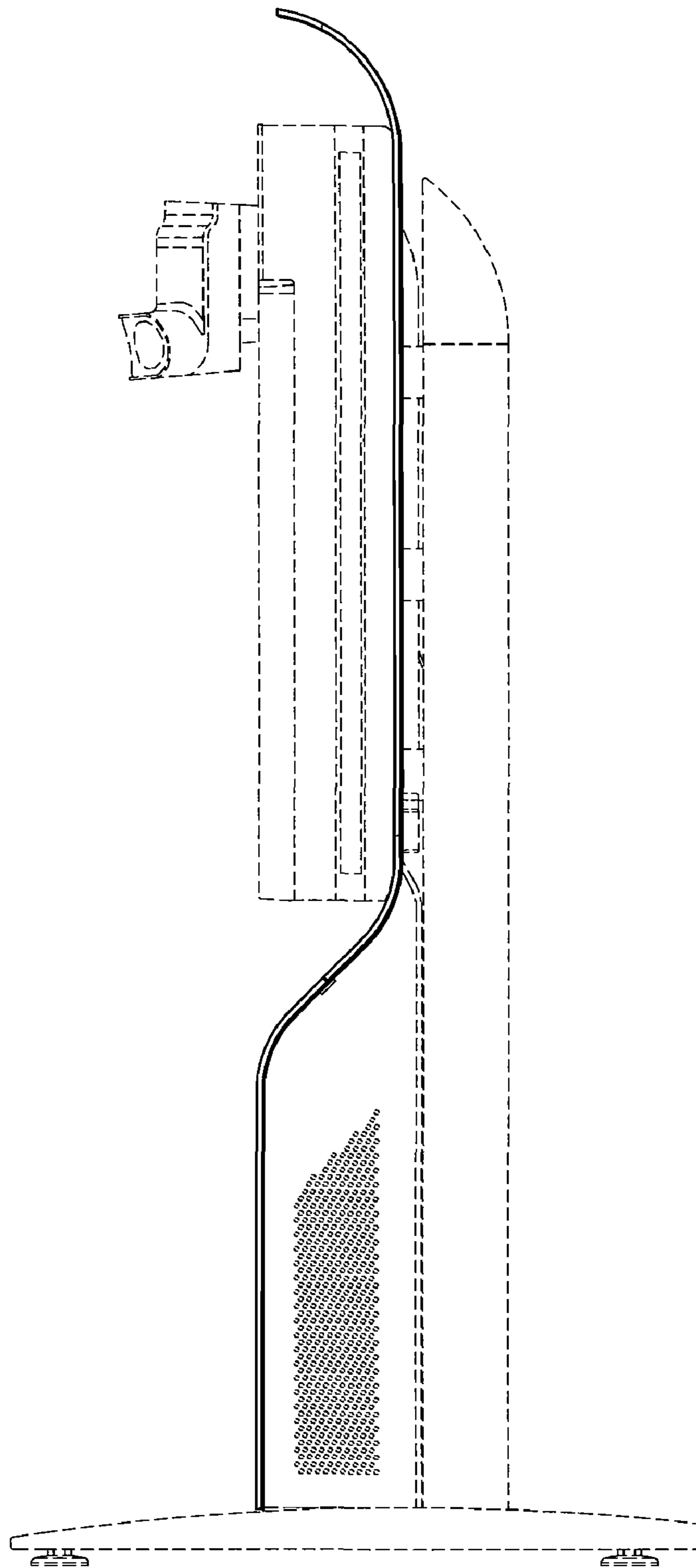

FIG. 11

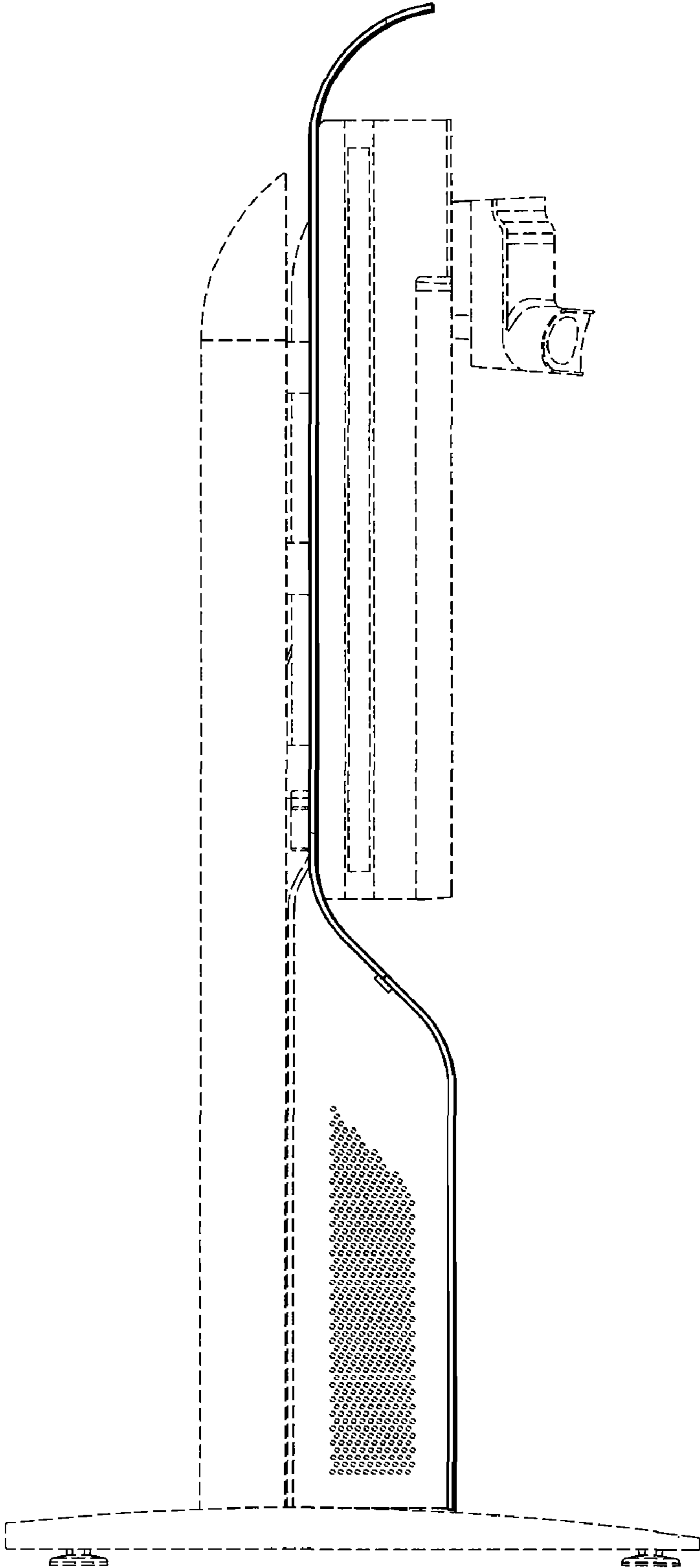

FIG. 12

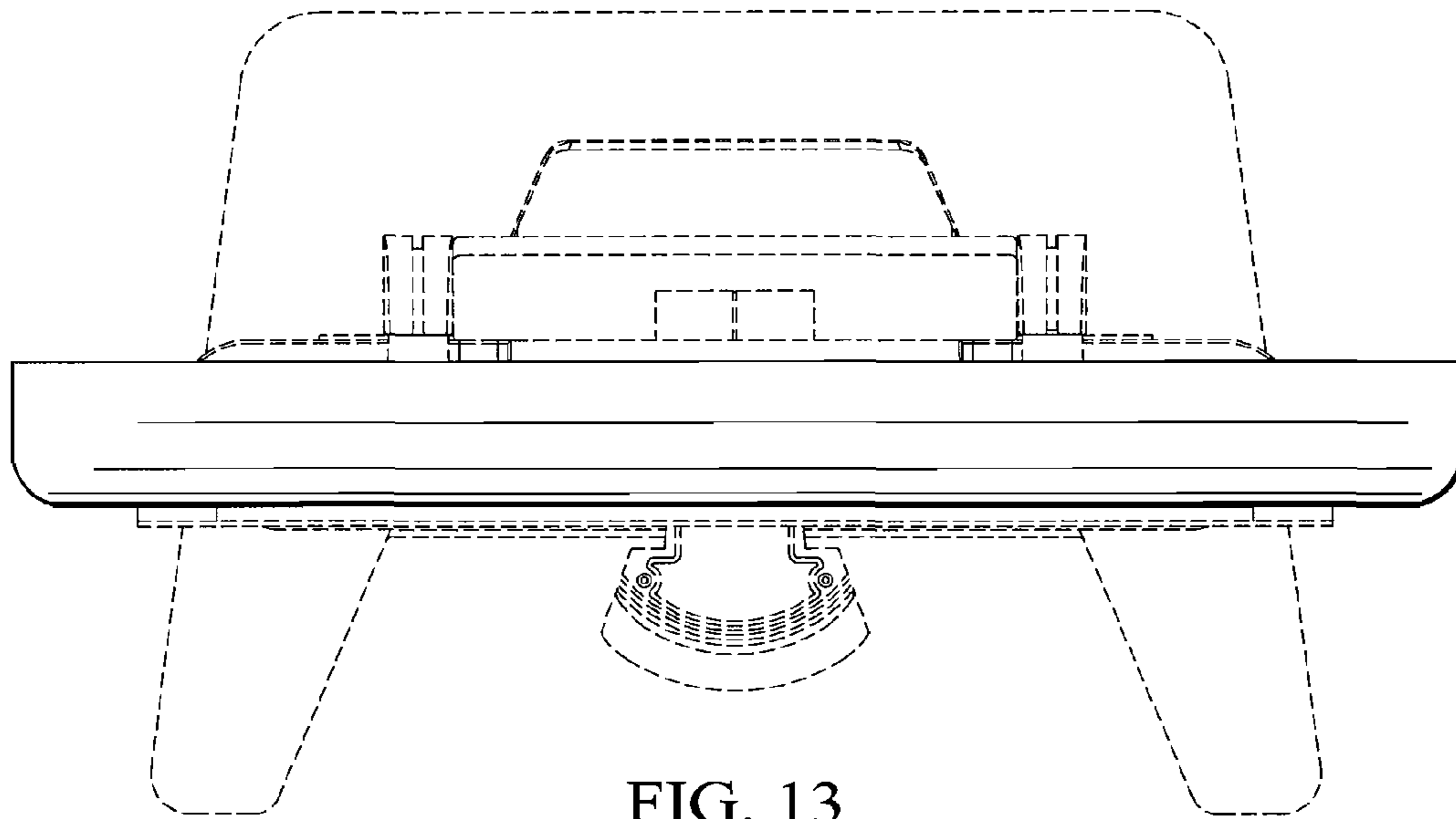

FIG. 13

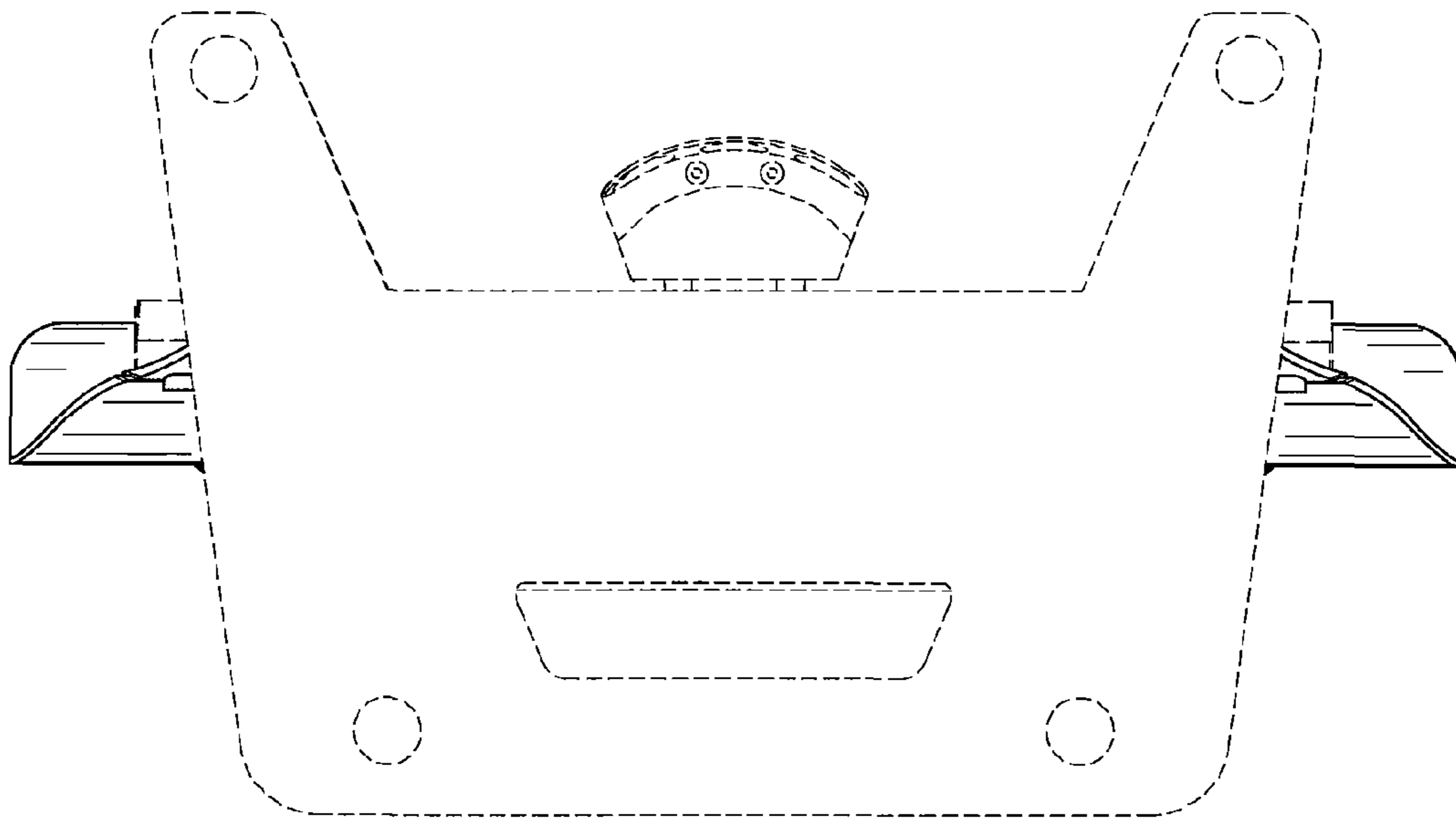

FIG. 14