



US00D637551S

(12) **United States Design Patent**
Tournier

(10) **Patent No.:** **US D637,551 S**

(45) **Date of Patent:** **** May 10, 2011**

(54) **VALVE CAP**

(75) Inventor: **Damien Tournier**, Bulle (FR)

(73) Assignee: **Schrader-Bridgeport International, Inc.**, Alta Vista, VA (US)

(**) Term: **14 Years**

(21) Appl. No.: **29/349,482**

(22) Filed: **Apr. 7, 2010**

(51) **LOC (9) Cl.** **12-15**

(52) **U.S. Cl.** **D12/607**

(58) **Field of Classification Search** D12/606-607;
D8/310; D9/300, 450, 445-446, 453; 152/427-429,
152/DIG. 7; 280/159, 847; D23/260; 74/558.5;
137/232; 139/89.1-89.4

See application file for complete search history.

D405,743 S	2/1999	Hussaini	D12/153
D443,235 S *	6/2001	Hsu	D12/607
D445,734 S *	7/2001	Sheu	D12/607
D449,259 S *	10/2001	Sheu	D12/607
D457,432 S *	5/2002	Peabody	D9/453
D461,127 S *	8/2002	Peabody	D9/453
D496,627 S	9/2004	Nikolayev et al.	D12/606
D624,010 S *	9/2010	Tournier	D12/606
D624,875 S *	10/2010	Cowles	D12/607
D627,294 S *	11/2010	Cowles	D12/607

* cited by examiner

Primary Examiner — Stacia Cadmus

(74) *Attorney, Agent, or Firm* — J. A. Thurnau, Esq.; T. A. Dougherty, Esq.; P. N. Dunlap, Esq.

(57) **CLAIM**

The ornamental design for a valve cap, as shown and described.

DESCRIPTION

FIG. 1 is a side elevation view.

FIG. 2 is a top plan view.

FIG. 3 is a bottom plan view.

FIG. 4 is a cross-section view taken along line 4—4 in FIG. 2; and,

FIG. 5 is a perspective view.

The broken line showing of the valve cap is for the purpose of illustrating gripping ridges and forms no part of the claimed design.

1 Claim, 1 Drawing Sheet

(56) **References Cited**

U.S. PATENT DOCUMENTS

D25,774 S *	7/1896	Schrader	D12/607
D28,585 S *	5/1898	Lines	D12/607
D32,855 S *	6/1900	Schrader	D12/607
D86,154 S *	2/1932	Broecker	D12/607
D169,353 S *	4/1953	Boyer	D12/607
D201,606 S *	7/1965	McCord	D12/607
D216,353 S *	12/1969	Nelson	D12/607
D268,924 S	5/1983	Winther	D12/153
D304,817 S	11/1989	Earley et al.	D12/153
D305,222 S	12/1989	Geib	D12/153

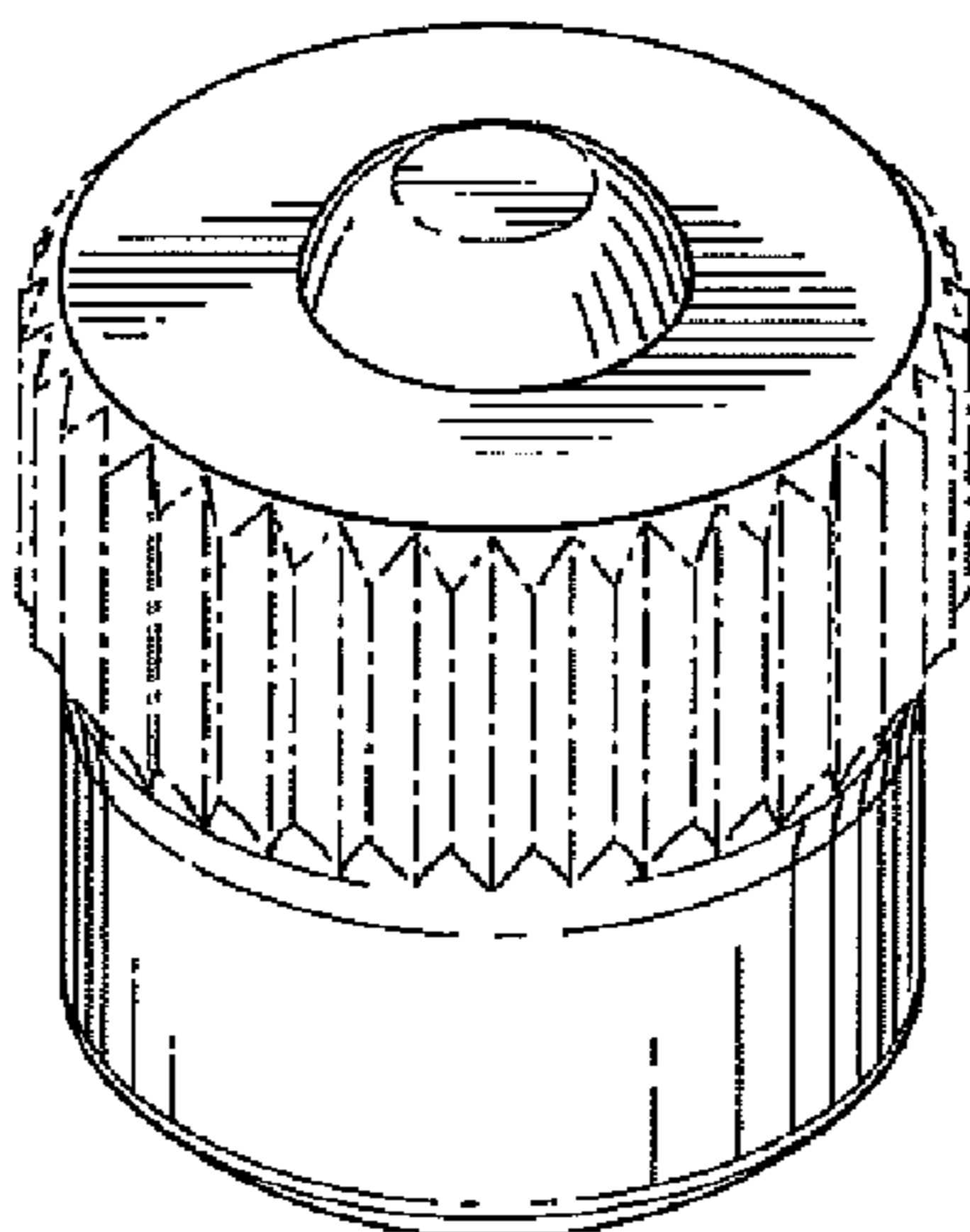
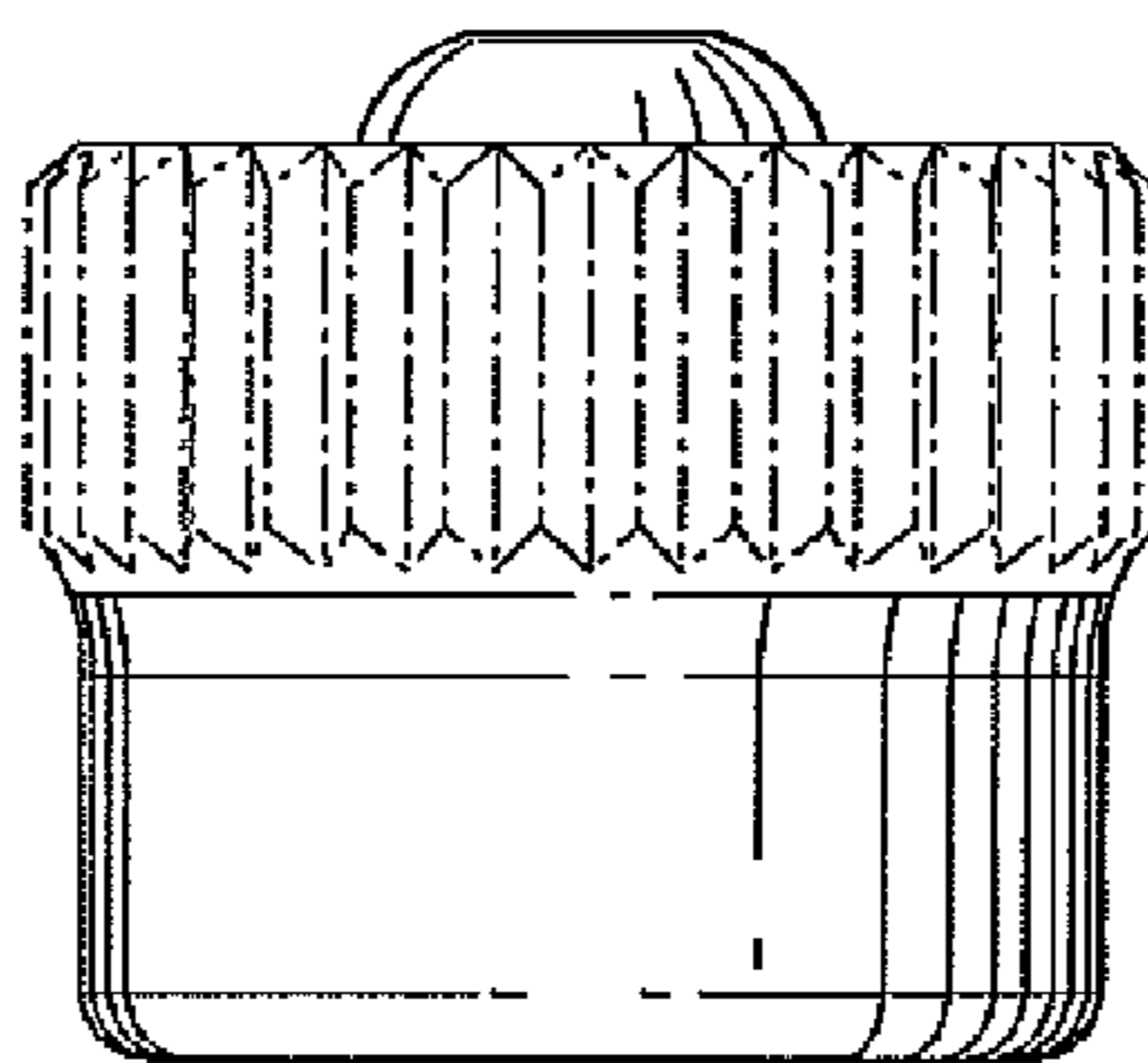

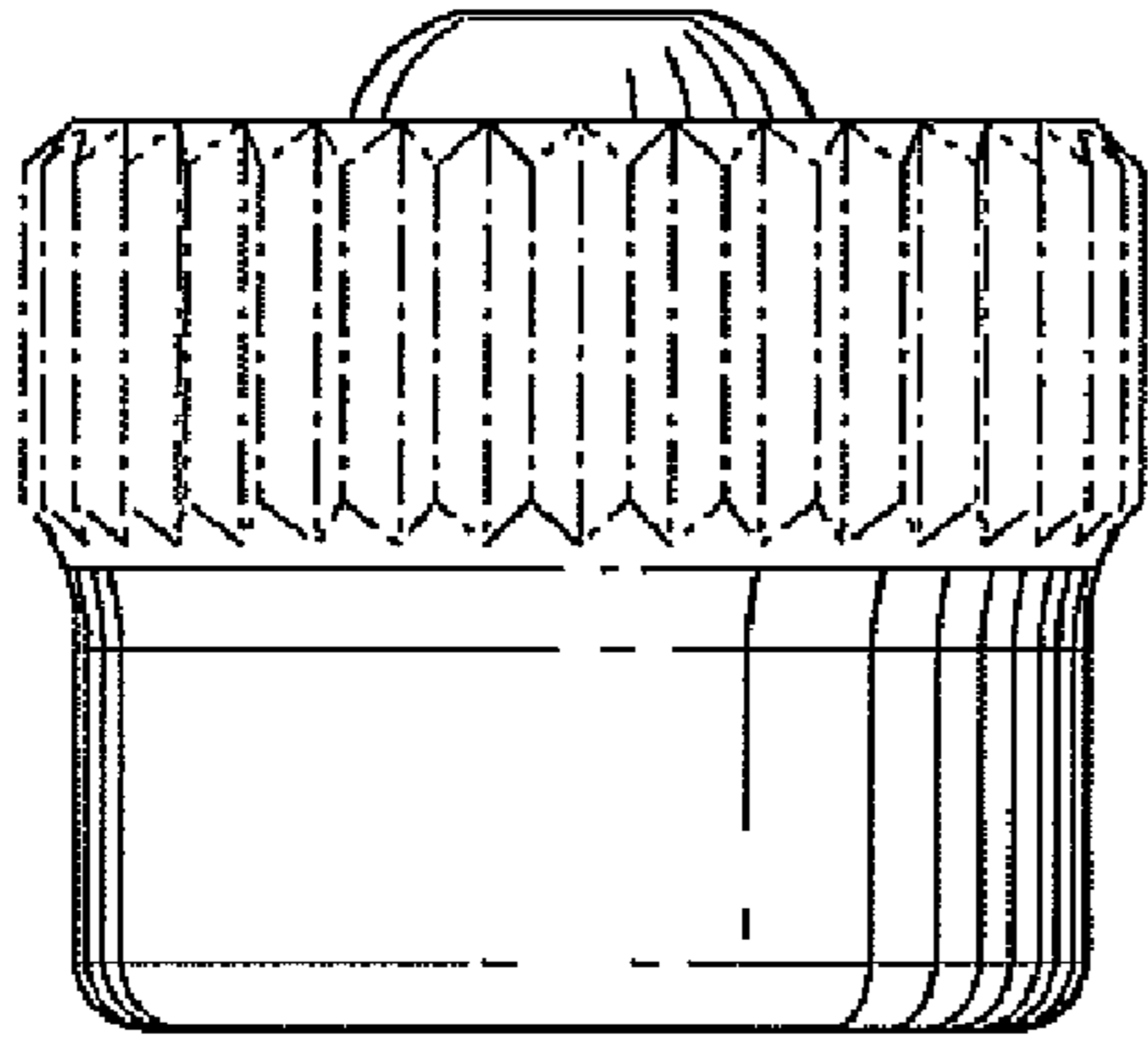

FIG. 1

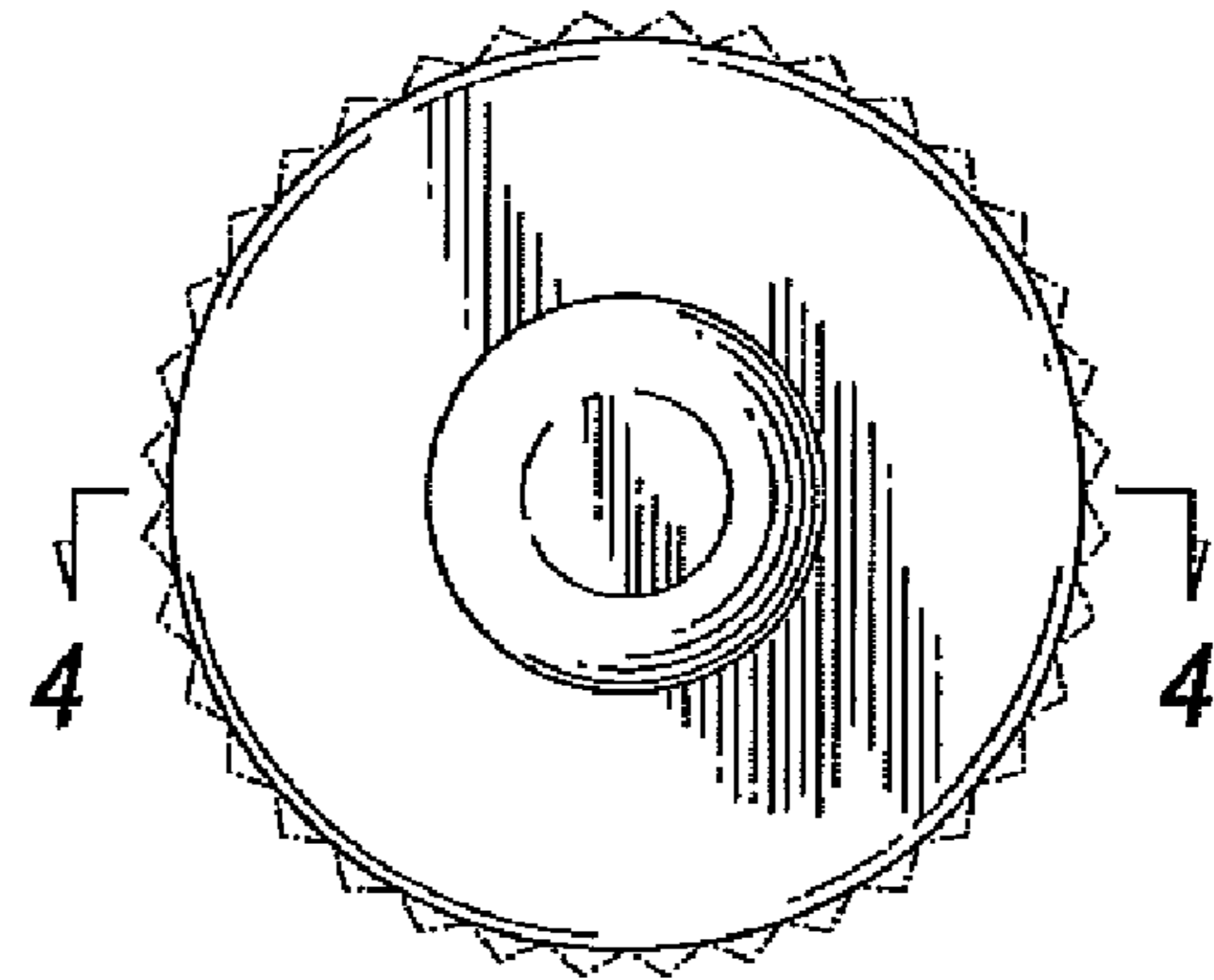

FIG. 2

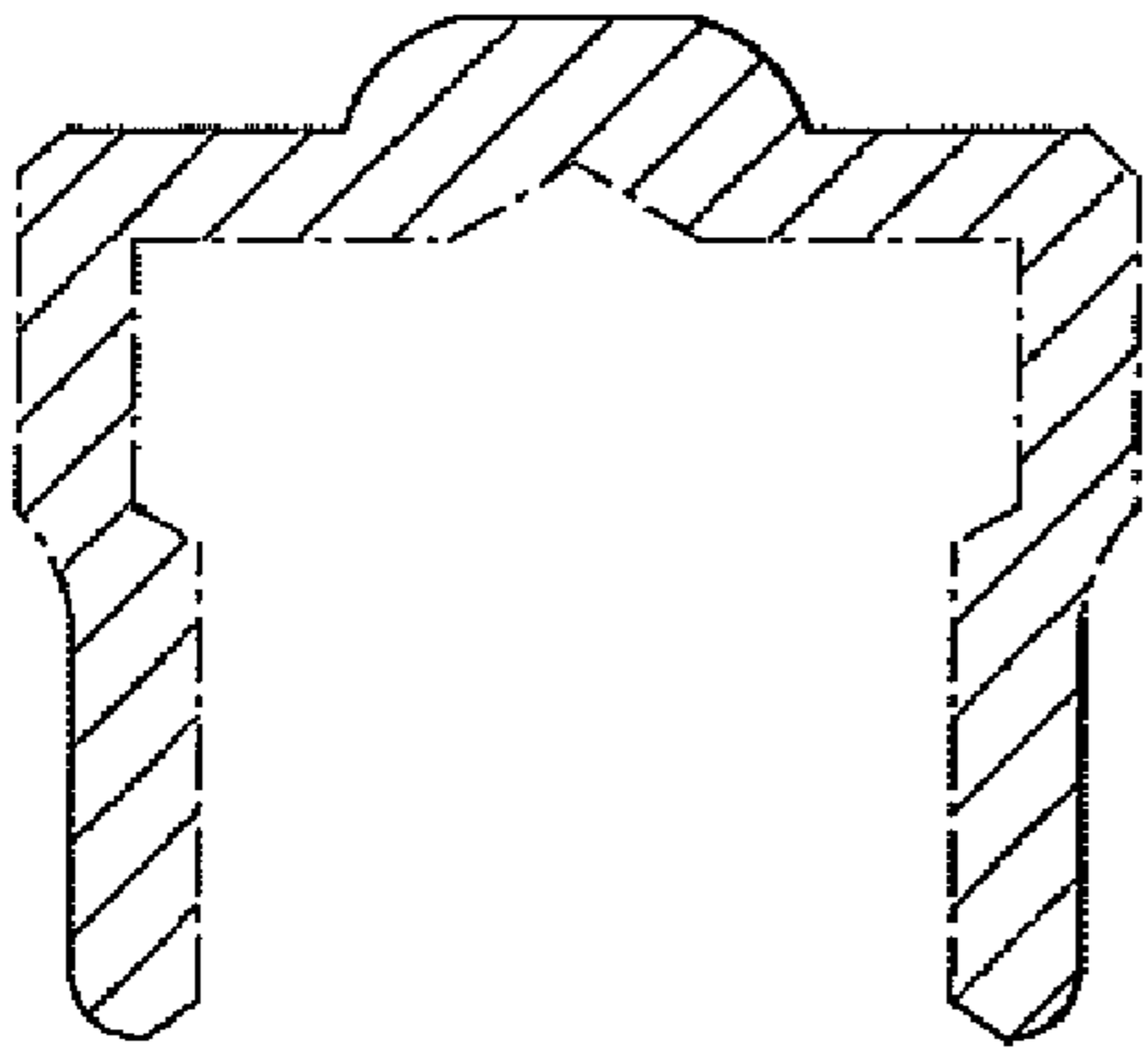

FIG. 4

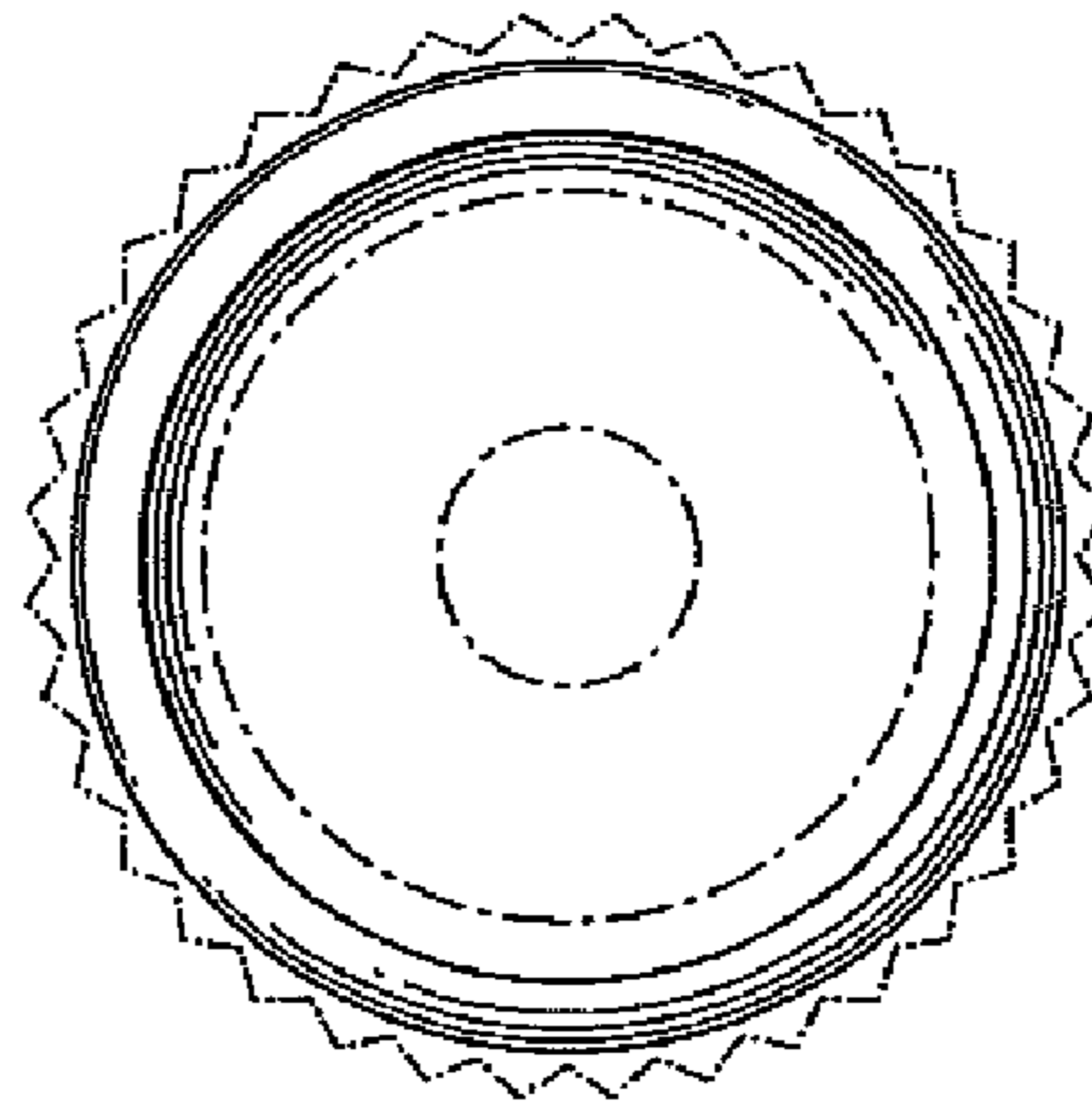

FIG. 3

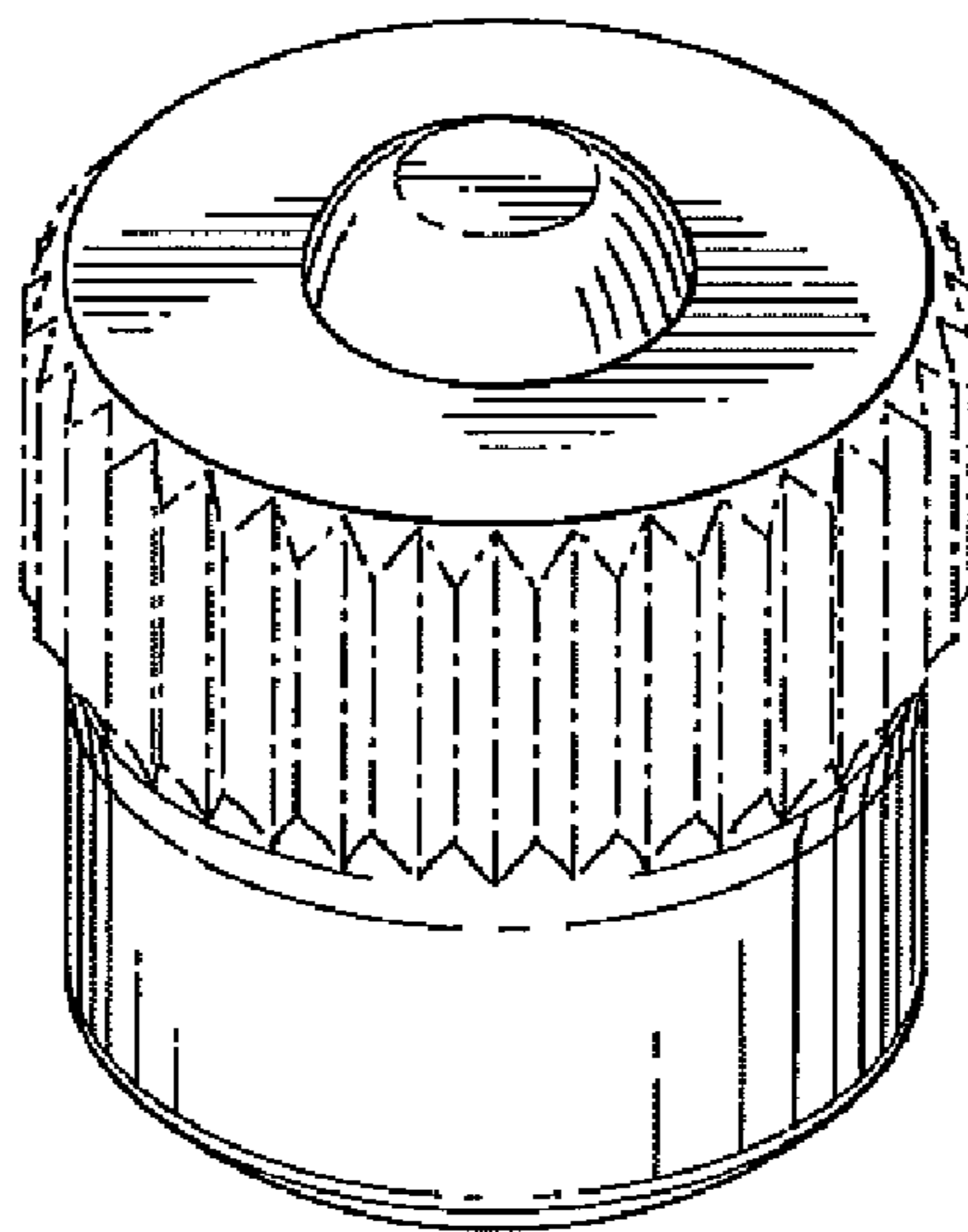

FIG. 5