



US00D637525S

(12) **United States Design Patent**
Sugimoto

(10) **Patent No.:** **US D637,525 S**

(45) **Date of Patent:** **** May 10, 2011**

(54) **MOTORCYCLE**

D597,891 S * 8/2009 Andoh D12/110
D604,204 S 11/2009 Uchiyama
D610,044 S 2/2010 Sugimoto

(75) Inventor: **Hideo Sugimoto**, Hamamatsu (JP)

(73) Assignee: **Suzuki Motor Corporation**,
Shizuoka-Pref (JP)

(**) Term: **14 Years**

(21) Appl. No.: **29/365,218**

(22) Filed: **Jul. 6, 2010**

(51) **LOC (9) Cl.** **12-11**

(52) **U.S. Cl.** **D12/110**

(58) **Field of Classification Search** D12/110;
180/219, 220

See application file for complete search history.

(56) **References Cited**

U.S. PATENT DOCUMENTS

D372,442 S	*	8/1996	Kitagawa et al.	D12/110
D384,601 S		10/1997	Hiruma et al.	
D385,226 S		10/1997	Mogi et al.	
D387,017 S		12/1997	Wakita et al.	
D392,601 S		3/1998	Ban et al.	
D394,027 S		5/1998	Ban et al.	
D395,621 S		6/1998	Nishino	
D419,922 S		2/2000	Yamase et al.	
D439,868 S		4/2001	Sugimoto	
D440,189 S		4/2001	Ban et al.	
D470,799 S		2/2003	Yamaguchi	
D513,481 S		1/2006	Lin	
D522,925 S		6/2006	Nishino	
D523,783 S		6/2006	Sugimoto	
D525,919 S		8/2006	Sugimoto	
D572,629 S		7/2008	Kawagishi	
D581,840 S		12/2008	Ichihara et al.	
D583,714 S		12/2008	Ichihara et al.	
D588,504 S		3/2009	Kawagishi	
D590,302 S		4/2009	Tanaka et al.	

OTHER PUBLICATIONS

Cycle World Oct. 2008, Kawasaki Vulcan 2000 LT on p. 42 and
Suzuki Boulevard C109RT on p. 45.*

Cycle World Nov. 2008, Triumph Thunderbird on p. 35.*

* cited by examiner

Primary Examiner — Susan M Lee

Assistant Examiner — Linda Brooks

(74) *Attorney, Agent, or Firm* — Lando & Anastasi, LLP

(57) **CLAIM**

The ornamental design for a motorcycle, as shown and
described.

DESCRIPTION

FIG. 1 is a front elevational view of the motorcycle according
to my new design.

FIG. 2 is a rear elevational view.

FIG. 3 is a top plan view.

FIG. 4 is a left side elevational view of the motorcycle of FIG.
1.

FIG. 5 is a right side elevational view.

FIG. 6 is a front perspective view as seen from the left side of
FIG. 1.

FIG. 7 is a rear perspective view as seen from the left side of
FIG. 1.

FIG. 8 is a front perspective view as seen from the left side of
FIG. 1; and,

FIG. 9 is a rear perspective view as seen from the right side of
FIG. 1.

The broken lines show portions of the motorcycle that form
no part of the claimed design.

1 Claim, 8 Drawing Sheets

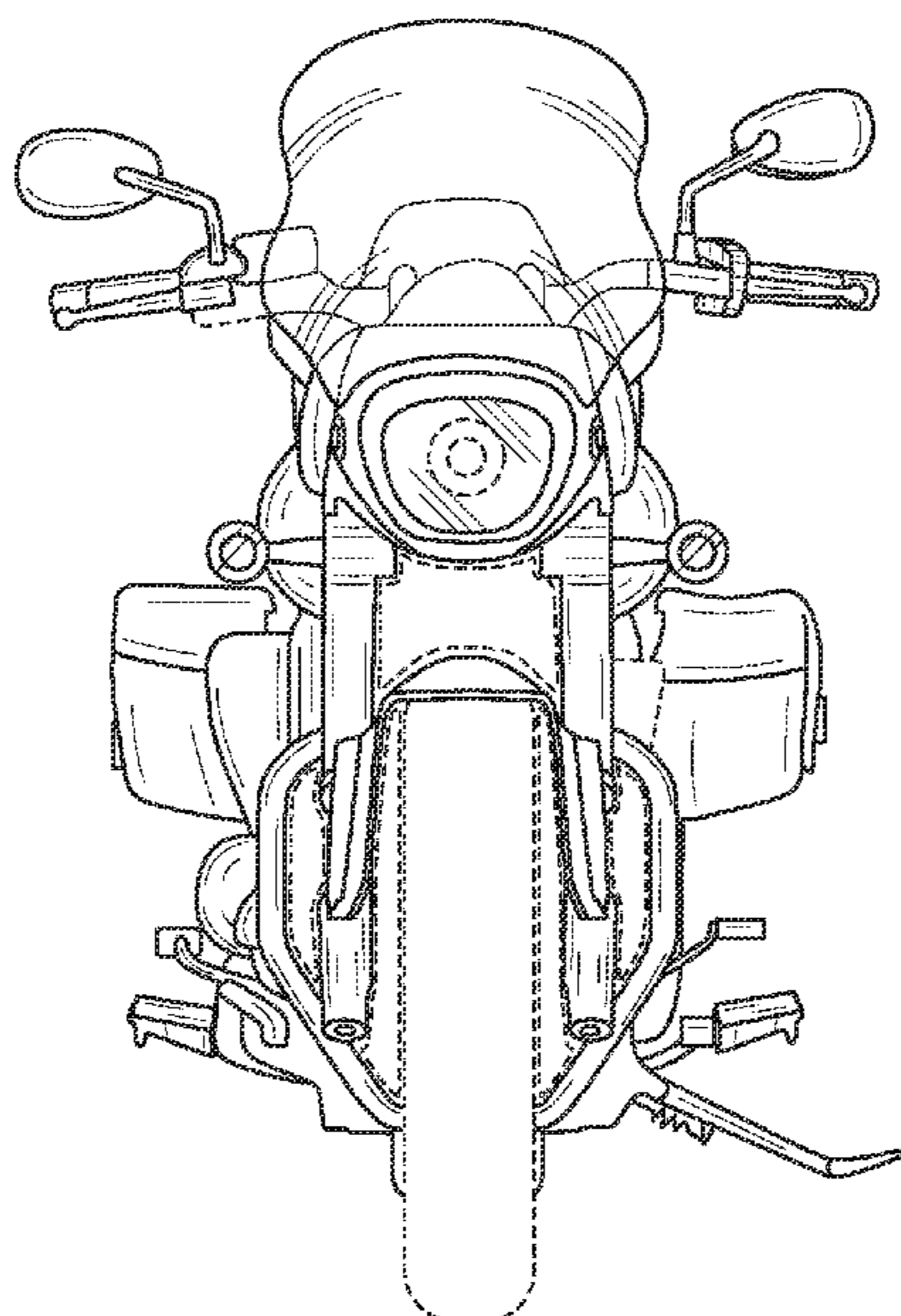

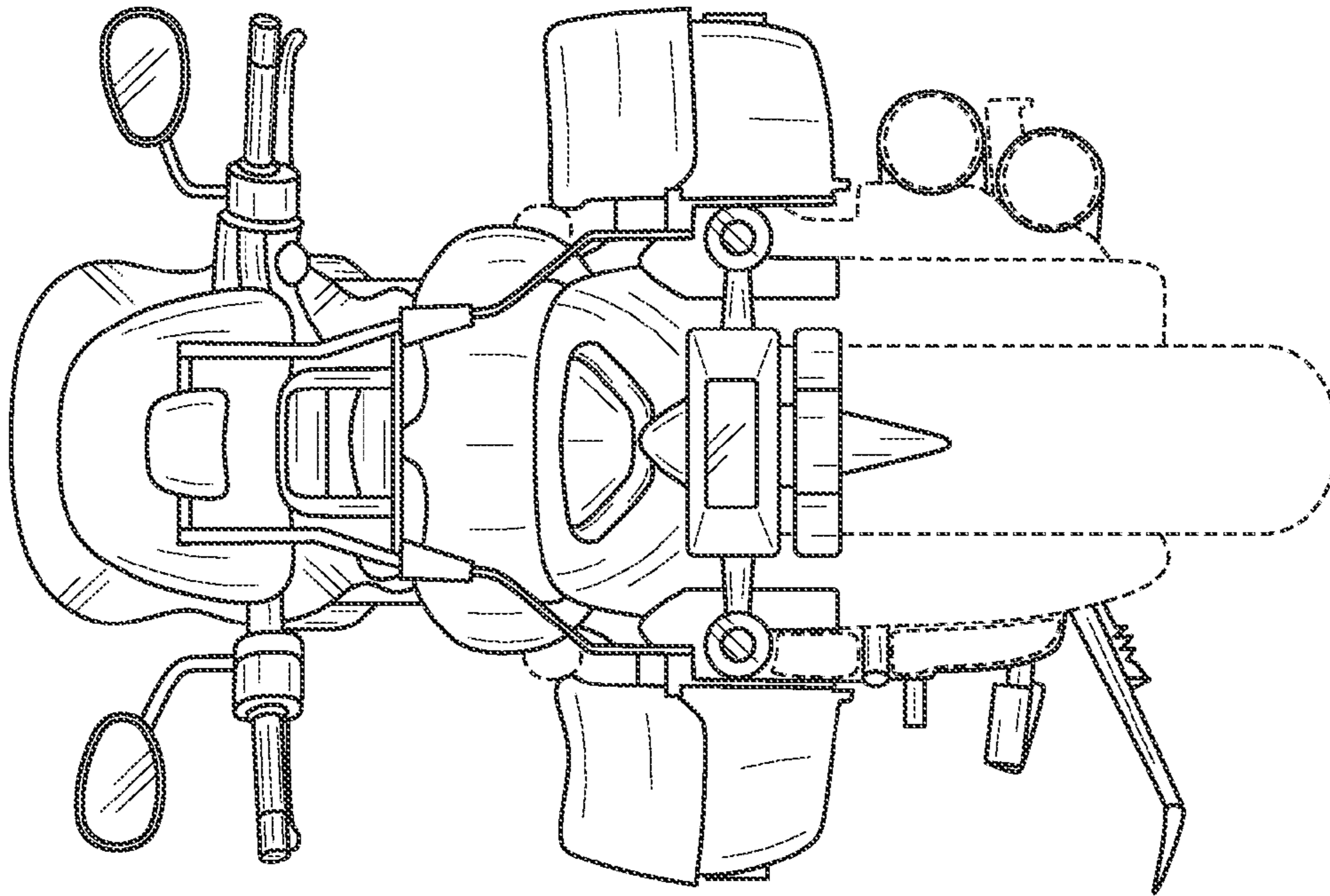

FIG. 2

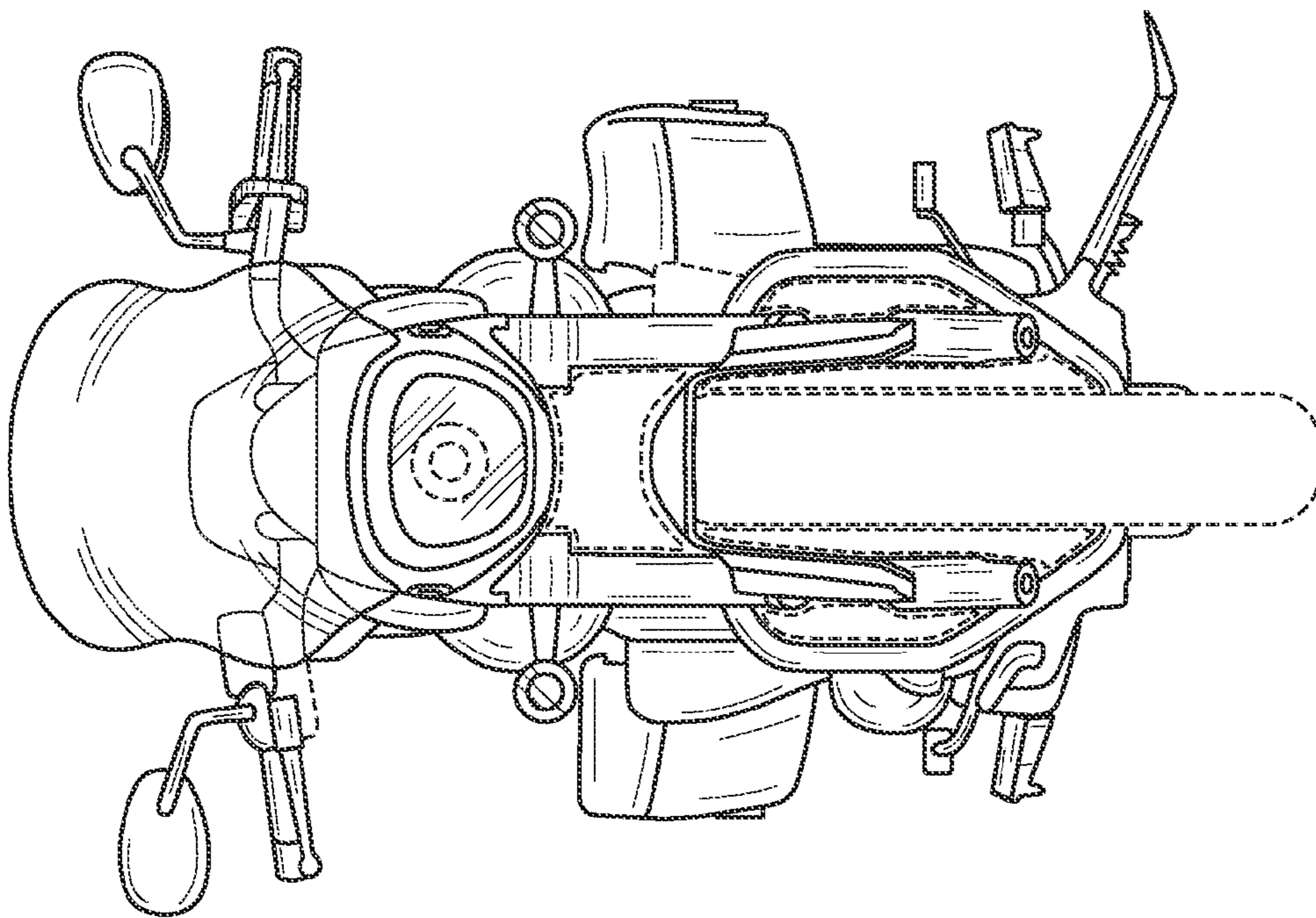

FIG. 1

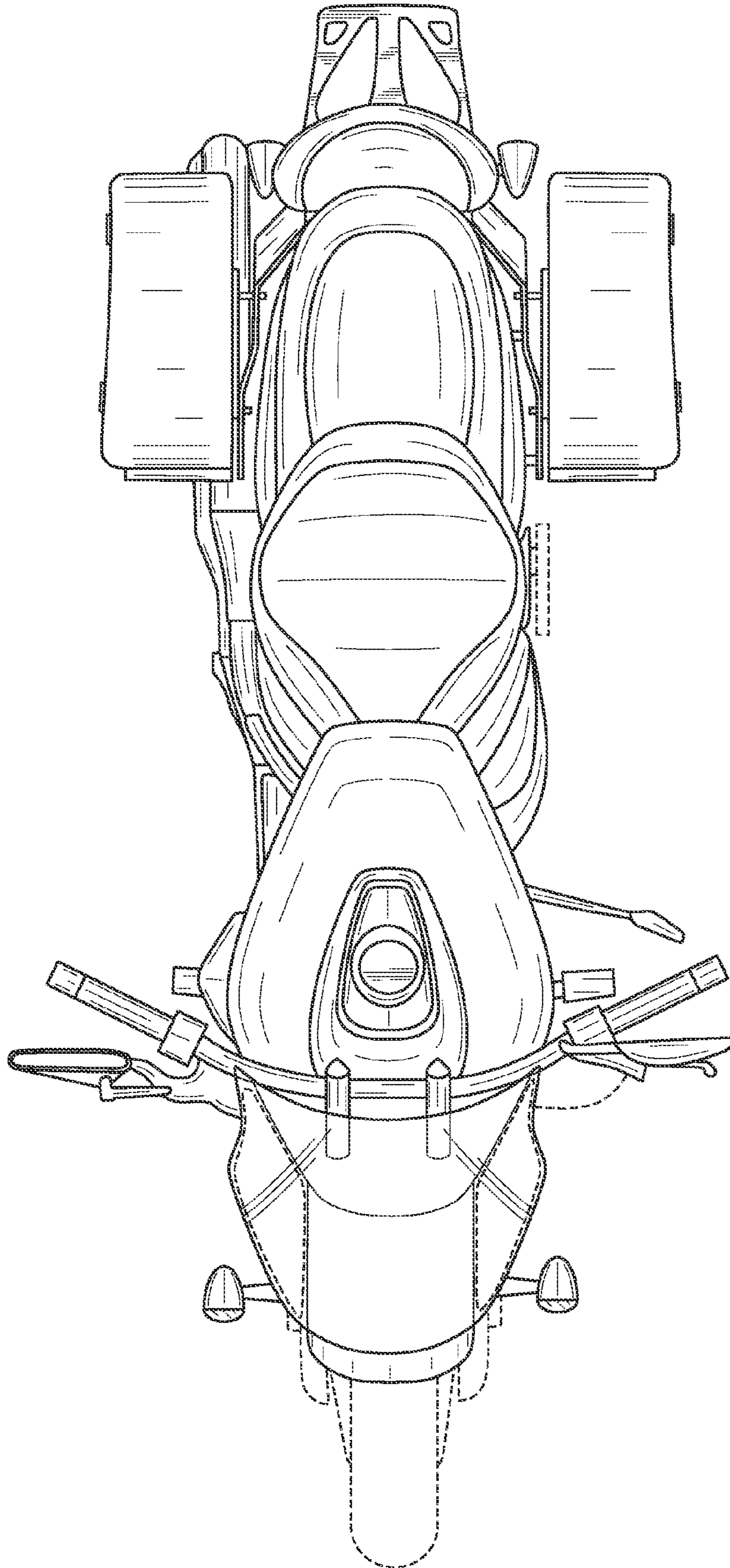

FIG. 3

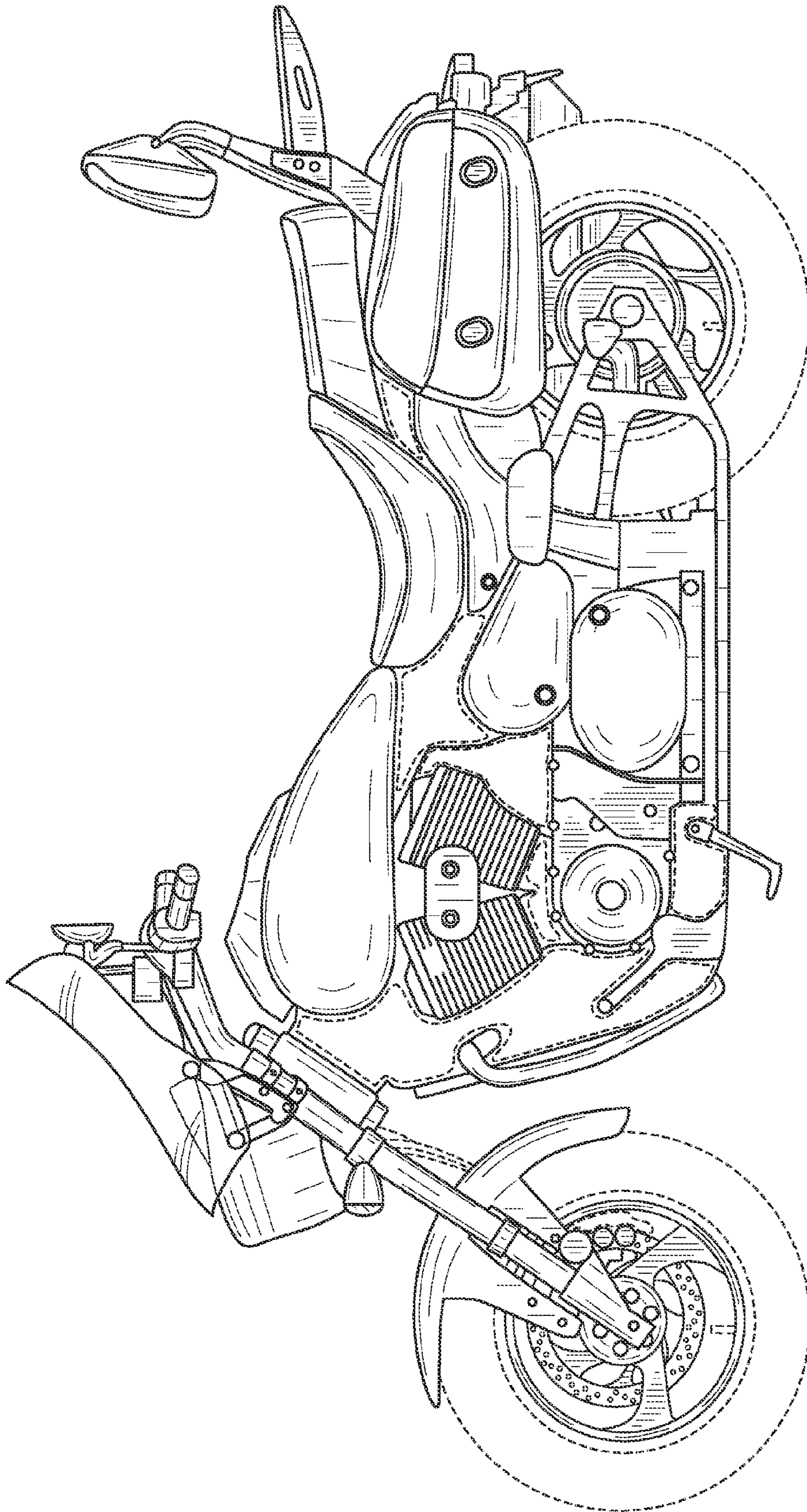

FIG. 4

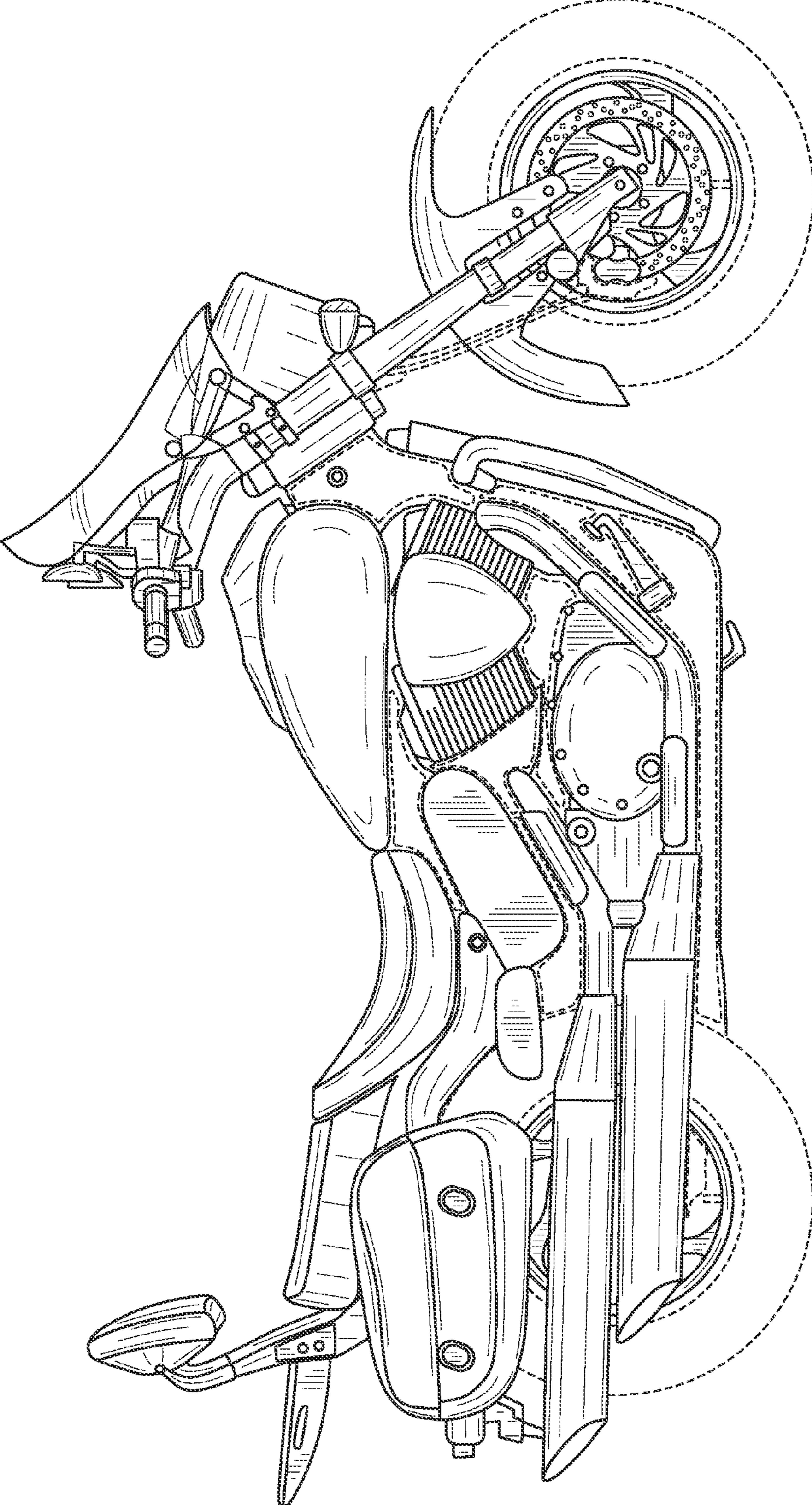

FIG. 5

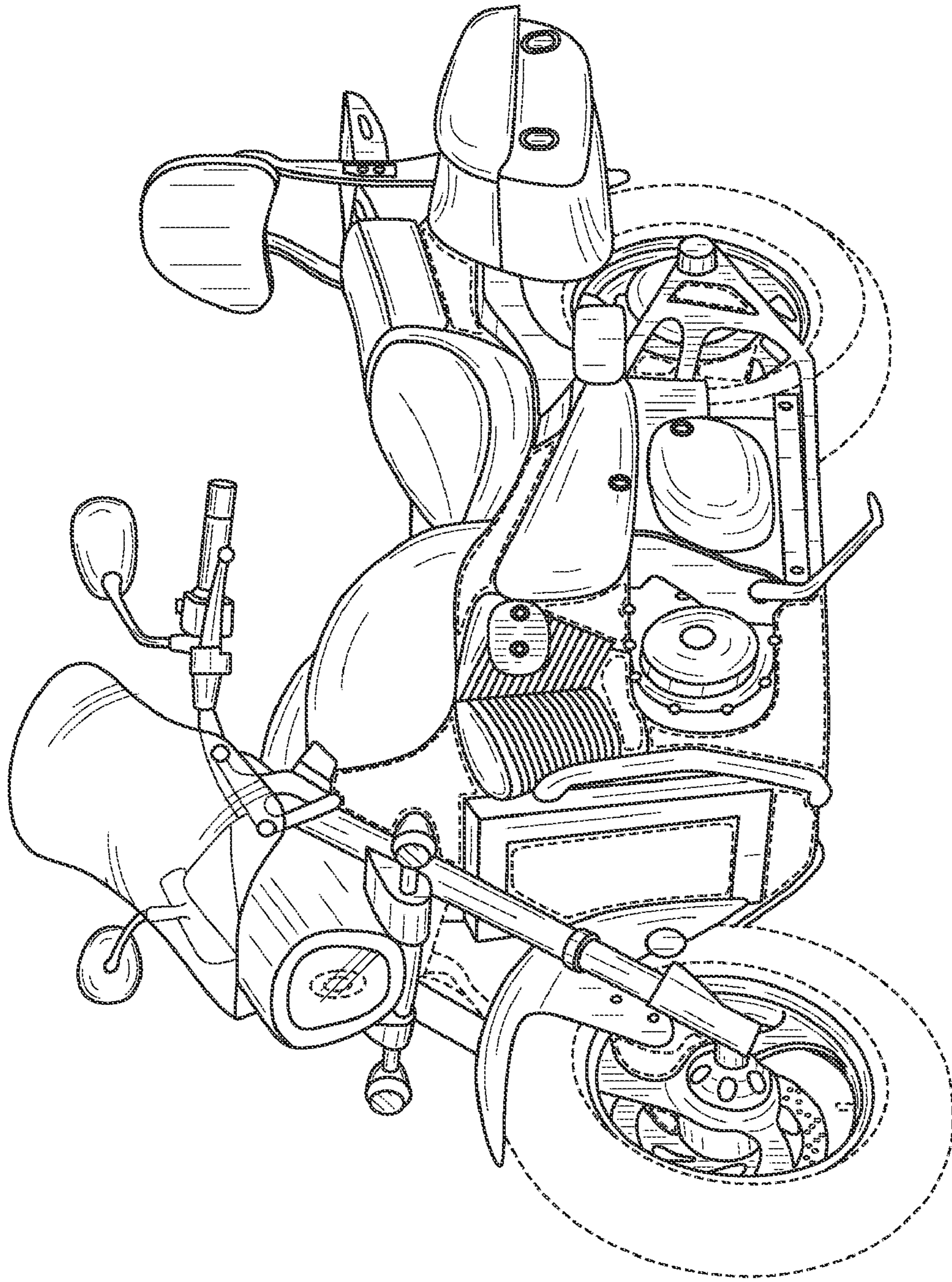

FIG. 6

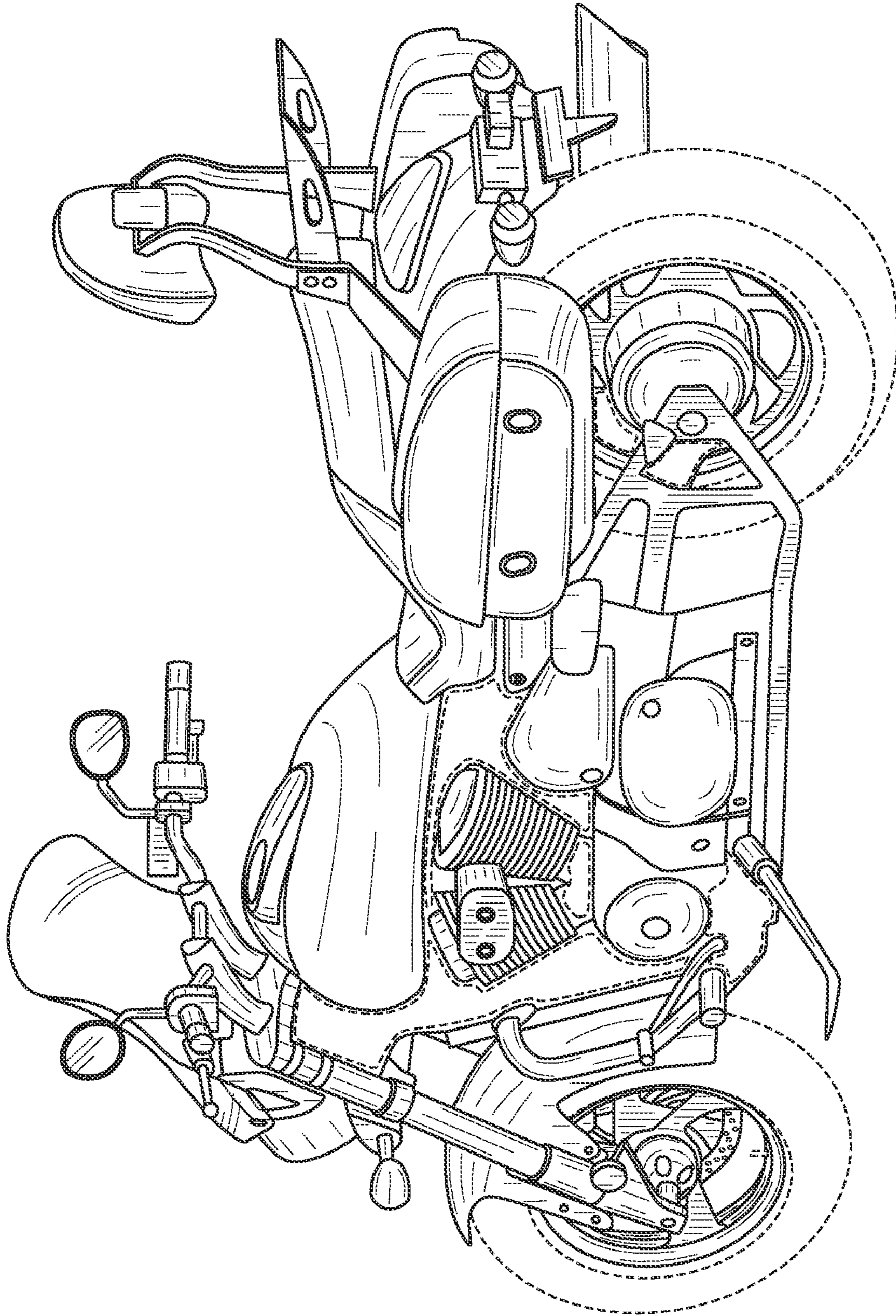

FIG. 7

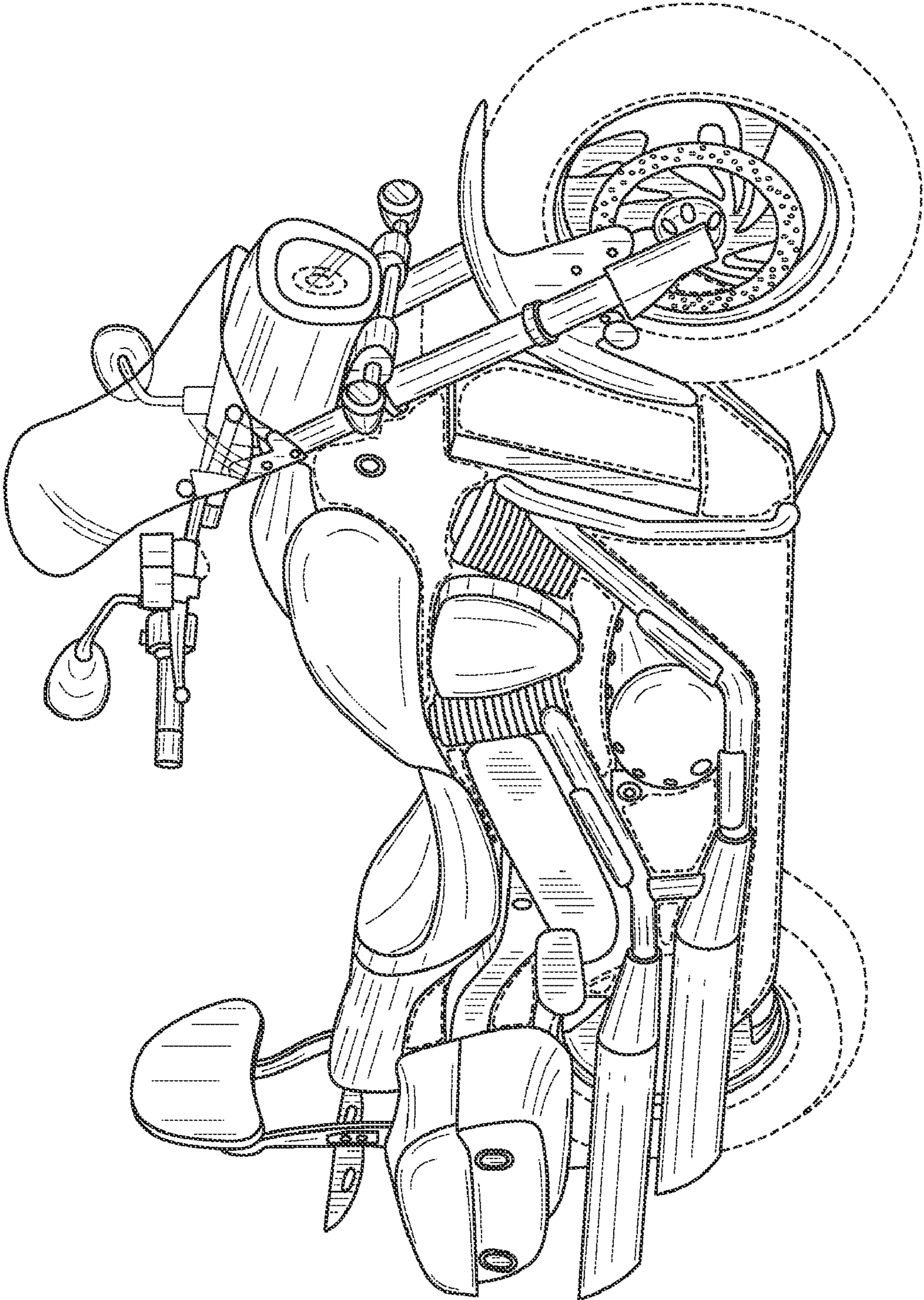

FIG. 8

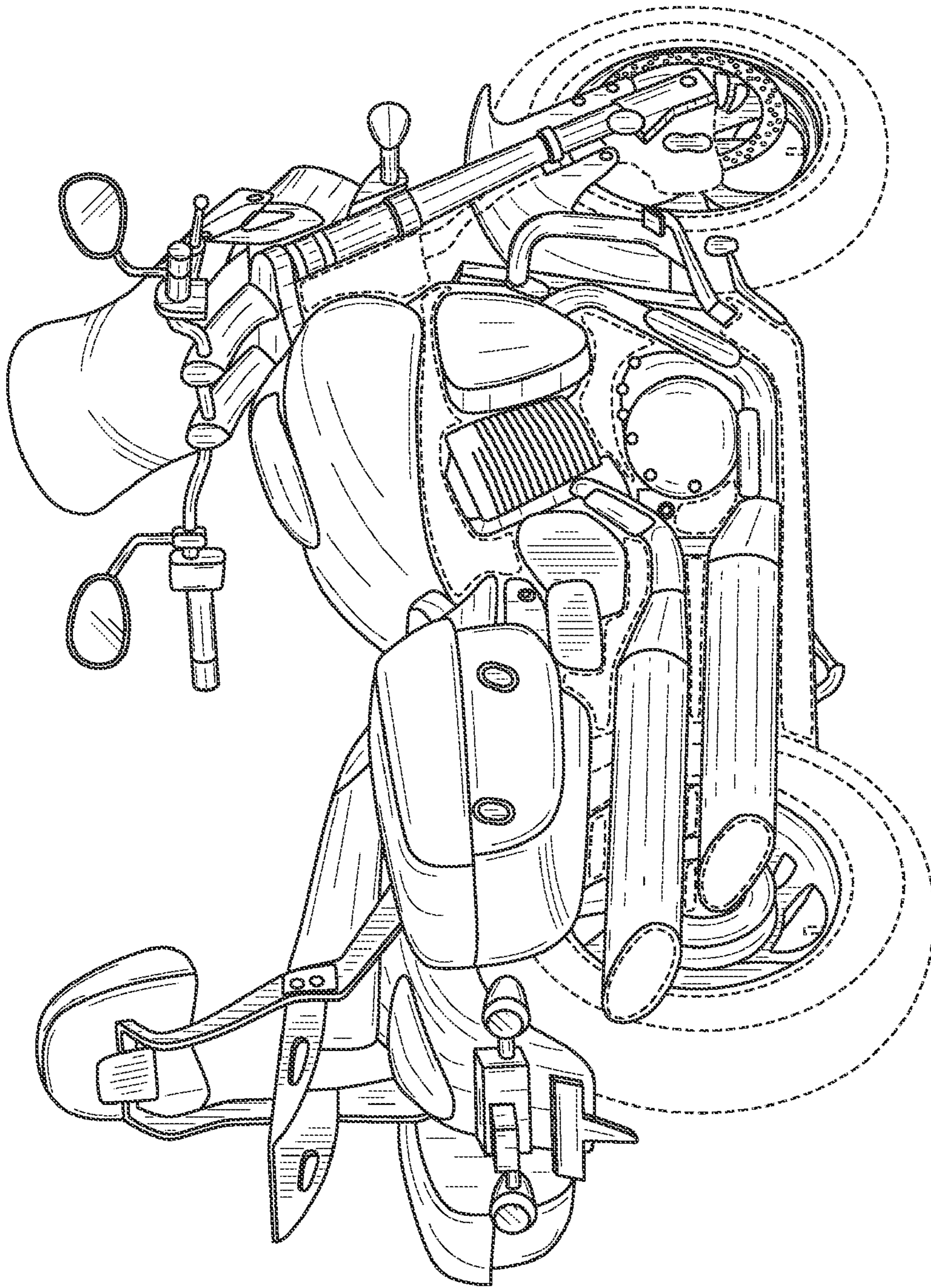

FIG. 9