



US00D637524S

(12) **United States Design Patent**
Lambri

(10) **Patent No.:** **US D637,524 S**

(45) **Date of Patent:** **** May 10, 2011**

(54) **MOTORCYCLE**

(75) Inventor: **Marco Lambri**, Pontedera (IT)

(73) Assignee: **Piaggio & C. S.p.A**, Pontedera (Pisa)
(IT)

(**) Term: **14 Years**

(21) Appl. No.: **29/349,270**

(22) Filed: **Mar. 19, 2010**

(30) **Foreign Application Priority Data**

Sep. 30, 2009 (EM) 001617689

(51) **LOC (9) Cl.** **12-11**

(52) **U.S. Cl.** **D12/110**

(58) **Field of Classification Search** D12/110;
180/219, 220, 225, 229

See application file for complete search history.

(56) **References Cited**

U.S. PATENT DOCUMENTS

D493,122 S * 7/2004 Huang et al. D12/110
D593,909 S * 6/2009 Chiu et al. D12/110

D599,710 S * 9/2009 Chen et al. D12/110
D601,928 S * 10/2009 Chen et al. D12/110
D617,237 S * 6/2010 Li D12/110

* cited by examiner

Primary Examiner — Susan M Lee

Assistant Examiner — Linda G. Brooks

(74) *Attorney, Agent, or Firm* — Hedman & Costigan, P.C.;
James V. Costigan

(57) **CLAIM**

The ornamental design for a motorcycle, as shown and described.

DESCRIPTION

FIG. 1 is a front side perspective view of the invention;
FIG. 2 is a front view of the invention;
FIG. 3 is a rear view of the invention;
FIG. 4 is a left side view of the invention;
FIG. 5 is a right side view of the invention; and
FIG. 6 is a top view of the invention; and,
FIG. 7 is a bottom view of the invention.
The small circle shown in broken lines in FIG. 4 forms no part of the claimed design.

1 Claim, 7 Drawing Sheets

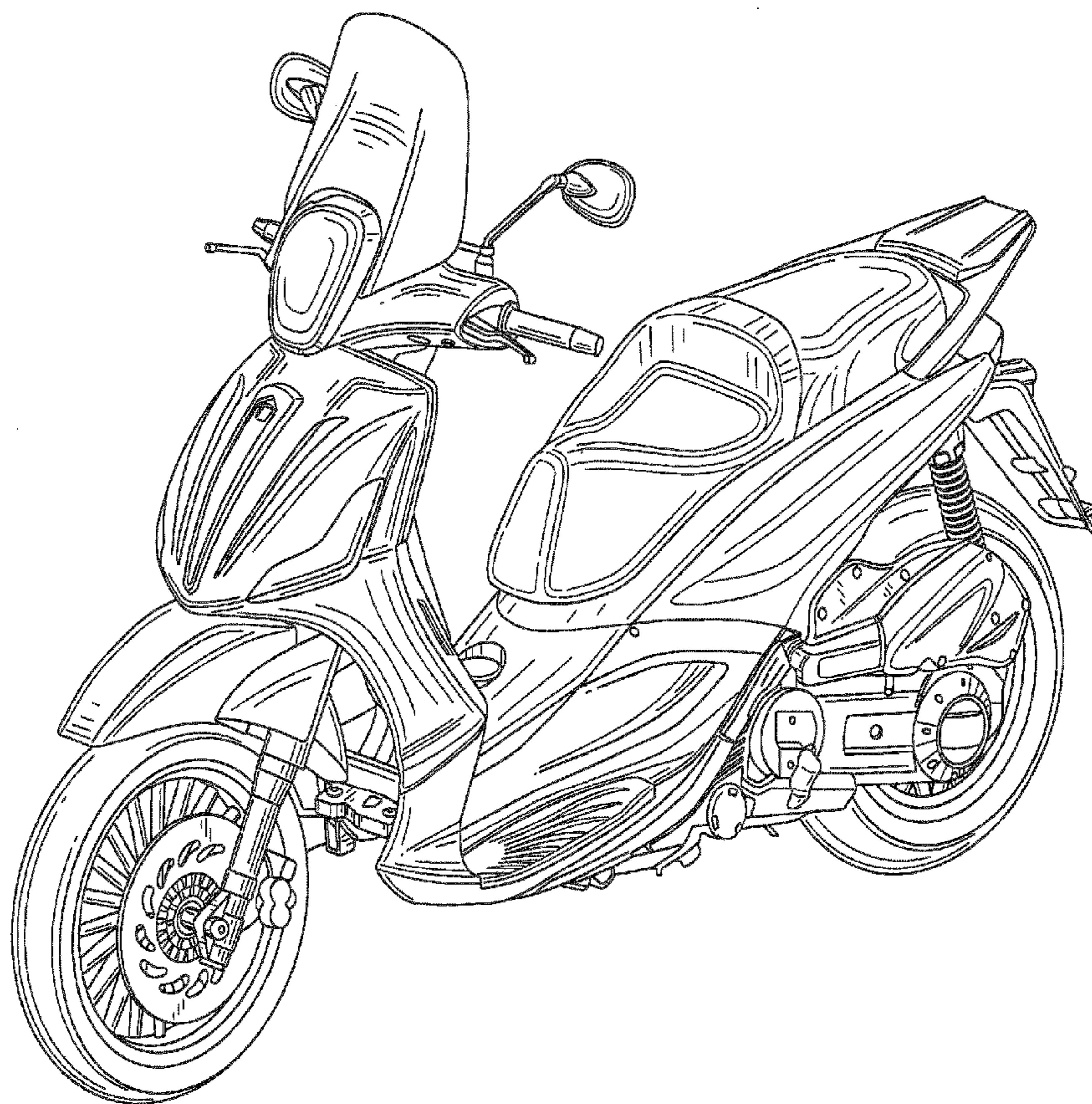

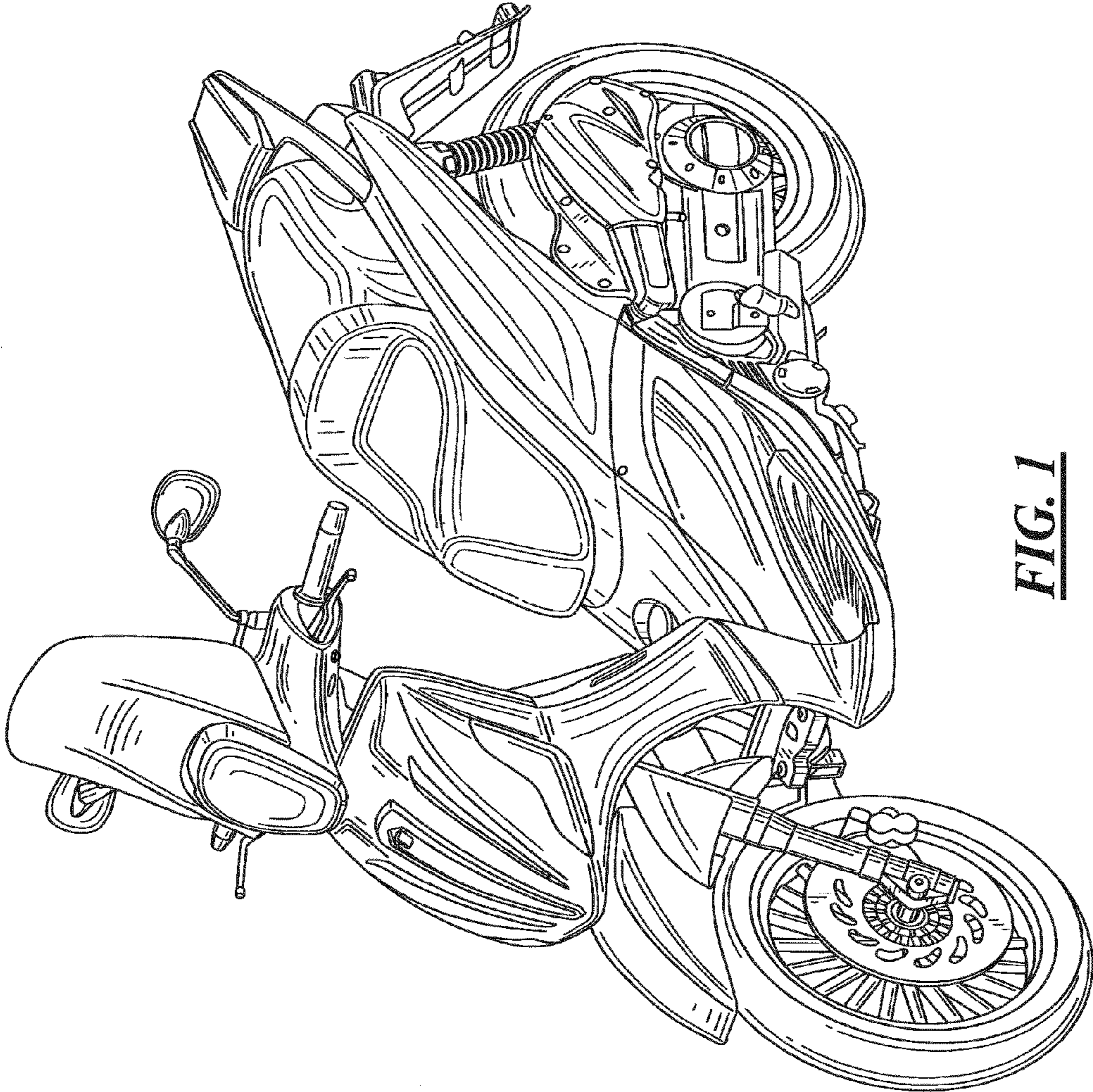

FIG. 1

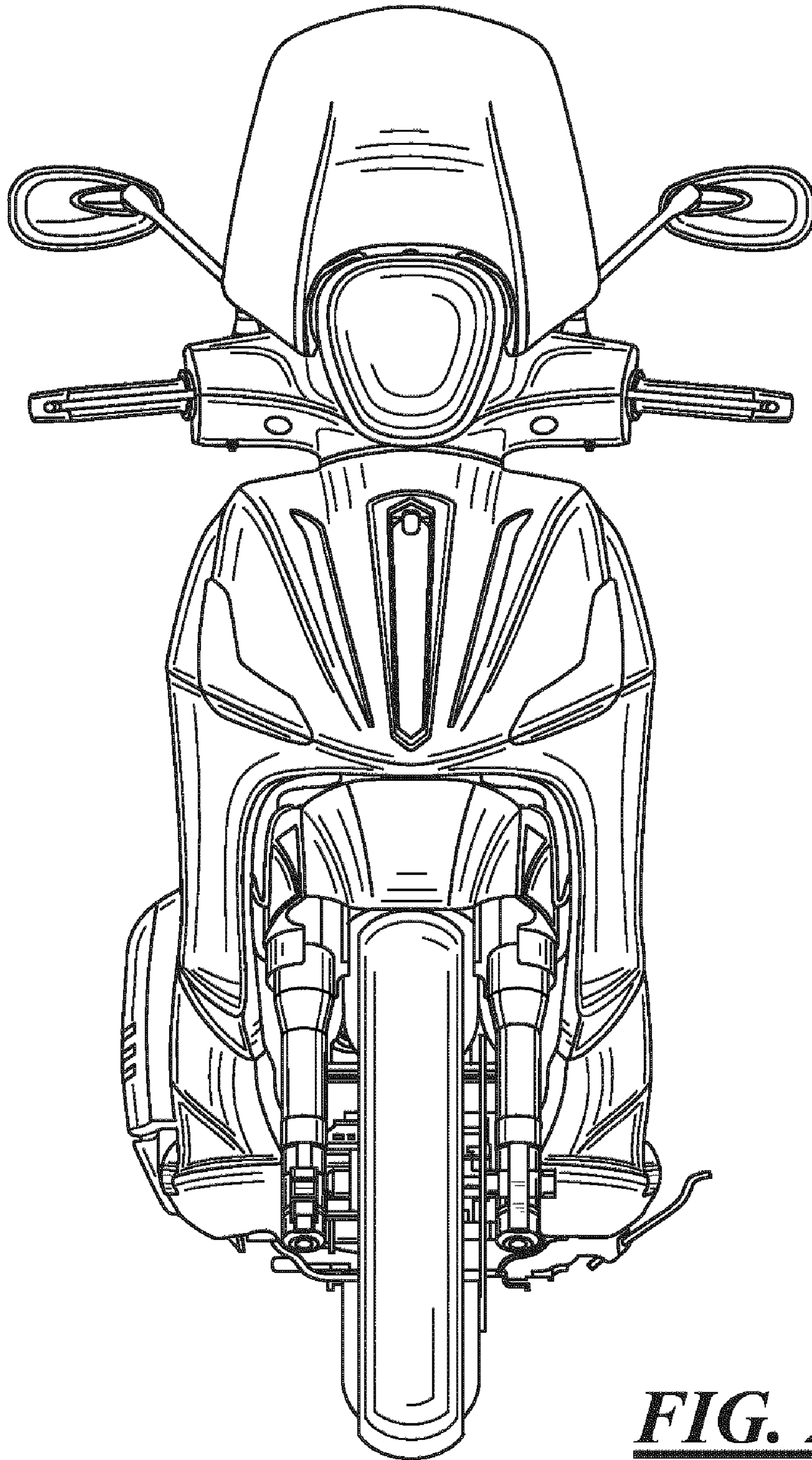

FIG. 2

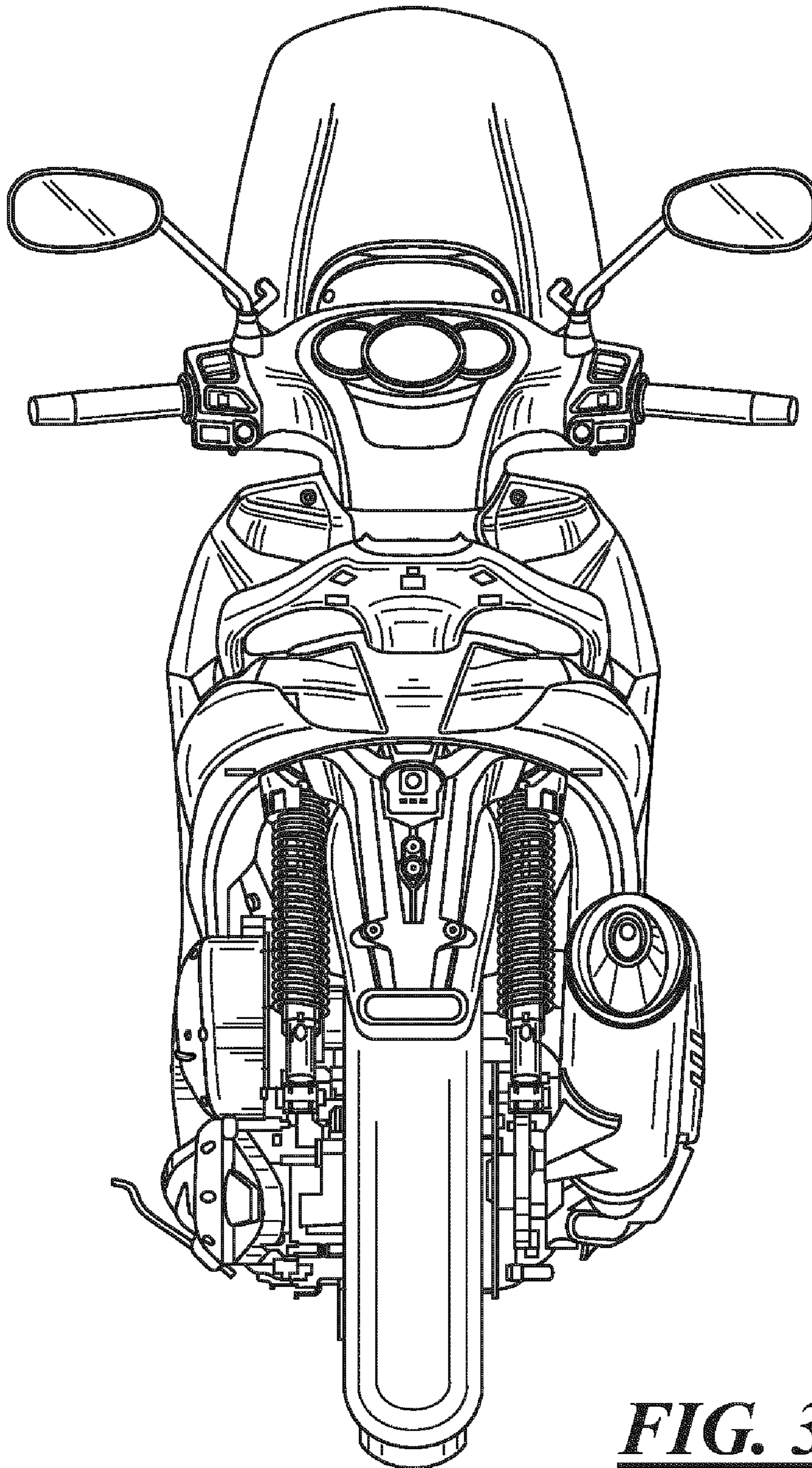

FIG. 3

FIG. 4

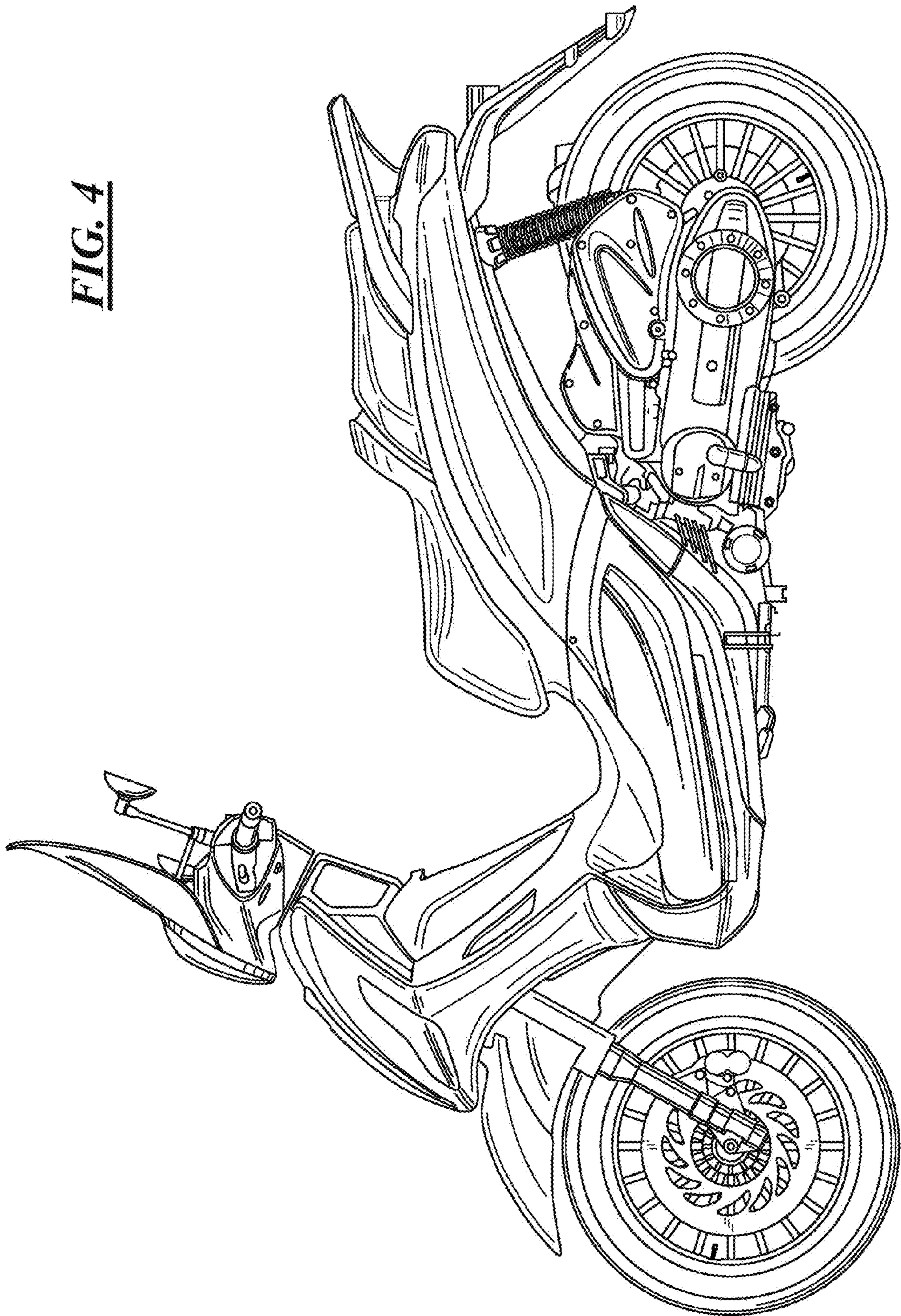
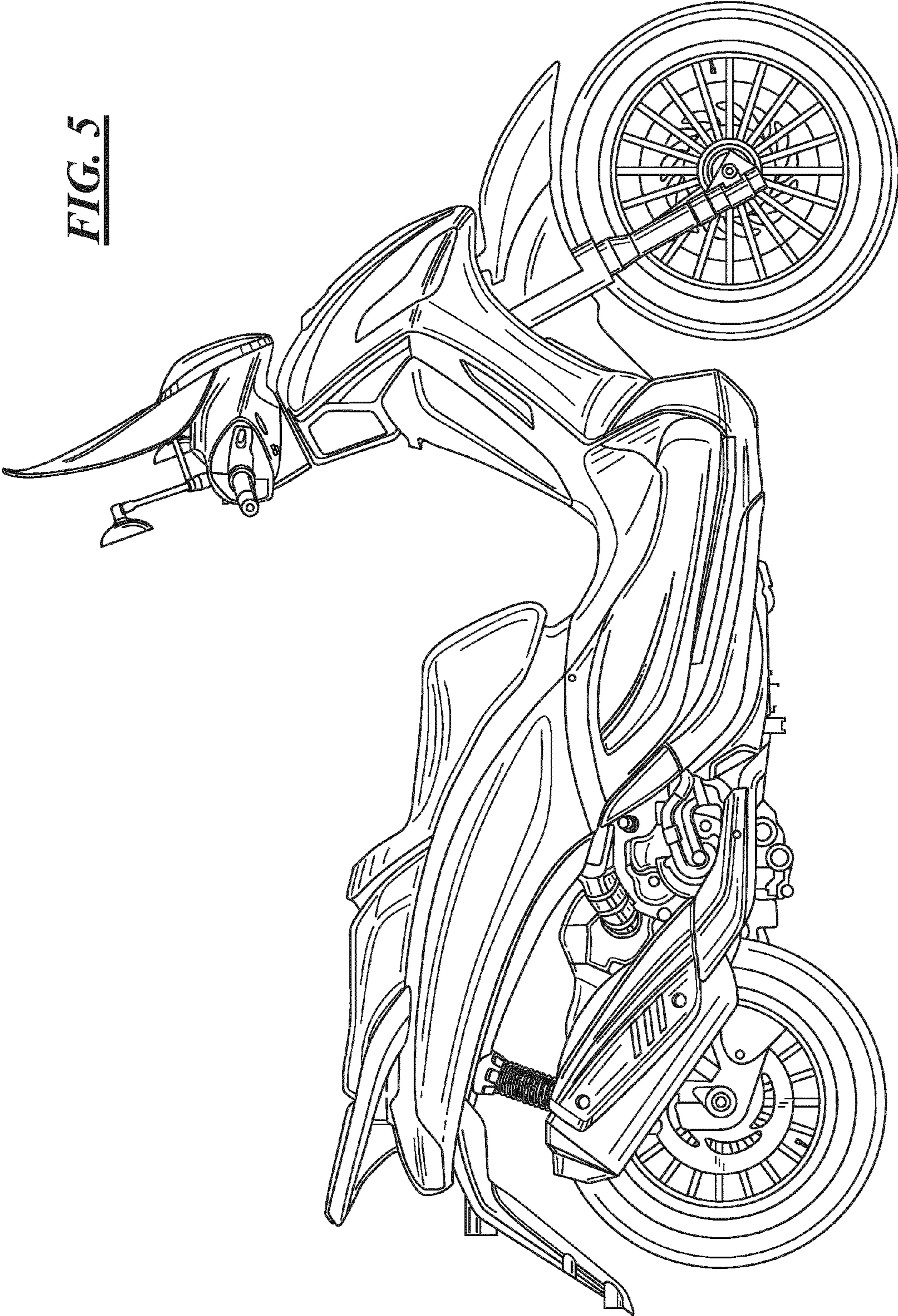

FIG. 5



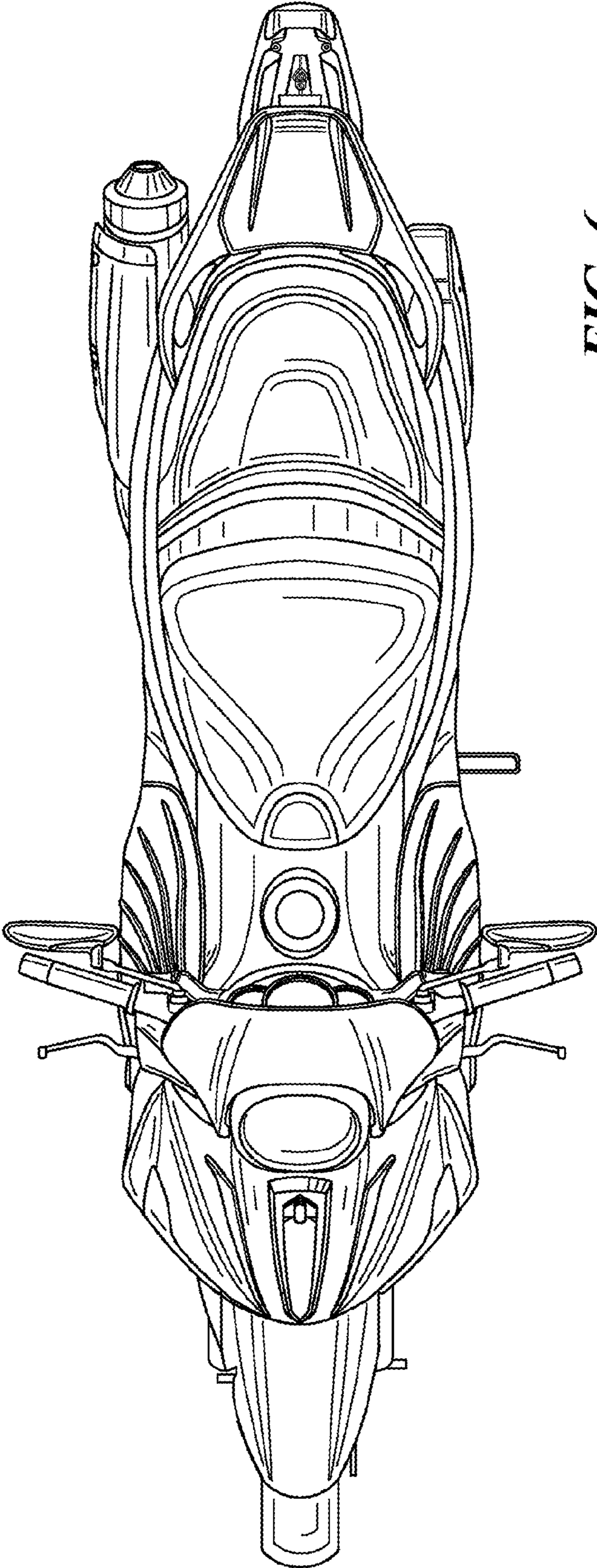

FIG. 6

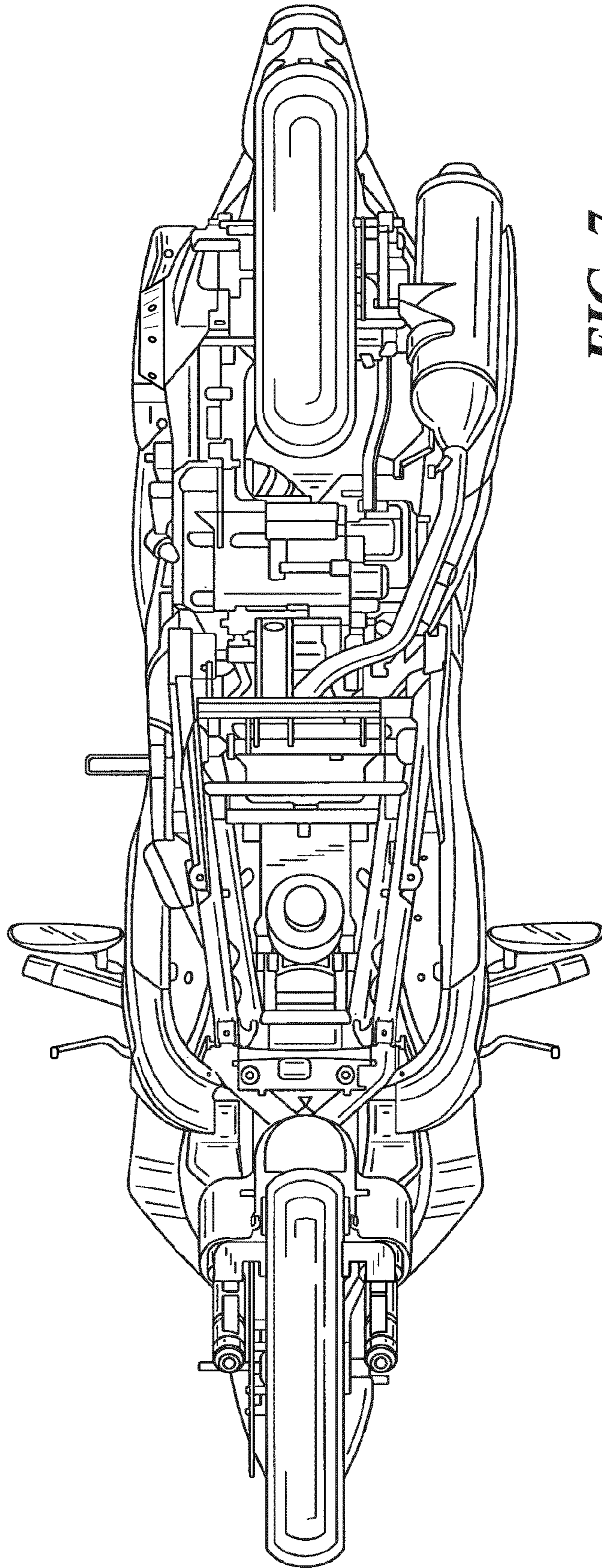

FIG. 7