



US00D637520S

(12) **United States Design Patent**
Kerr et al.

(10) **Patent No.:** **US D637,520 S**

(45) **Date of Patent:** **** May 10, 2011**

(54) **PASSENGER BUS**

(75) Inventors: **Andrew Kerr**, Winnipeg (CA); **Chris Watson**, Winnipeg (CA); **Ben Chao**, Winnipeg (CA); **Timothy Giesbrecht**, Winnipeg (CA); **Serge Carrier**, St-Jean-Chrysostome (CA)

(73) Assignee: **New Flyer Industries Canada ULC**, Winnipeg (CA)

(**) Term: **14 Years**

(21) Appl. No.: **29/331,953**

(22) Filed: **Feb. 5, 2009**

(51) **LOC (9) Cl.** **12-08**

(52) **U.S. Cl.** **D12/84**

(58) **Field of Classification Search** D12/82,
D12/84; 296/178

See application file for complete search history.

(56) **References Cited**

U.S. PATENT DOCUMENTS

D254,609 S *	4/1980	Neal et al.	D12/84
D255,340 S *	6/1980	Flesche	D12/84
D257,141 S *	9/1980	Flesche	D12/84
D376,562 S *	12/1996	Sealy et al.	D12/84
D503,126 S *	3/2005	Papke et al.	D12/84

OTHER PUBLICATIONS

Photographs of "Volgabus" dated Oct. 20, 2007.
"Proterra Coach"—San Diego APTA Show, Oct. 2008.

* cited by examiner

Primary Examiner — Melody N Brown
(74) *Attorney, Agent, or Firm* — Ogilvy Renault LLP

(57) **CLAIM**

We claim the ornamental design for a passenger bus, as shown and described.

DESCRIPTION

FIG. 1 is a top, front, and right side perspective view of a passenger bus showing our new design; FIG. 2 is a top, front, and left side perspective view thereof; FIG. 3 is a front elevation view thereof; FIG. 4 is a top plan view thereof; FIG. 5 is a right side elevation view thereof; FIG. 6 is a left side elevation view thereof; FIG. 7 is a rear elevation view thereof; and, FIG. 8 is a rear elevation view of a passenger bus showing a second embodiment of our new design. All other views are substantially the same as shown in FIGS. 1-6 of the first embodiment.

The environmental structures shown in broken lines throughout the drawings are for illustrative purposes only and form no part of the claimed design.

1 Claim, 7 Drawing Sheets

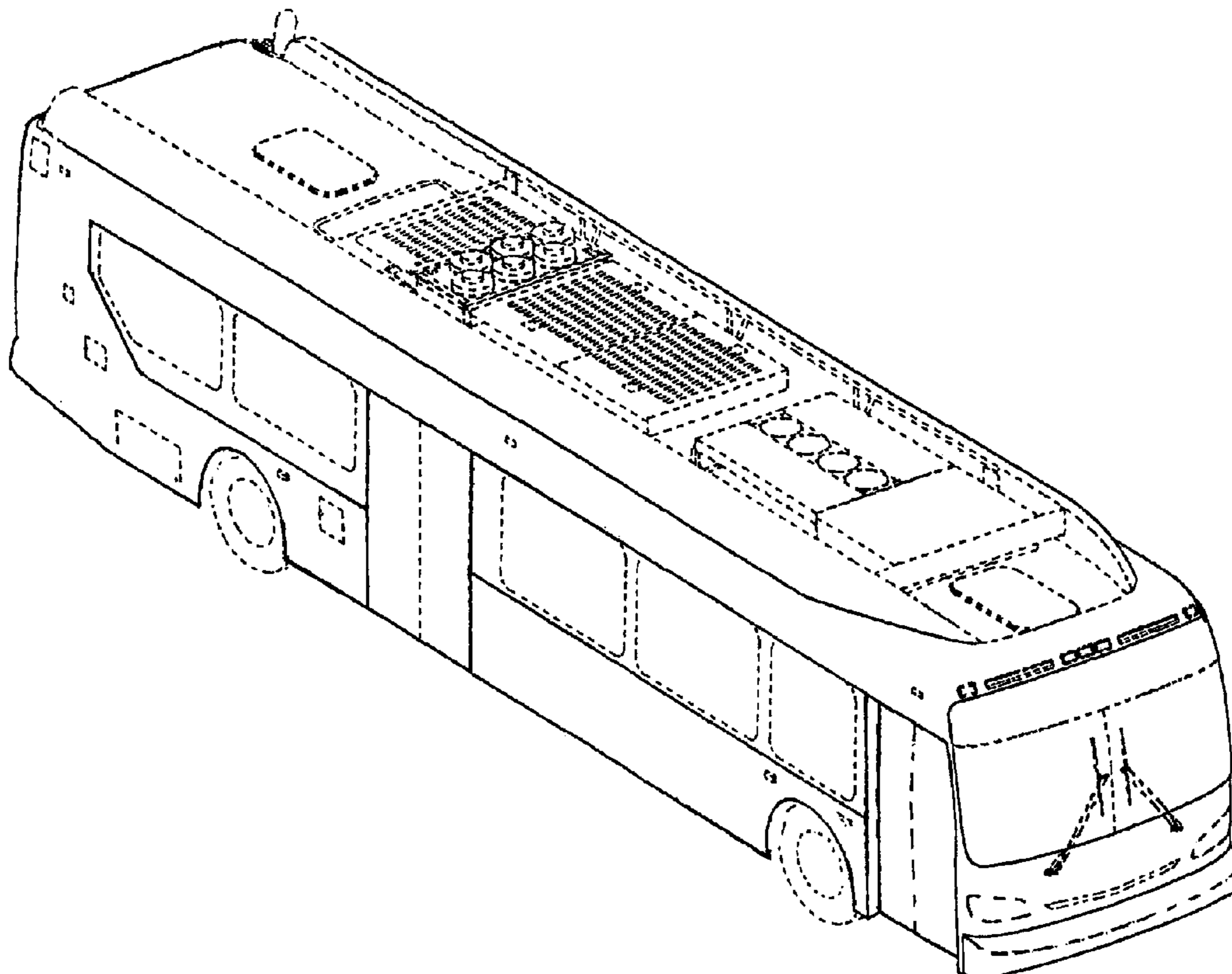

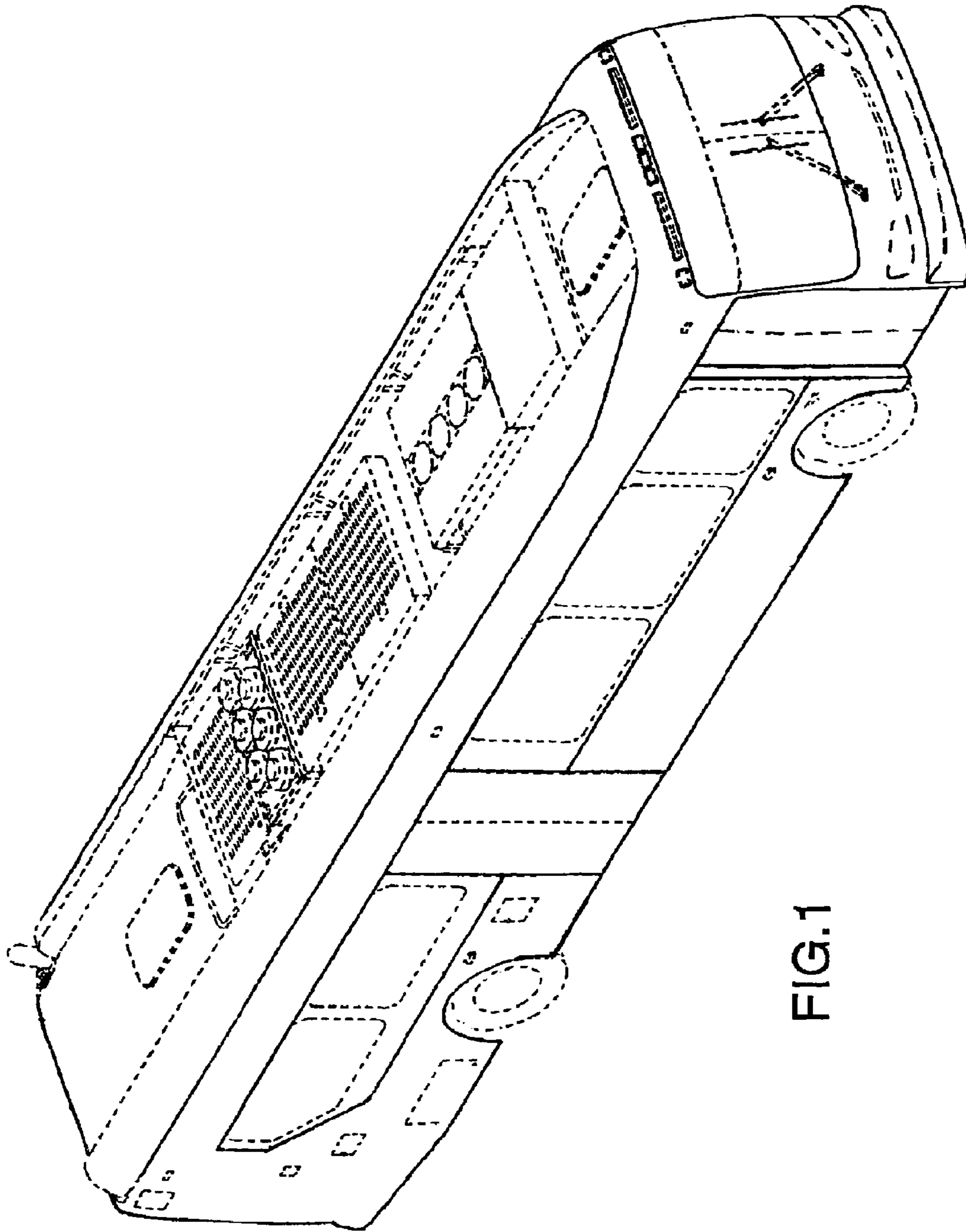

FIG.1

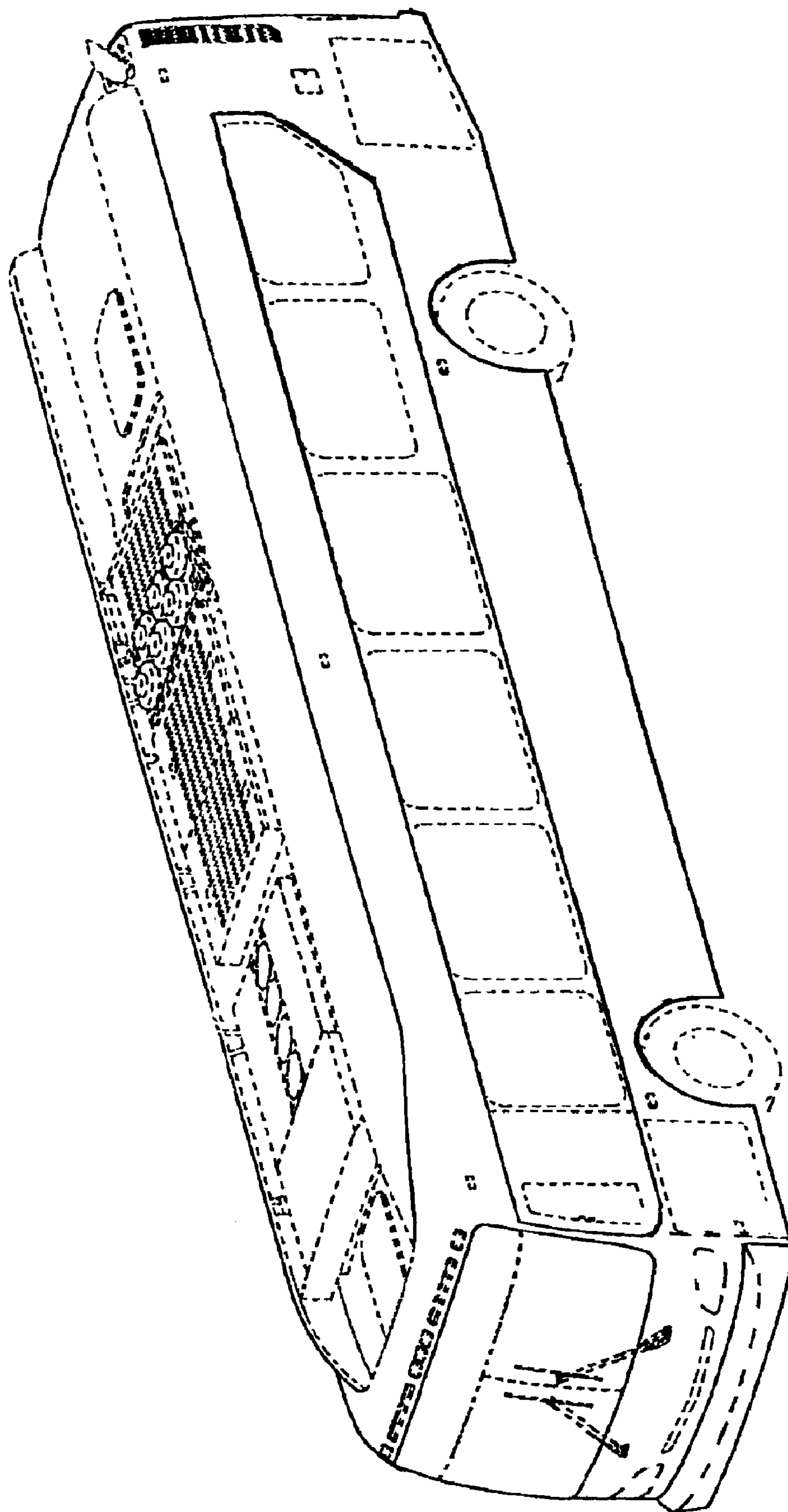

FIG.2

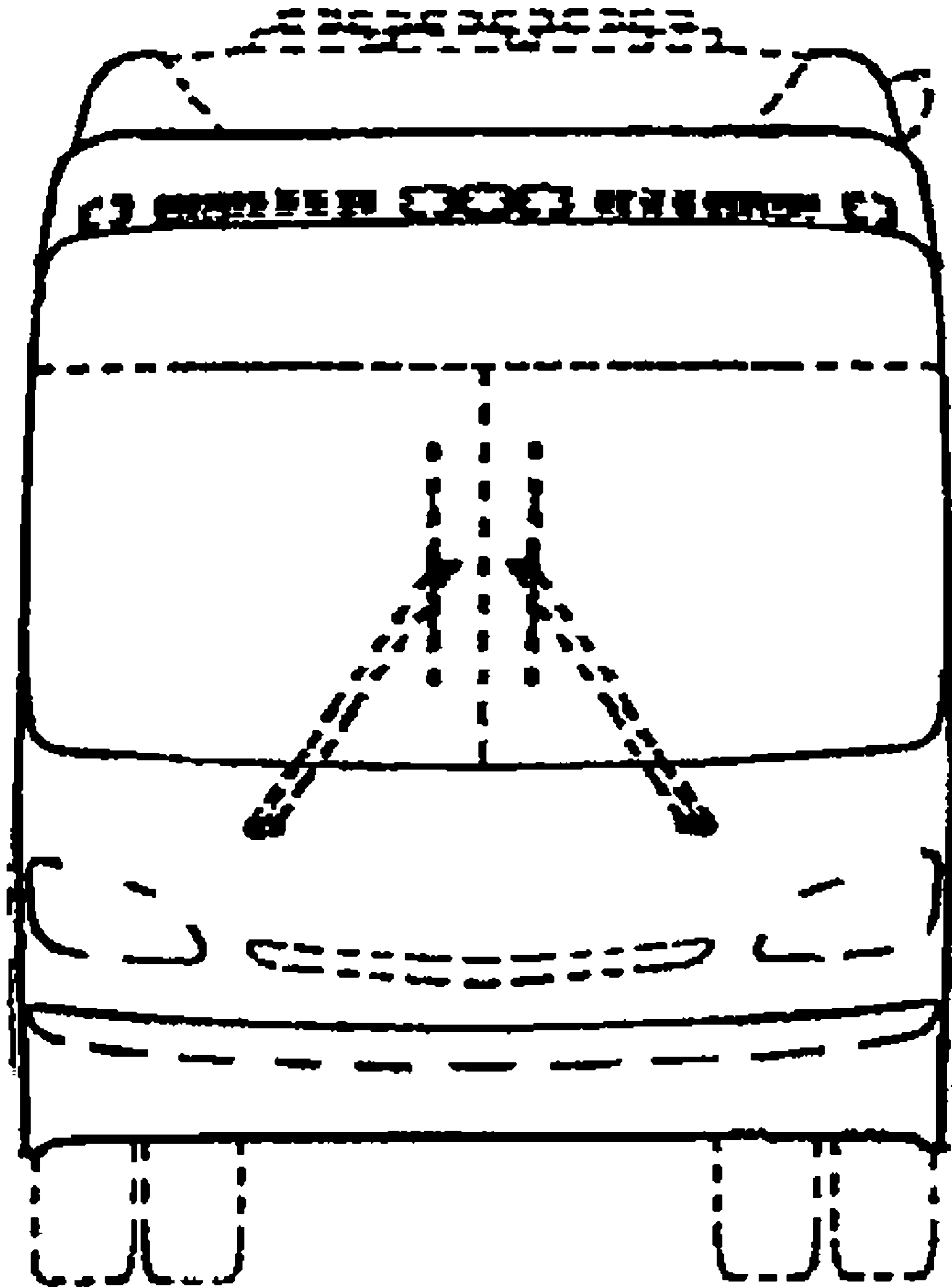

FIG.3

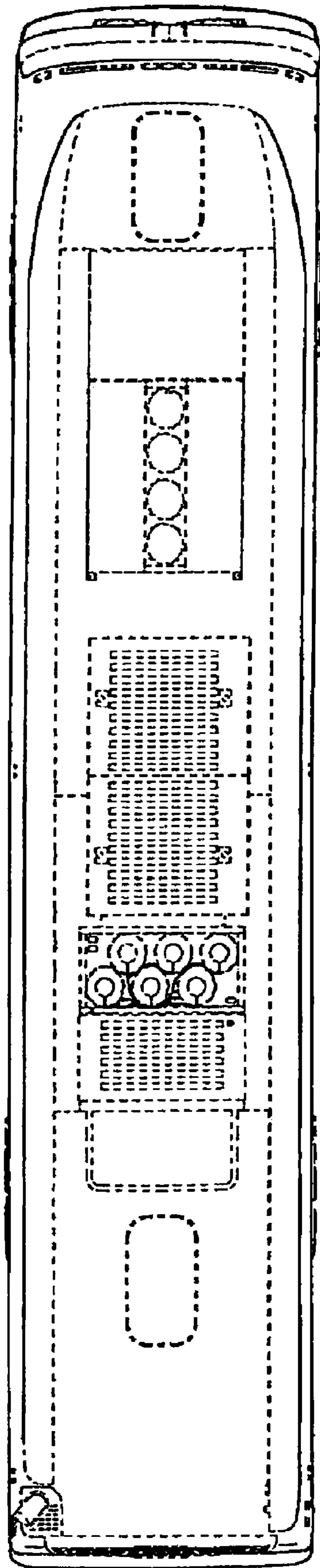

FIG.4

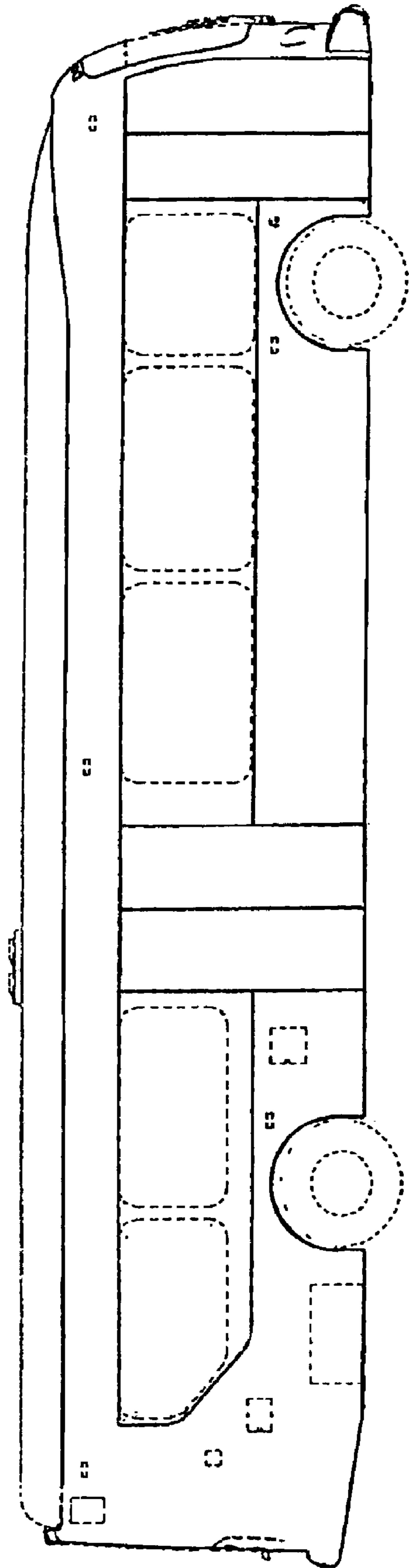

FIG.5

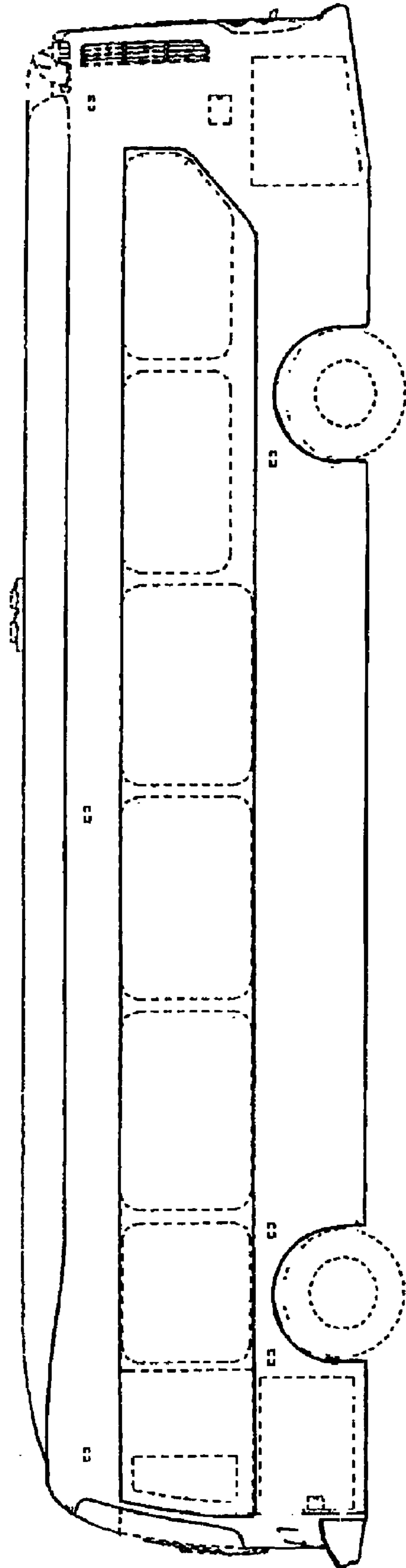

FIG. 6

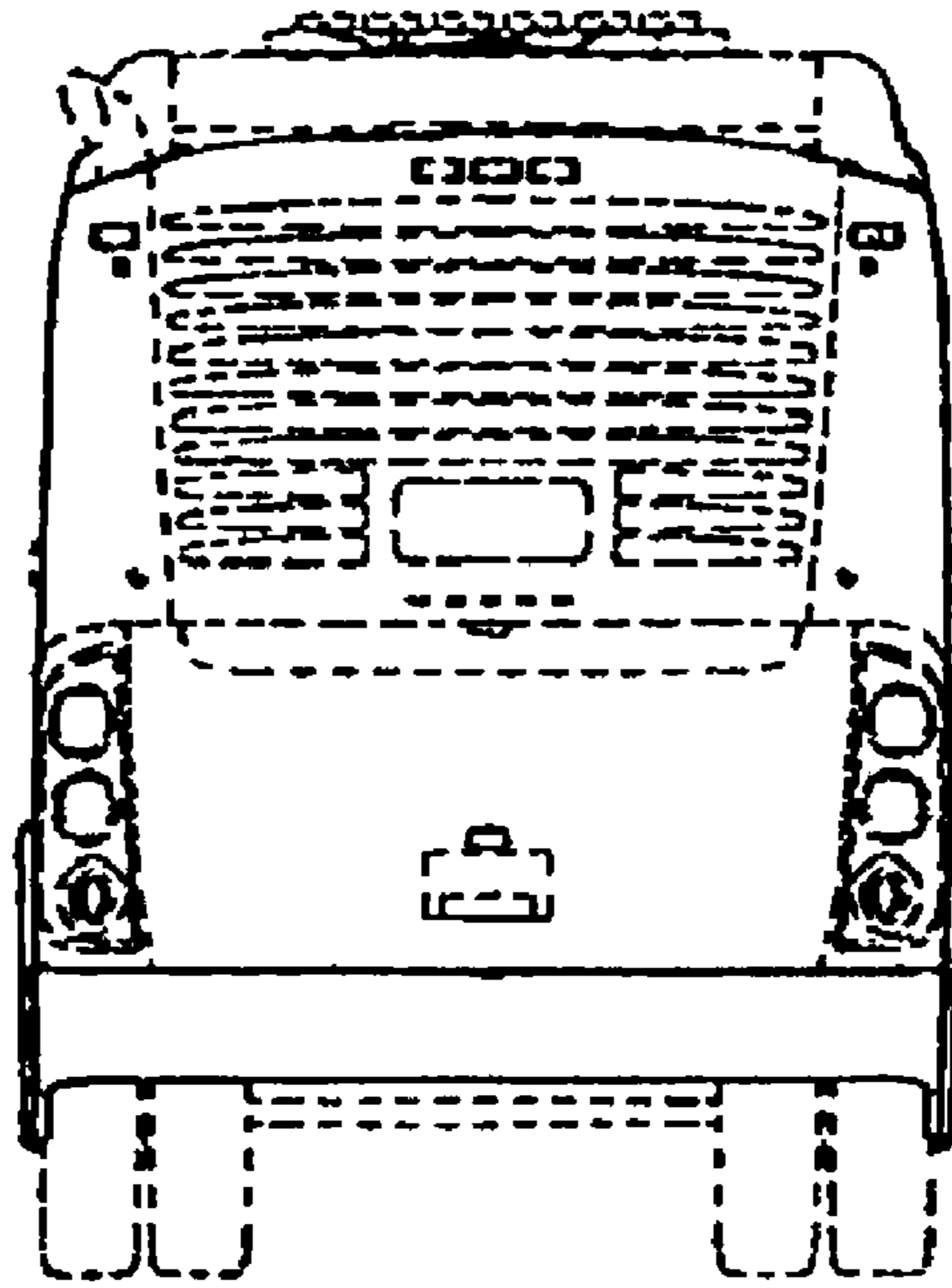

FIG. 7

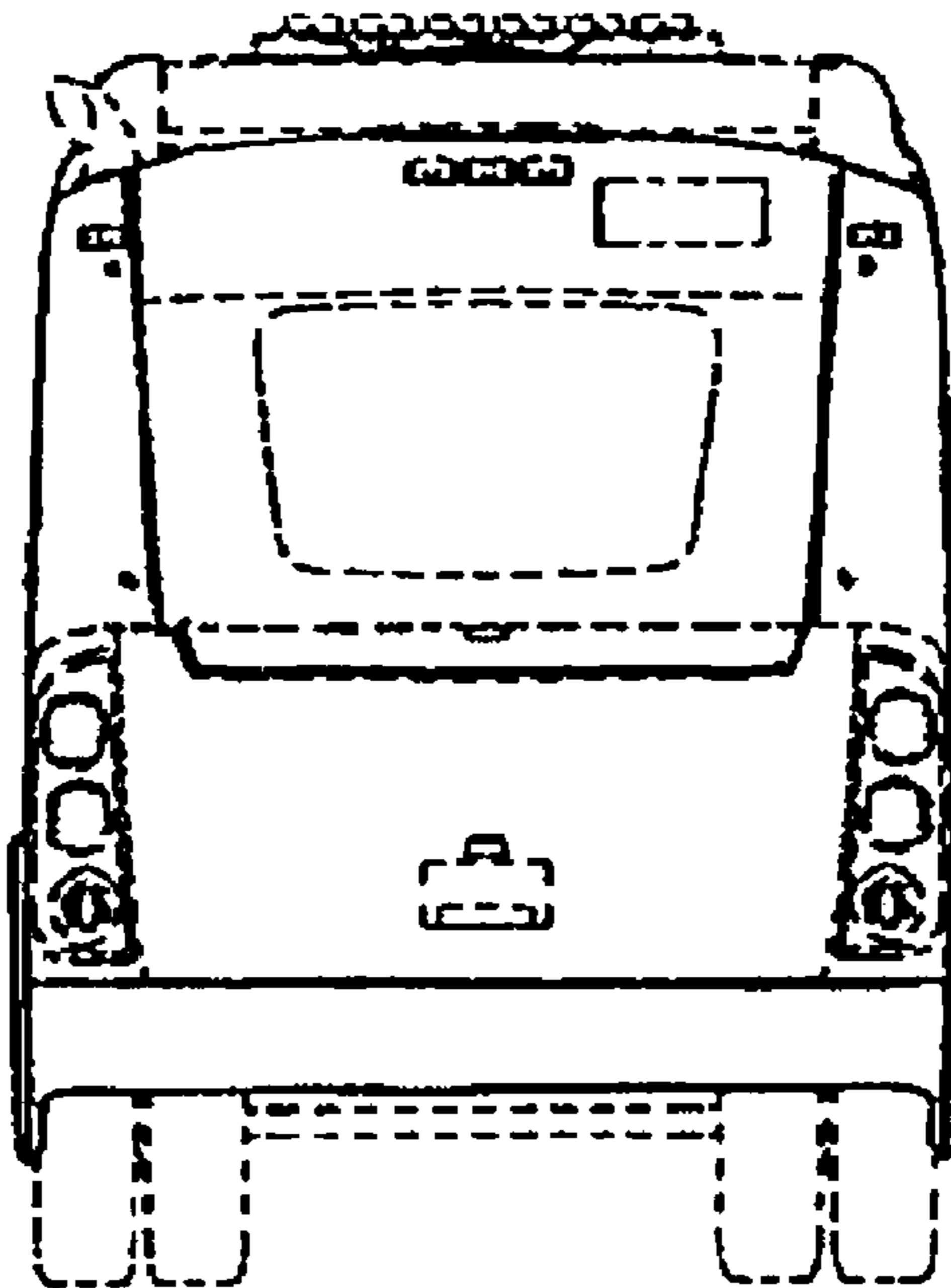

FIG. 8