



US00D637206S

(12) **United States Design Patent**
Luxon et al.

(10) **Patent No.:** **US D637,206 S**

(45) **Date of Patent:** **** May 3, 2011**

(54) **PORTION OF AN AIR RAM INTAKE FOR A VEHICLE**

(75) Inventors: **Peter Luxon**, South Croydon (AU);
Manvir Randhawa, South Croydon (AU)

(73) Assignee: **Australian Performance Development Pty Ltd**, South Croydon VIC (AU)

(**) Term: **14 Years**

(21) Appl. No.: **29/347,786**

(22) Filed: **Jun. 4, 2010**

(30) **Foreign Application Priority Data**

Dec. 4, 2009 (AU) 14735/2009

(51) **LOC (9) Cl.** **15-01**

(52) **U.S. Cl.** **D15/5; D12/400**

(58) **Field of Classification Search** D15/1-6;
123/184.21, 184.24, 184.34, 184.35, 23.2,
123/184.48, 184.42; D12/400, 194, 206,
D12/418; D24/110.5, 110.6

See application file for complete search history.

(56) **References Cited**

U.S. PATENT DOCUMENTS

6,564,766 B2 * 5/2003 Ayton 123/184.21
6,637,537 B2 * 10/2003 Porter et al. 180/309
6,966,292 B2 * 11/2005 Huang 123/184.21
D532,019 S * 11/2006 Huang D15/5
D545,725 S * 7/2007 Zimbardo D12/114
7,281,511 B2 * 10/2007 Quezada 123/184.53
D562,749 S * 2/2008 LaRussa D12/194

7,685,985 B2 * 3/2010 Madeira 123/184.21
D627,369 S * 11/2010 Troxell D15/5
2002/0179030 A1 * 12/2002 Fiesel et al. 123/184.42
2003/0019456 A1 * 1/2003 Ayton 123/184.21
2006/0185639 A1 * 8/2006 Rosenbaum 123/184.21
2006/0196462 A1 * 9/2006 Quezada 123/184.21
2010/0083928 A1 * 4/2010 Saito et al. 123/184.56
2010/0229817 A1 * 9/2010 Hirai 123/184.21
2010/0229818 A1 * 9/2010 Silvano 123/184.21

* cited by examiner

Primary Examiner — T. Chase Nelson

Assistant Examiner — Ania K Dworzecka

(74) *Attorney, Agent, or Firm* — Duane Morris LLP

(57) **CLAIM**

The ornamental design for a portion of an air ram intake for a vehicle, as shown and described.

DESCRIPTION

FIG. 1 is a front elevational view of the portion of an air ram intake for a vehicle of the present invention.

FIG. 2 is rear elevational view of the present invention.

FIG. 3 is a left side elevational view of the present invention.

FIG. 4 is a right side elevational view of the present invention.

FIG. 5 is a top plan view of the present invention.

FIG. 6 is a bottom plan view of the present invention.

FIG. 7 is a front left perspective view of the present invention; and,

FIG. 8 is a rear left perspective view of the present invention.

The broken lines showing environmental structure are for illustrative purposes only and form no part of the claimed design.

1 Claim, 8 Drawing Sheets

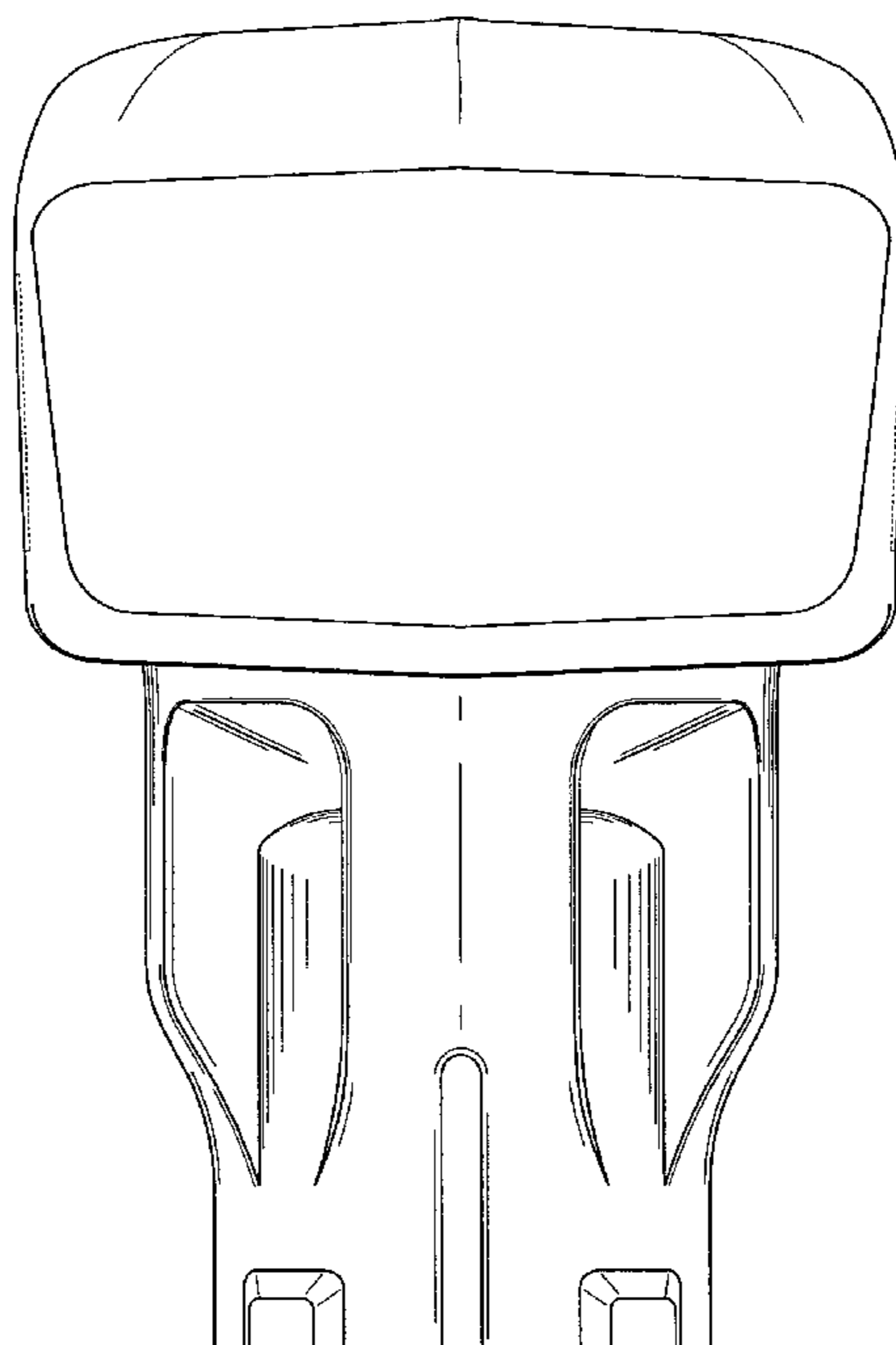

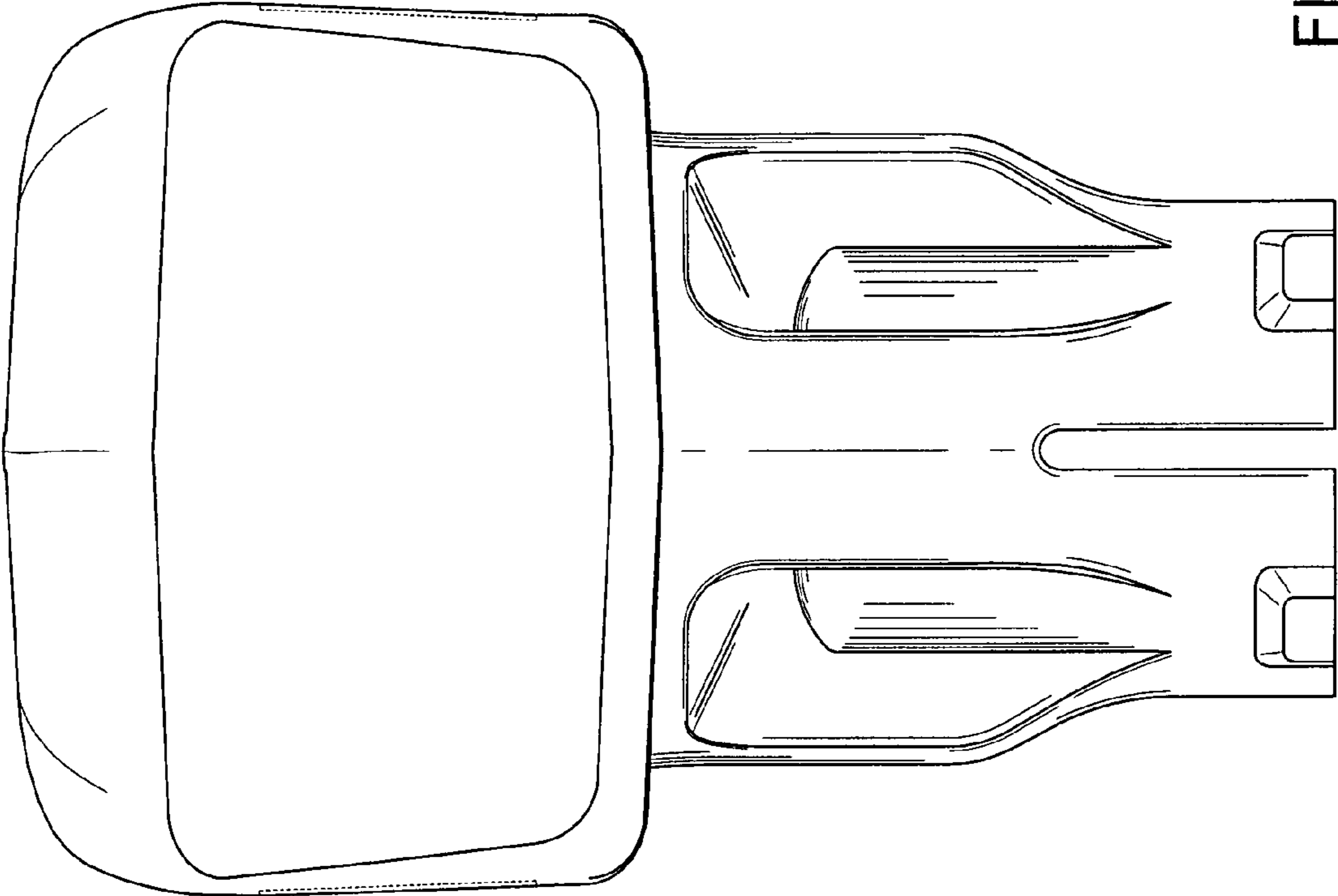

FIG. 1

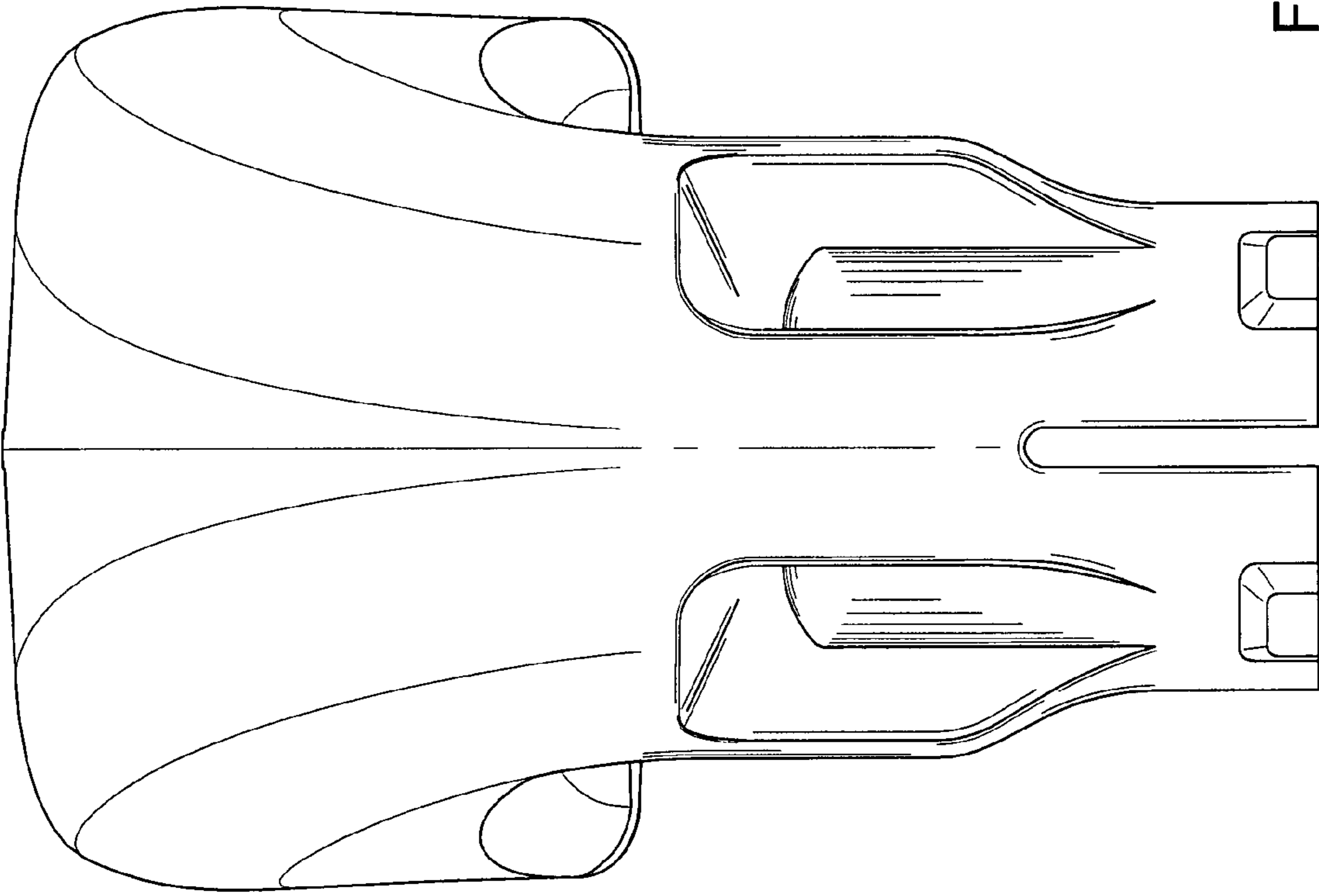

FIG. 2

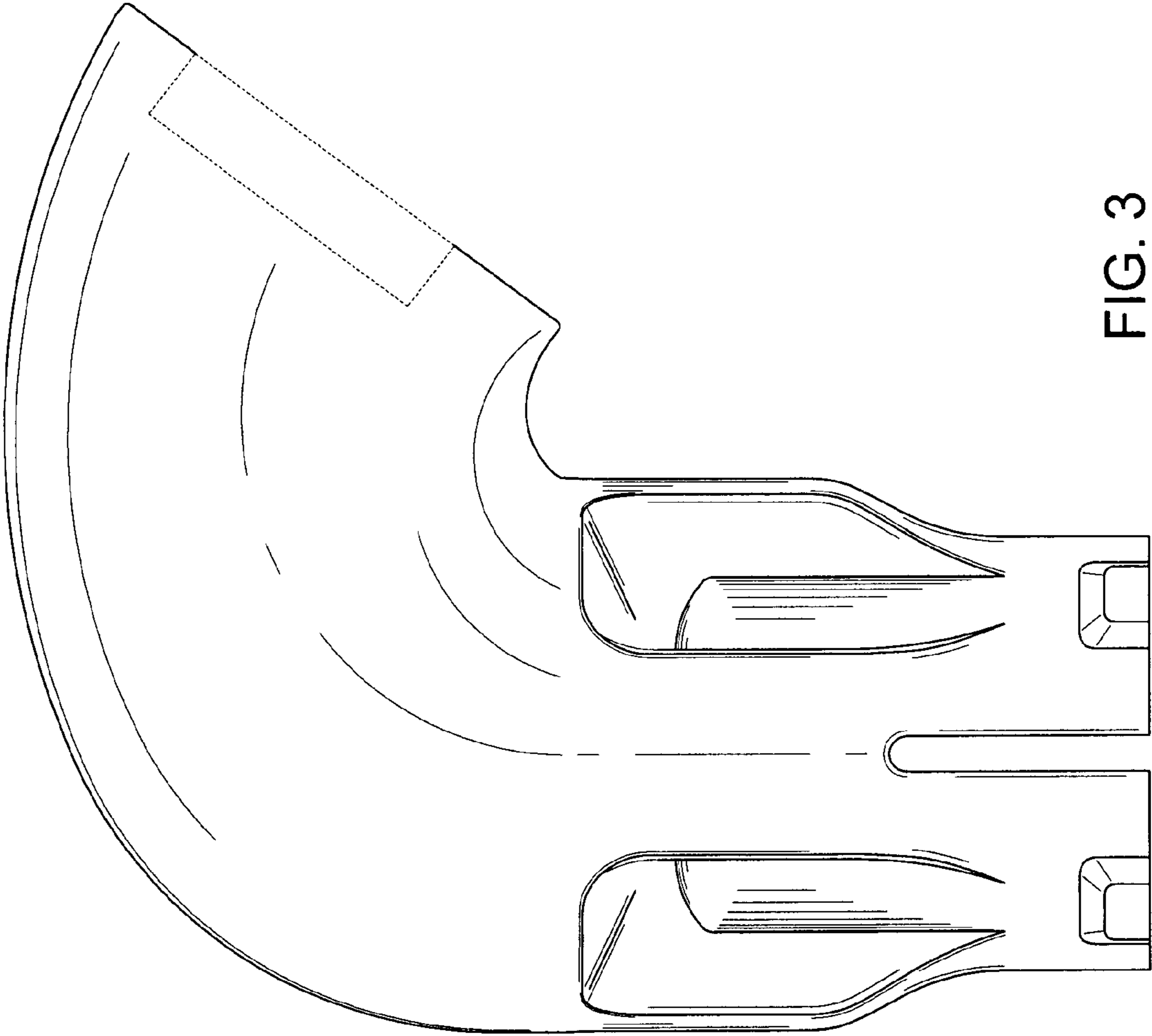

FIG. 3

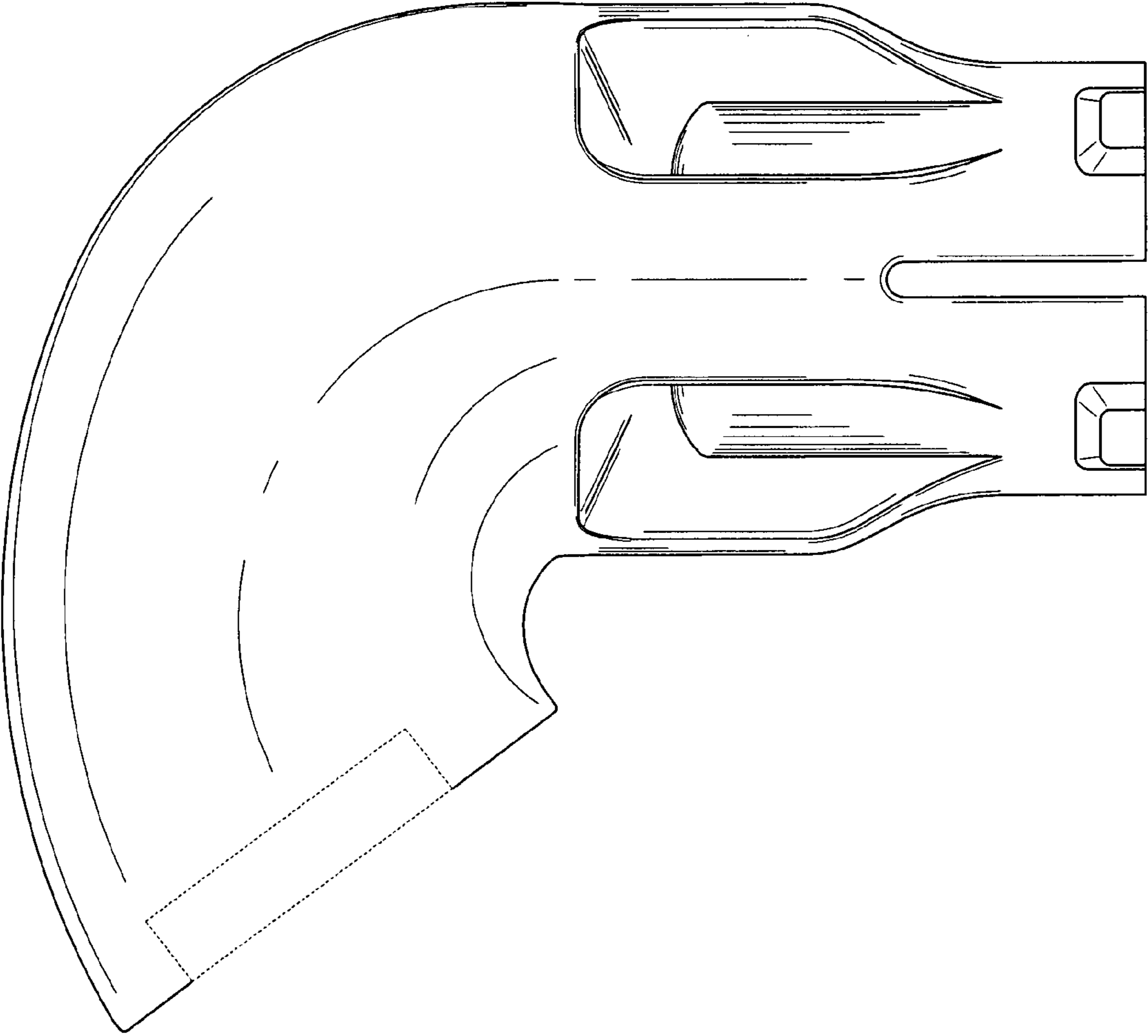

FIG. 4

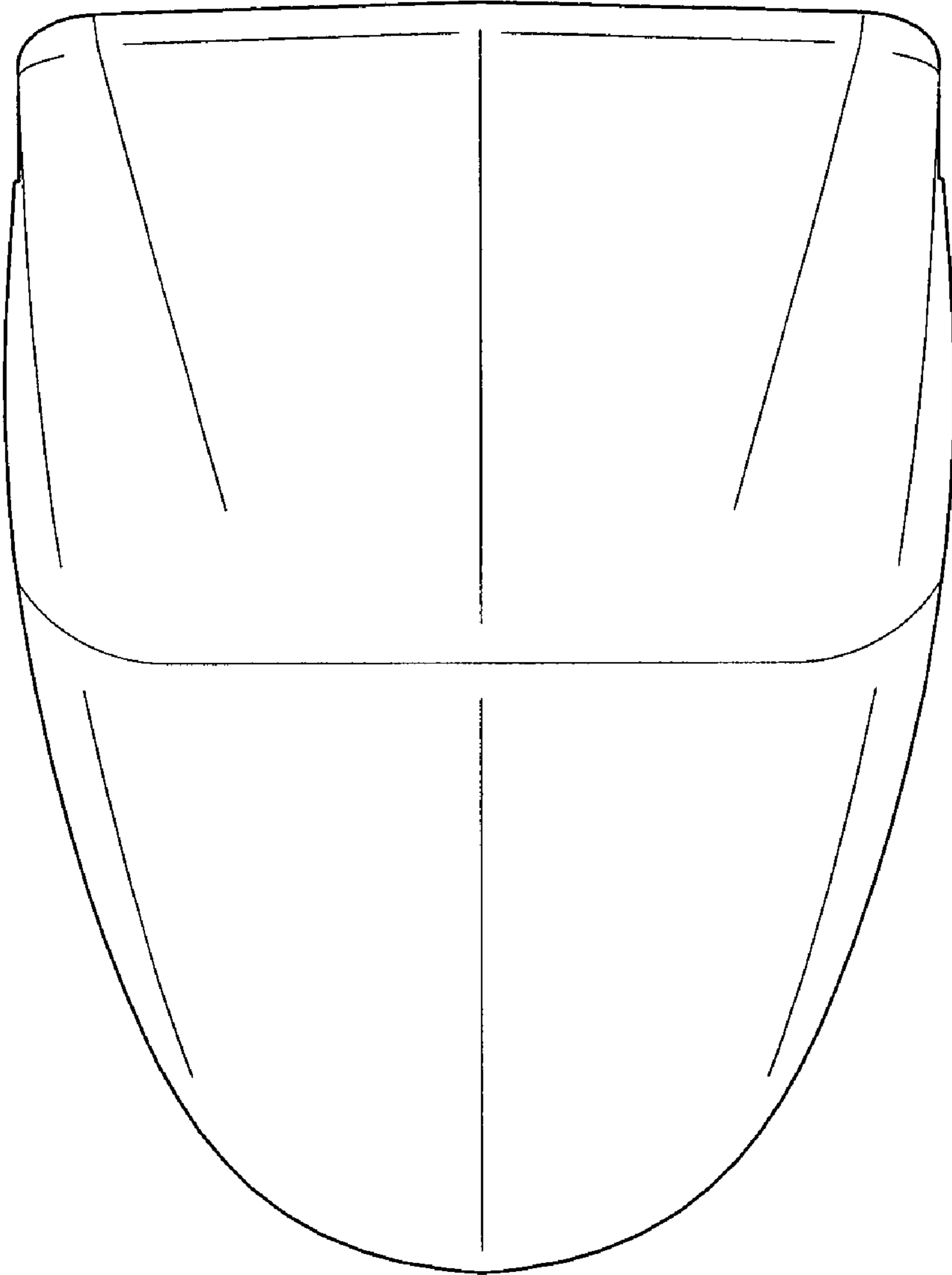

FIG. 5

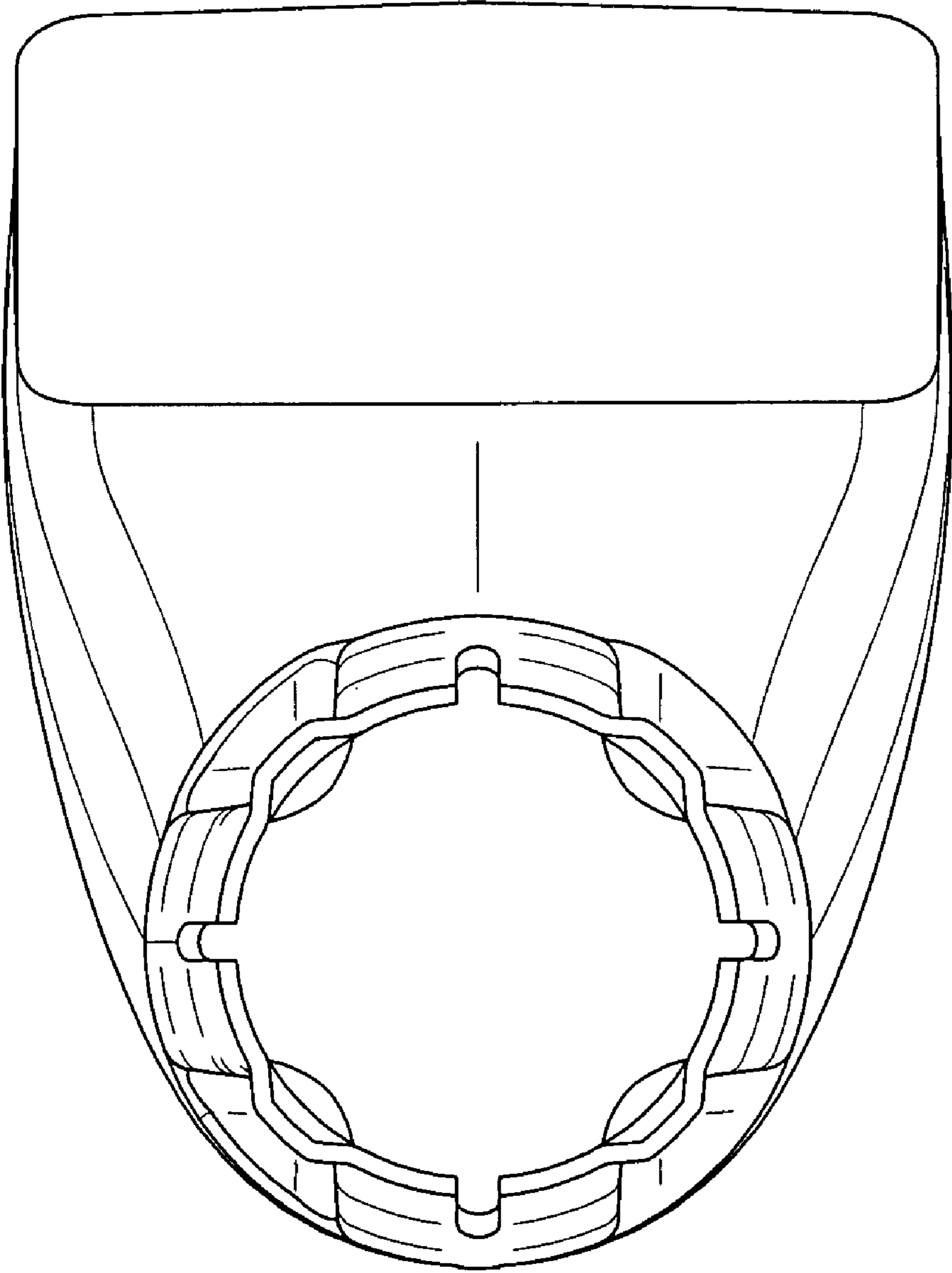

FIG. 6

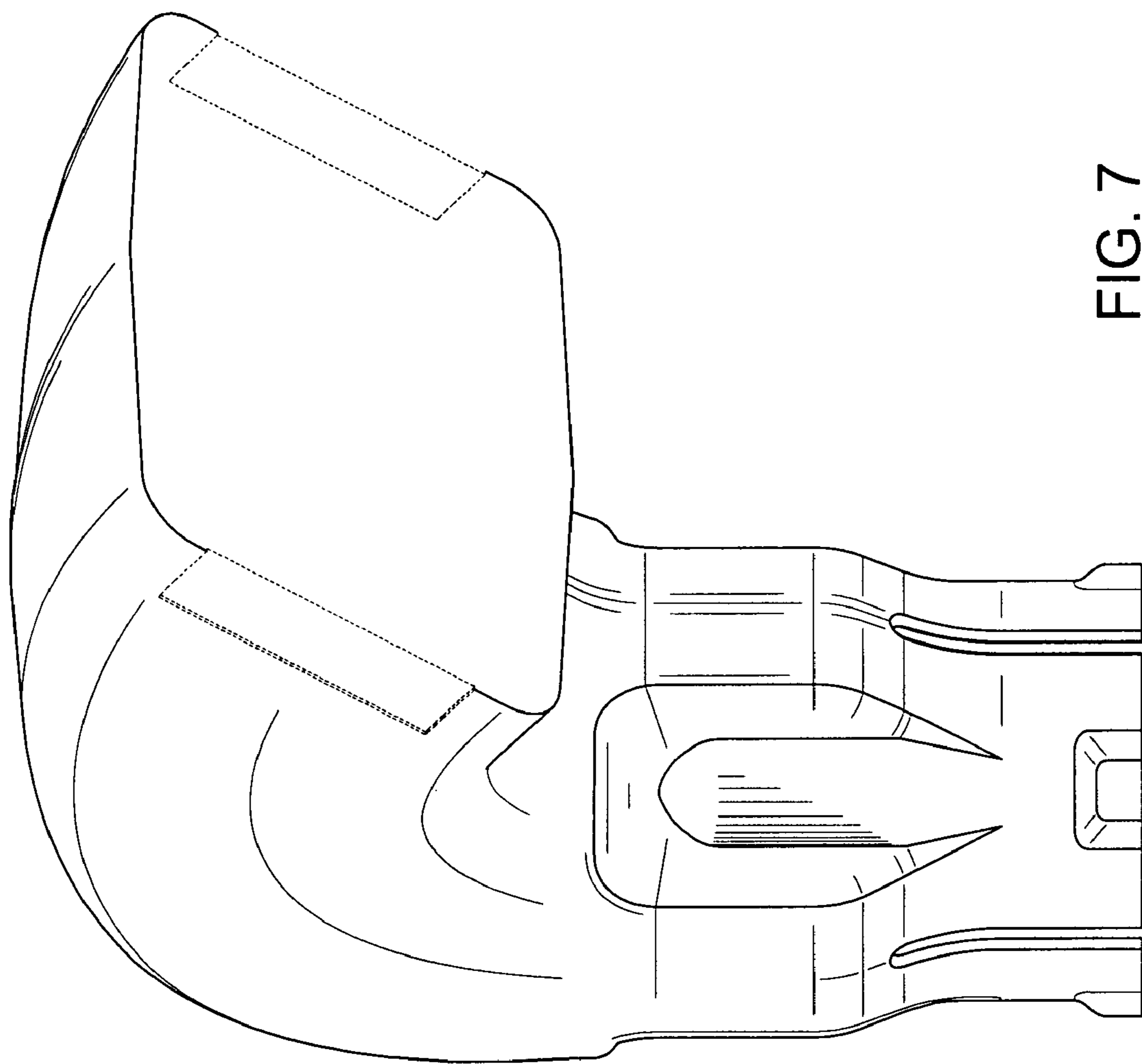

FIG. 7

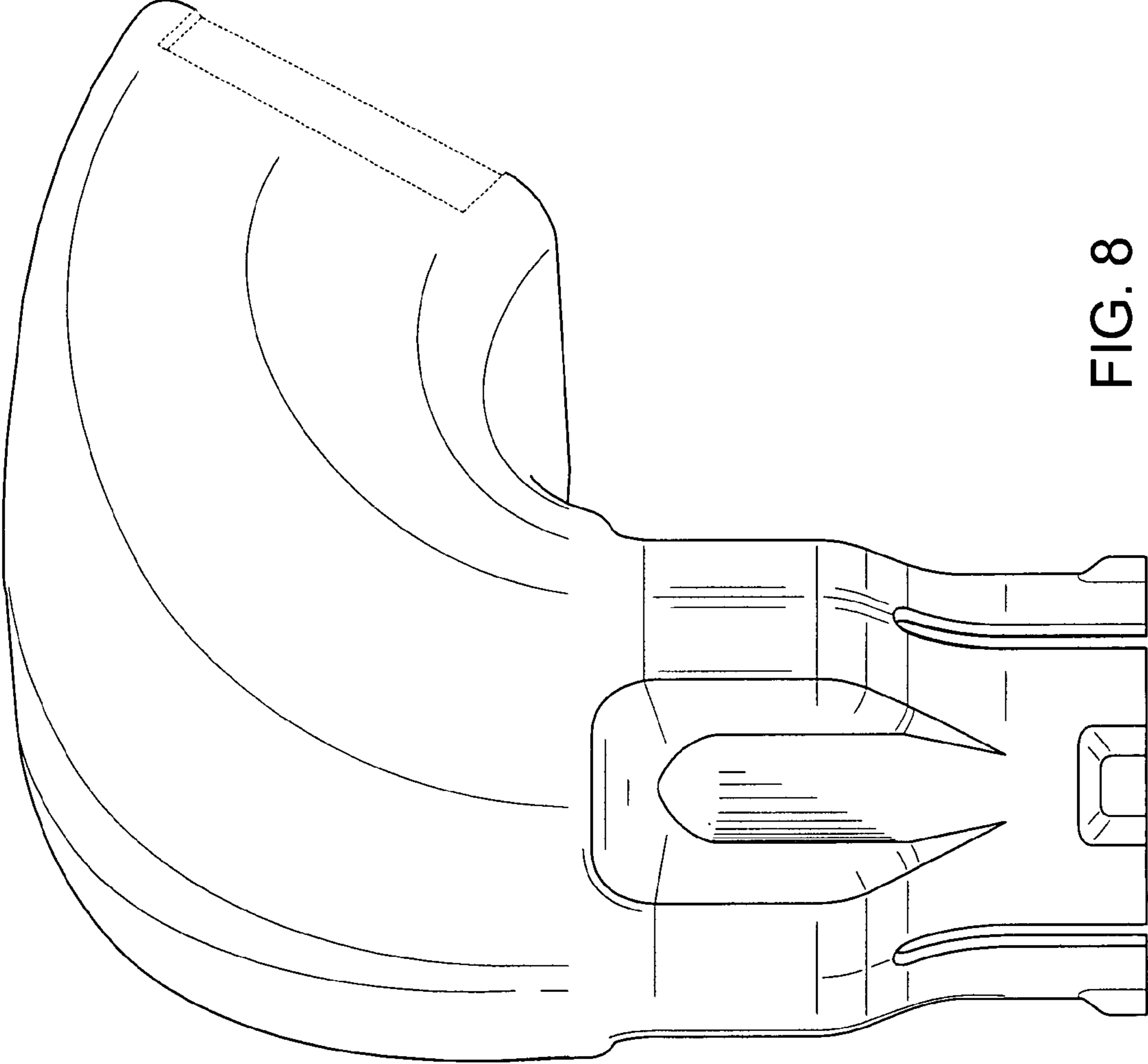

FIG. 8