



US00D637113S

(12) **United States Design Patent**
Yukawa et al.

(10) **Patent No.:** **US D637,113 S**

(45) **Date of Patent:** **** May 3, 2011**

(54) **CONVERTIBLE VEHICLE AND/OR REPLICA THEREOF**

(75) Inventors: **Mutsuo Yukawa**, Hiratsuka (JP); **Youhei Shimizu**, Zama (JP); **Kuniharu Seo**, Hiratsuka (JP)

(73) Assignee: **Nissan Motor Co., Ltd.**, Yokohama (JP)

(**) Term: **14 Years**

(21) Appl. No.: **29/380,342**

(22) Filed: **Dec. 3, 2010**

(30) **Foreign Application Priority Data**

Jun. 11, 2010 (JP) 2010-014391

(51) **LOC (9) Cl.** **12-08**

(52) **U.S. Cl.** **D12/92**

(58) **Field of Classification Search** D12/86,
D12/90-92, 88; D21/424, 433, 434; 296/181.1,
296/181.5

See application file for complete search history.

(56) **References Cited**

U.S. PATENT DOCUMENTS

D569,767 S * 5/2008 Abe et al. D12/91
D588,500 S * 3/2009 Howell et al. D12/92
D622,635 S * 8/2010 Scott et al. D12/92
D632,223 S * 2/2011 Jacob et al. D12/92

OTHER PUBLICATIONS

“Nissan 2010 Murano”, Nissan Official U.S. Media Newsroom, Image Galleries, <http://www.nissannews.com/image-gallery.do?method=view&imageGalleryId=203>, available after Sep. 2008, 2 pages.

“Nissan Murano Convertible”, BurlappCars, <http://www.burlappcars.com/2009/05/nissan-murano-convertible.html>, May 24, 2010, 2 pages.

* cited by examiner

Primary Examiner — Melody N Brown

(74) *Attorney, Agent, or Firm* — Global IP Counselors, LLP

(57) **CLAIM**

The ornamental design for a convertible vehicle and/or replica thereof, as shown and described.

DESCRIPTION

FIG. 1 is a front elevational view of a convertible vehicle and/or a replica thereof in accordance with our new design; FIG. 2 is a rear elevational view of the convertible vehicle and/or replica thereof in accordance with our new design; FIG. 3 is a top plan view of the convertible vehicle and/or replica thereof in accordance with our new design; FIG. 4 is a bottom plan view of the convertible vehicle and/or replica thereof in accordance with our new design; FIG. 5 is a right side elevational view of the convertible vehicle and/or replica thereof in accordance with our new design; FIG. 6 is a left side elevational view of the convertible vehicle and/or replica thereof in accordance with our new design; FIG. 7 is a front side perspective view of the convertible vehicle and/or replica thereof in accordance with our new design; FIG. 8 is a rear side perspective view of the convertible vehicle and/or replica thereof in accordance with our new design; FIG. 9 is a front side perspective view of the convertible vehicle and/or replica thereof in accordance with our new design with a roof portion being shown in broken line to indicate a state in which the roof portion is folded away; FIG. 10 is a rear side perspective view of the convertible vehicle and/or replica thereof in accordance with our new design with the roof portion being shown in broken line to indicate a state in which the roof portion is folded away; and, FIG. 11 is a top plan view of the convertible vehicle and/or replica thereof in accordance with our new design with the roof portion being shown in broken line to indicate a state in which the roof portion is folded away. The broken line showing of the convertible vehicle and/or replica thereof is for purpose of illustrating environmental structure and forms no part of the claimed design.

1 Claim, 10 Drawing Sheets

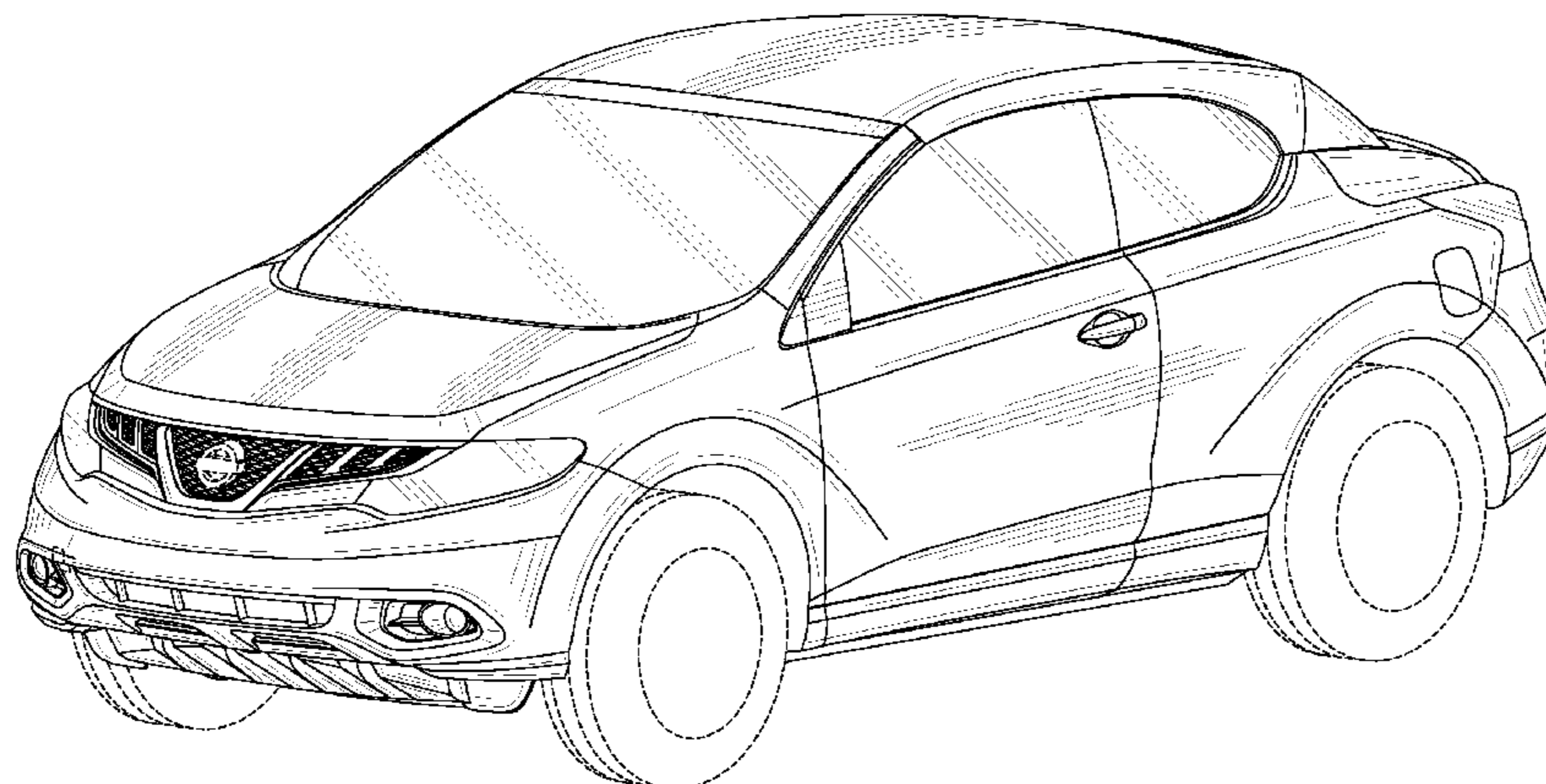

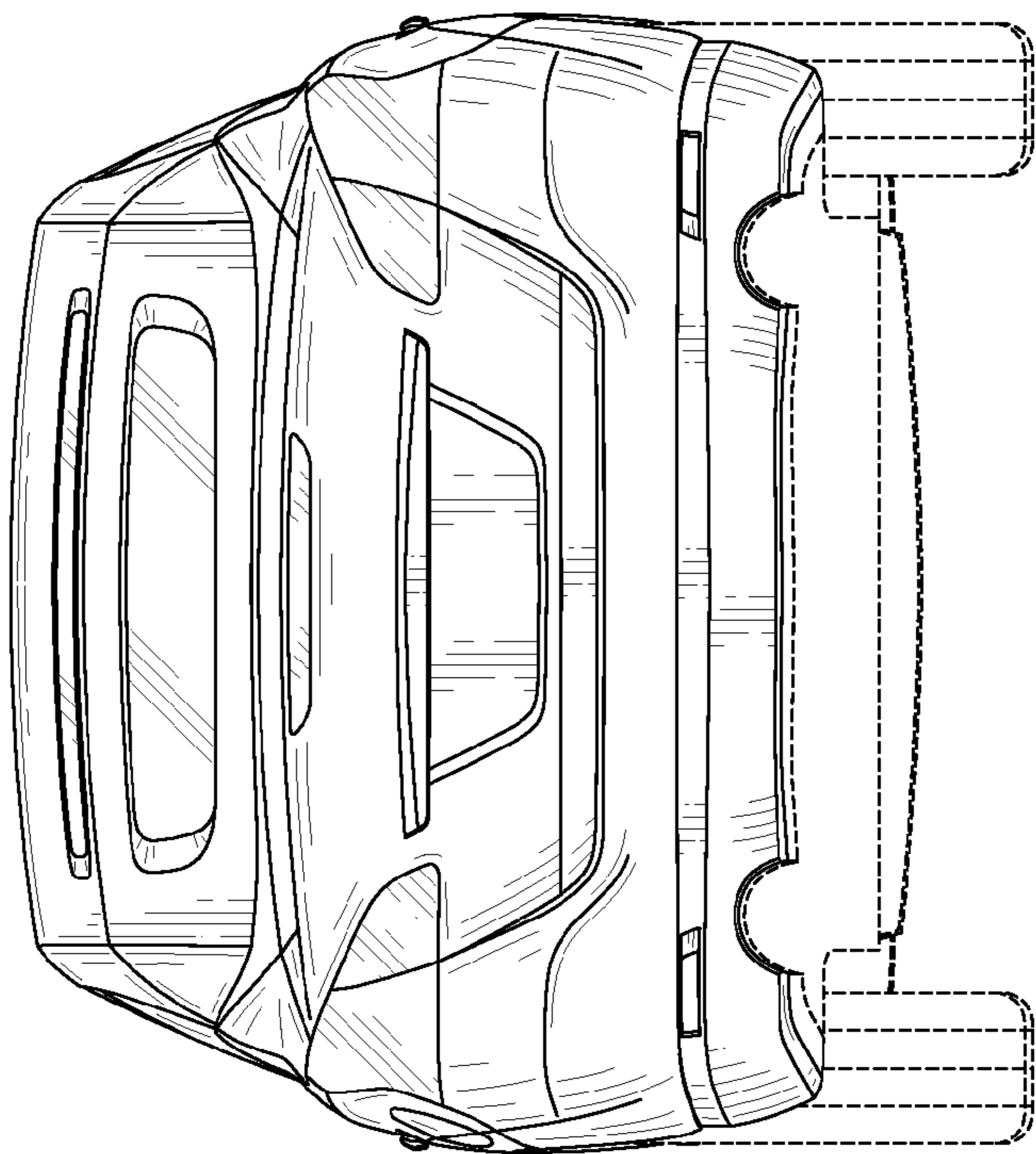

FIG. 1

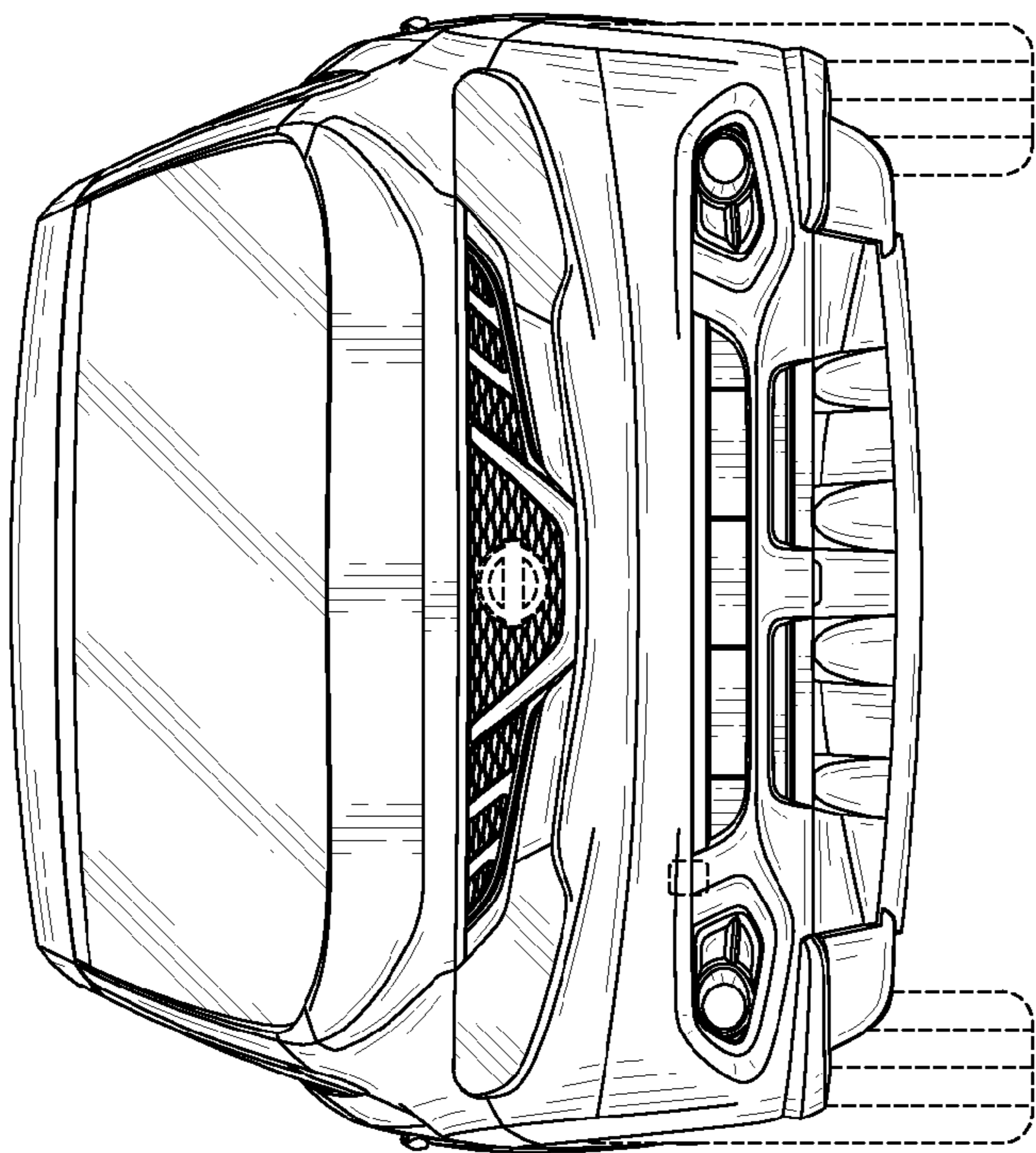

FIG. 2

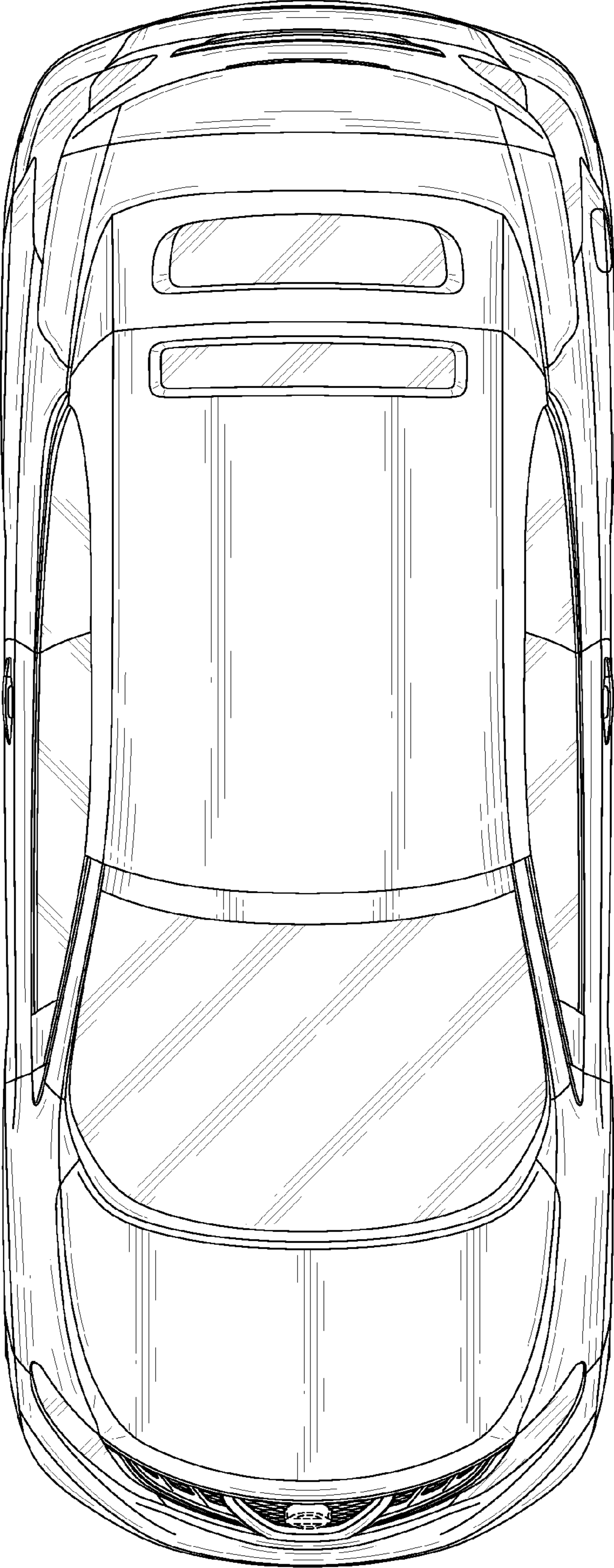

FIG. 3

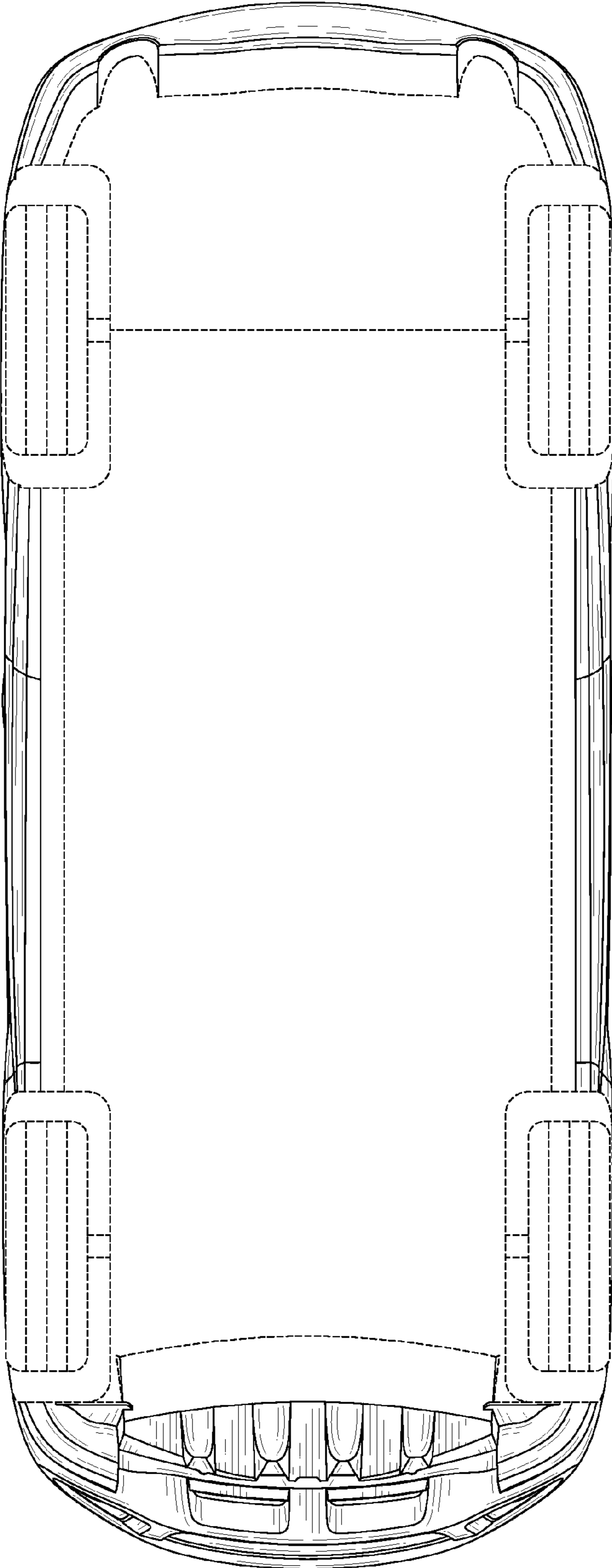

FIG. 4

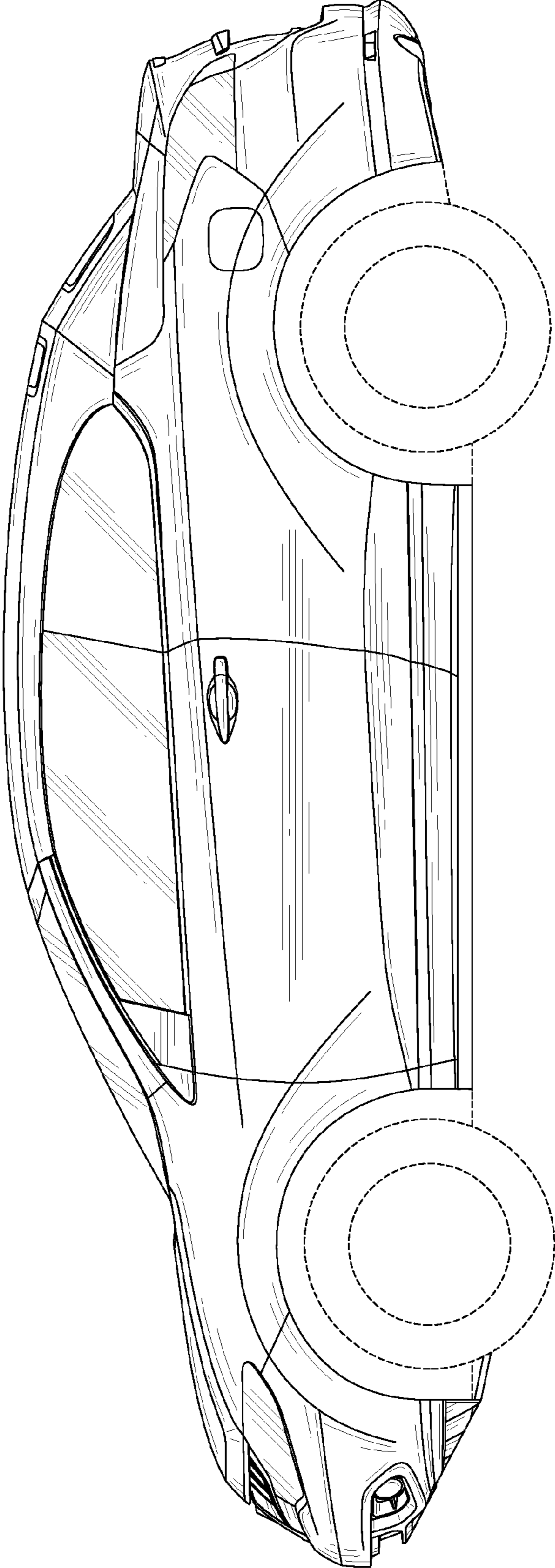

FIG. 5

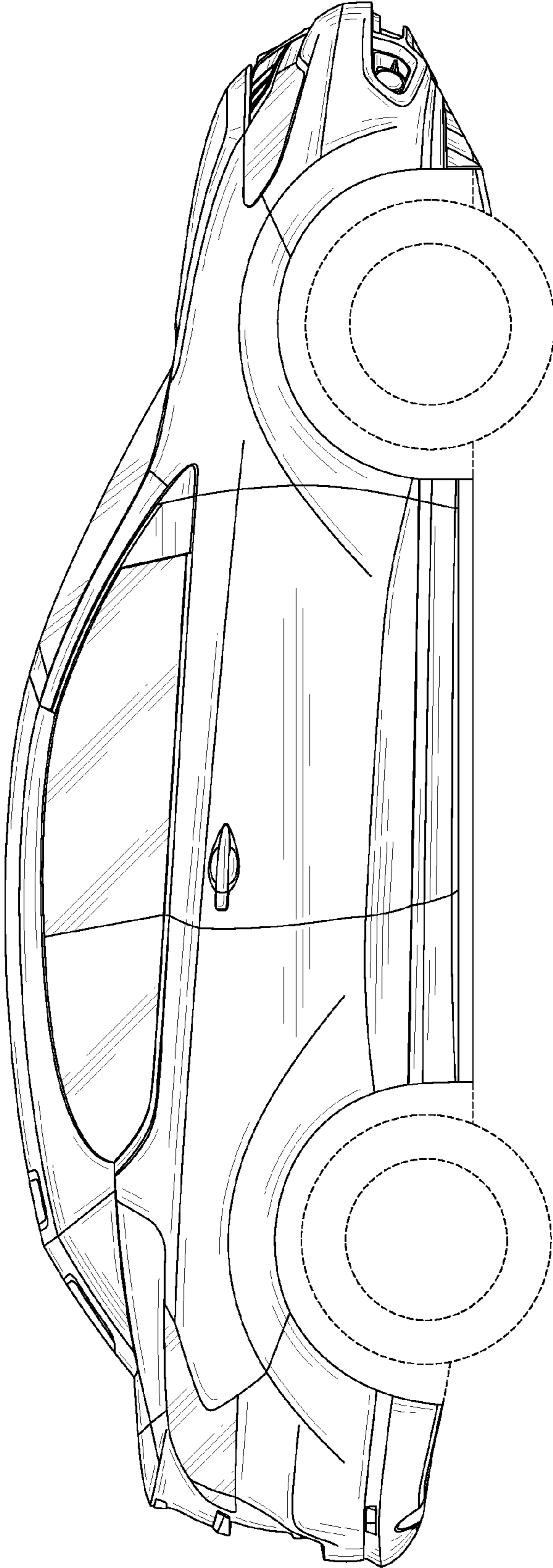

FIG. 6

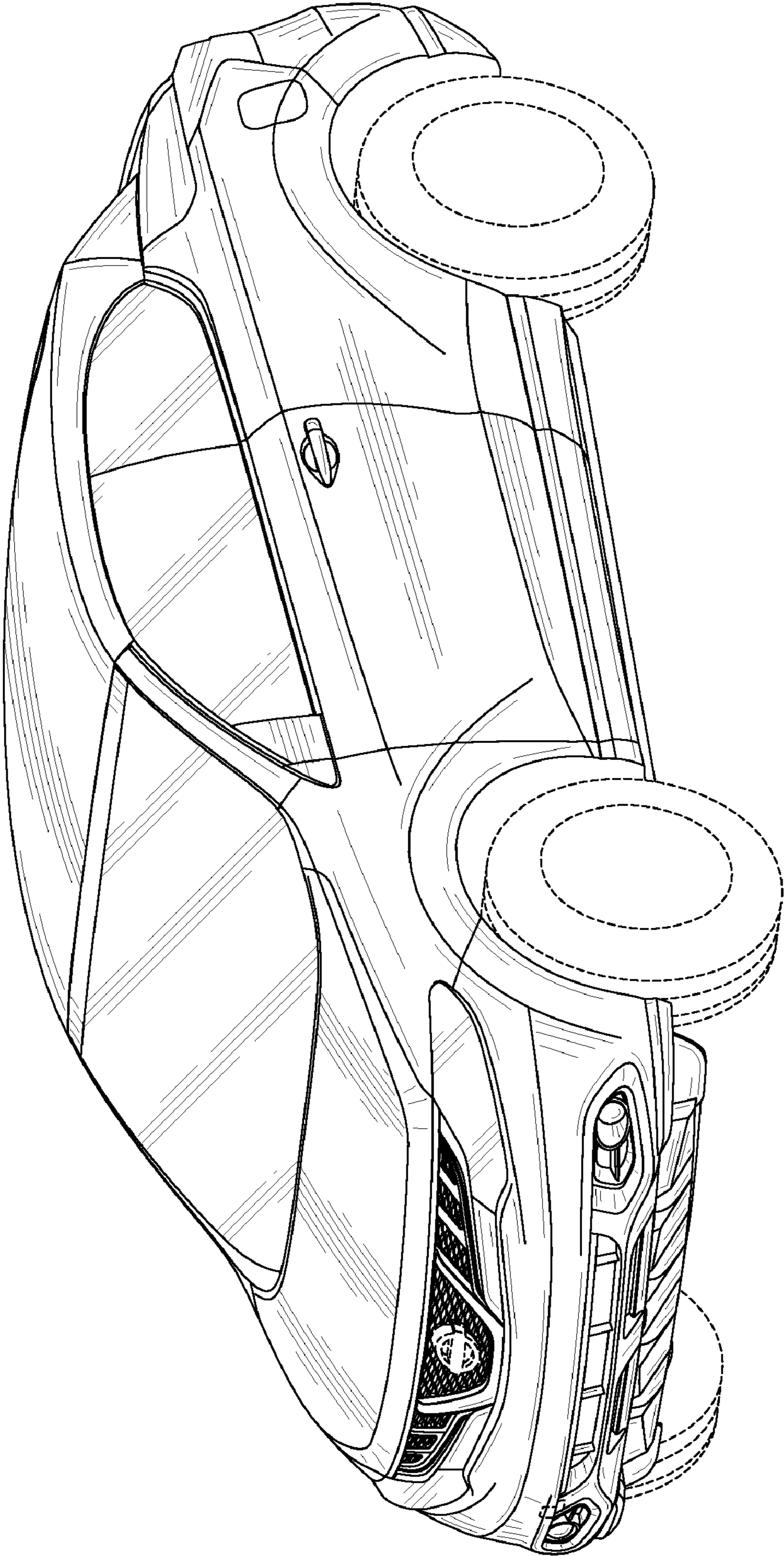

FIG. 7

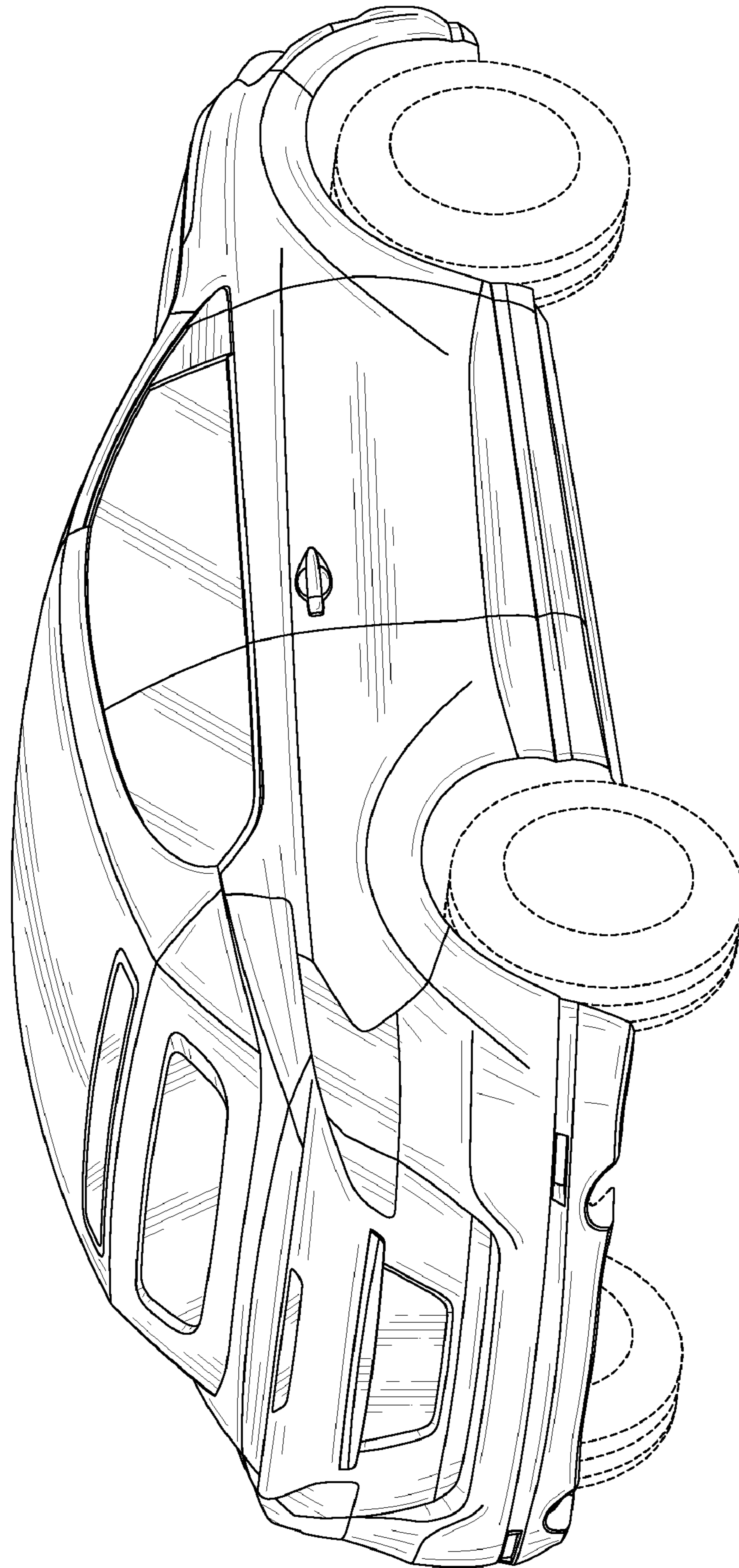

FIG. 8

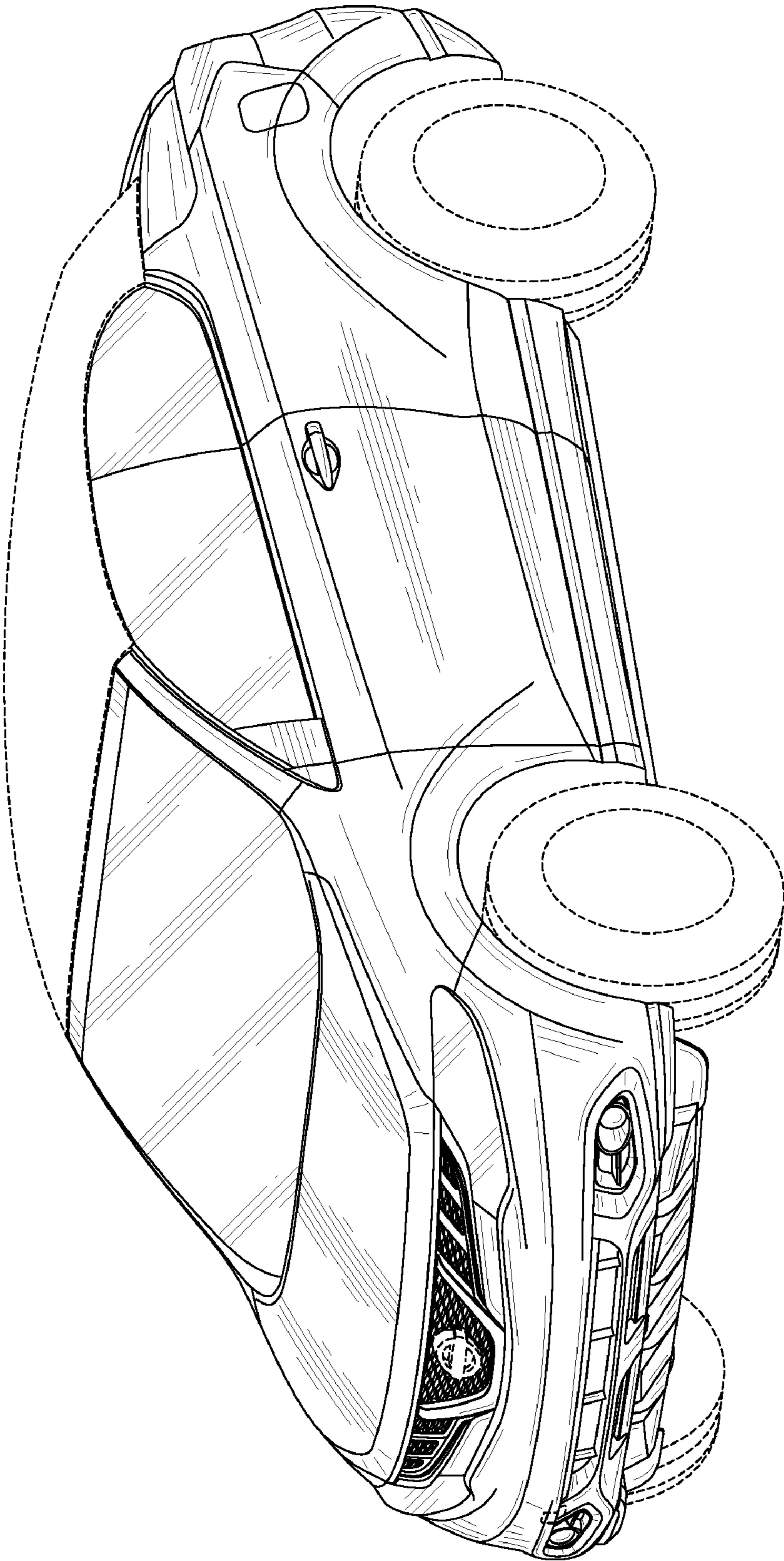

FIG. 9

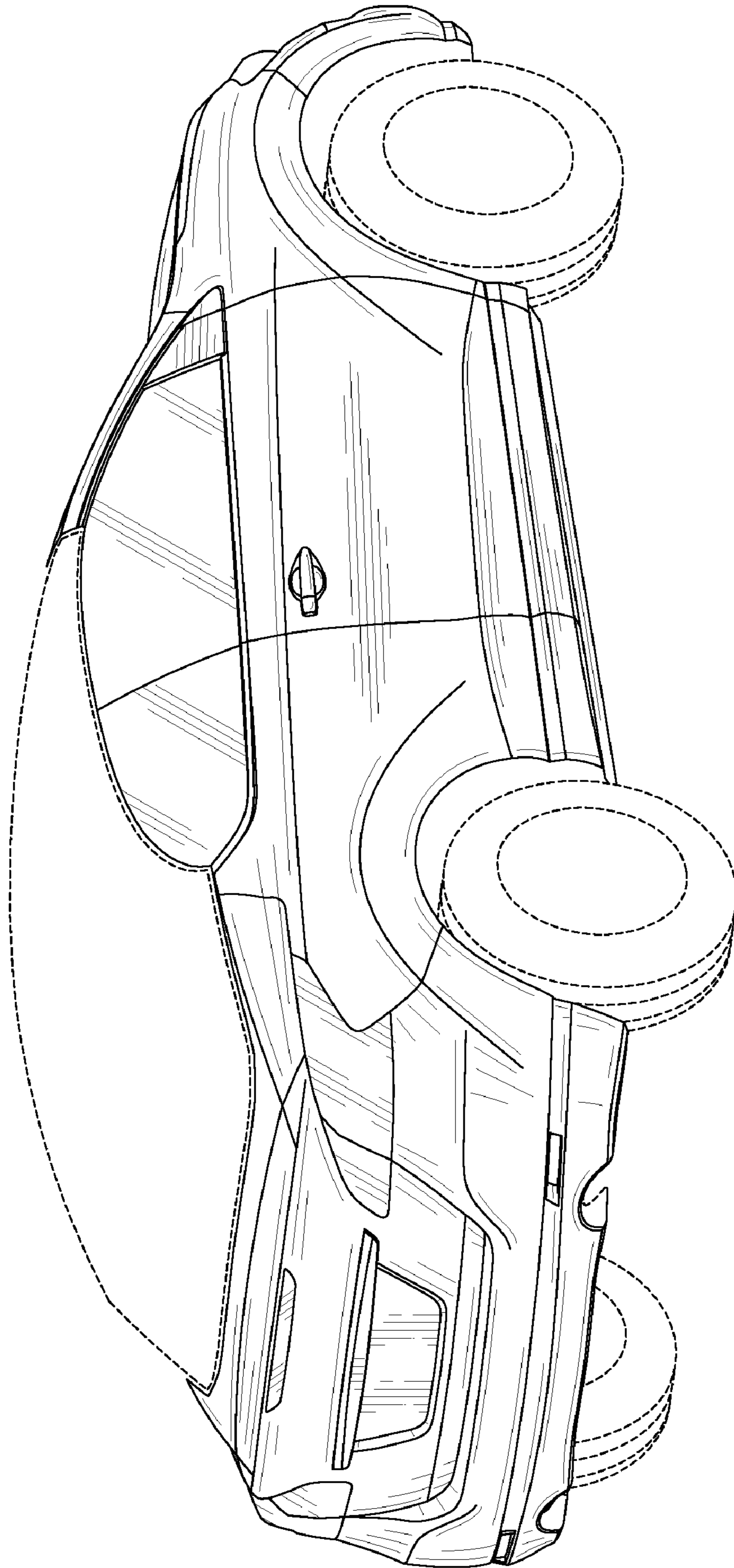

FIG. 10

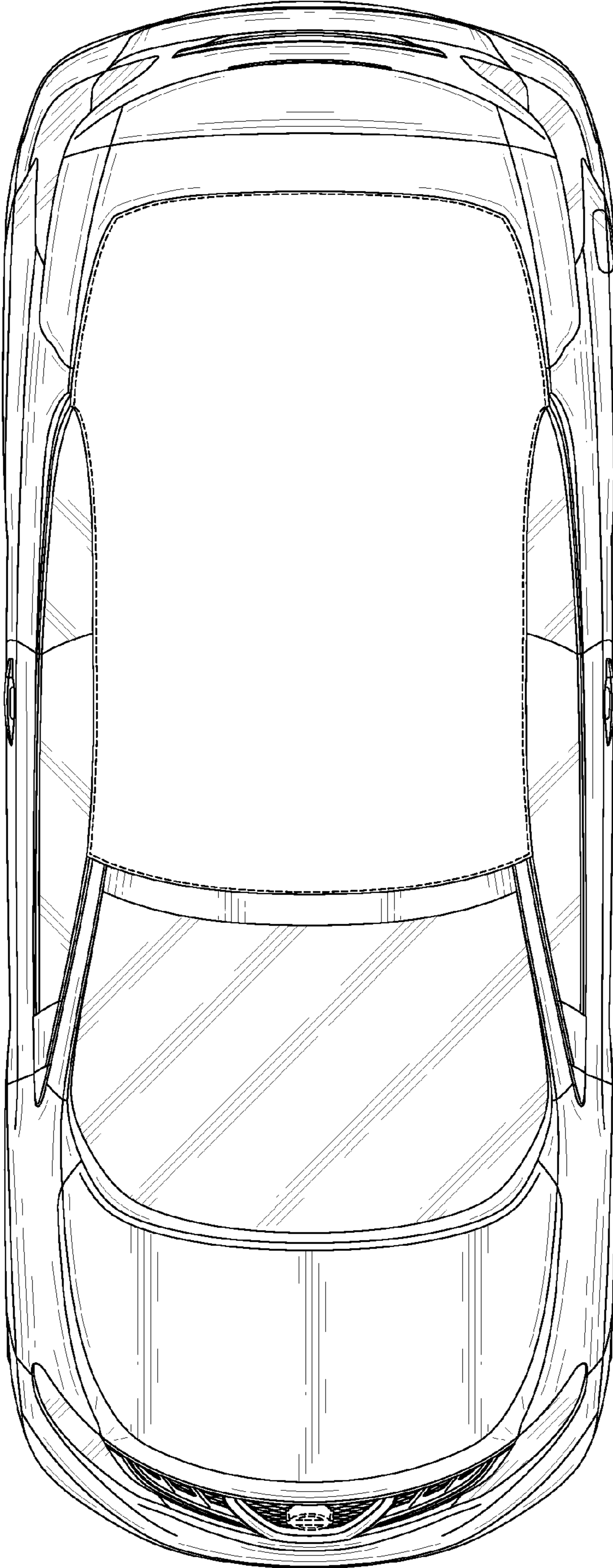

FIG. 11