



US00D637067S

(12) **United States Design Patent**
Bauck et al.

(10) **Patent No.:** **US D637,067 S**

(45) **Date of Patent:** **** *May 3, 2011**

(54) **HOSE REEL**

248/636; 242/532.6, 530.3, 476.6, 118.6;
160/315; 137/355.26, 355.2, 355.16

See application file for complete search history.

(75) Inventors: **Mark L. Bauck**, Coon Rapids, MN (US); **Zaixing You**, Phenix (CN); **Lihui Gao**, PingJiang District (CN); **Xueshui Wu**, Pnenix (CN); **Jin Tian**, Can Lang Borough (CN); **Brian J. Zumbolo**, Lino Lakes, MN (US); **Anthony J. Gargano**, Savage, MN (US); **Scott F. Hill**, Maple Grove, MN (US); **Qing Fu**, Shanghai (CN); **Wade D. Palashewski**, Andover, MN (US); **Thomas R. Larson**, Elk River, MN (US)

(56) **References Cited**

U.S. PATENT DOCUMENTS

D491,444 S * 6/2004 Nicholls D8/358
D595,121 S * 6/2009 Murphy D8/358

OTHER PUBLICATIONS

Duro Reel photograph from website, Feb. 25, 2010.
Reecraft photograph from website, Feb. 25, 2010.

* cited by examiner

Primary Examiner — Susan Bennett Hattan

(74) *Attorney, Agent, or Firm* — Douglas B. Farrow

(73) Assignee: **Graco Minnesota Inc.**, Minneapolis, MN (US)

(*) Notice: This patent is subject to a terminal disclaimer.

(57) **CLAIM**

The ornamental design for the hose reel, as shown and described.

(**) Term: **14 Years**

DESCRIPTION

(21) Appl. No.: **29/346,305**

FIG. 1 is a front perspective view of the hose reel;
FIG. 2 is a top elevation view thereof;
FIG. 3 is a left side elevation view thereof;
FIG. 4 is a front elevation view thereof;
FIG. 5 is a rear elevation view thereof;
FIG. 6 is a right side elevation view thereof; and,
FIG. 7 is a bottom elevation view thereof.

(22) Filed: **Oct. 29, 2009**

(51) **LOC (9) Cl.** **08-05**

(52) **U.S. Cl.** **D8/358**

(58) **Field of Classification Search** D8/360,
D8/359, 358; D3/24; D15/5, 199, 147, 138;
474/7, 66, 47-53, 29, 198, 196, 161; 248/638,

1 Claim, 7 Drawing Sheets

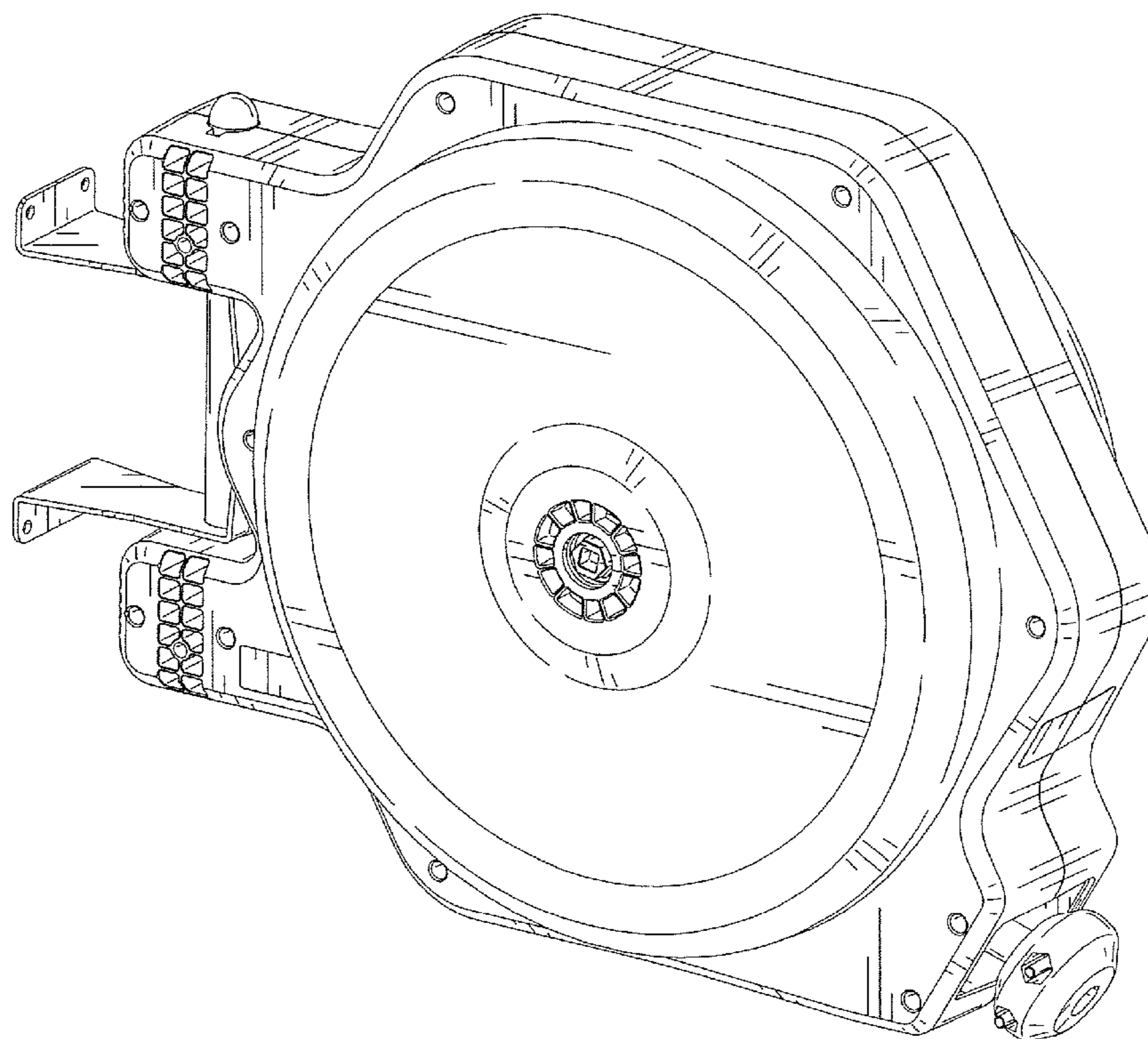

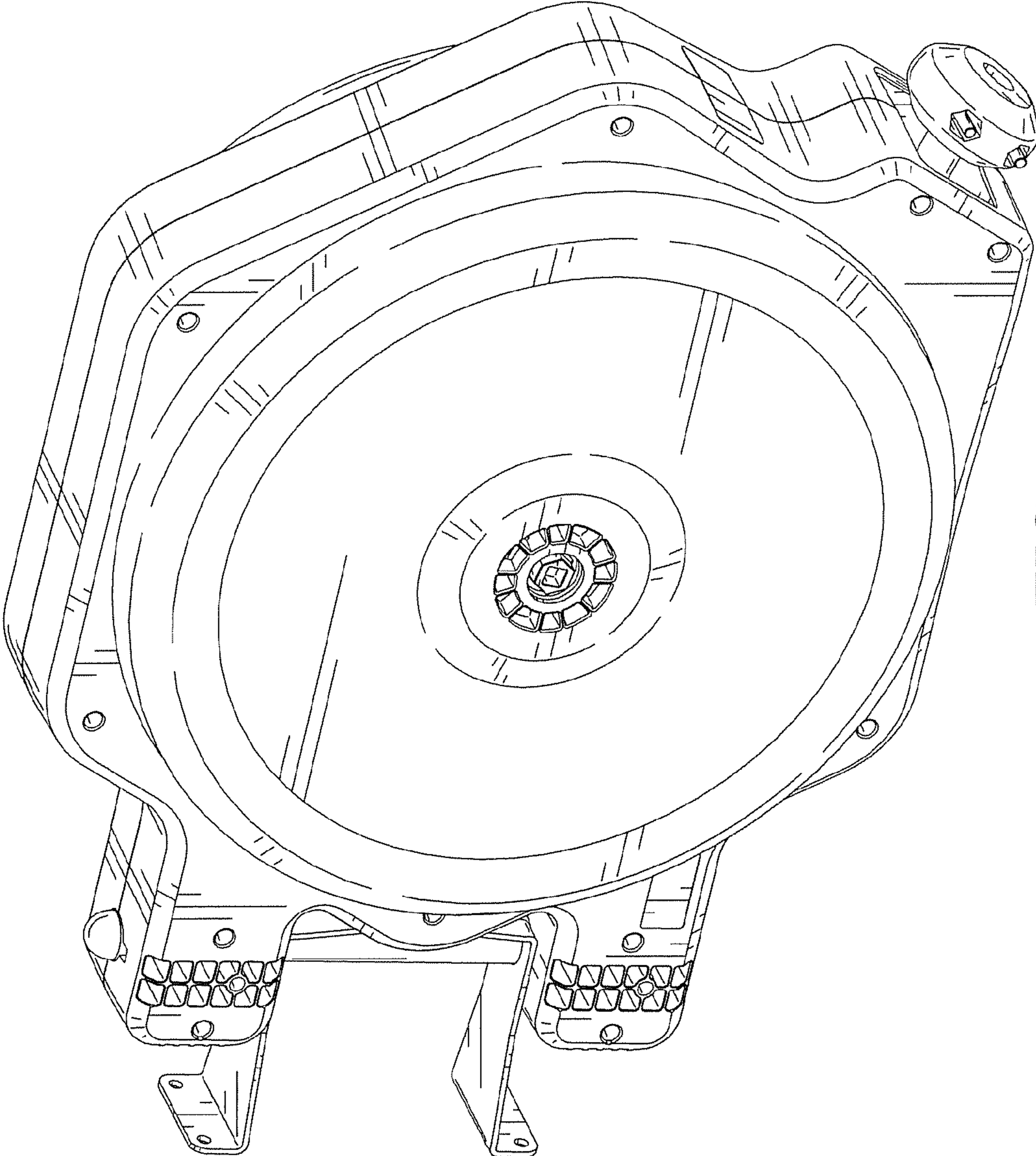

FIG. 1



FIG. 2

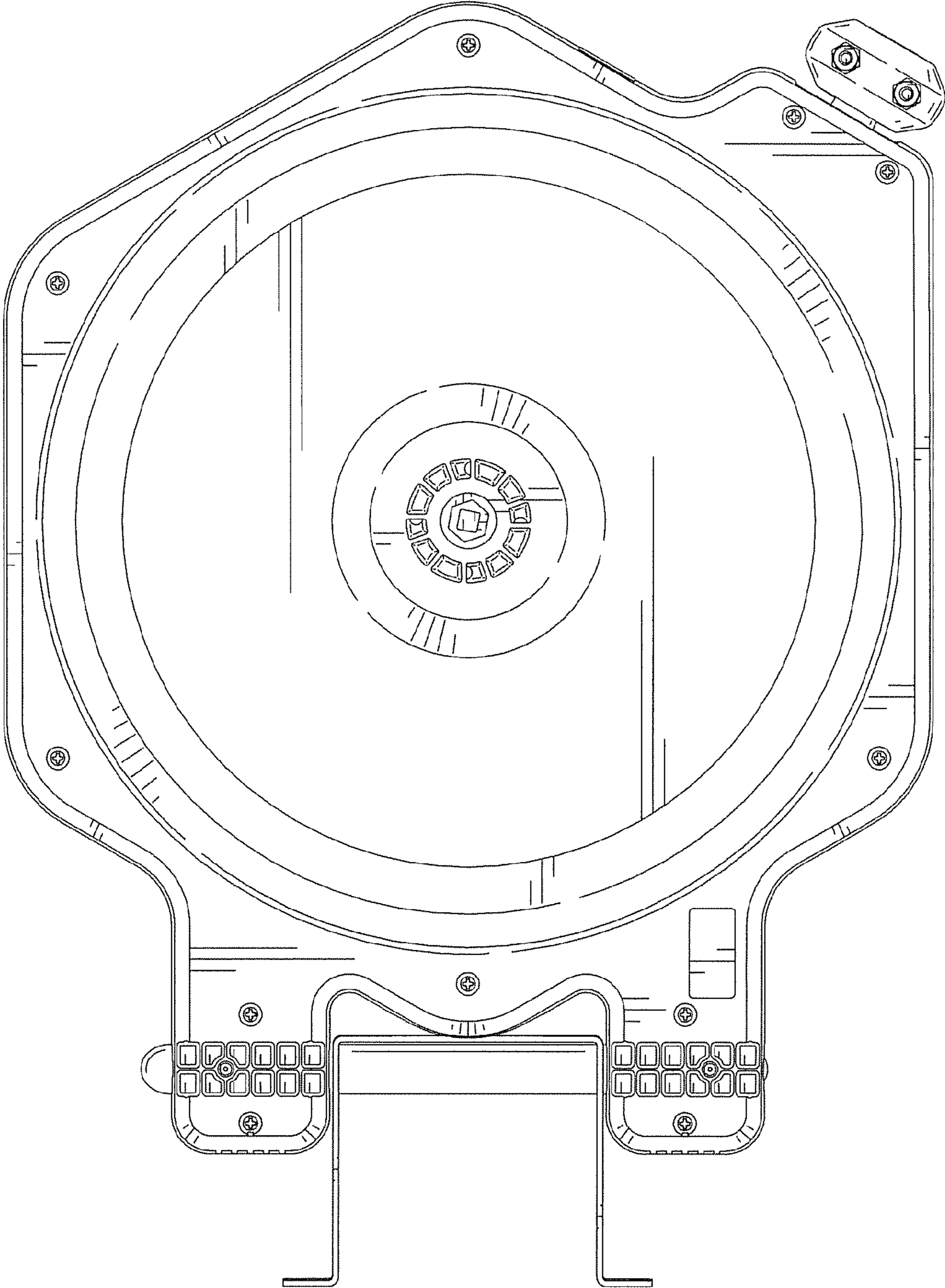

FIG. 3

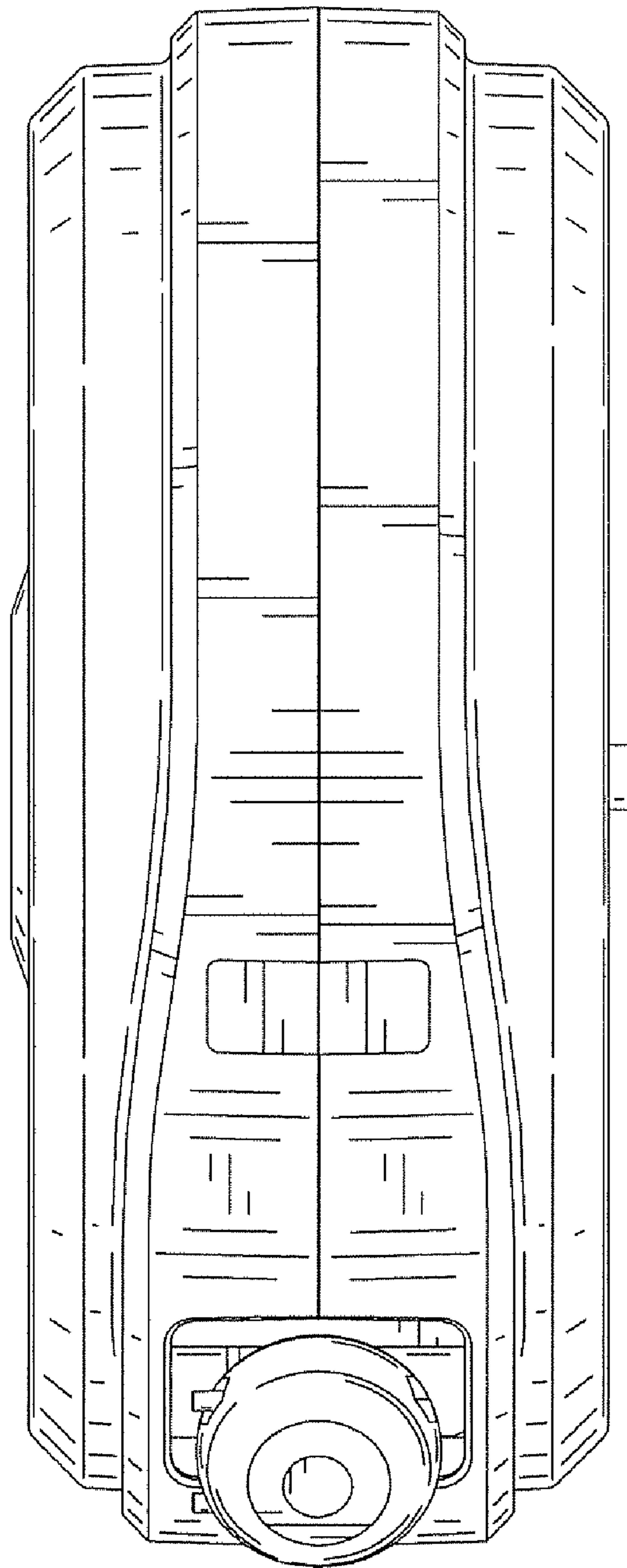

FIG. 4

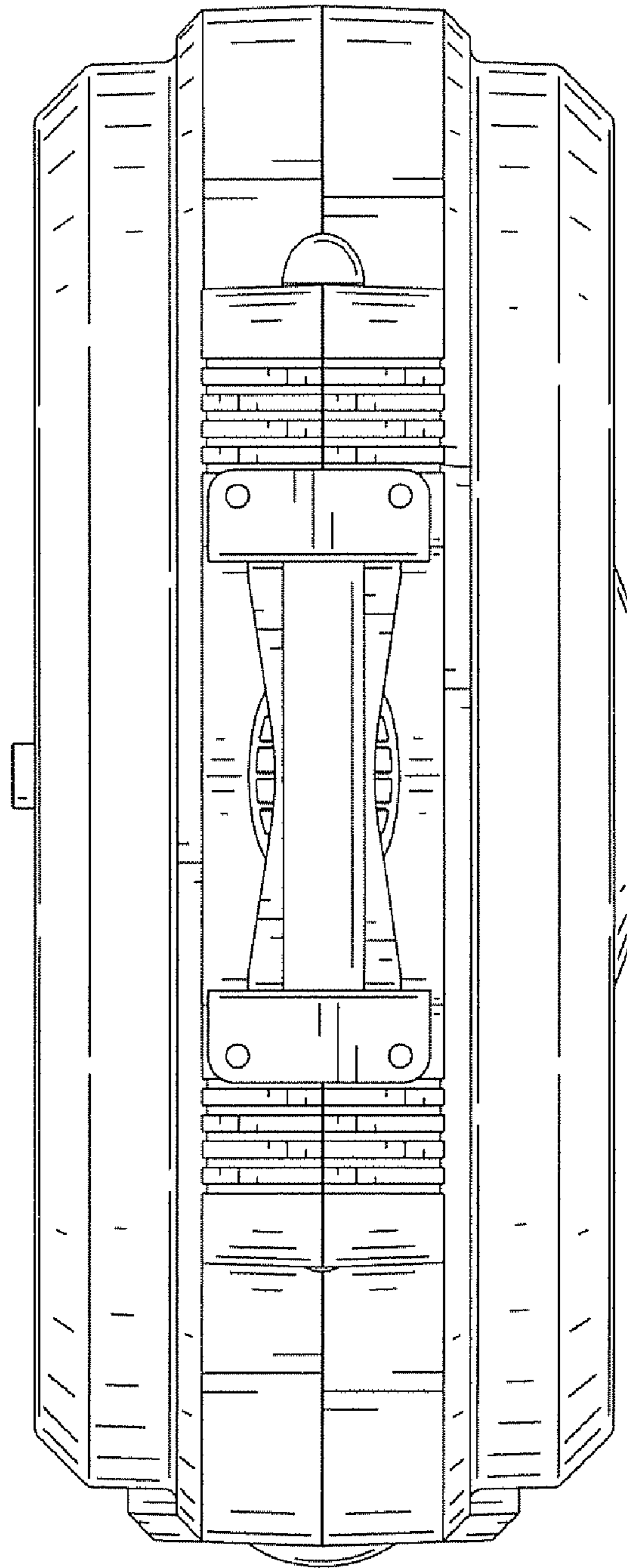

FIG. 5

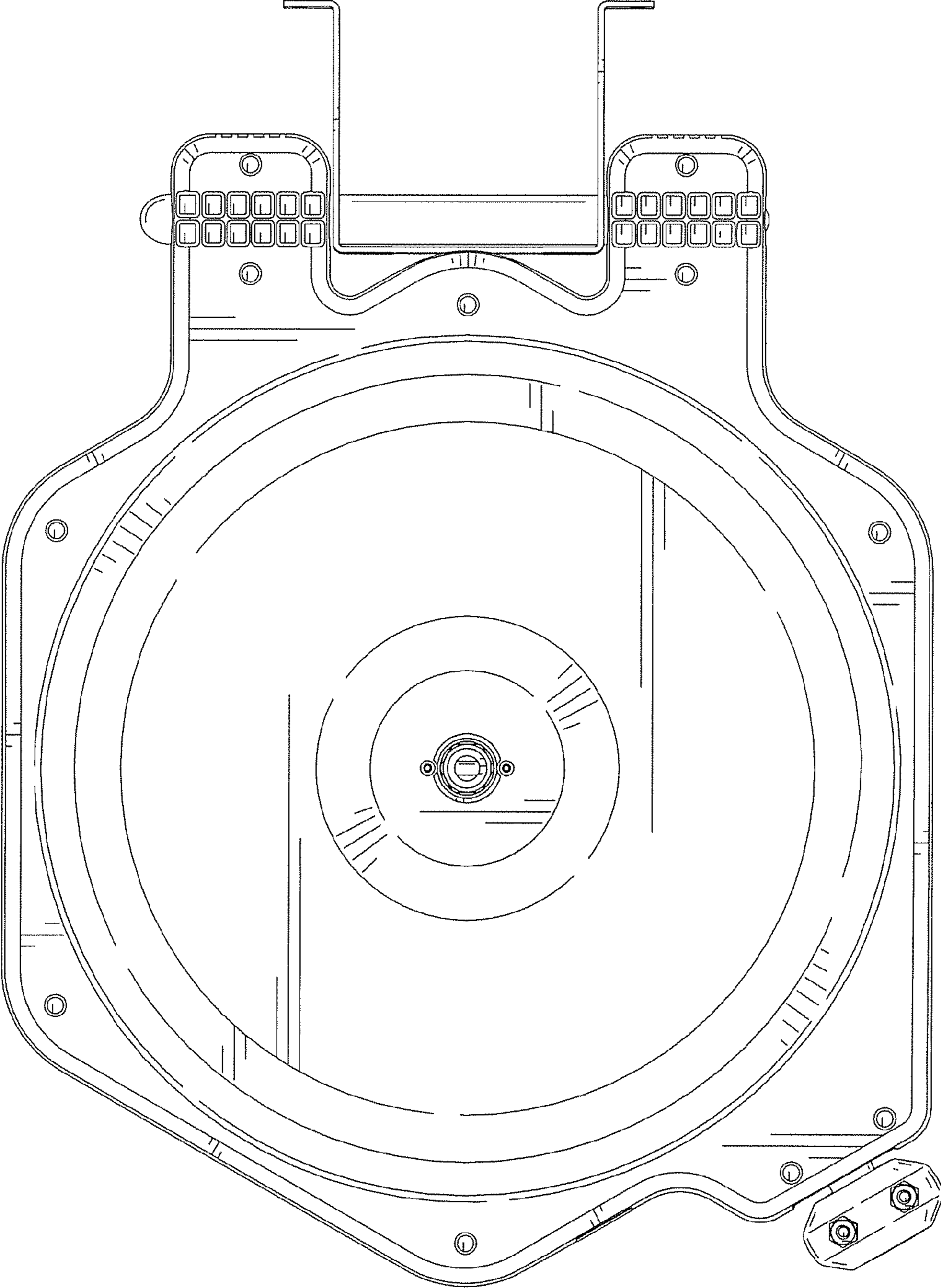

FIG. 6



FIG. 7