



US00D637064S

(12) **United States Design Patent**
Singtoroj

(10) **Patent No.:** **US D637,064 S**

(45) **Date of Patent:** **** May 3, 2011**

(54) **DEADBOLT INTERIOR**

(75) Inventor: **Yos Singtoroj**, Anaheim, CA (US)

(73) Assignee: **Newfrey LLC**, Newark, DE (US)

(**) Term: **14 Years**

(21) Appl. No.: **29/368,860**

(22) Filed: **Aug. 31, 2010**

(51) **LOC (9) Cl.** **11-05**

(52) **U.S. Cl.** **D8/350; D8/330**

(58) **Field of Classification Search** D8/350–353,
D8/330, 331, 346, 302, 341, 343, 338; D23/254,
D23/249; 174/66; 292/347, 357, DIG. 37;
70/271, 277, 278.1, 284, 278.4, 285, 450;
340/5.21, 5.54, 5.65, 5.73, 5.81, 5.85
See application file for complete search history.

(56) **References Cited**

U.S. PATENT DOCUMENTS

D365,976 S *	1/1996	Chiu	D8/330
D411,732 S *	6/1999	Chamberlain	D8/350
D429,142 S *	8/2000	Monge et al.	D8/350
D435,288 S *	12/2000	Milrud et al.	D23/254
D437,771 S *	2/2001	Barnes et al.	D8/352
D470,033 S *	2/2003	Fleury et al.	D8/302
D472,794 S *	4/2003	LaPlume et al.	D8/350
D503,329 S *	3/2005	Berberet	D8/350
D513,469 S *	1/2006	Gao et al.	D8/350

D552,966 S *	10/2007	Roberts et al.	D8/350
D552,967 S *	10/2007	Roberts et al.	D8/350
D552,968 S *	10/2007	Roberts et al.	D8/350
D553,953 S *	10/2007	Roberts et al.	D8/350
D578,866 S *	10/2008	Kim	D8/353
D579,312 S *	10/2008	Veltz	D8/330
D588,439 S *	3/2009	Lin et al.	D8/350
D592,936 S *	5/2009	Douglas et al.	D8/350
D593,399 S *	6/2009	Douglas et al.	D8/350
D597,821 S *	8/2009	Nunez et al.	D8/350

* cited by examiner

Primary Examiner — Mark A Goodwin

(74) *Attorney, Agent, or Firm* — Richard J. Veltman; John D. DelPonti

(57) **CLAIM**

The ornamental design for a deadbolt interior, as shown and described.

DESCRIPTION

FIG. 1 is a perspective view of a deadbolt interior showing a new design;

FIG. 2 is a reduced front view thereof;

FIG. 3 is a back view thereof;

FIG. 4 is a top view thereof;

FIG. 5 is a bottom view thereof; and,

FIG. 6 is a right side view thereof, the left side view thereof being a mirror image.

The broken lines in the Figures are for illustrative purposes only and form no part of the claimed design.

1 Claim, 4 Drawing Sheets

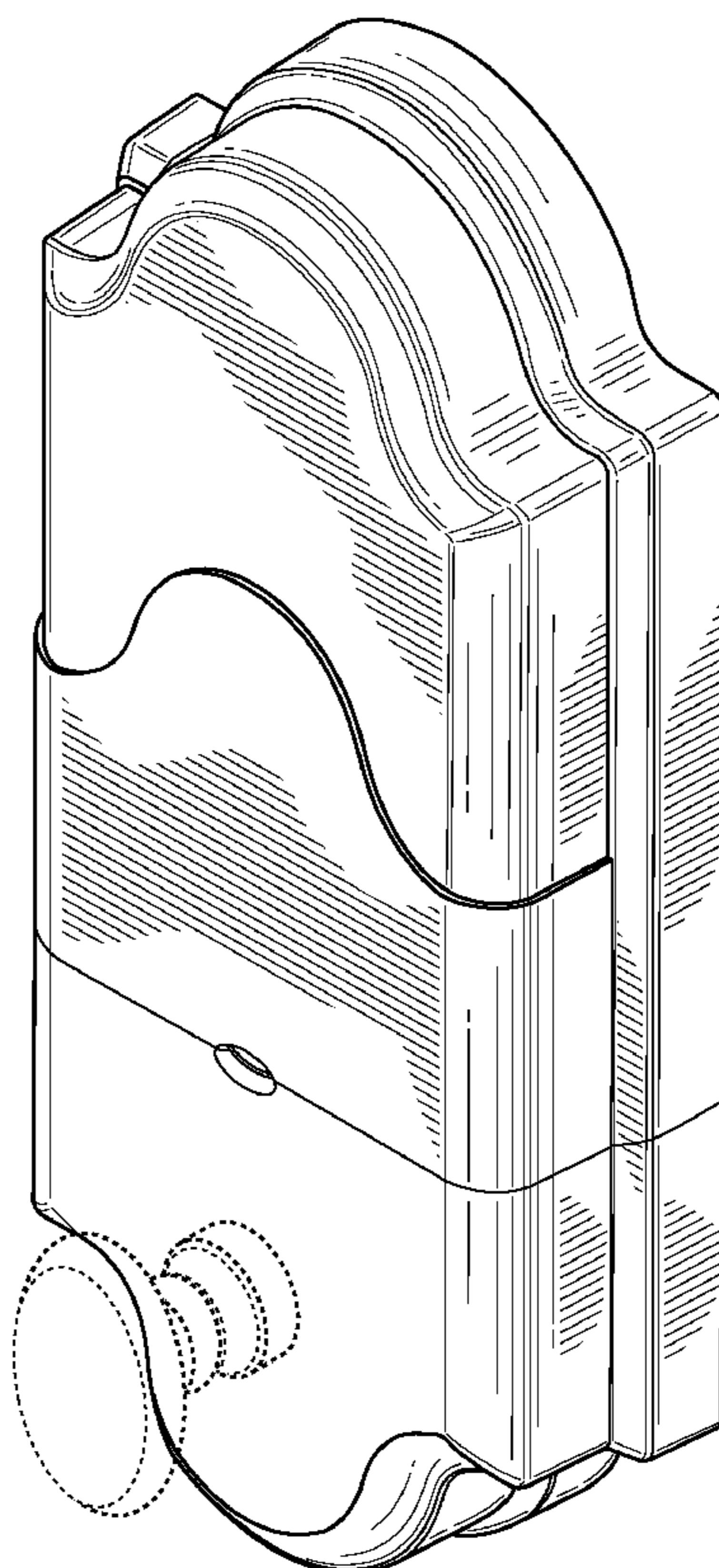

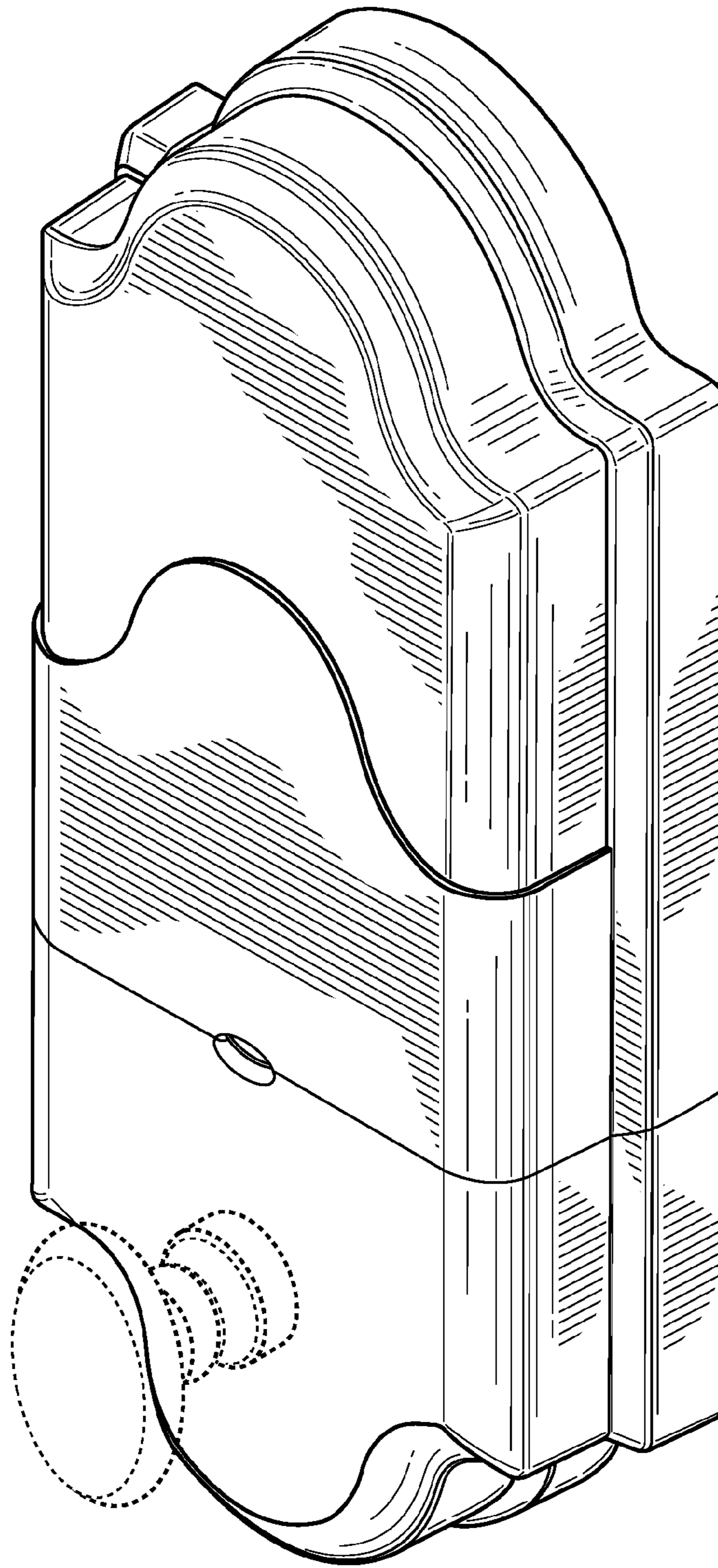

FIG. 1

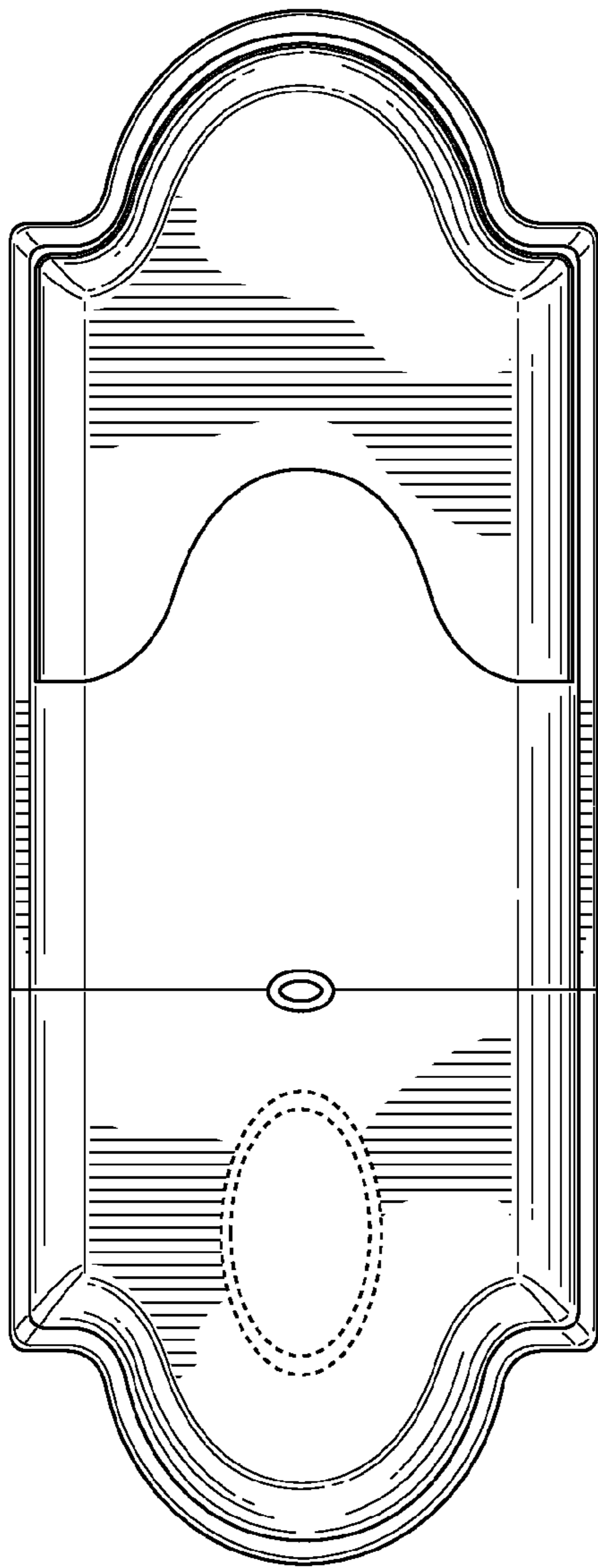

FIG. 2

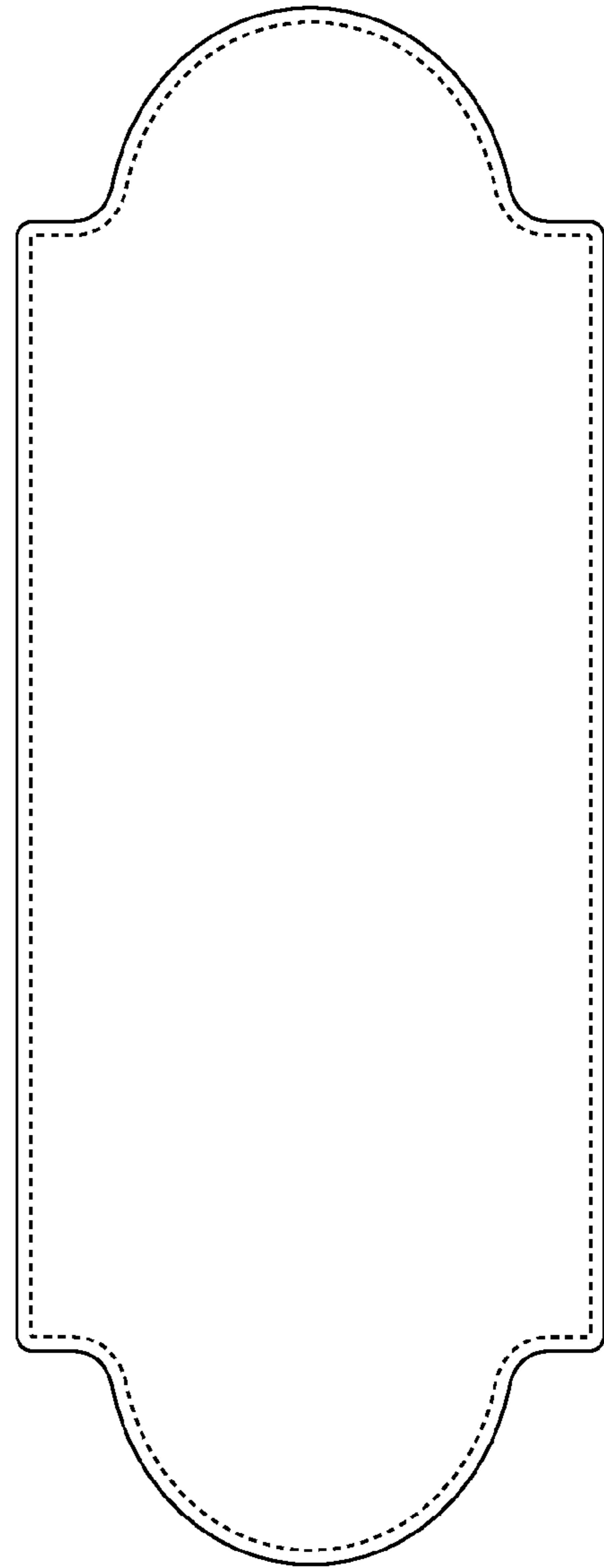

FIG. 3

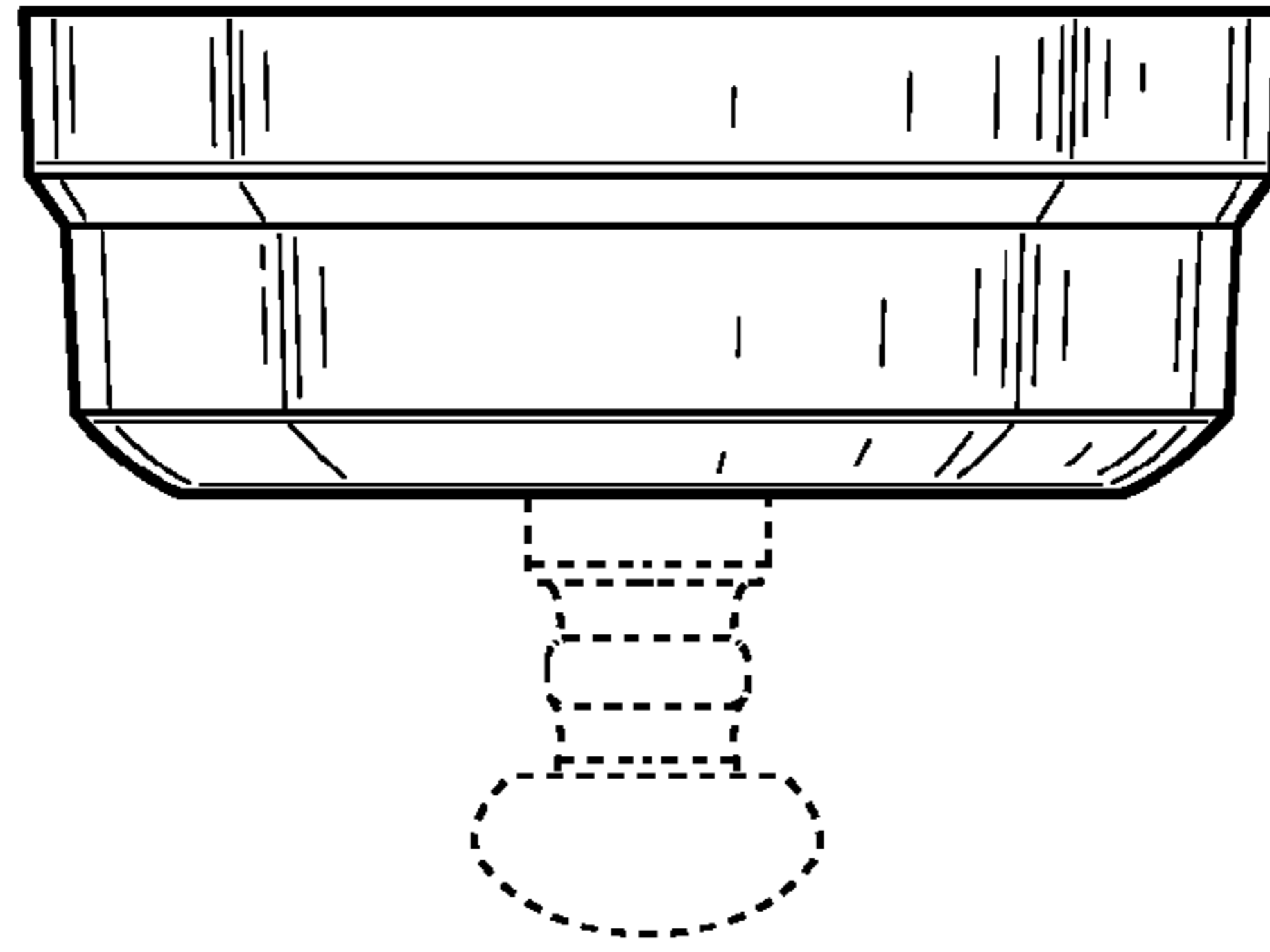

FIG. 4

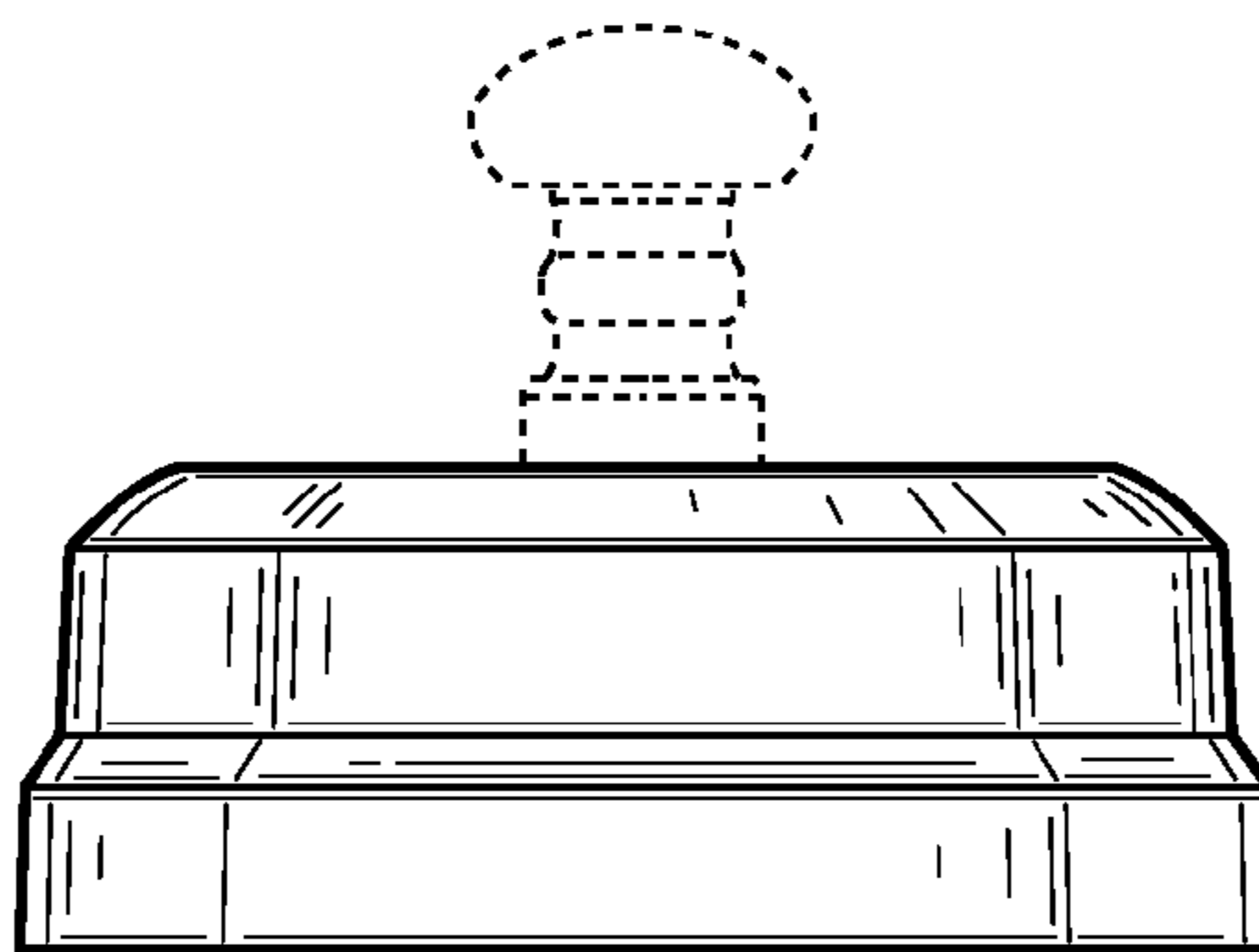

FIG. 5

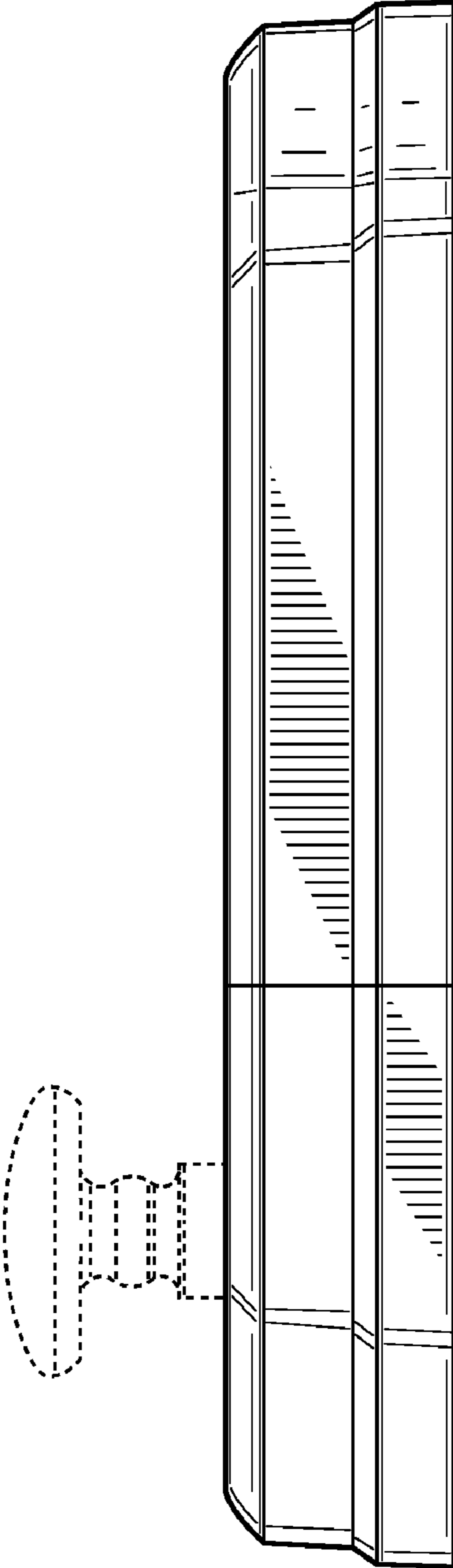

FIG. 6