



US00D636718S

(12) **United States Design Patent**
Naef

(10) **Patent No.:** **US D636,718 S**

(45) **Date of Patent:** **** Apr. 26, 2011**

(54) **ROOF OF BUS**

(75) Inventor: **Alex Naef**, Bellach (CH)

(73) Assignee: **Carrosserie Hess AG**, Bellach (CH)

(**) Term: **14 Years**

(21) Appl. No.: **29/366,401**

(22) Filed: **Jul. 23, 2010**

(30) **Foreign Application Priority Data**

Jun. 16, 2010 (CH) DM/073 754

(51) **LOC (9) Cl.** **12-16**

(52) **U.S. Cl.** **D12/404**

(58) **Field of Classification Search** D12/401-414,
D12/414.1, 89-93, 16, 96-100; D21/433-434,
D21/548, 552, 559, 561; D25/38, 43; D6/552,
D6/513, 567; 135/88.01, 95, 165-167; 150/158;
160/32, 26; 280/770; 296/136.01, 190.08,
296/190.01-190.02, 114-116, 77.1, 100.01-100.06,
296/98; 248/687, 688; D8/71; D3/905,
D3/272, 273; 5/662

See application file for complete search history.

(56) **References Cited**

U.S. PATENT DOCUMENTS

D362,423	S *	9/1995	Thomas, Jr.	D12/401
6,056,352	A *	5/2000	Ewing et al.	296/214
6,129,413	A *	10/2000	Klein	296/220.01
D514,056	S *	1/2006	Nadeau	D12/401
D586,721	S *	2/2009	Hildebrand et al.	D12/401
D620,877	S *	8/2010	Rusher et al.	D12/401
D625,680	S *	10/2010	de Waal	D12/404
2002/0030388	A1 *	3/2002	Pfalzgraf et al.	296/220.01
2002/0053811	A1 *	5/2002	Myers	296/100.02
2003/0168878	A1 *	9/2003	Myers	296/100.02
2004/0135393	A1 *	7/2004	Neuer et al.	296/136.1
2006/0208524	A1 *	9/2006	Brown et al.	296/100.01
2007/0035151	A1 *	2/2007	Rusu	296/100.01

(Continued)

Primary Examiner — Caron Veynar

Assistant Examiner — Katrina A Kile

(74) *Attorney, Agent, or Firm* — Birch, Stewart, Kolasch & Birch, LLP

(57) **CLAIM**

The ornamental design for a roof of bus, as shown and described.

DESCRIPTION

FIG. 1 is a front view of a first embodiment of my new design; FIG. 2 is a right side view of the first embodiment; FIG. 3 is a left side view of the first embodiment; FIG. 4 is a rear view of the first embodiment; FIG. 5 is a top view of the embodiment; FIG. 6 is a right-side elevated perspective view of the first embodiment; FIG. 7 is a left-side elevated perspective view of the first embodiment; FIG. 8 is a right-rear elevated perspective view of the first embodiment; FIG. 9 is an example showing a front view of the first embodiment mounted on a bus; FIG. 10 is an example showing a right side view of the first embodiment mounted on the bus; FIG. 11 is an example showing a left side view of the first embodiment mounted on the bus; FIG. 12 is an example showing a rear view of the first embodiment mounted on the bus; FIG. 13 is an example of a top view of the first embodiment mounted on the bus; FIG. 14 is a front view of a second embodiment of my new design; FIG. 15 is a right side view of the second embodiment; FIG. 16 is a left side view of the second embodiment; FIG. 17 is a rear view of the second embodiment; FIG. 18 is a top view of the second embodiment; and, FIG. 19 is a left-side elevated perspective view of the second embodiment.

Any parts of the drawings indicated by broken lines are shown for illustrative purpose only and do not constitute any part of the claimed ornamental design.

1 Claim, 17 Drawing Sheets

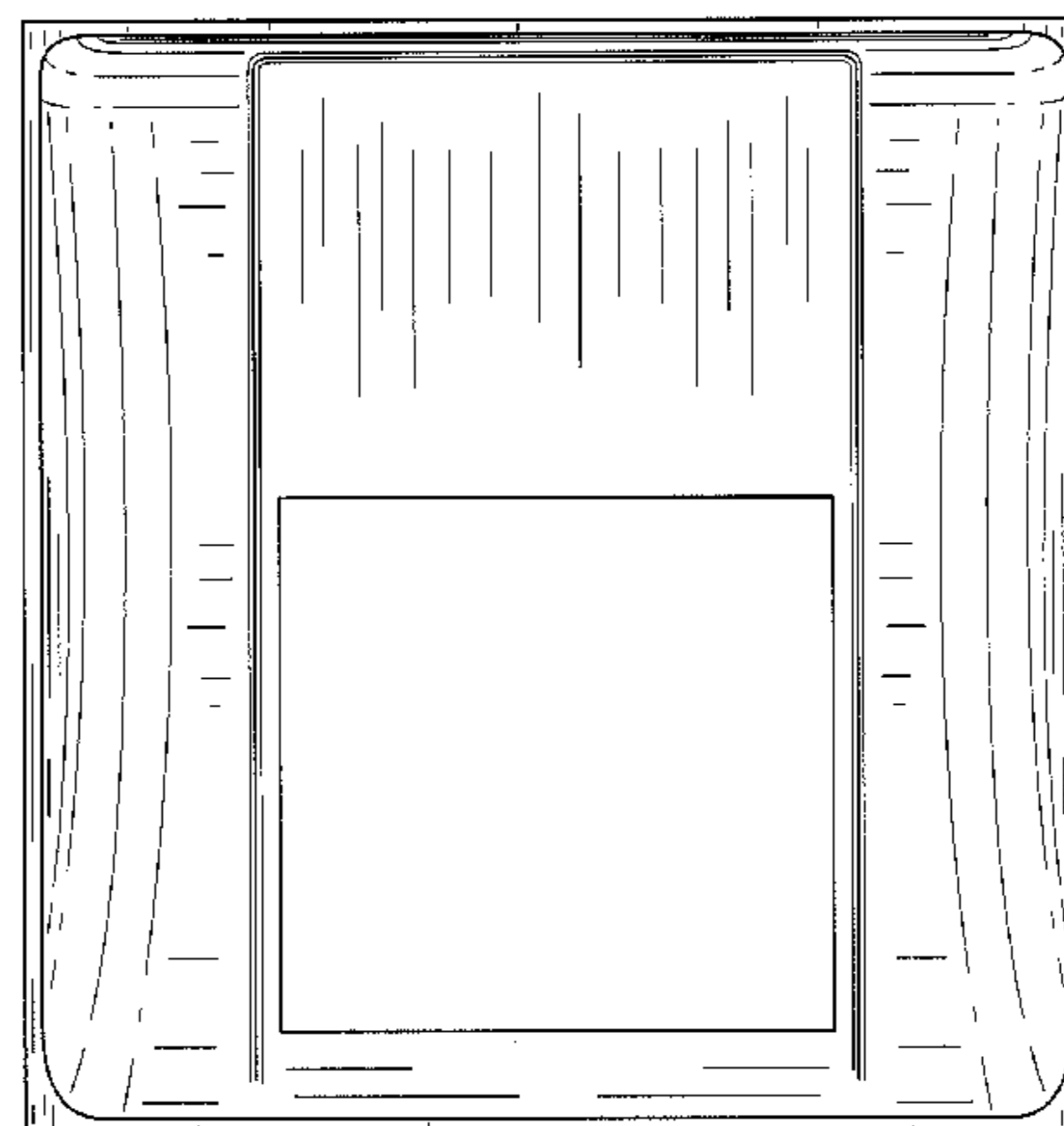
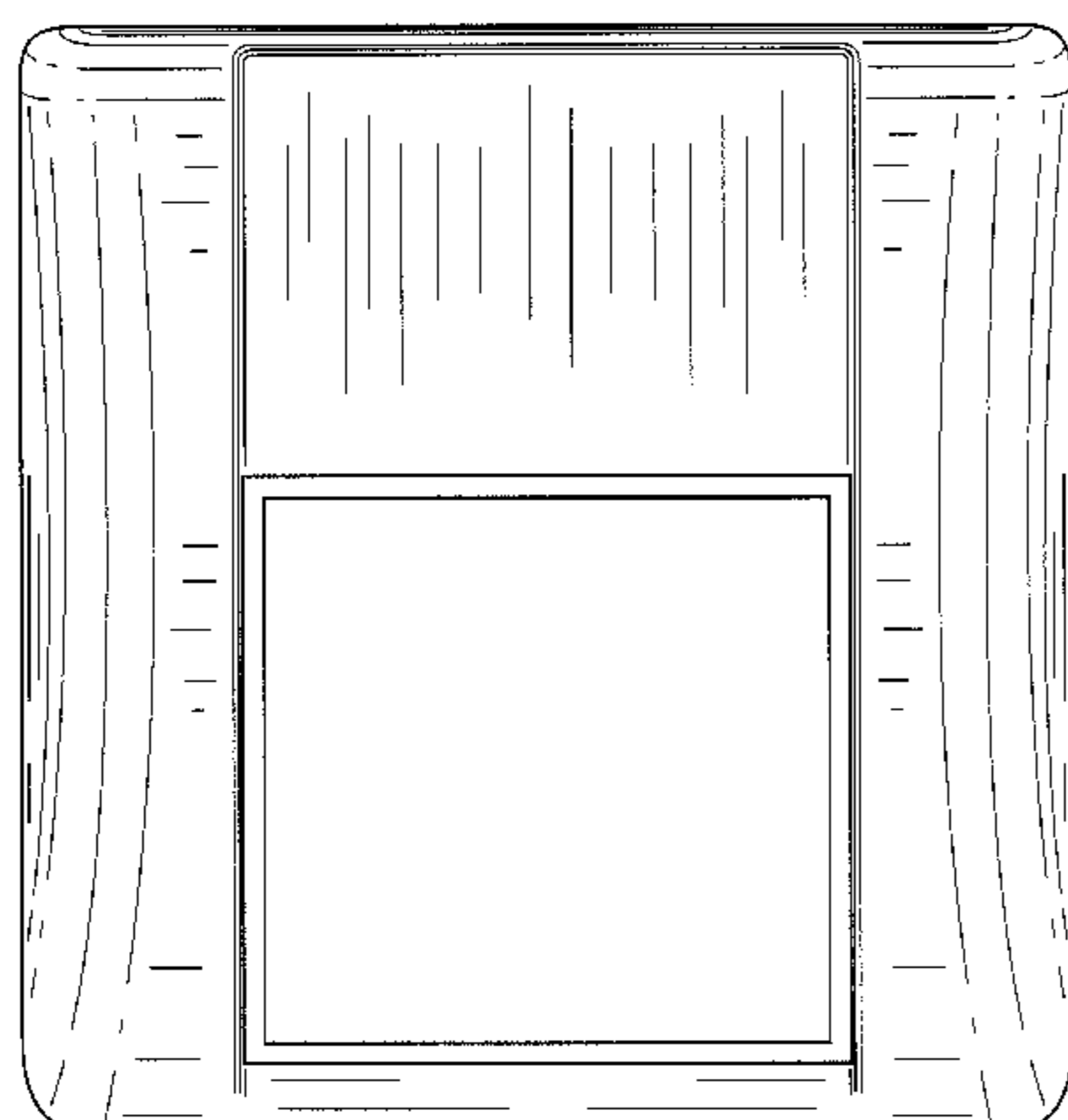

US D636,718 S

Page 2

U.S. PATENT DOCUMENTS

2008/0164726	A1 *	7/2008	MacNee et al.	296/224	2010/0019528	A1 *	1/2010	Hu et al.	296/100.02
2009/0102227	A1 *	4/2009	Herndon	296/100.06	2010/0327618	A1 *	12/2010	Soldatelli	296/100.1
2009/0229767	A1 *	9/2009	Mullet et al.	160/26					

* cited by examiner

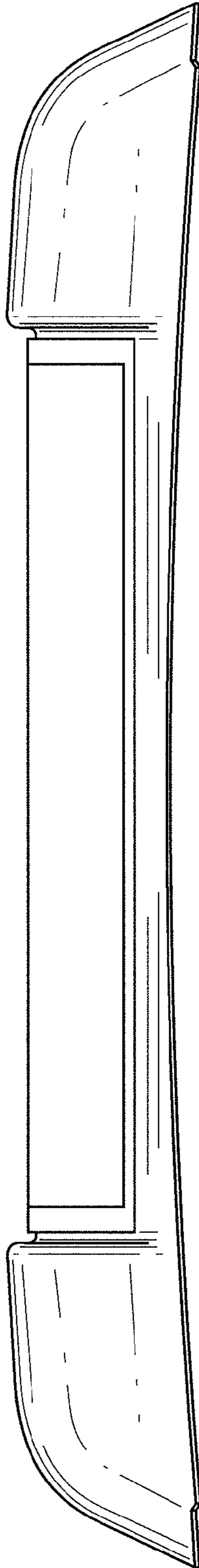

FIG. 1

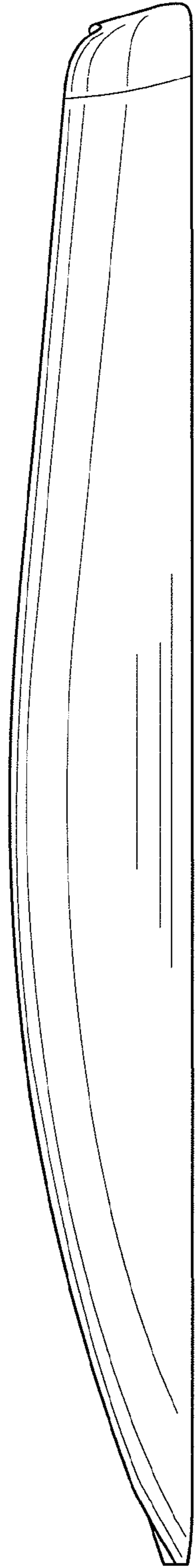

FIG. 2

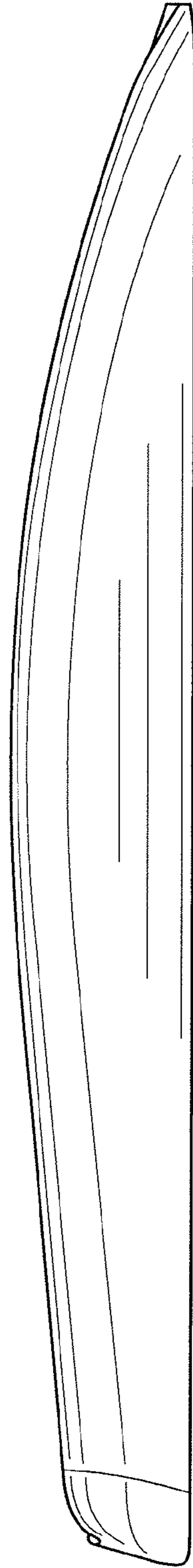

FIG. 3

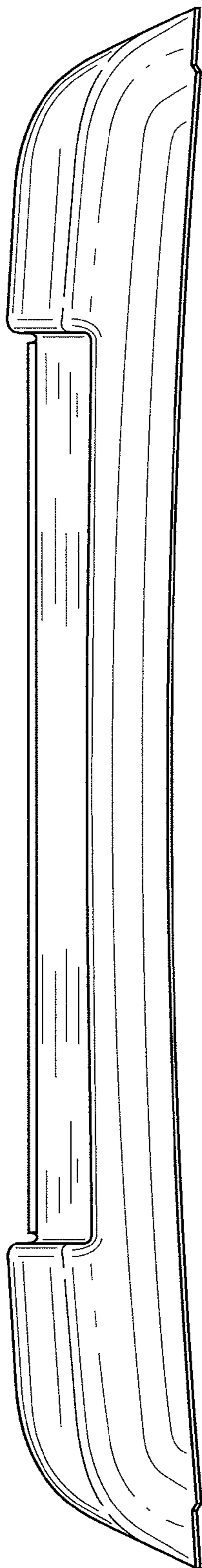
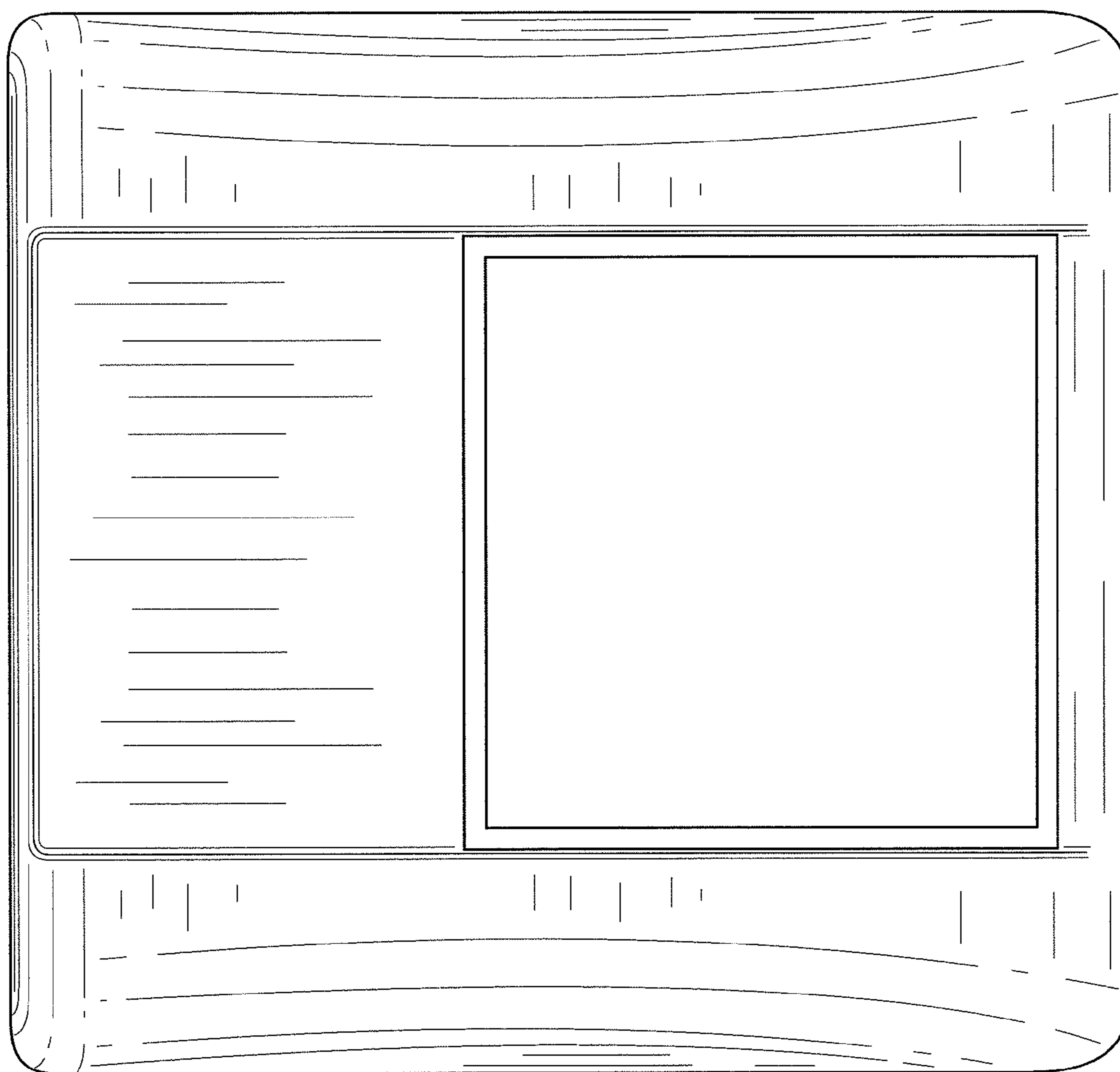

FIG. 4

FIG. 5



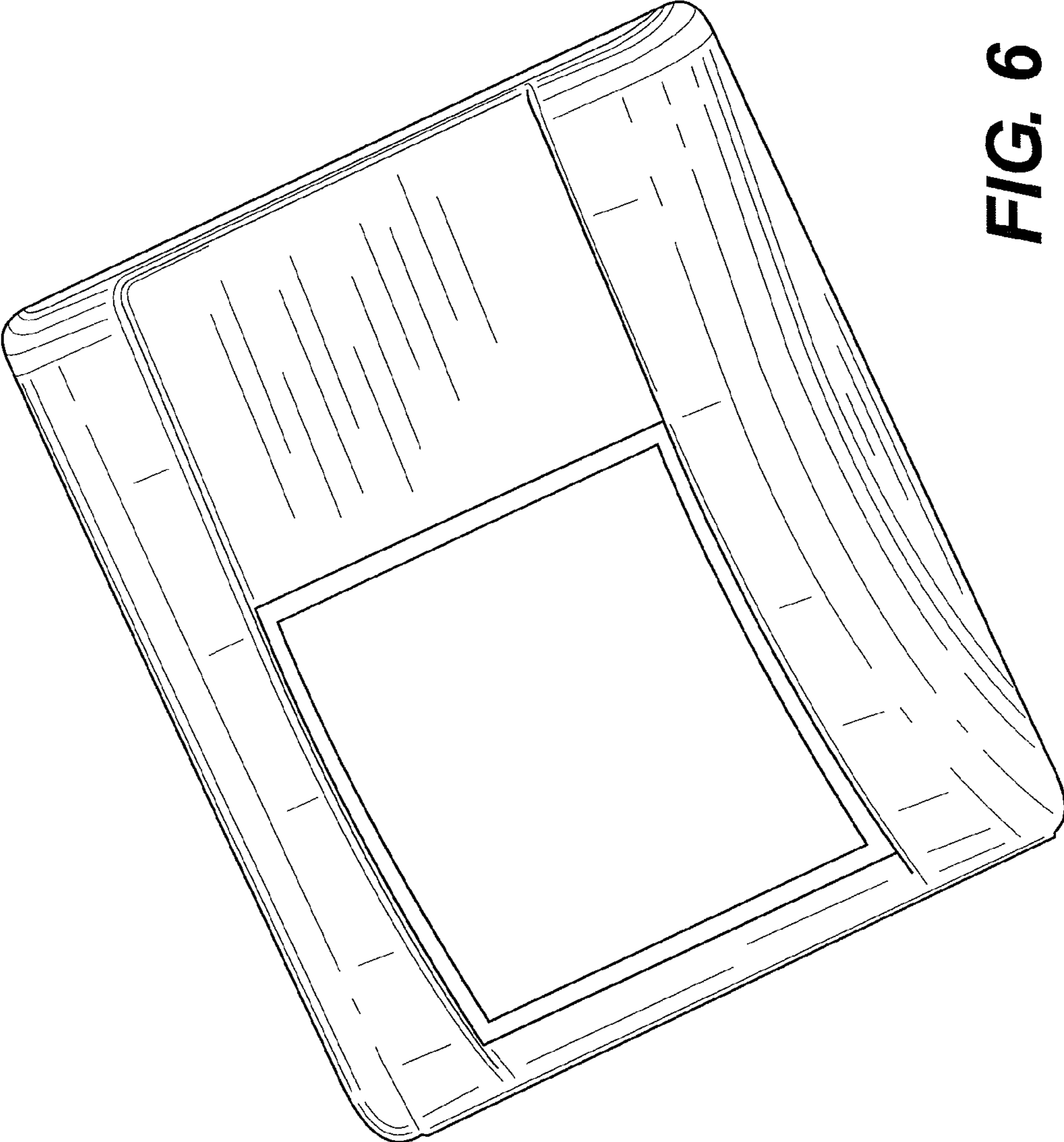

FIG. 6

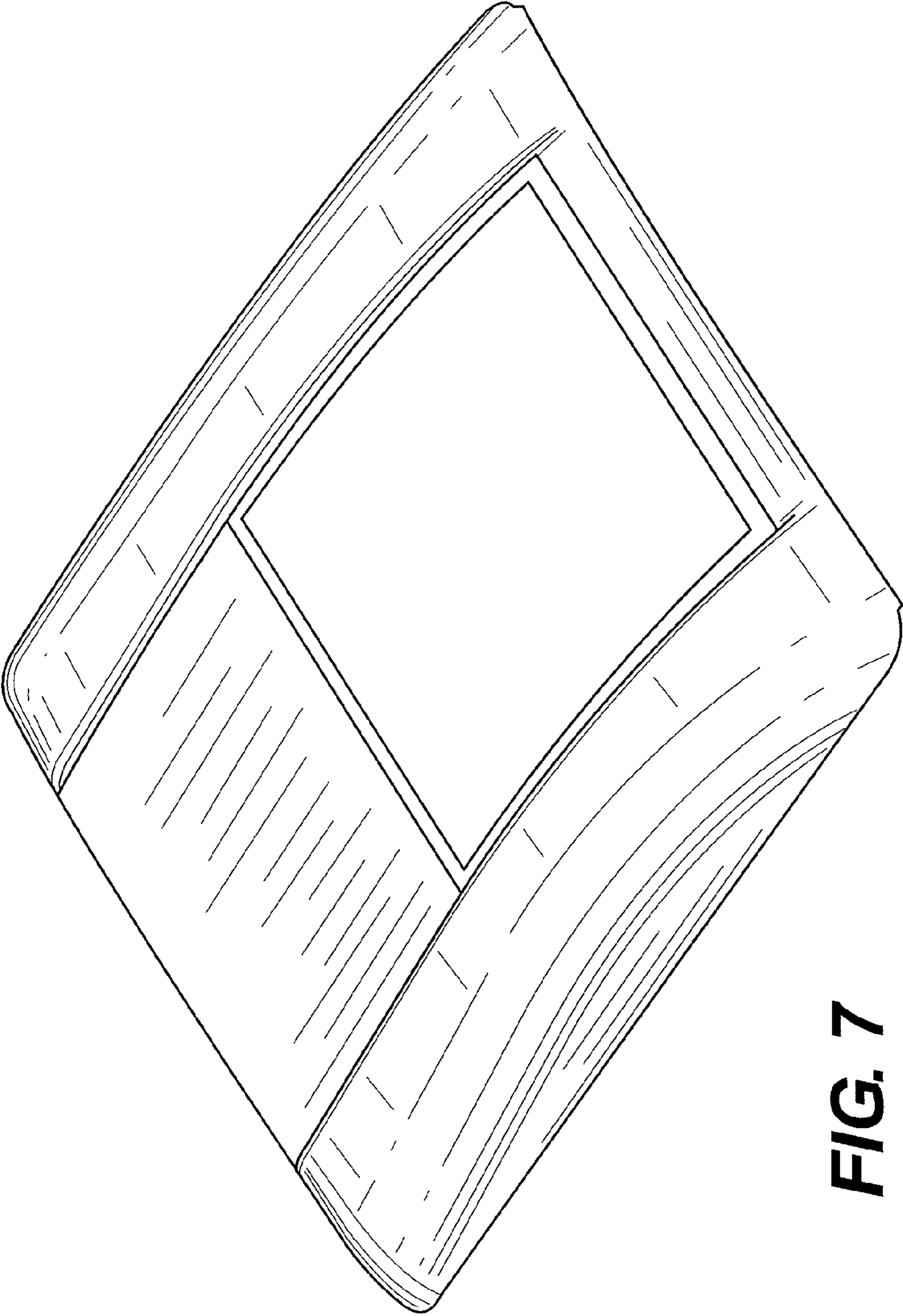

FIG. 7

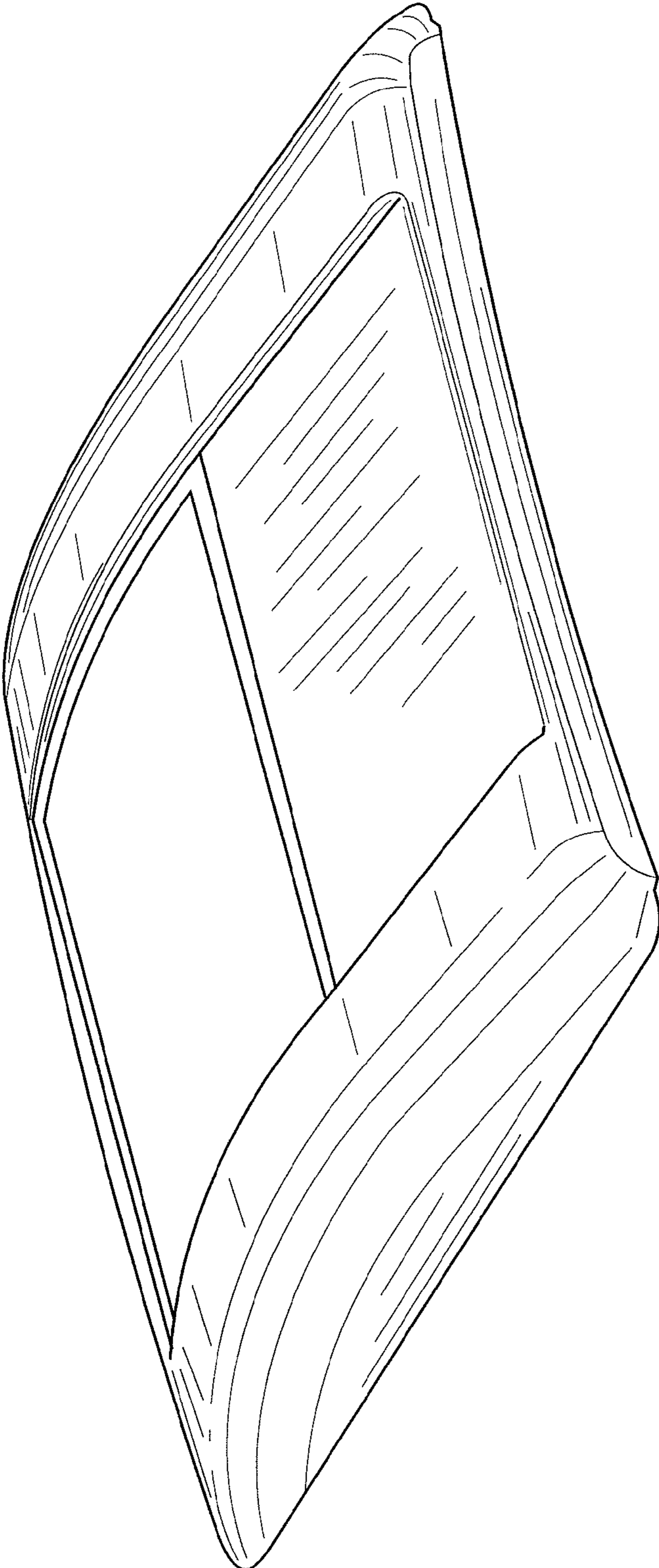

FIG. 8

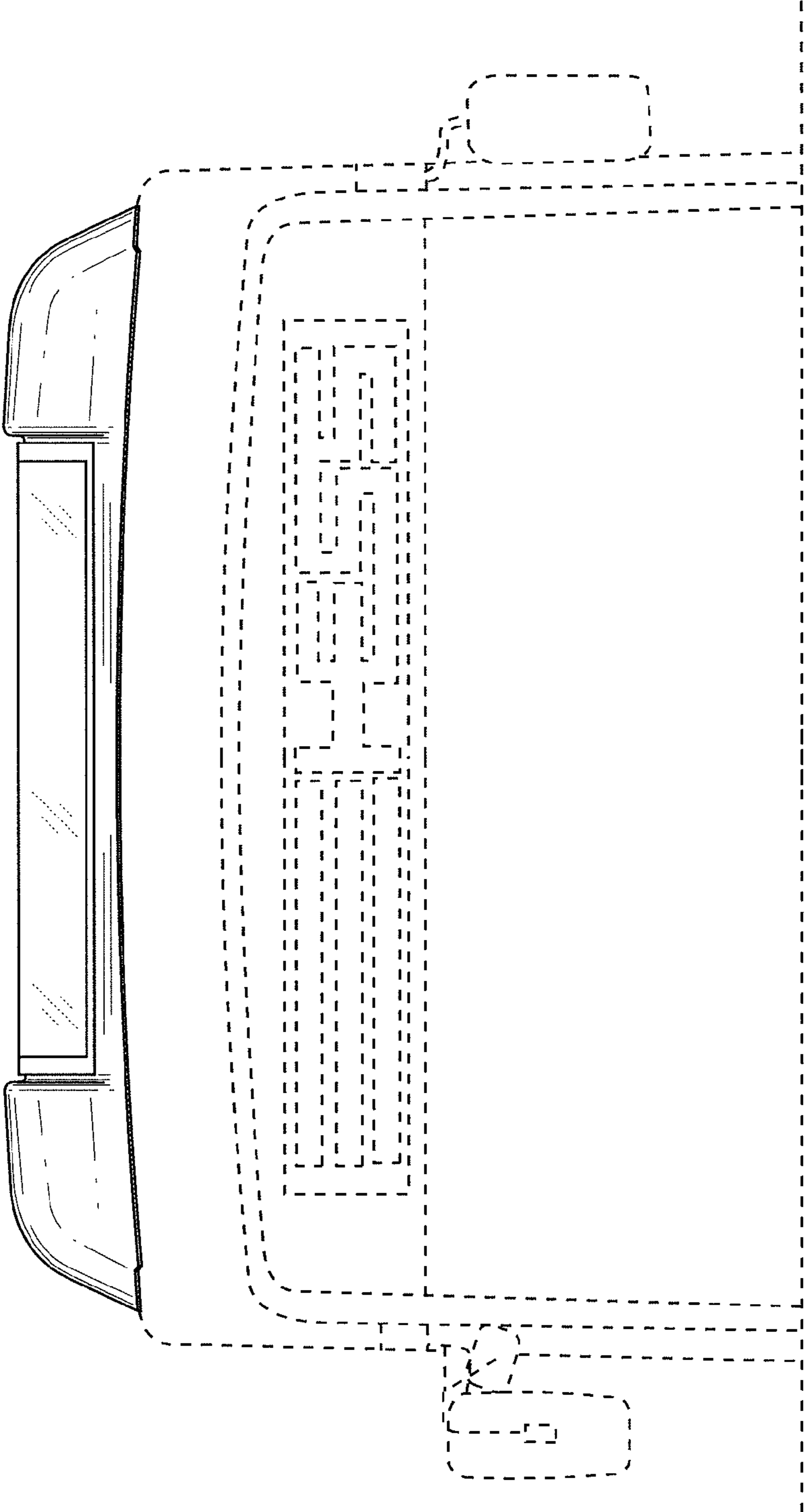

FIG. 9

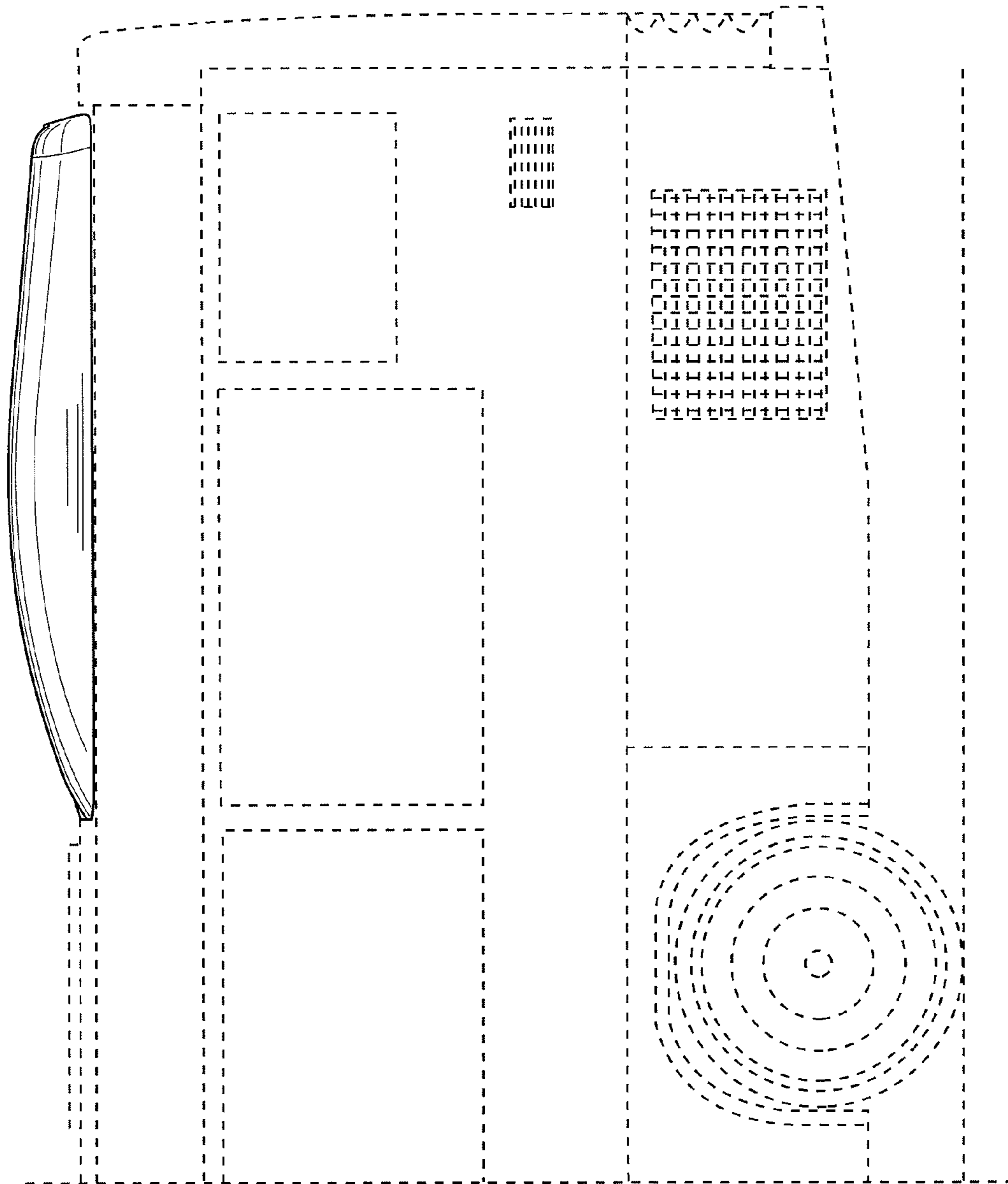
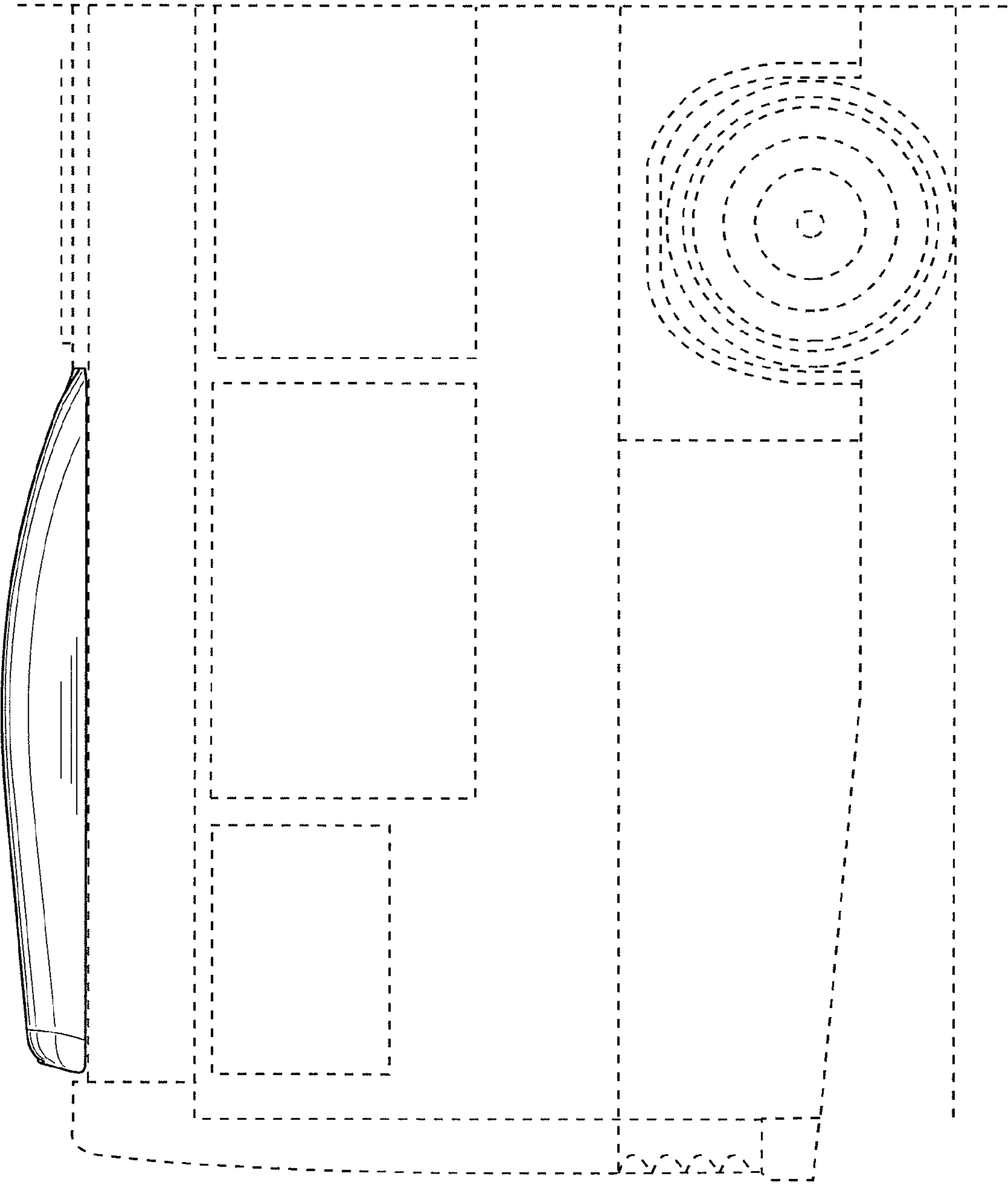

FIG. 10

FIG. 11



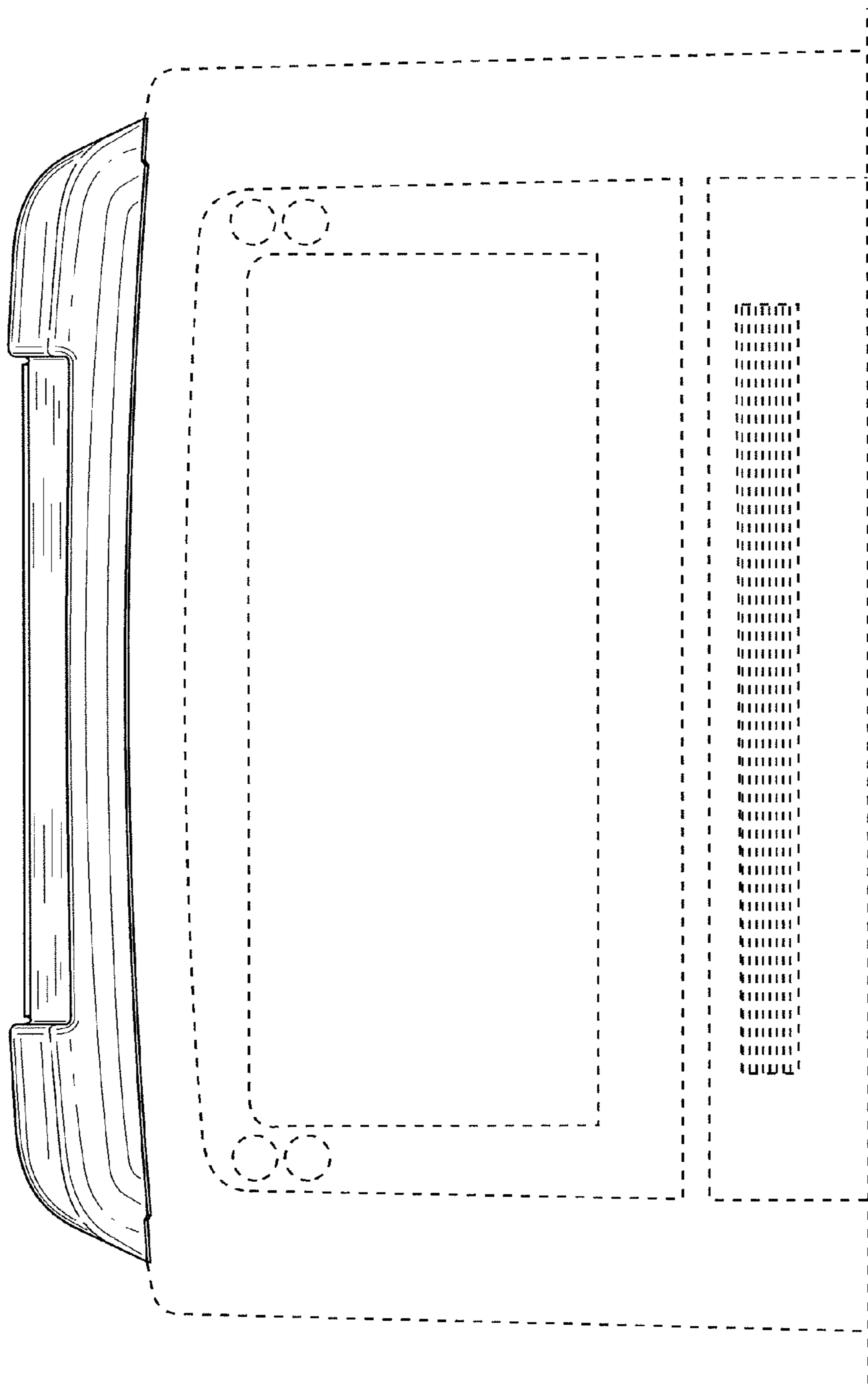
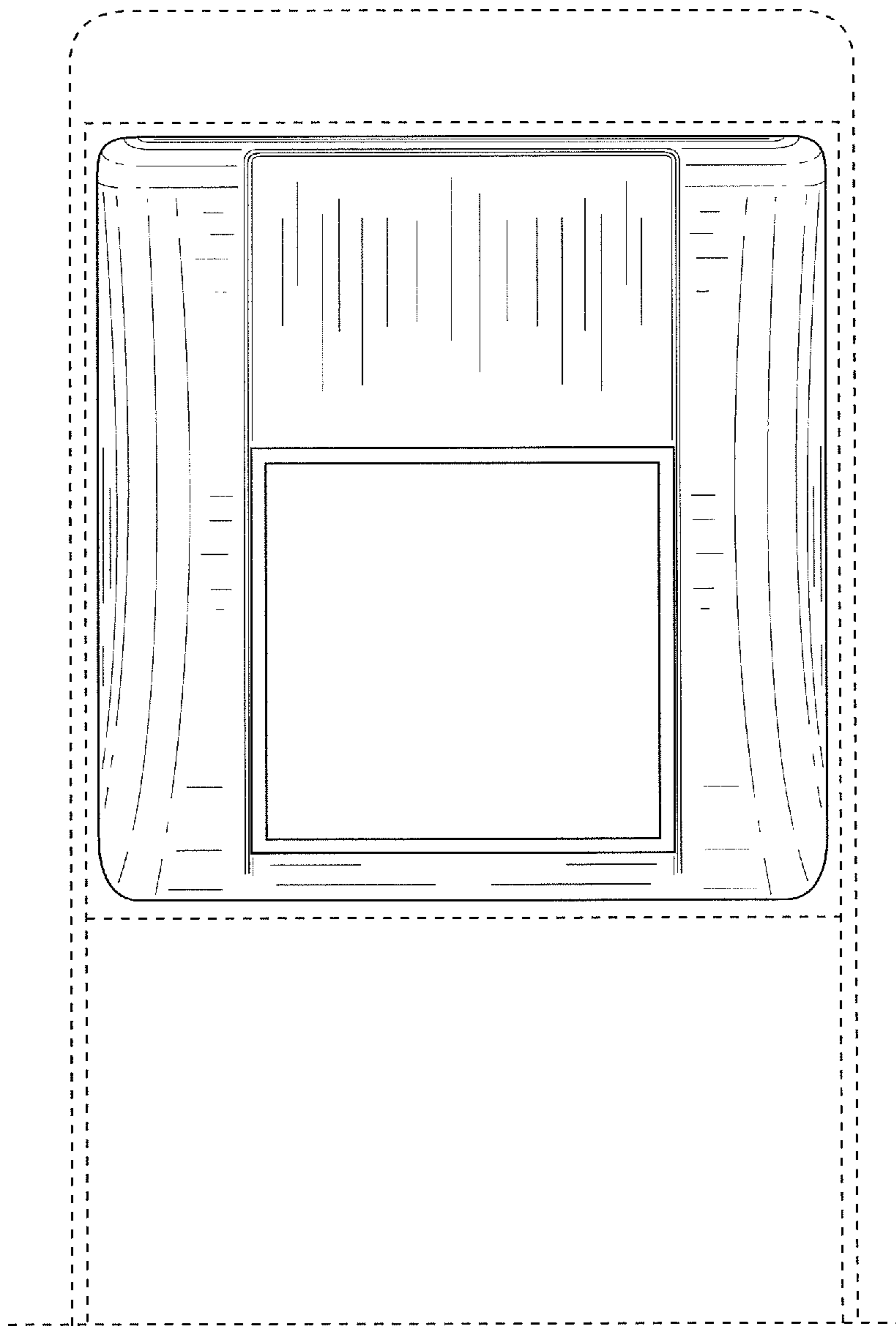

FIG. 12

FIG. 13



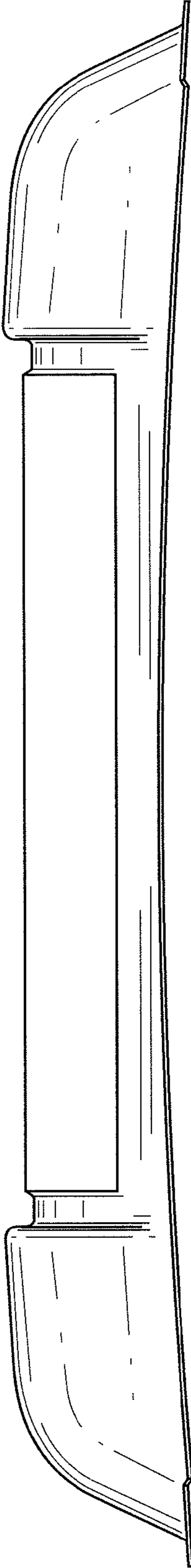

FIG. 14

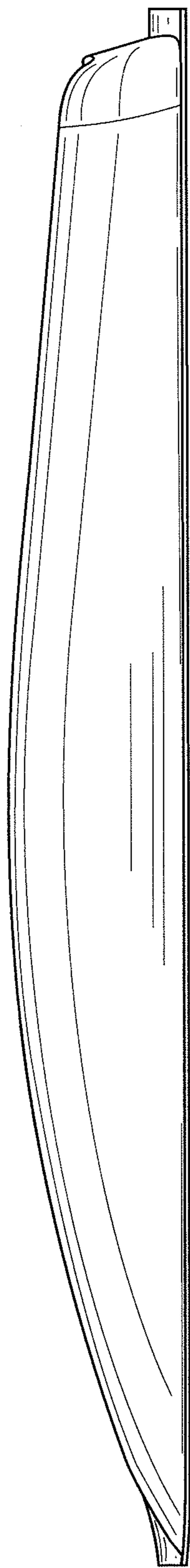

FIG. 15

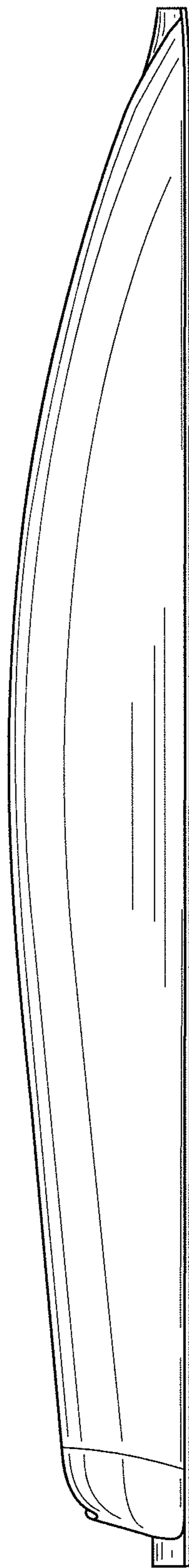

FIG. 16

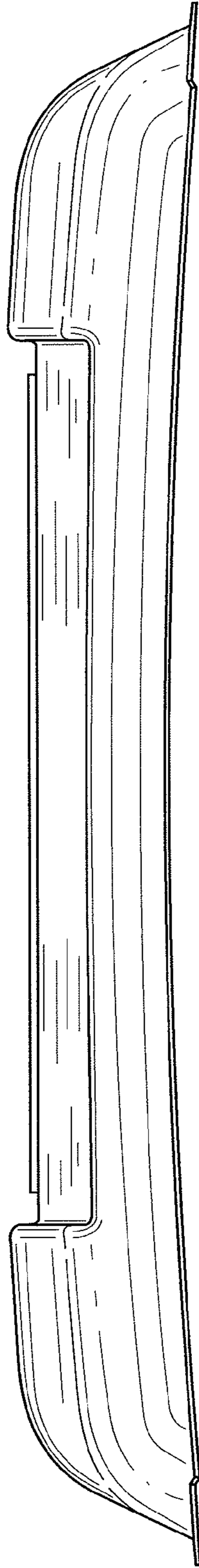

FIG. 17

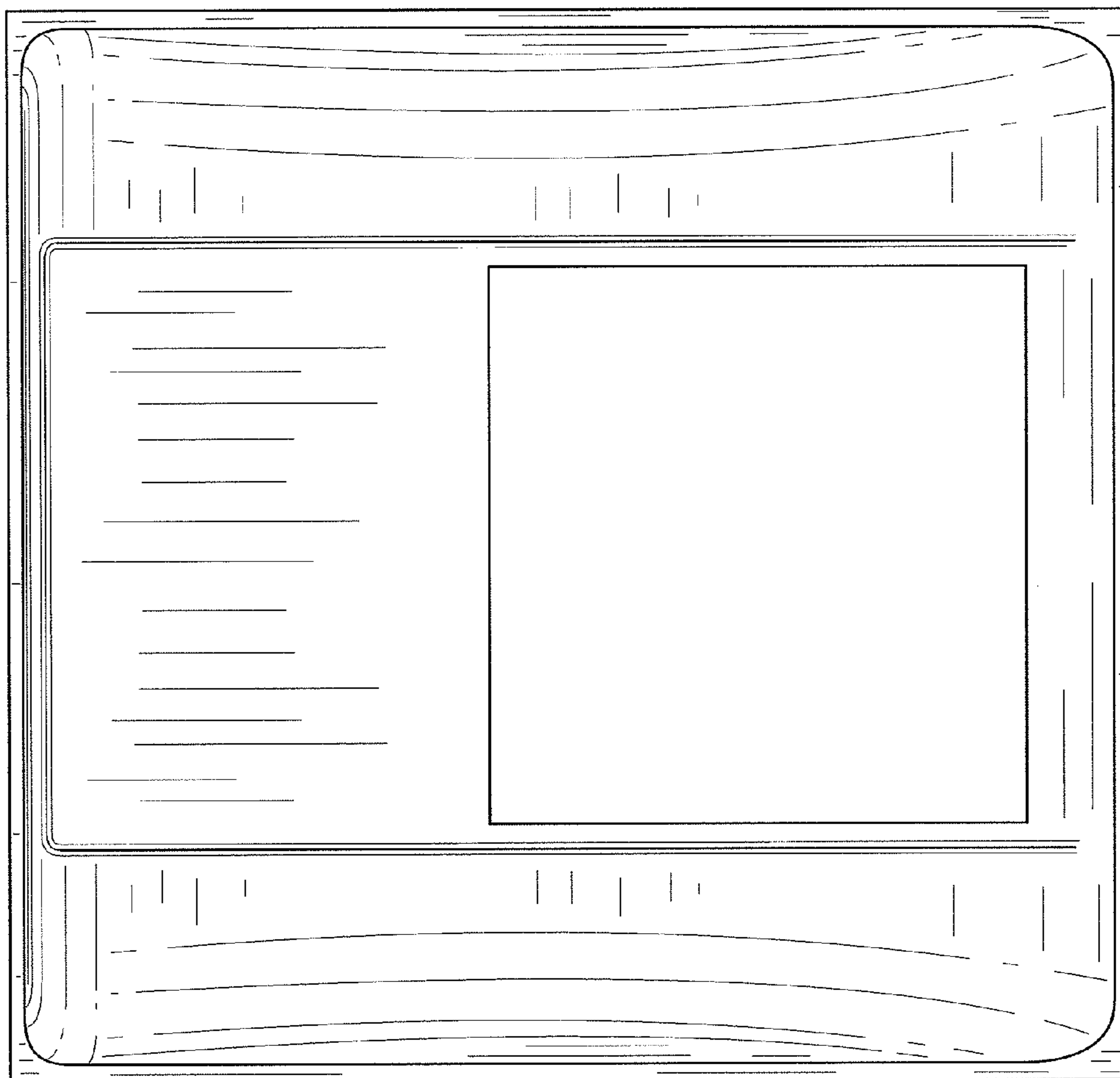

FIG. 18

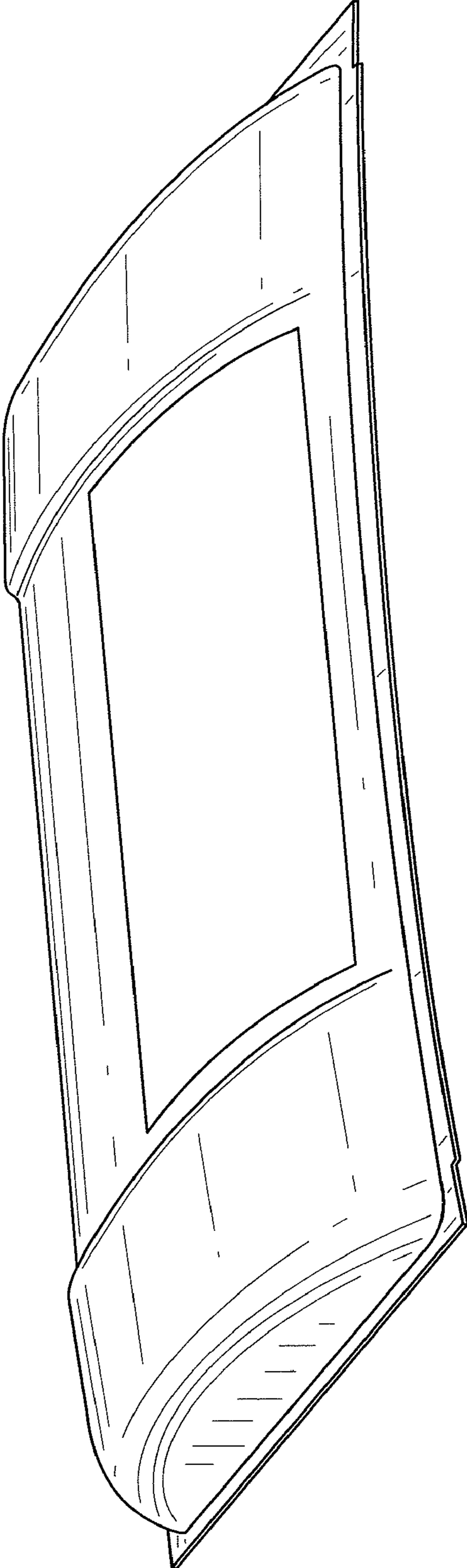

FIG. 19