



US00D636715S

(12) **United States Design Patent**  
**De Bono**

(10) **Patent No.:** **US D636,715 S**

(45) **Date of Patent:** **\*\* Apr. 26, 2011**

(54) **WHEEL OR WHEEL COVER**

(75) Inventor: **Michael Theodore De Bono**, Munich (DE)

(73) Assignee: **Bayerische Motoren Werke Aktiengesellschaft**, Munich (DE)

(\*\*) Term: **14 Years**

(21) Appl. No.: **29/347,966**

(22) Filed: **Aug. 20, 2010**

(30) **Foreign Application Priority Data**

Feb. 22, 2010 (DE) ..... 402010001117

(51) **LOC (9) Cl.** ..... **12-16**

(52) **U.S. Cl.** ..... **D12/209**

(58) **Field of Classification Search** ..... D12/204-213;  
301/37.101, 64.101, 65, 64.201

See application file for complete search history.

(56) **References Cited**

**U.S. PATENT DOCUMENTS**

- D460,937 S \* 7/2002 Nakazawa et al. .... D12/209
- D504,647 S 5/2005 Leclercq
- D507,221 S \* 7/2005 Stopka ..... D12/209
- D554,034 S \* 10/2007 Madden ..... D12/209
- D573,079 S 7/2008 Huet

- D589,425 S \* 3/2009 Theiss ..... D12/209
- D599,267 S \* 9/2009 Morgenstern et al. .... D12/211
- D614,107 S \* 4/2010 Juergens et al. .... D12/209
- D615,916 S \* 5/2010 Leone ..... D12/211
- D617,245 S \* 6/2010 Gallert ..... D12/209
- D619,069 S \* 7/2010 Patel ..... D12/209
- D620,872 S \* 8/2010 Juergens et al. .... D12/211
- D627,698 S \* 11/2010 Zhang ..... D12/209

**FOREIGN PATENT DOCUMENTS**

- EM 000065966-0004 9/2004
- EM 000754593-0003 9/2007

\* cited by examiner

*Primary Examiner* — Stacia Cadmus

(74) *Attorney, Agent, or Firm* — Crowell & Moring LLP

(57) **CLAIM**

The ornamental design for a wheel or wheel cover, as shown and described.

**DESCRIPTION**

FIG. 1 is a front view of a wheel or wheel cover according to my design; and,

FIG. 2 is a perspective view thereof.

The broken line showing of the rear of the rim and the bolt holes and the center cap in the central hub area is included for the purpose of illustrating environment and forms no part of the claimed design.

**1 Claim, 1 Drawing Sheet**

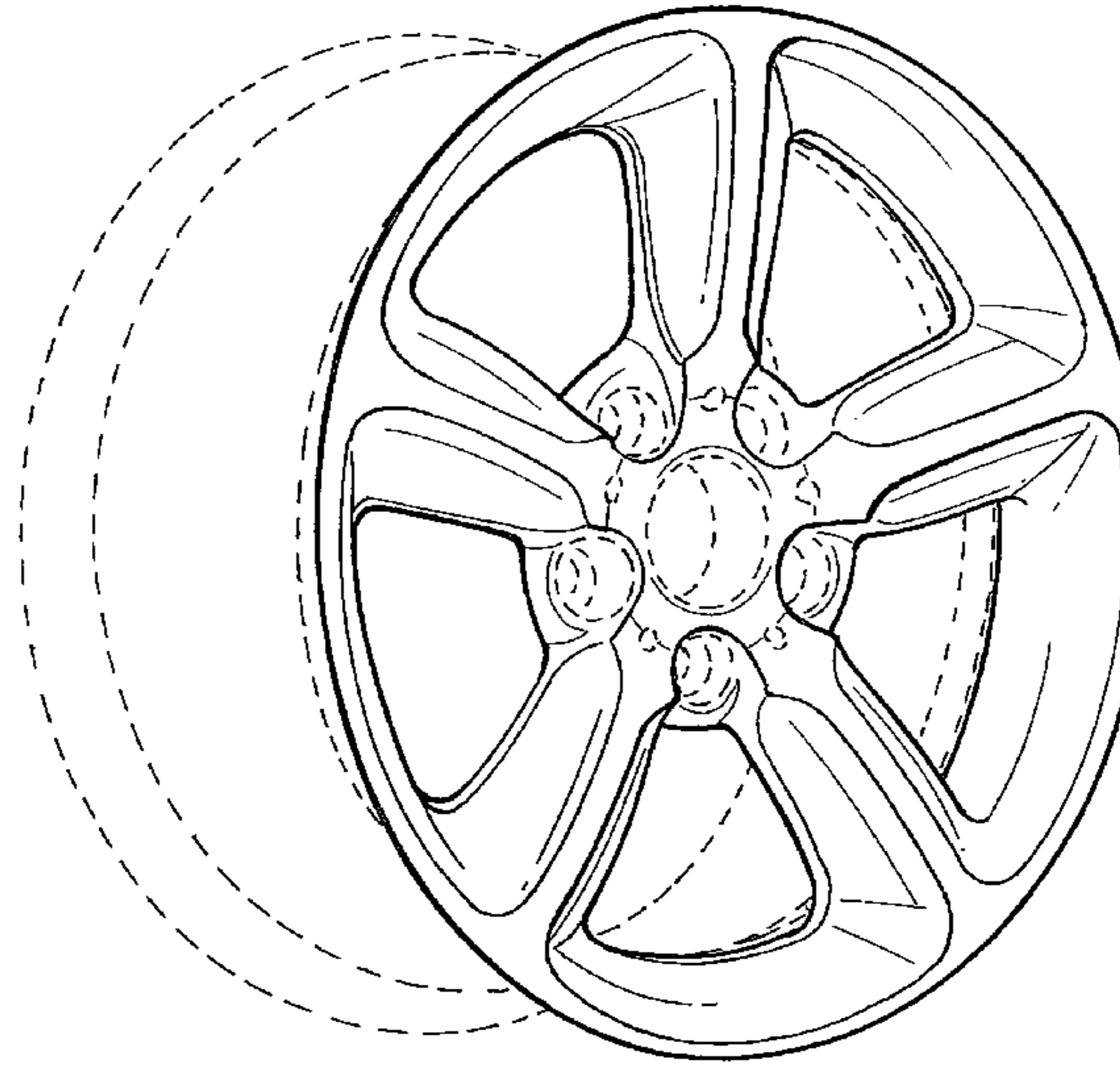
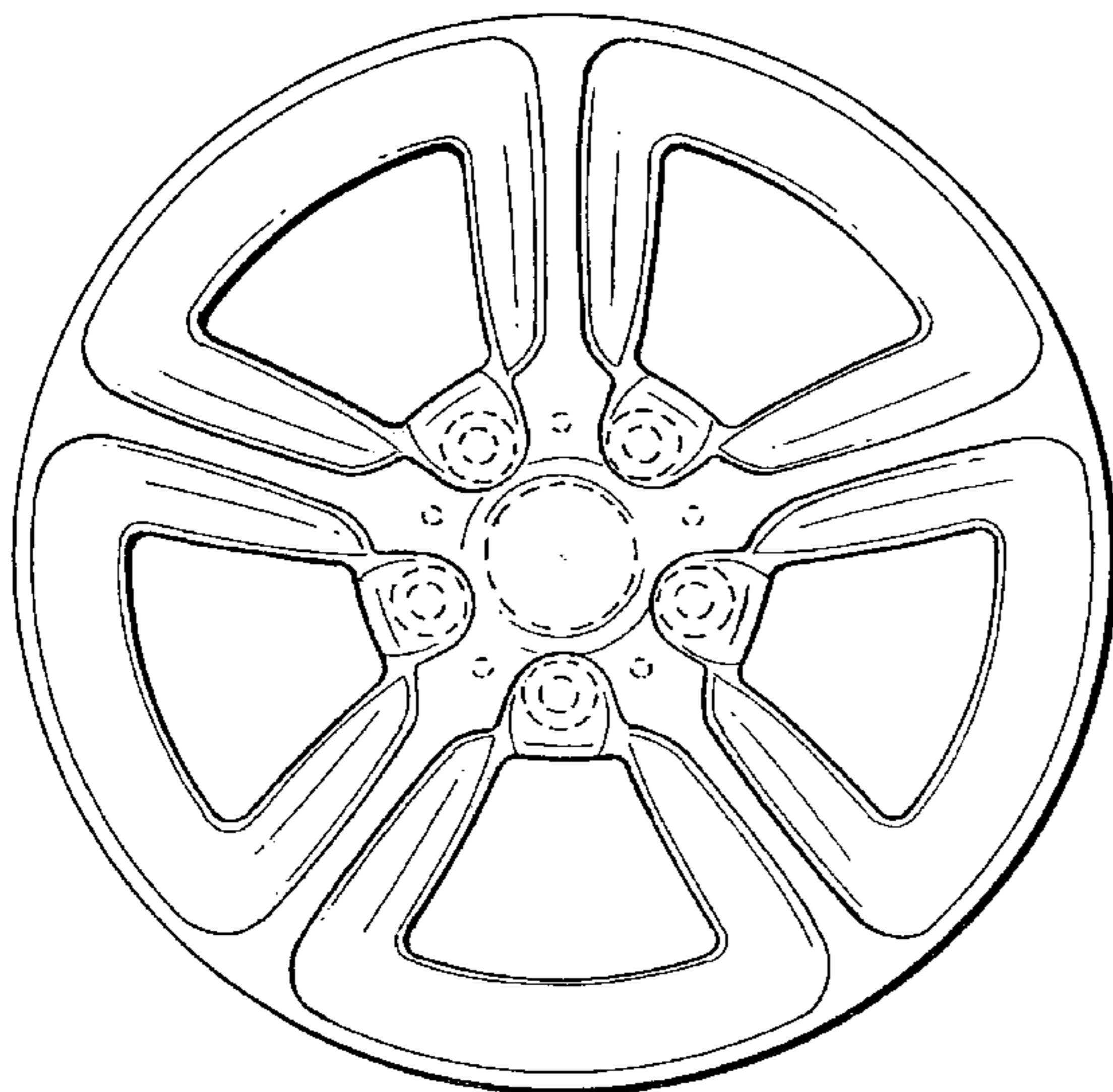

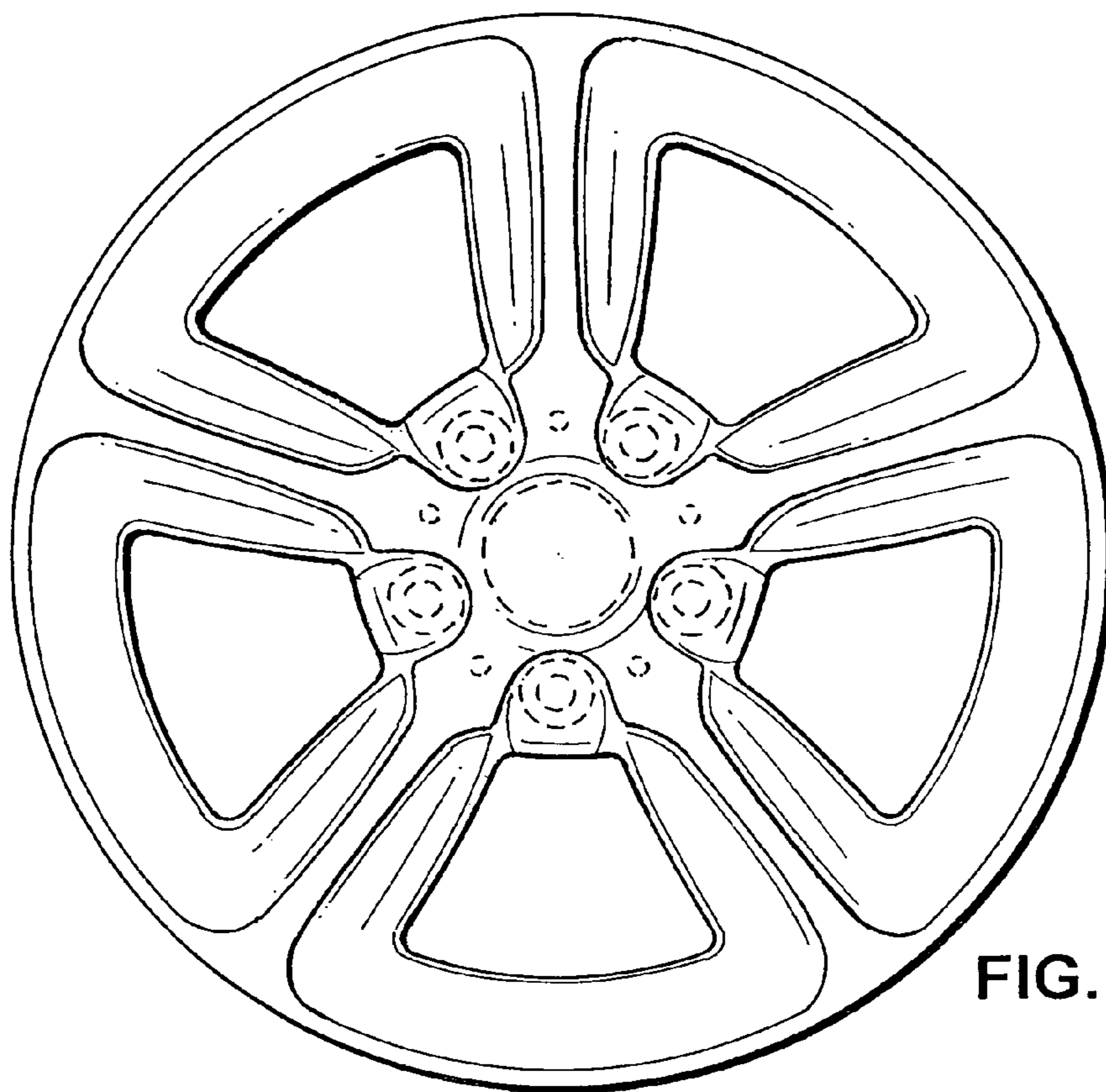

FIG. 1

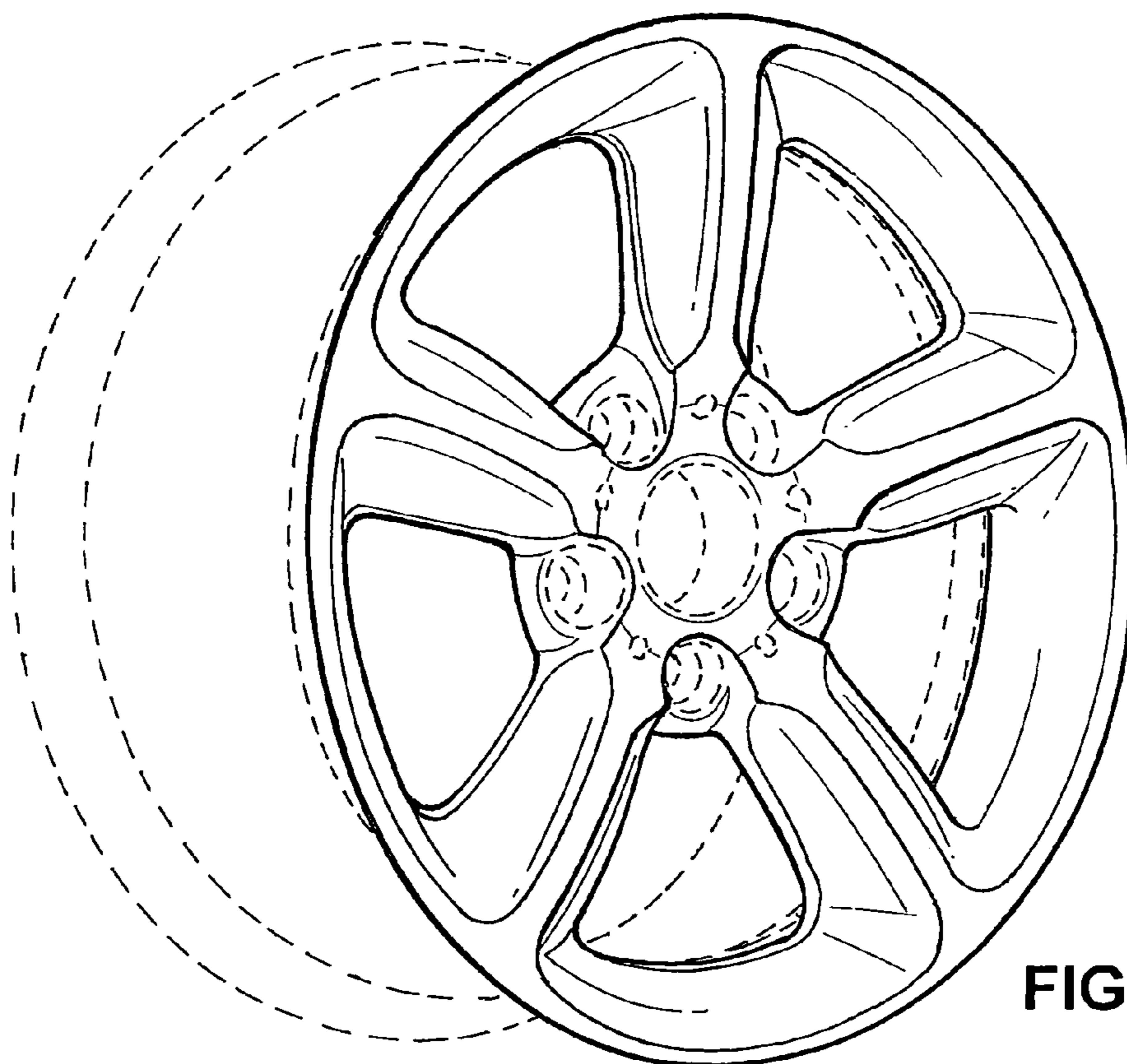

FIG. 2