



US00D636707S

(12) **United States Design Patent**
Bracy et al.

(10) **Patent No.:** **US D636,707 S**
(45) **Date of Patent:** **** Apr. 26, 2011**

(54) **VEHICLE**

(75) Inventors: **Garth Bracy**, Long Lake, MN (US);
Matthew D. Tandrup, Chanhassen, MN (US)

(73) Assignee: **Polaris Industries Inc.**, Medina, MN (US)

(**) Term: **14 Years**

(21) Appl. No.: **29/338,582**

(22) Filed: **Jun. 15, 2009**

(51) **LOC (9) Cl.** **12-11**

(52) **U.S. Cl.** **D12/107**

(58) **Field of Classification Search** D12/3,
D12/86, 87, 107, 110; 180/225, 223, 233,
180/229, 311, 312, 315

See application file for complete search history.

(56) **References Cited**

U.S. PATENT DOCUMENTS

D440,188 S *	4/2001	Lin	D12/107
D452,189 S *	12/2001	Doran	D12/86
D501,570 S	2/2005	Tandrup et al.		
D518,423 S	4/2006	Tandrup et al.		
D519,439 S	4/2006	Dahl et al.		
D520,252 S	5/2006	Tandrup et al.		
D555,036 S	11/2007	Eck		
D562,734 S	2/2008	Tandrup		
D592,556 S *	5/2009	Mehra	D12/107
D592,557 S *	5/2009	Mehra	D12/107
D595,188 S *	6/2009	Tandrup	D12/107
D610,514 S	2/2010	Eck		

OTHER PUBLICATIONS

Can-Am® BRP 2008 Operator's Guide, DS250™, © 2007, Front cover, pp. 54, 58, 59, 64, and rear cover, Bombardier Recreational Products, Inc.

Can-Am® BRP 2008 Operator's Guide, Outlander™, © 2007, Front cover, pp. 55, 60, 65, 66, and rear cover, Bombardier Recreational Products, Inc.

Can-Am® BRP 2008 Operator's Guide, Renegade™ 500/80/800 X, © 2007, Front cover, pp. 60, 65-67, and rear cover, Bombardier Recreational Products, Inc.

Vehicle Reviews for 2004 Can-Am Outlander™ 330 HO 4x4, retrieved from www.powersportsnetwork.com on Mar. 4, 2010, 1 pg.

2008 Renegade® 500 H.O. EFI Features and Specs, retrieved from www.atv.off-road.com on Mar. 4, 2010, 5 pgs., dated Jun. 2, 2007.

2004 Honda Sportrax® 250EX TRX250EX ATV's, retrieved from www.powersportsnetwork.com on Mar. 4, 2010, 2 pgs.

Honda 2009 Fourtrax® Rancher® AT brochure, © 2008, 2 pgs.

Honda 2009 TRX300X brochure, © 2009, 2 pgs.

2003 Kawasaki Mohave ATV, retrieved from www.atv.off-road.com on Mar. 4, 2010, 4 pgs., dated Oct. 1, 2005.

2008 Kawasaki Prairie® 360 4x4, retrieved from www.powersportsnetwork.com on Mar. 4, 2010, 5 pgs.

Suzuki Eiger 400 4x4, retrieved from www.Suzuki-bikes.com on Mar. 4, 2010, 2 pgs., dated Jul. 6, 2006.

(Continued)

Primary Examiner — Philip S Hyder

Assistant Examiner — Linda G. Brooks

(74) *Attorney, Agent, or Firm* — Baker & Daniels LLP

(57) **CLAIM**

We claim the ornamental design for the vehicle, as shown and described.

DESCRIPTION

FIG. 1 shows a front left perspective view of the vehicle of the present design;

FIG. 2 shows a left side view of the vehicle shown in FIG. 1;

FIG. 3 shows a right side view of the vehicle shown in FIG. 1;

FIG. 4 shows a top view of the vehicle shown in FIG. 1;

FIG. 5 shows a front view of the vehicle shown in FIG. 1; and, FIG. 6 shows a rear view of the vehicle shown in FIG. 1.

The broken lines show portions of the vehicle that form no part of the claimed design.

1 Claim, 5 Drawing Sheets

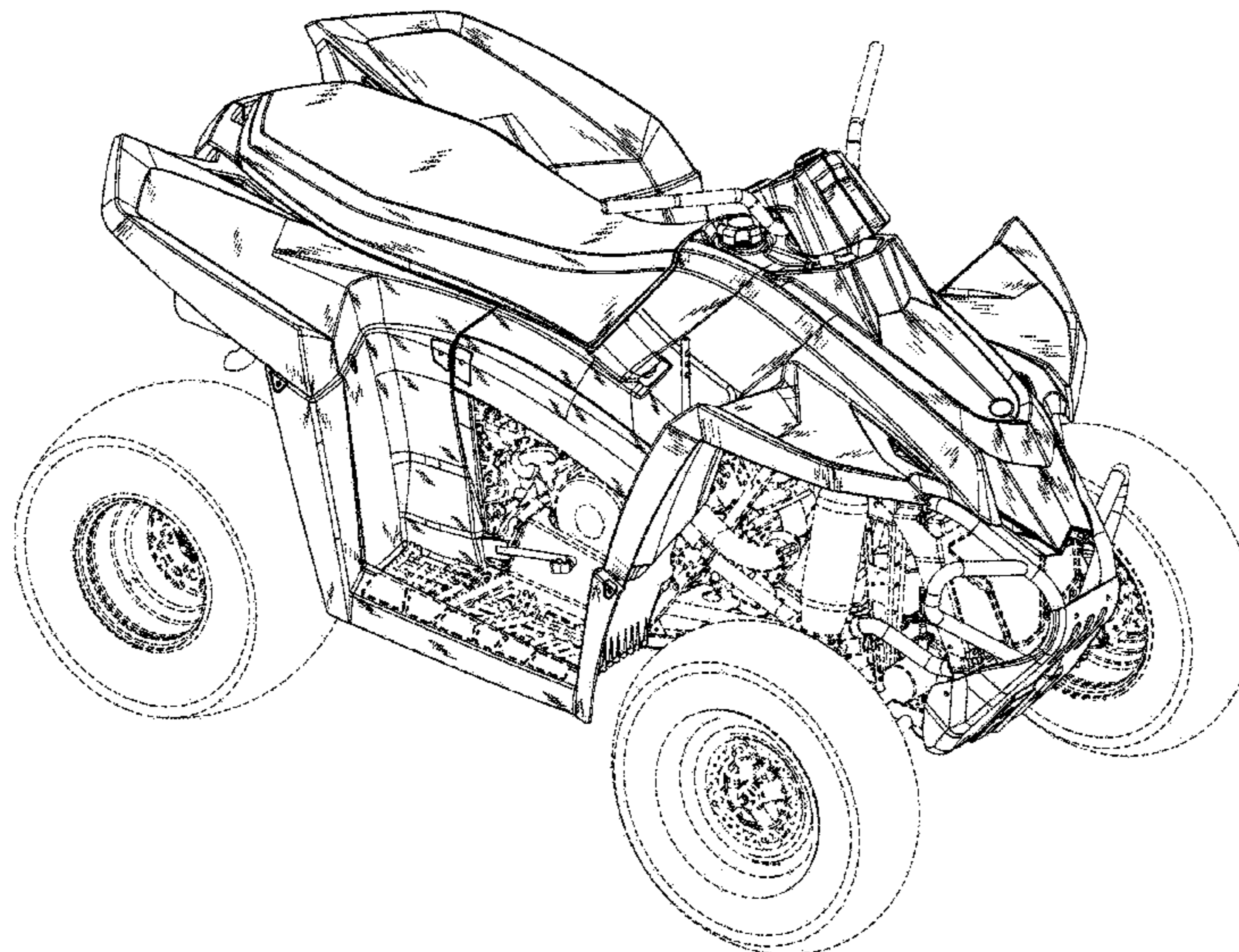

OTHER PUBLICATIONS

Suzuki Cycles—Product Lines—ATVs—Products—QuadSport Z250—2008—LTZ 250, retrieved from www.suzukicycles.com on Mar. 4, 2010, 1 pg.

The All- New Polaris 2004 All Terrain Vehicles Catalog, 52 pgs.

The All- New Polaris ATP Catalog, 14 pgs., © 2003.

Polaris 2005 ATV Catalog, 25 pgs.

Polaris 2007 ATV Catalog, 36 pgs.

Polaris 2008 ATV Catalog, 40 pgs.

Polaris 2009 ATV Catalog, 46 pgs.

1997 Yamaha Warrior Motorcycle, retrieved from www.motorcycle.com on Mar. 4, 2010, 6 pgs., dated Apr. 20, 1997.

2006 Yamaha Blaster, retrieved from www.yamaha-motor.com on Mar. 4, 2010, 1 pg.

Yamaha Wolverine 4x4 350, retrieved from www.yamaha-motor.com on Mar. 4, 2010, 6 pgs.

2010 Yamaha Grizzly 350 Automatic, retrieved from www.yamaha-motor.com on Mar. 4, 2010, 1 pg.

2010 Yamaha Raptor 250, retrieved from www.yamaha-motor.com on Mar. 4, 2010, 1 pg.

2010 Yamaha Raptor 350, retrieved from www.yamaha-motor.com on Mar. 4, 2010, 2 pgs.

* cited by examiner

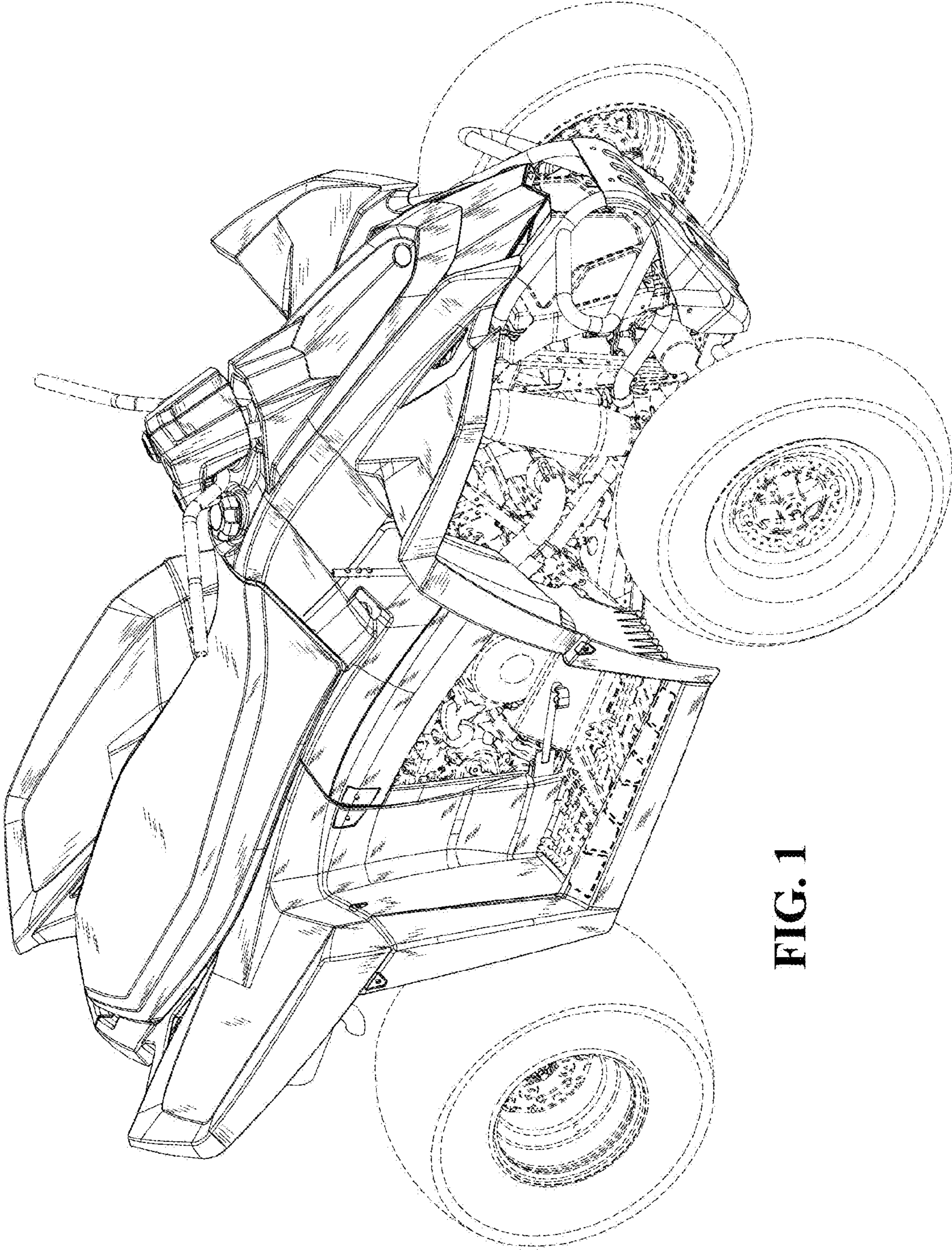

FIG. 1

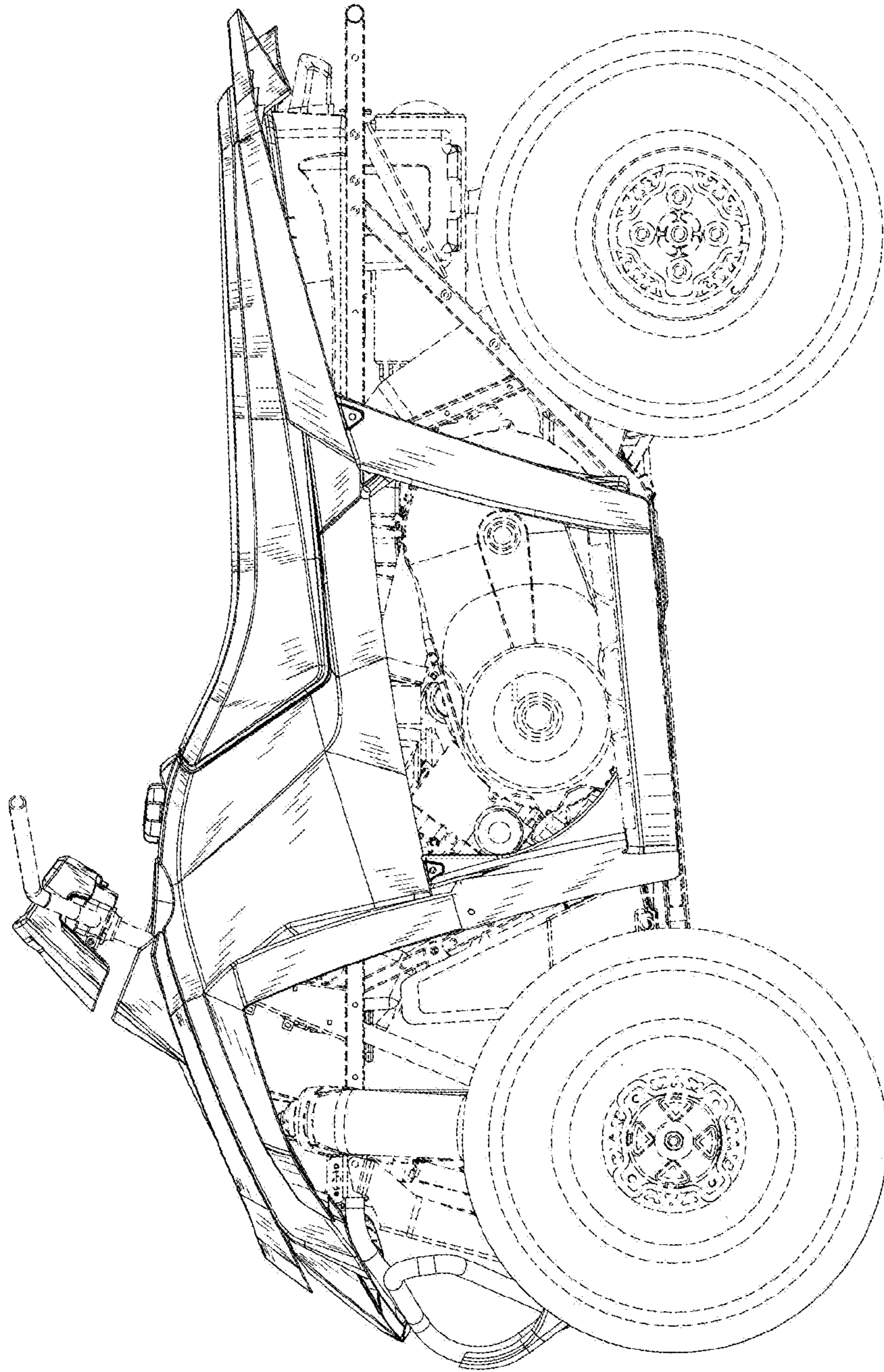

FIG. 2

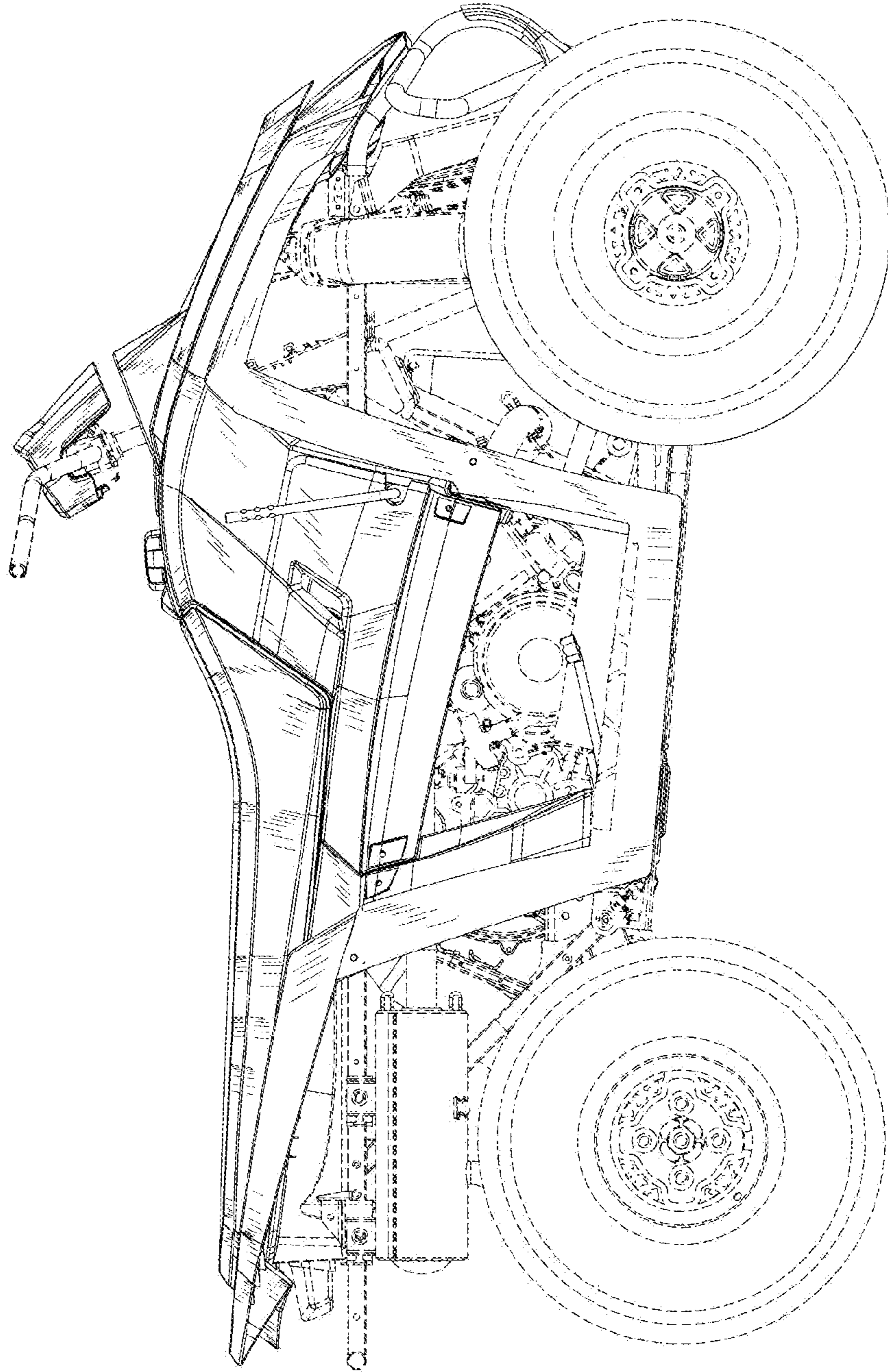

FIG. 3

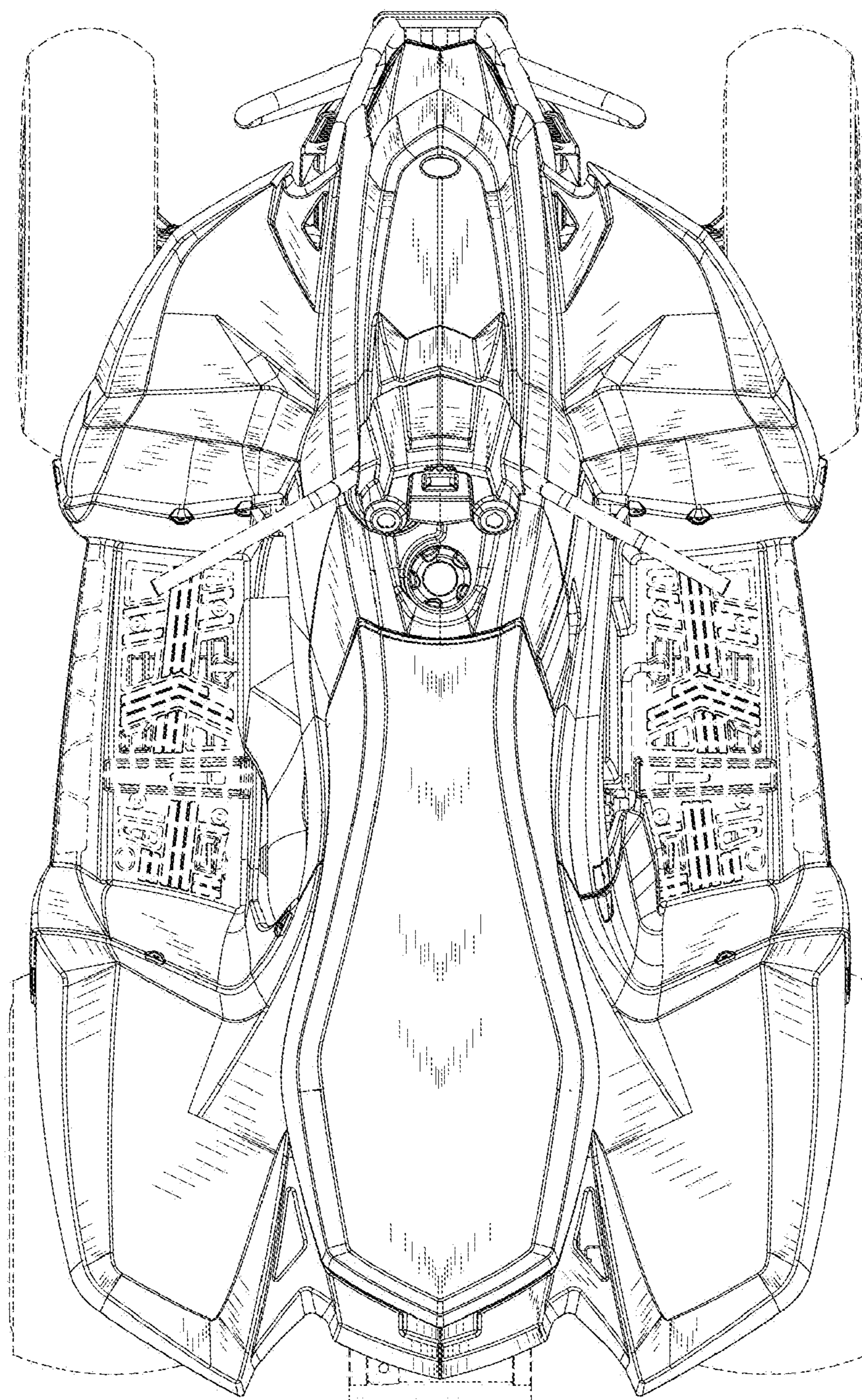

FIG. 4

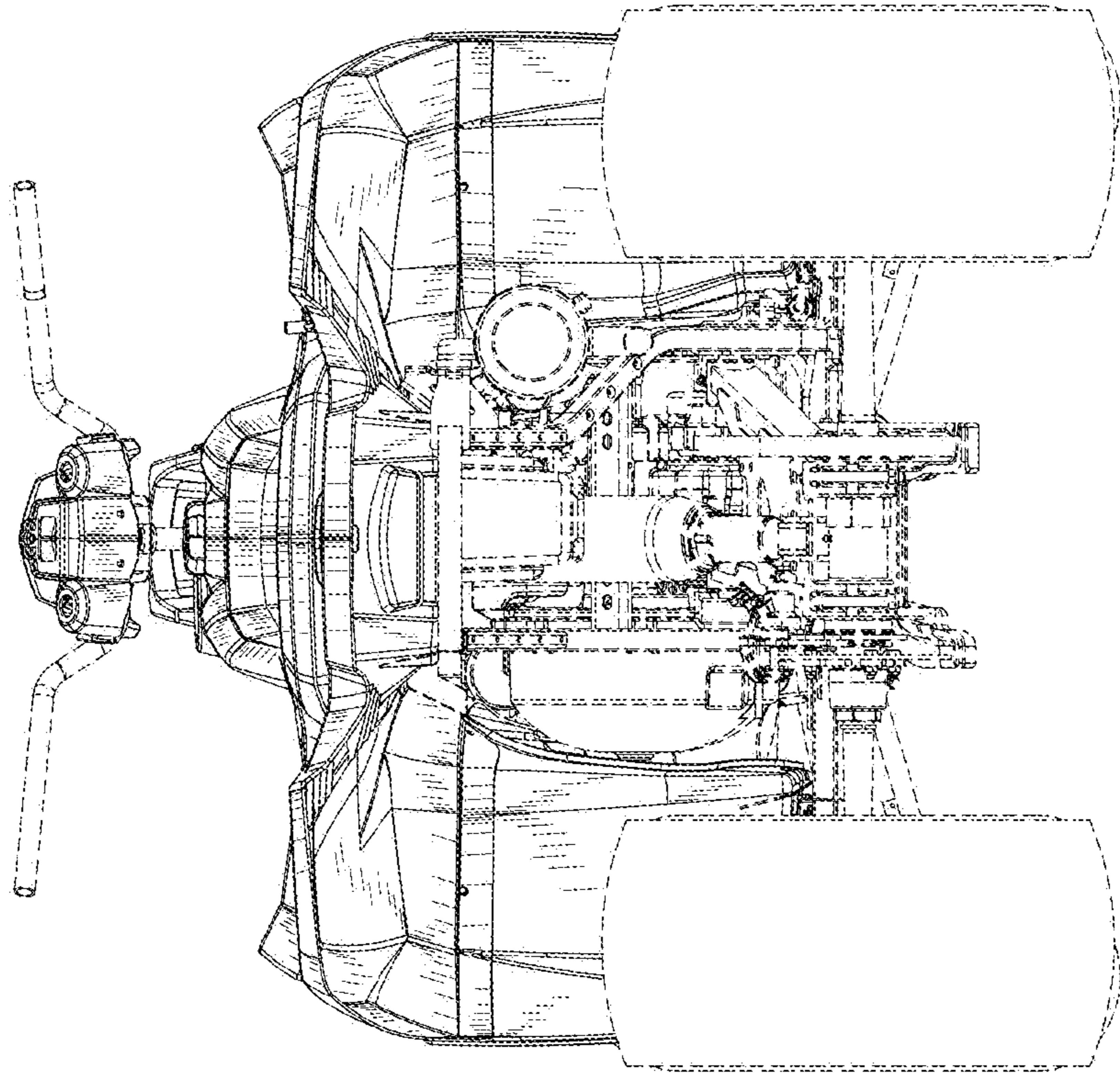

FIG. 6

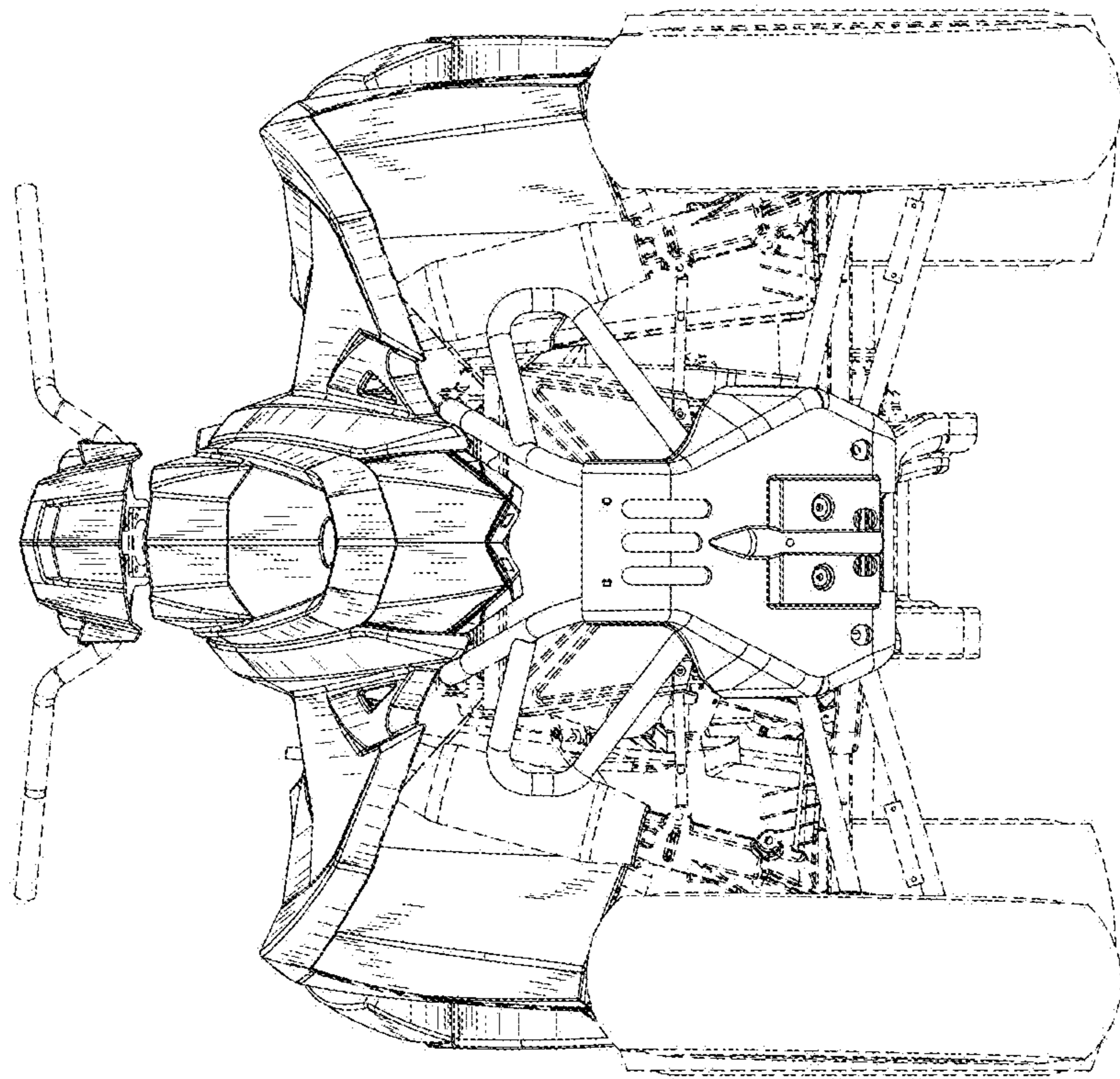

FIG. 5