



US00D636432S

(12) **United States Design Patent**
Huotari et al.

(10) **Patent No.:** **US D636,432 S**

(45) **Date of Patent:** **** *Apr. 19, 2011**

(54) **BOOK BINDING MACHINE**

(56) **References Cited**

(75) Inventors: **Iisakki Huotari**, Helsinki (FI); **Teemu Launto**, Turku (FI)

U.S. PATENT DOCUMENTS

(73) Assignee: **Maping Kommandiittiyhtiö L. Huotari**, Espoo (FI)

4,178,201	A	*	12/1979	Power et al.	D18/34.1
D263,970	S	*	4/1982	Wiholm	D18/34.1
D288,212	S	*	2/1987	Nordgren	D18/34.1
D296,566	S	*	7/1988	Hori	D18/34.1
4,818,168	A	*	4/1989	Battisti	412/37
5,035,561	A	*	7/1991	Loibl	412/33
5,073,076	A	*	12/1991	Parkhill et al.	412/33
D328,309	S	*	7/1992	Tu	D18/34.3
D352,955	S	*	11/1994	Nordgren	D18/34.1
RE34,917	E	*	4/1995	Parkhill et al.	412/33
7,354,232	B1	*	4/2008	Yeaple	412/8

(*) Notice: This patent is subject to a terminal disclaimer.

(**) Term: **14 Years**

* cited by examiner

(21) Appl. No.: **29/340,768**

Primary Examiner — Charles A Rademaker

(22) Filed: **Jul. 24, 2009**

(74) *Attorney, Agent, or Firm* — Bourque & Associates, P.A.

(30) **Foreign Application Priority Data**

(57) **CLAIM**

The ornamental design for a book binding machine, as shown and described.

Jan. 28, 2009 (DE) 40 2009 000 630

(51) **LOC (9) Cl.** **18-04**

(52) **U.S. Cl.** **D18/34.1**

(58) **Field of Classification Search** D18/34.1-34.9,
D18/99; 412/22, 23, 29, 32, 34; 281/46,
281/47, 51; 83/934, 933, 276; 270/45, 52.18,
270/58.08, 58.07; D14/420-425

DESCRIPTION

FIG. 1 is a front elevation of a book binding machine showing our new design;
FIG. 2 is a rear elevation thereof;
FIG. 3 is a top plan view thereof;
FIG. 4 is a bottom plan view thereof;
FIG. 5 is a right side elevation thereof;
FIG. 6 is a left side elevation thereof, and,
FIG. 7 is a front perspective view thereof.

See application file for complete search history.

1 Claim, 7 Drawing Sheets

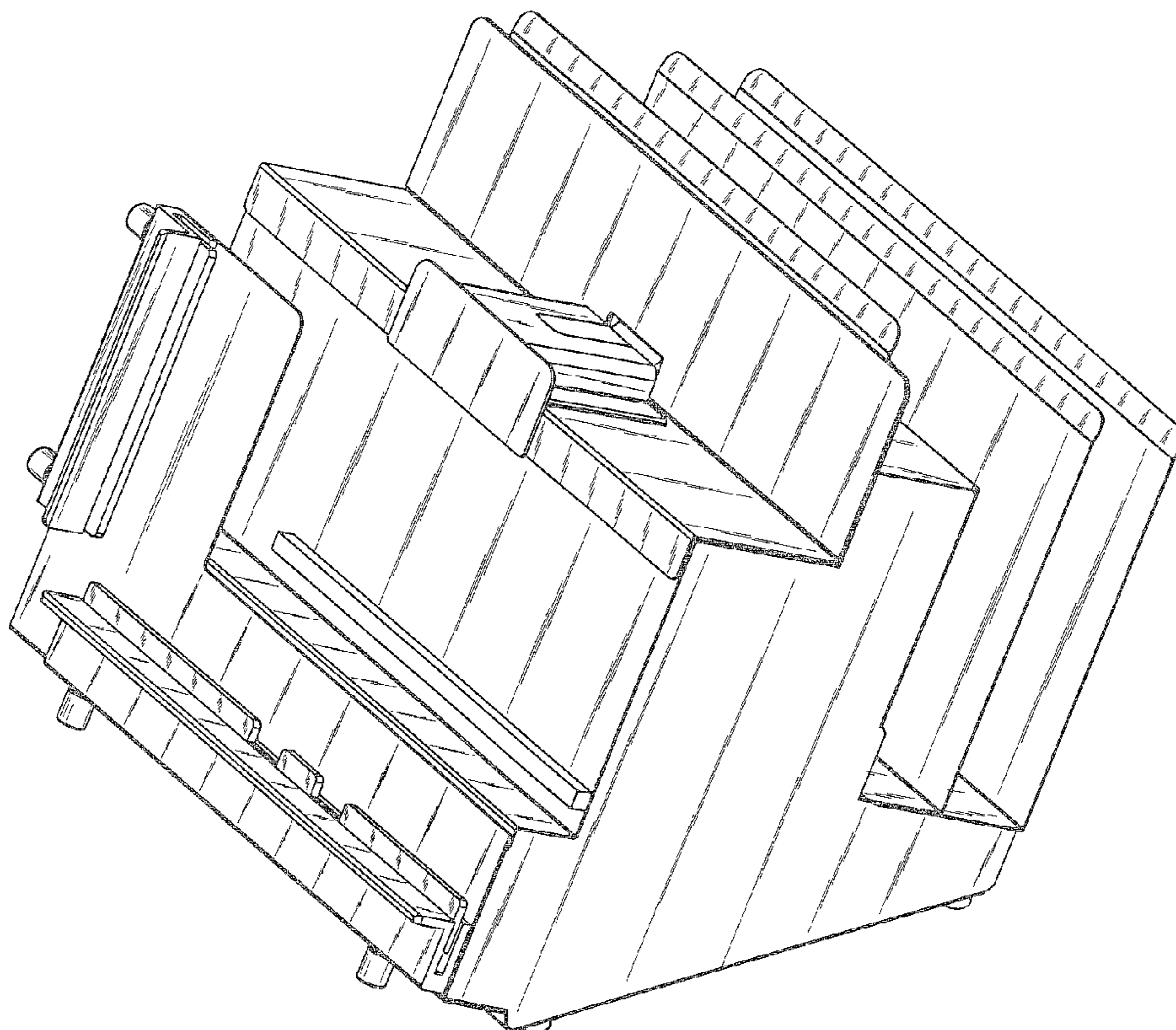

FIG 1

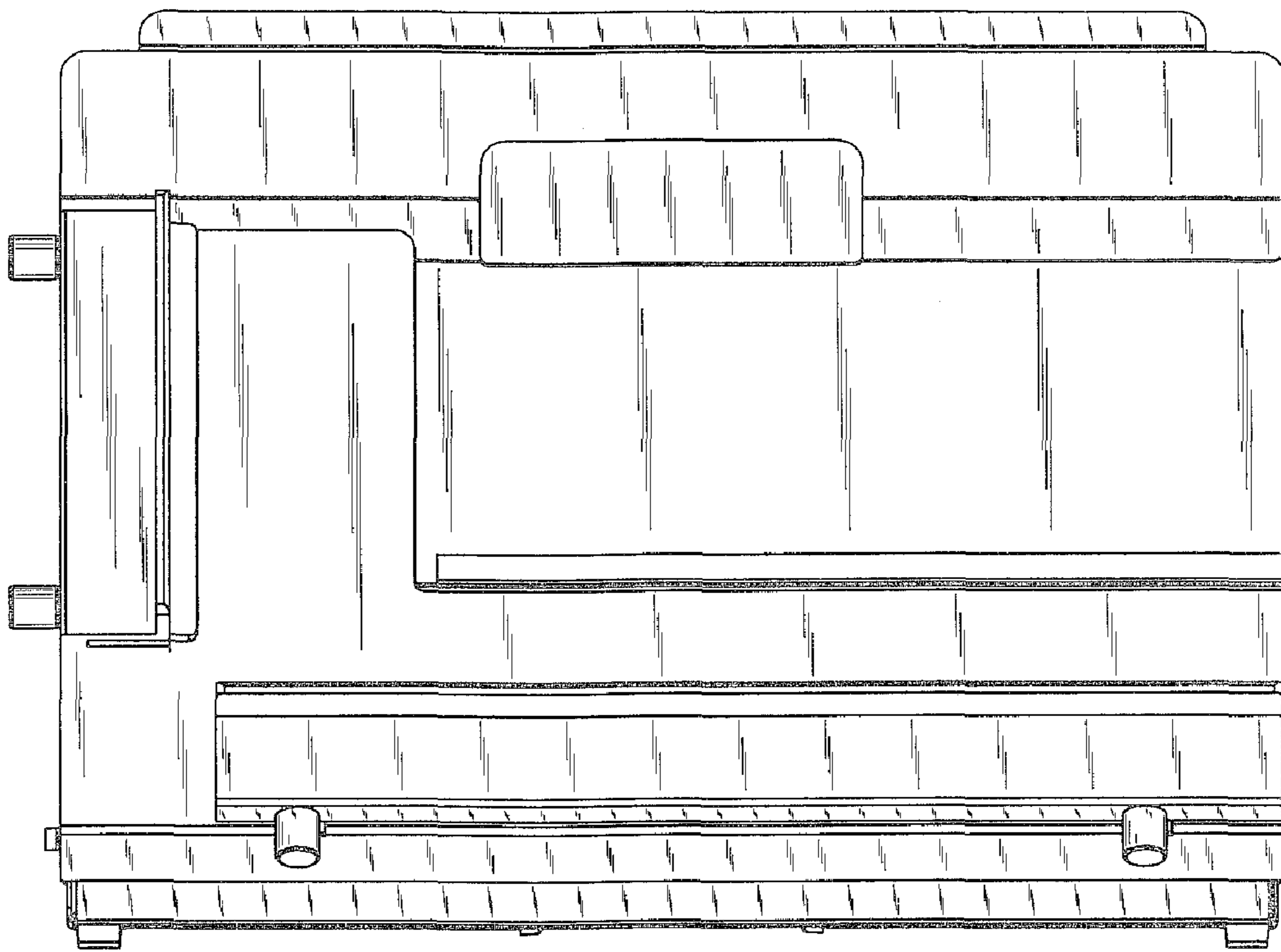

FIG 2

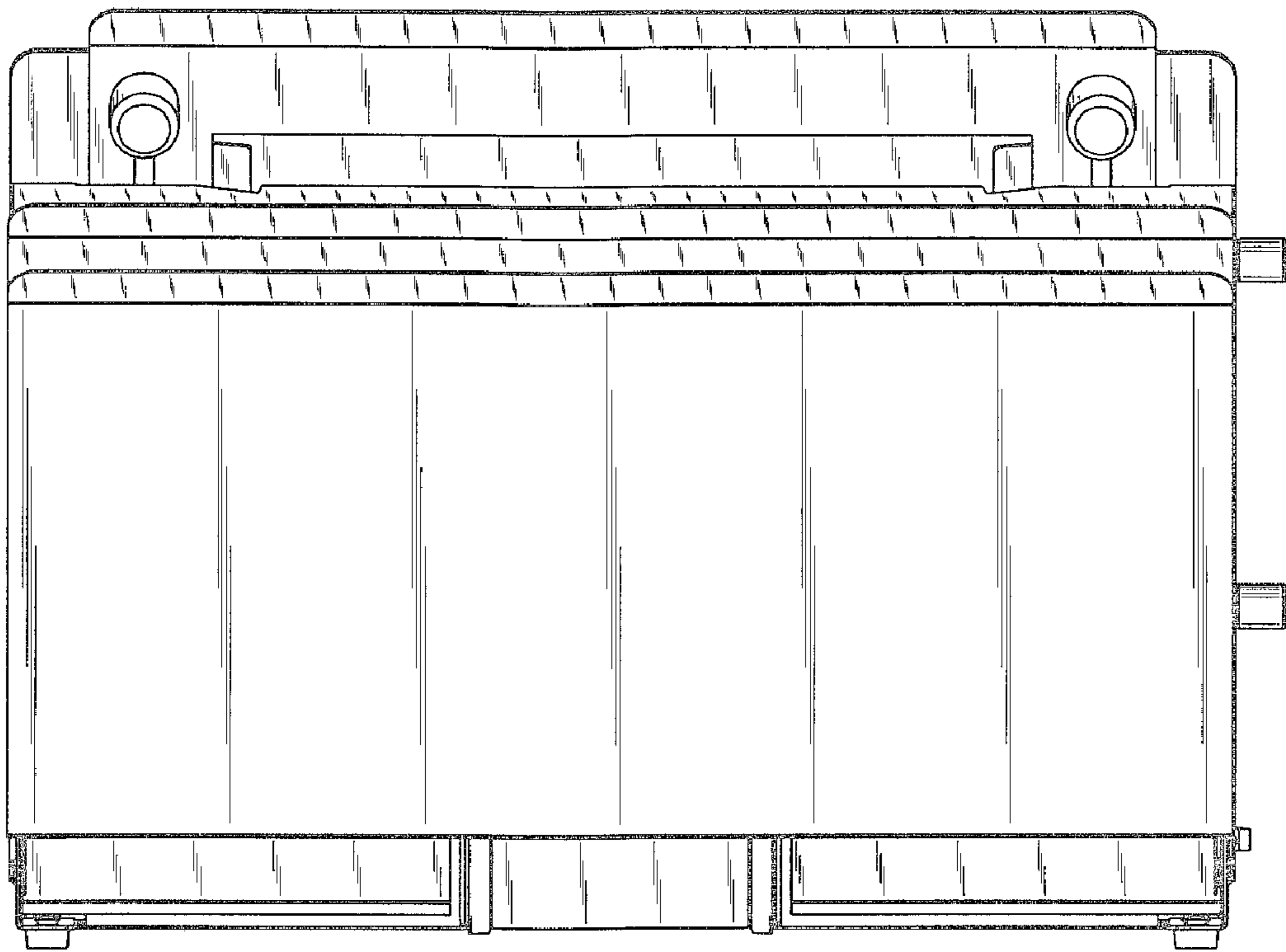

FIG 3

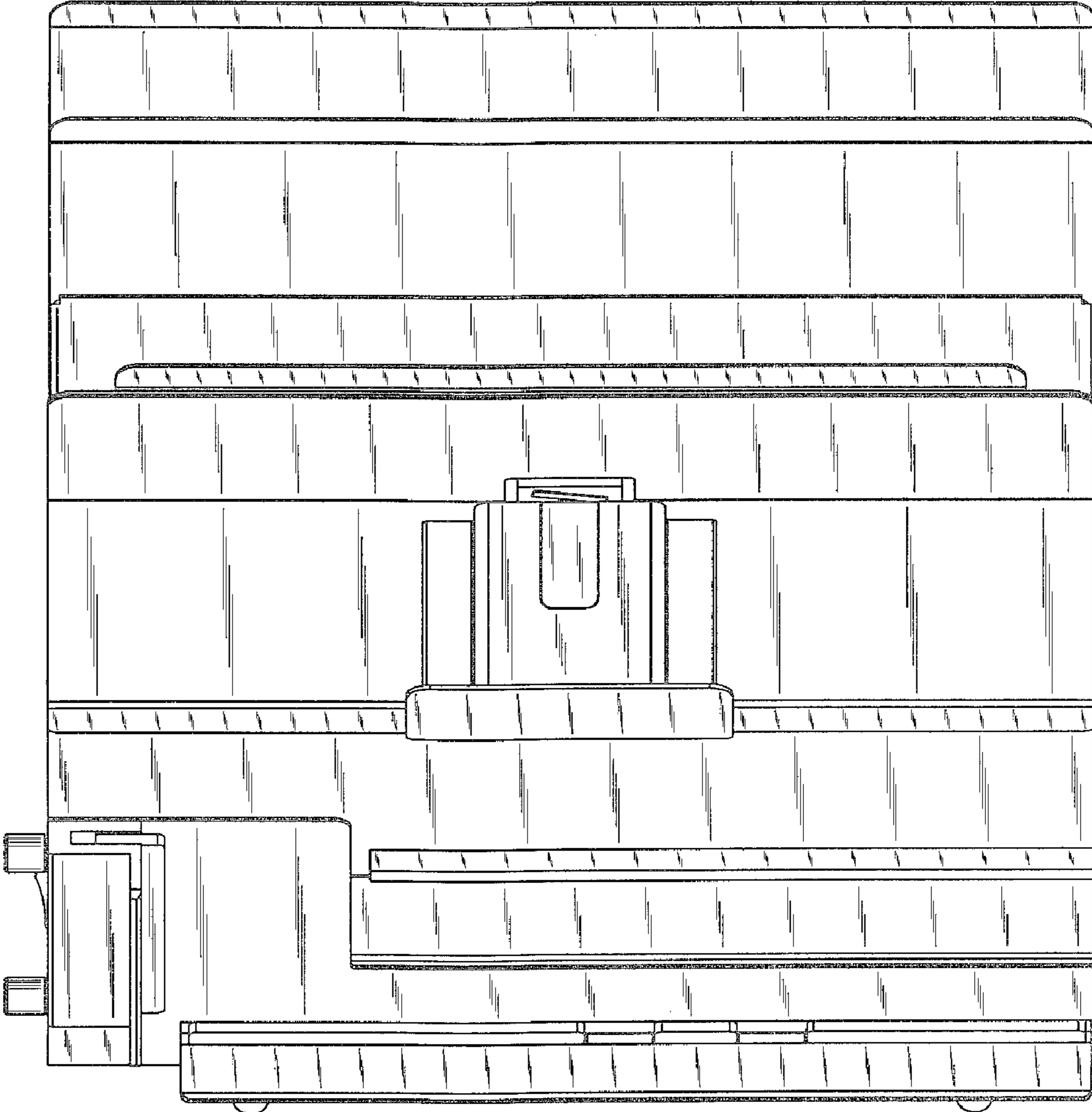

FIG 4

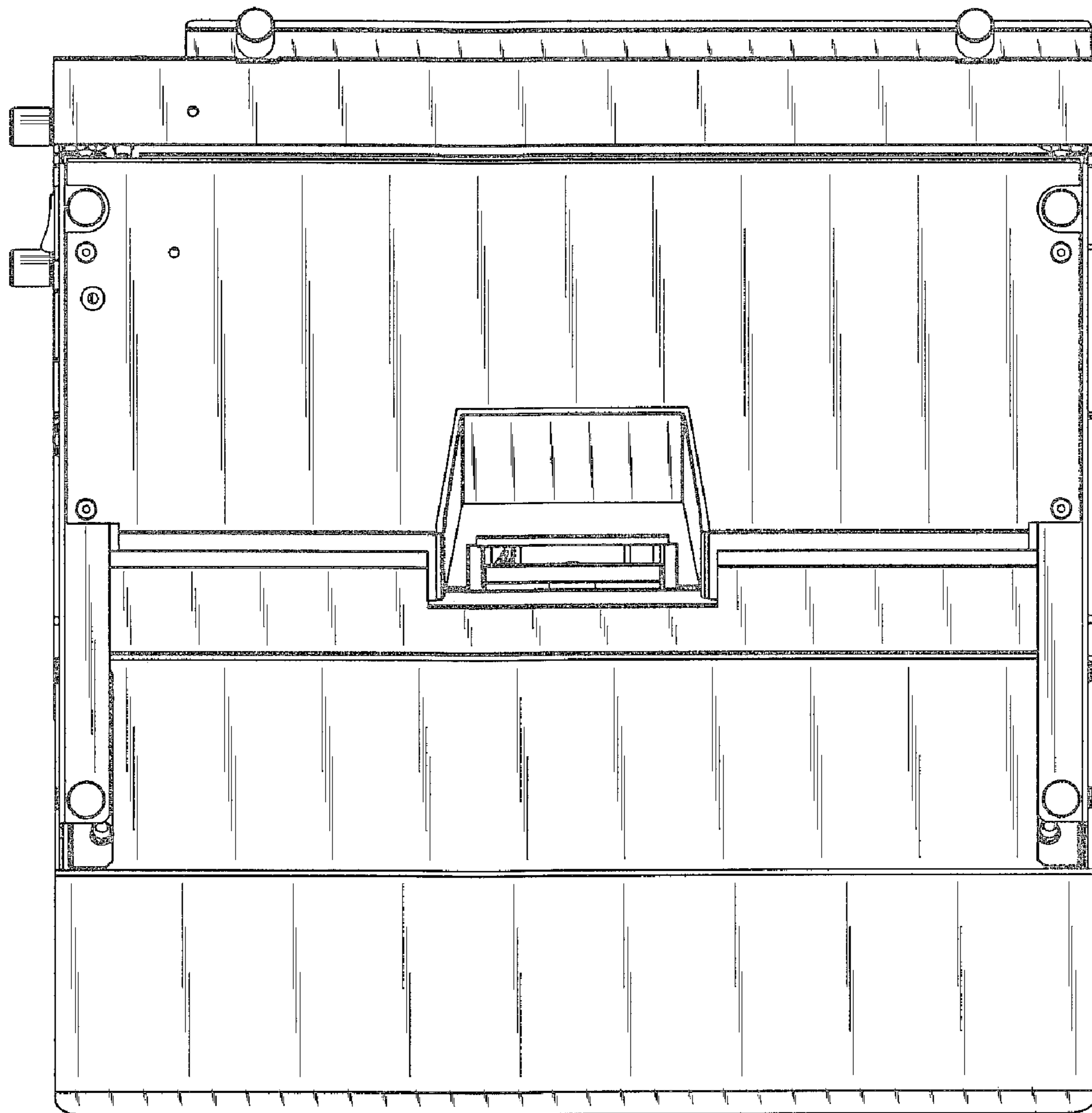

FIG 5

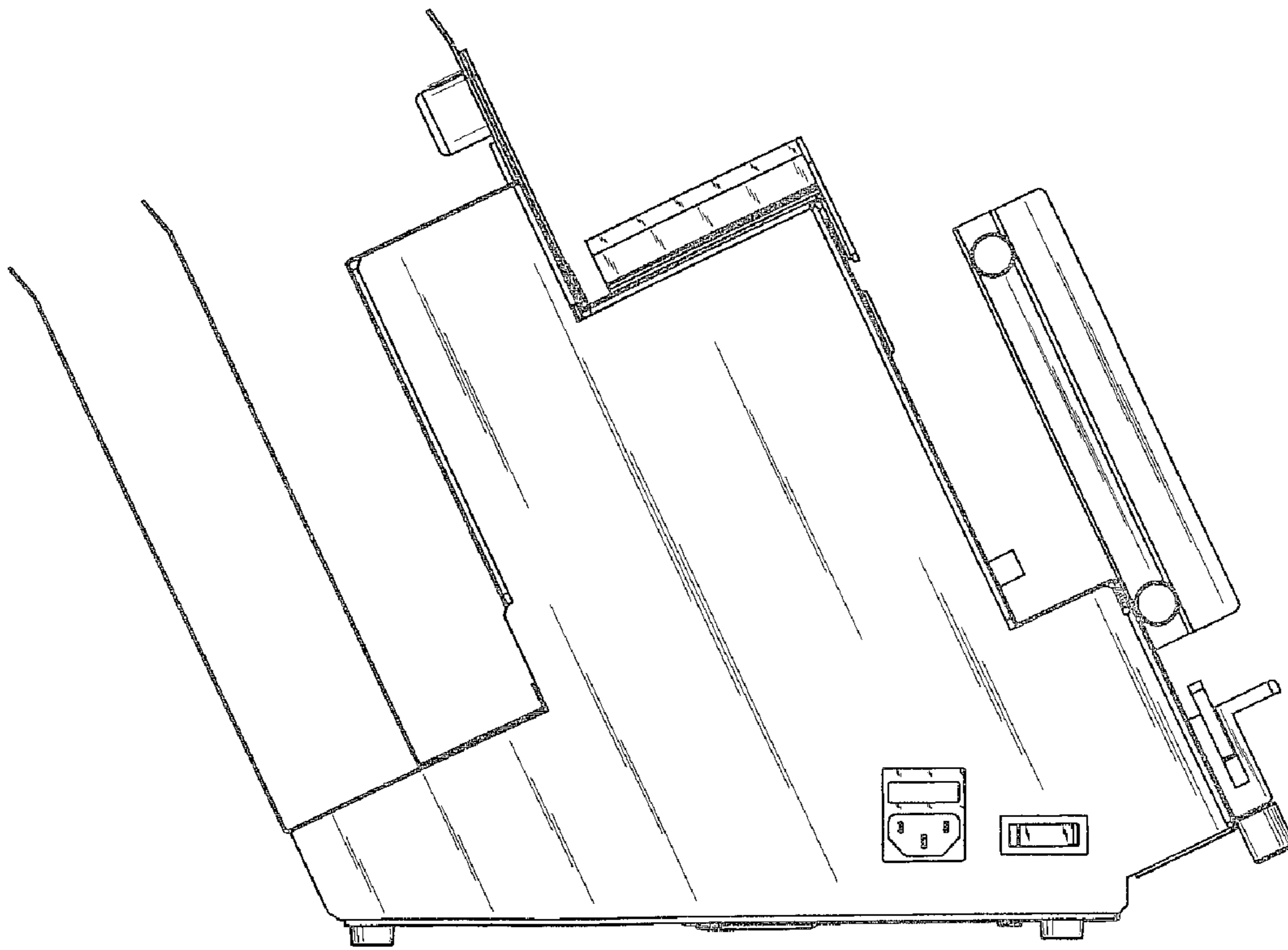

FIG 6

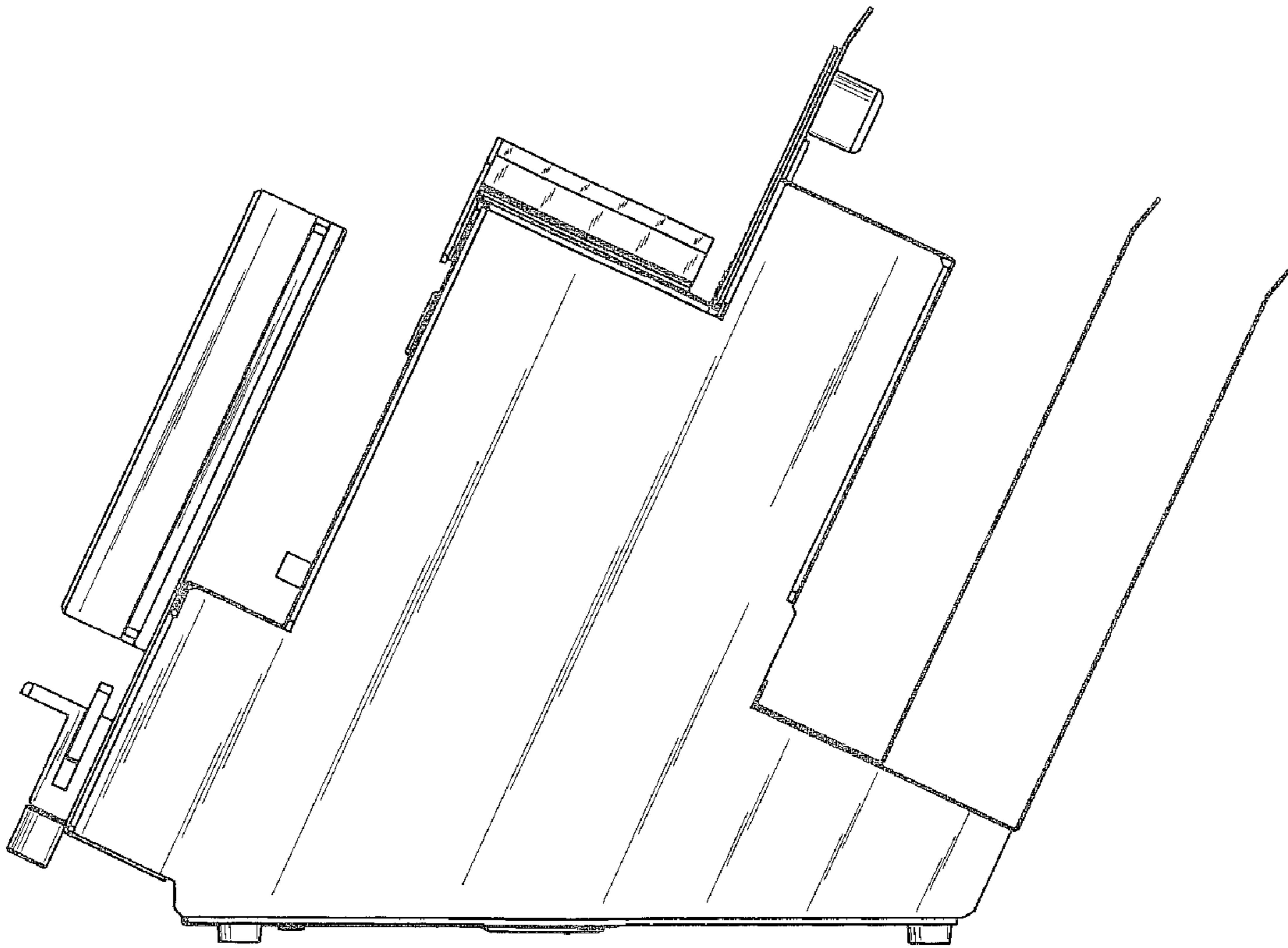

FIG 7

