



US00D636431S

(12) **United States Design Patent**
Harmon

(10) **Patent No.:** **US D636,431 S**

(45) **Date of Patent:** **** Apr. 19, 2011**

(54) **GUITAR BODY**

(76) Inventor: **Thomas Henry Harmon**, Vancouver,
WA (US)

(**) Term: **14 Years**

(21) Appl. No.: **29/349,443**

(22) Filed: **Apr. 5, 2010**

(51) **LOC (9) Cl.** **17-03**

(52) **U.S. Cl.** **D17/14**

(58) **Field of Classification Search** D17/14,
D17/18; 84/267, 290-292

See application file for complete search history.

(56) **References Cited**

U.S. PATENT DOCUMENTS

3,072,007	A *	1/1963	Burke	84/267
D299,453	S *	1/1989	Brunet	D17/20
D441,004	S *	4/2001	Kondo	D17/14
6,667,431	B1 *	12/2003	Norman	84/290
6,855,879	B2 *	2/2005	Minakuchi et al.	84/327
D518,504	S *	4/2006	Sawhney et al.	D17/14
D527,409	S *	8/2006	Harrington	D17/20
D539,835	S *	4/2007	Brugal	D17/20
D544,767	S *	6/2007	Kelleghan	D8/38
7,507,885	B2 *	3/2009	Coke	84/291
2008/0202309	A1 *	8/2008	Wiswell	84/291

* cited by examiner

Primary Examiner — Ian Simmons
Assistant Examiner — Rashida Johnson

(57) **CLAIM**

The ornamental design for a guitar body, as shown and described.

DESCRIPTION

FIG. 1 is a front elevational view of the guitar body in its assembled state showing my new design;
 FIG. 2 is the back view thereof;
 FIG. 3 is a left side view of FIG. 1;
 FIG. 4 is a right side view thereof;
 FIG. 5 is a bottom plan view thereof;
 FIG. 6 is a top plan view thereof;
 FIG. 7 is an exploded view of FIG. 1; showing the guitar body unassembled;
 FIG. 8 is a front view of the guitar body in use; showing the right side section of the guitar body moved backward in an alternate position; and,
 FIG. 9 is a front view of the guitar body in use; showing the right side section of the guitar body moved forward in an alternate position.
 The broken lines, shown in FIGS. 2, 5 and 7, represent the portions of the design, which form no part of the claim.

1 Claim, 4 Drawing Sheets

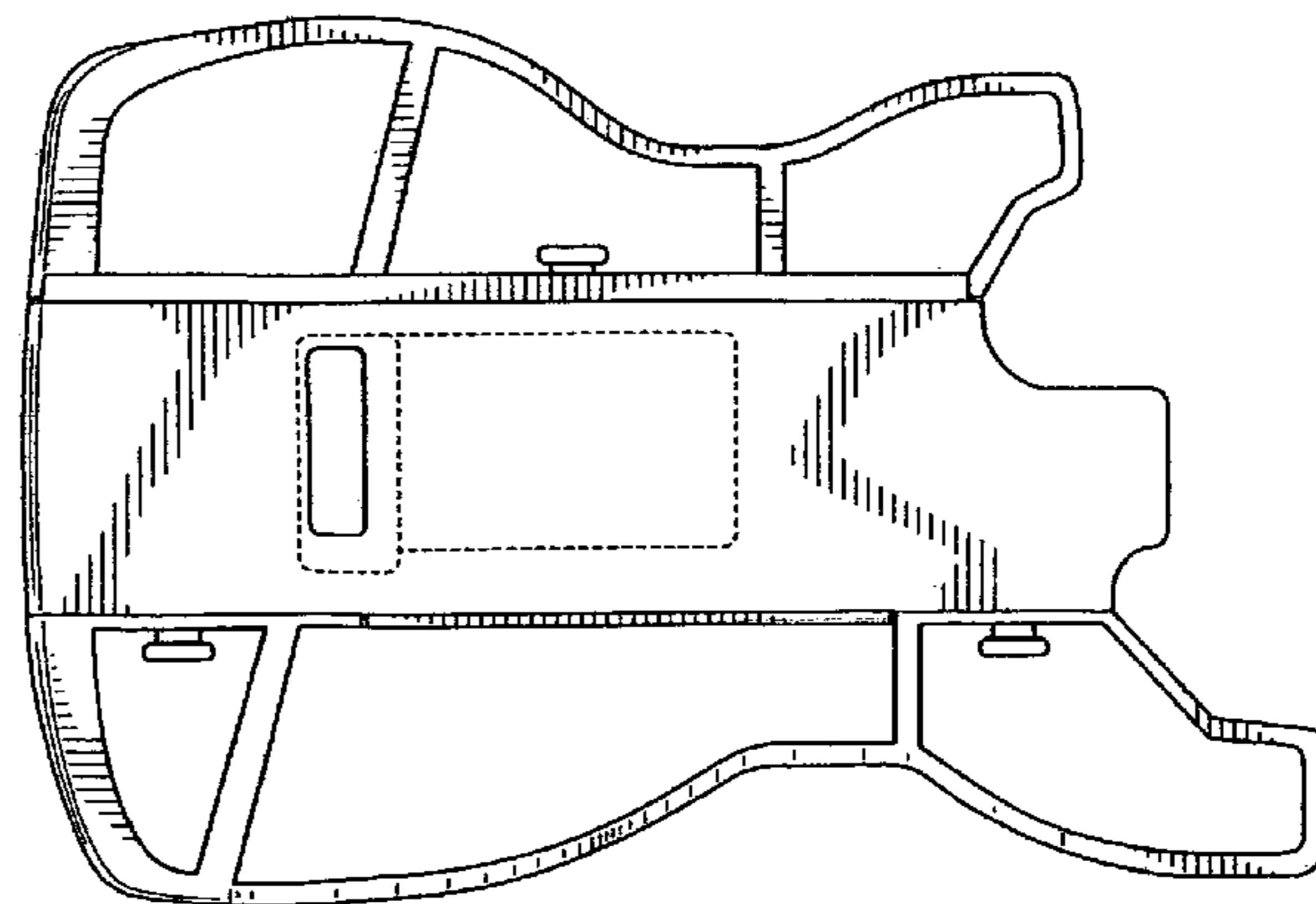
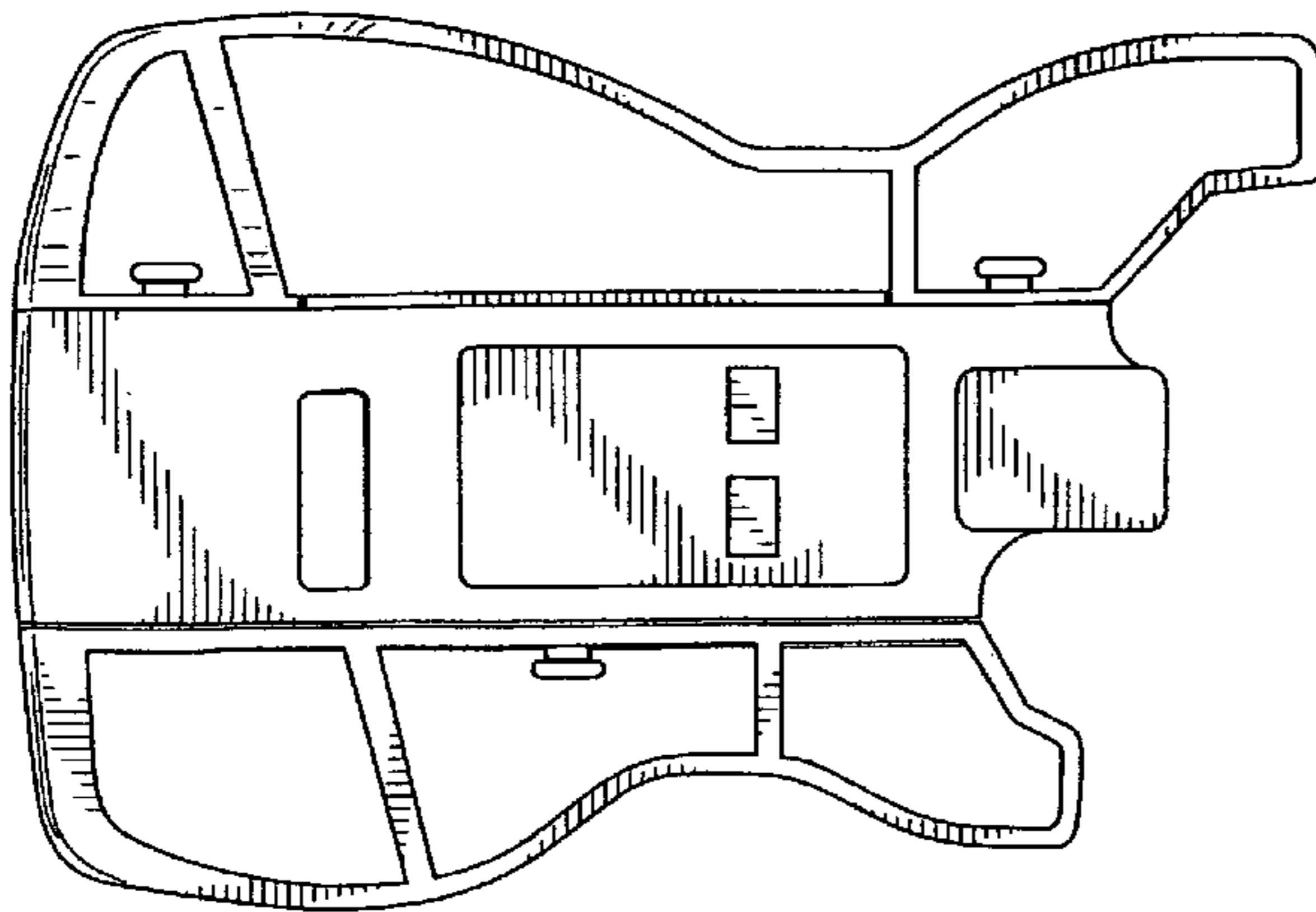

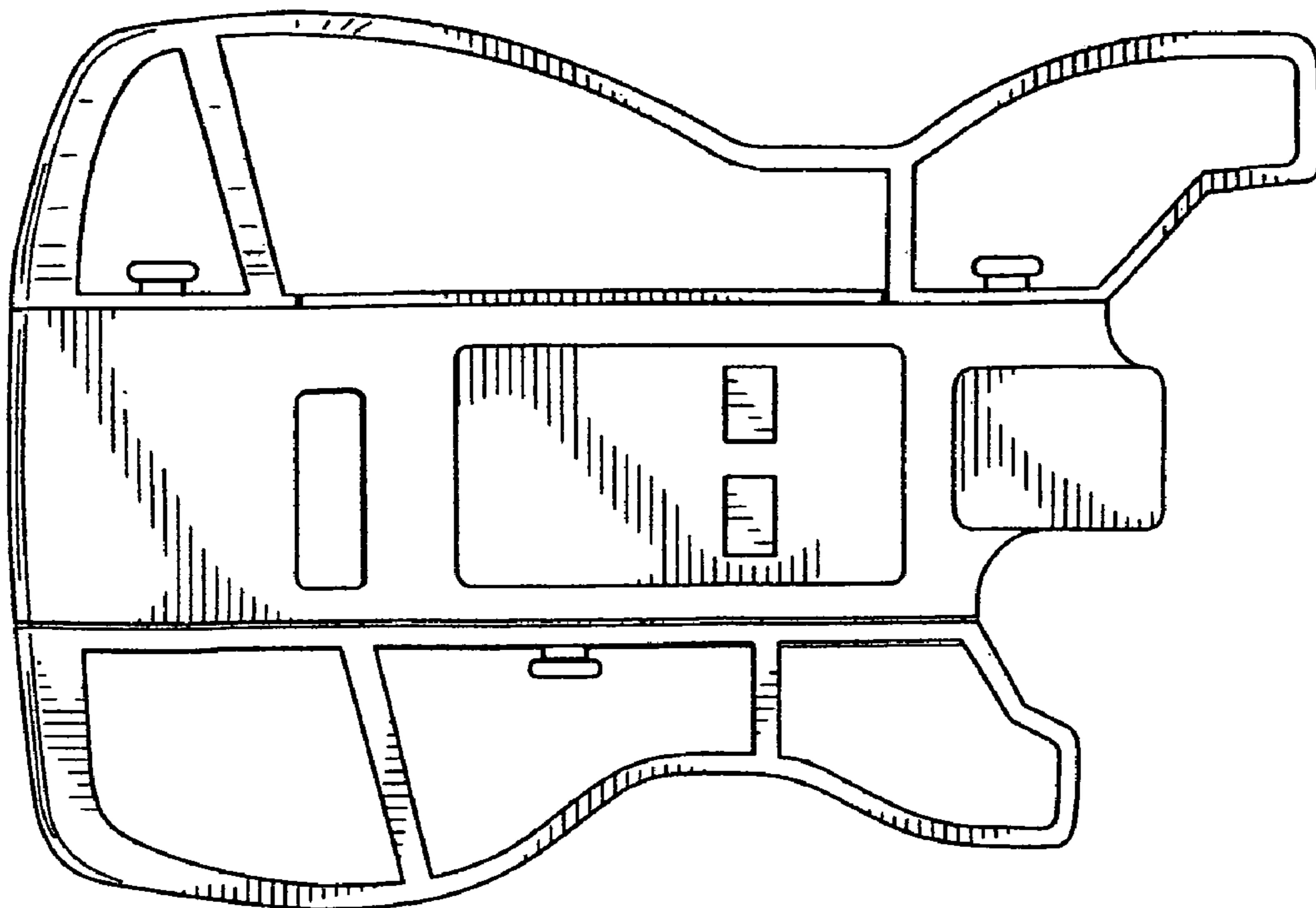

FIG. 1

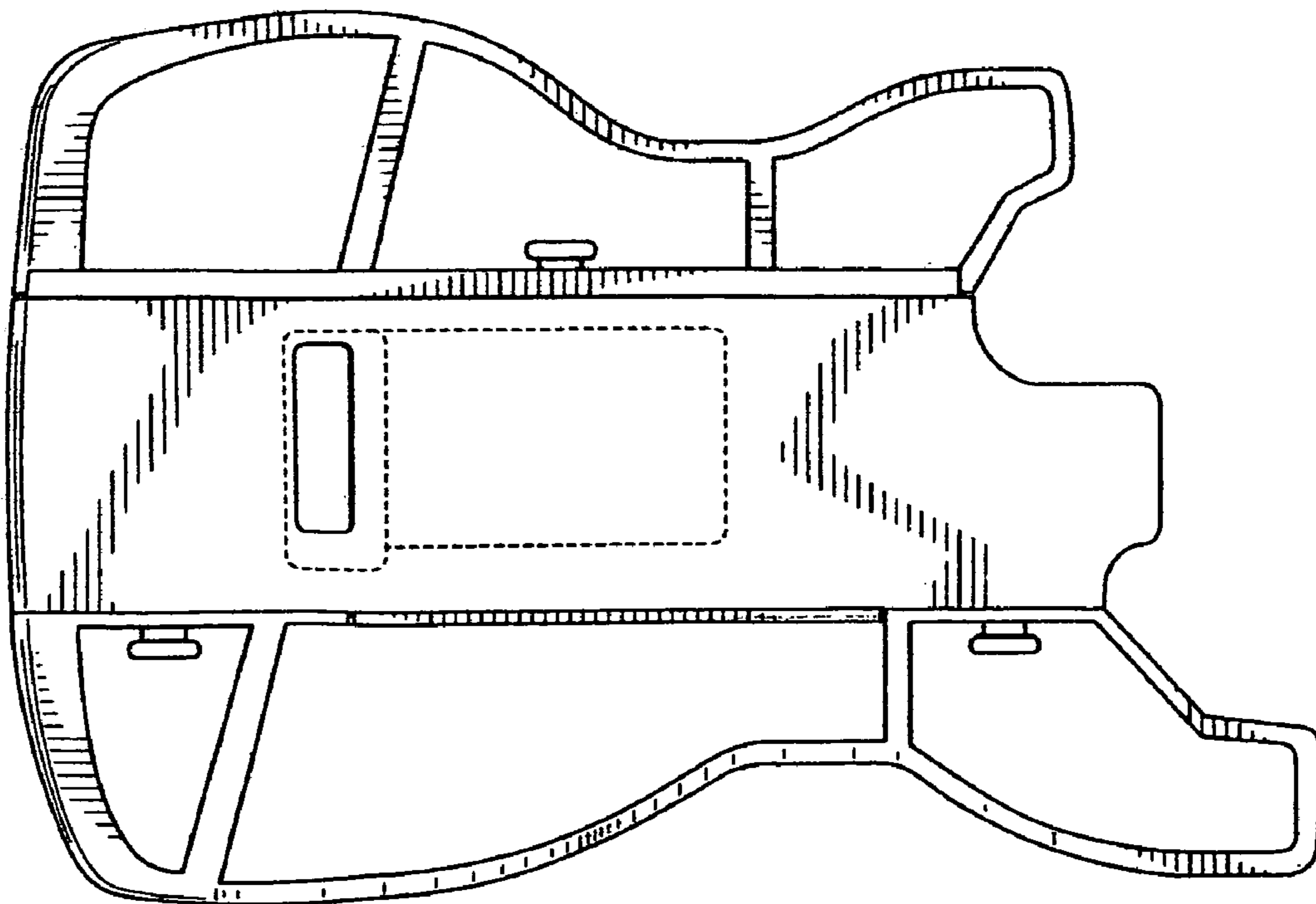

FIG. 2

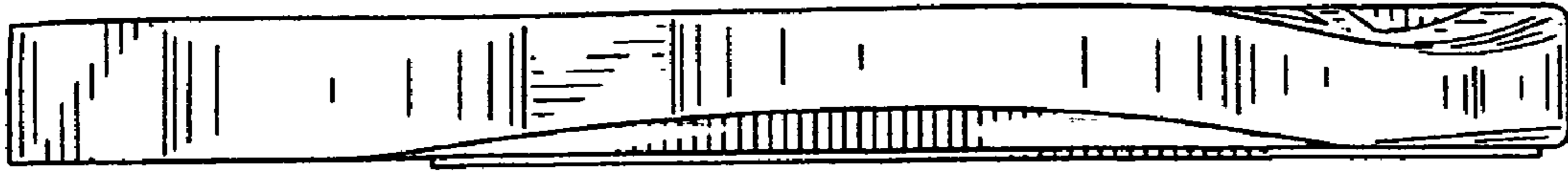

FIG. 3

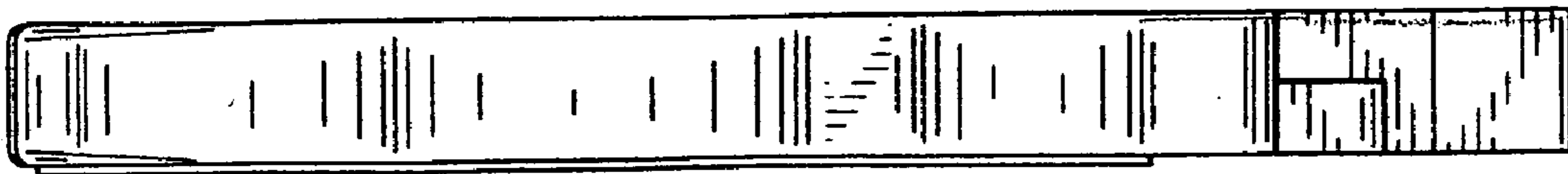

FIG. 4

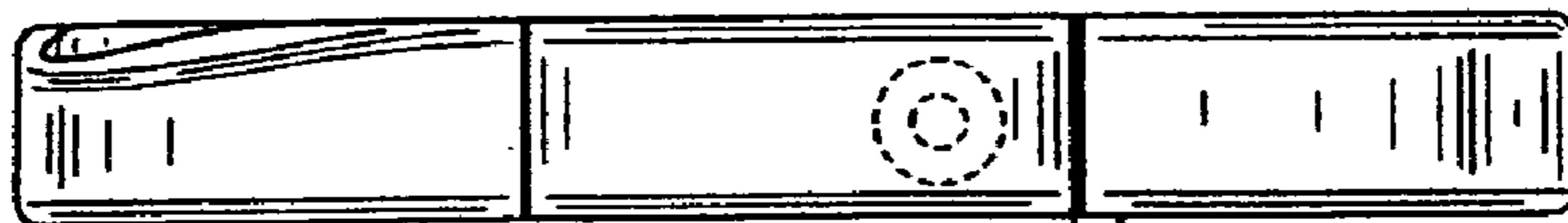

FIG. 5



FIG. 6

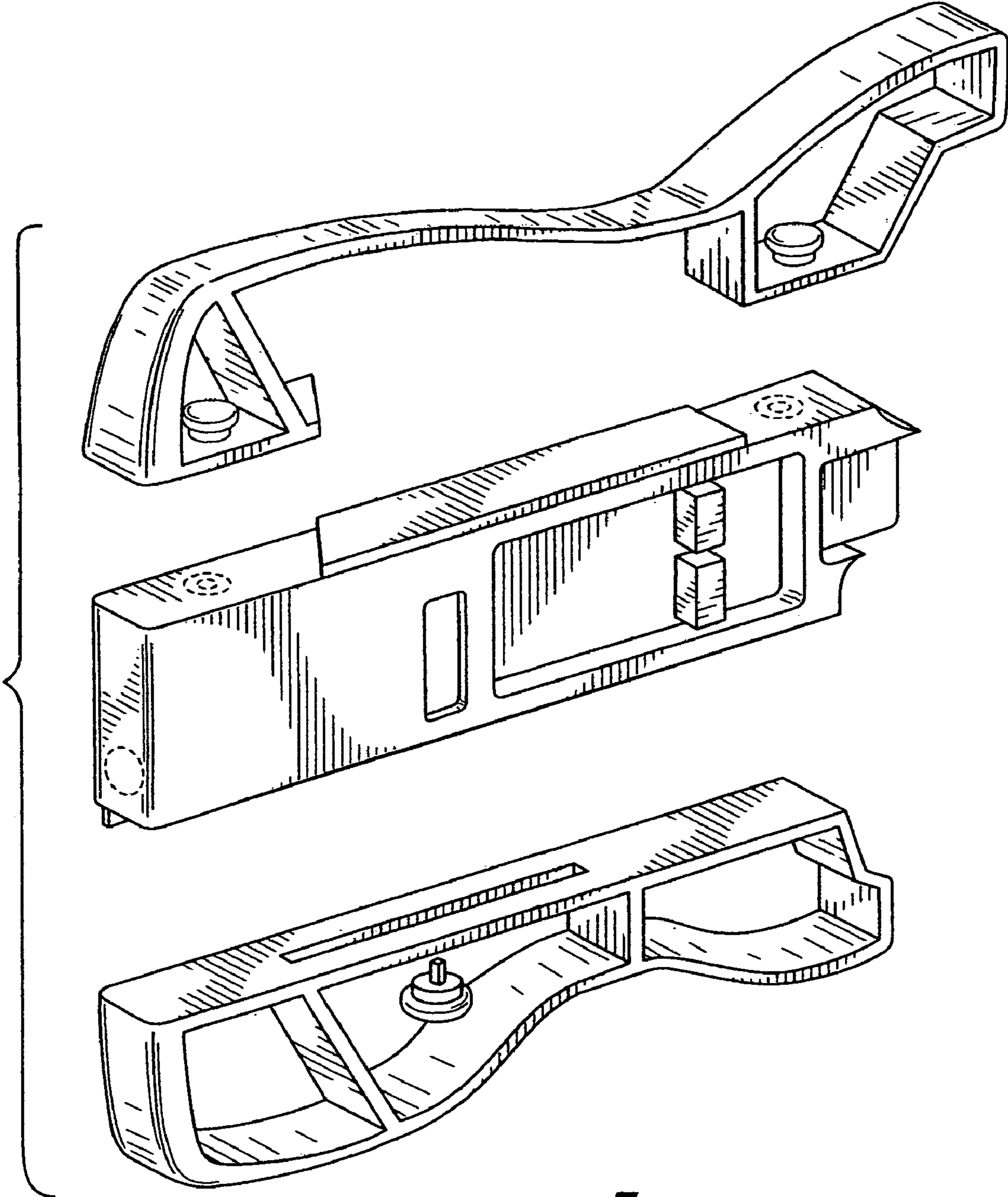

FIG. 7

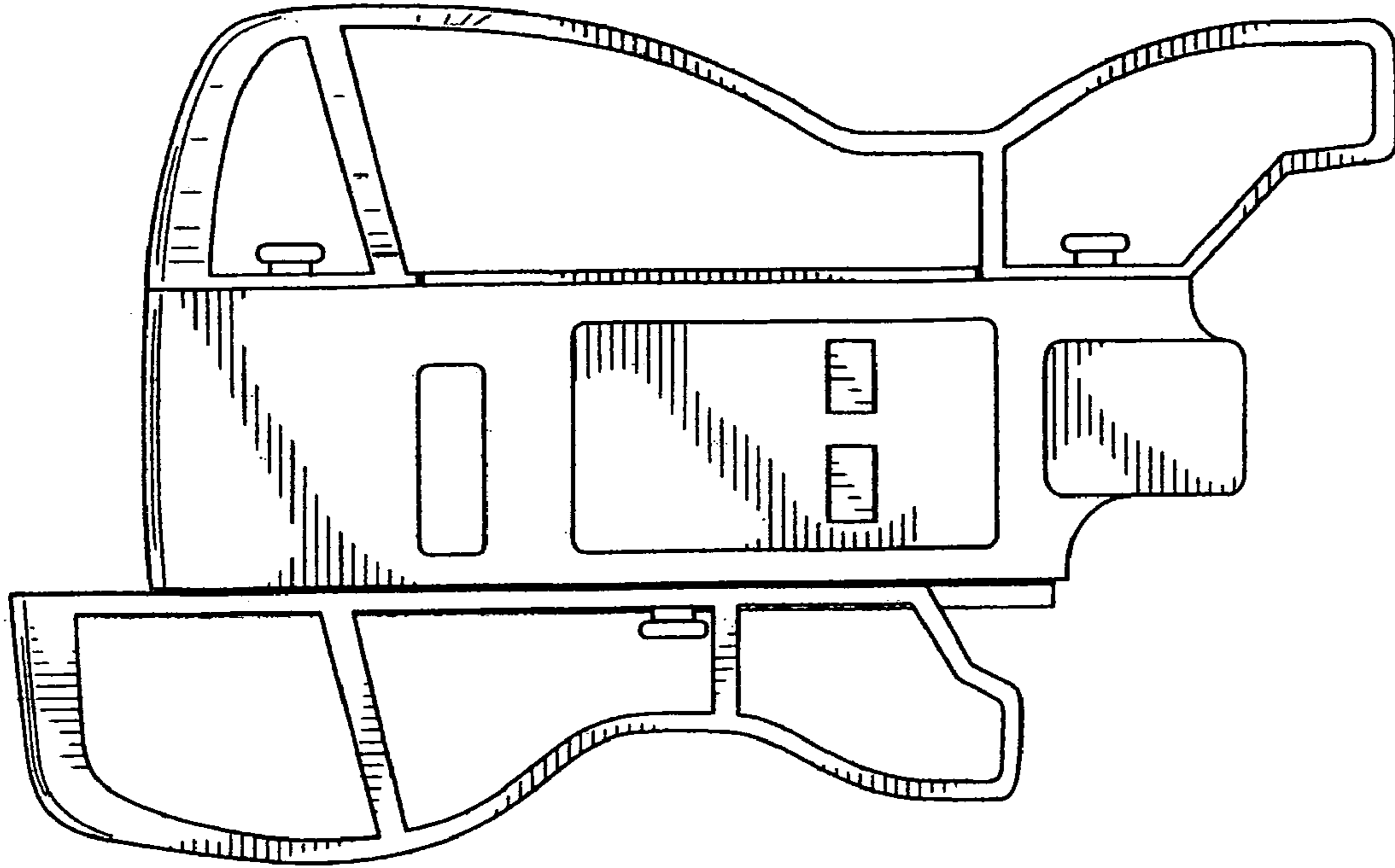

FIG. 8

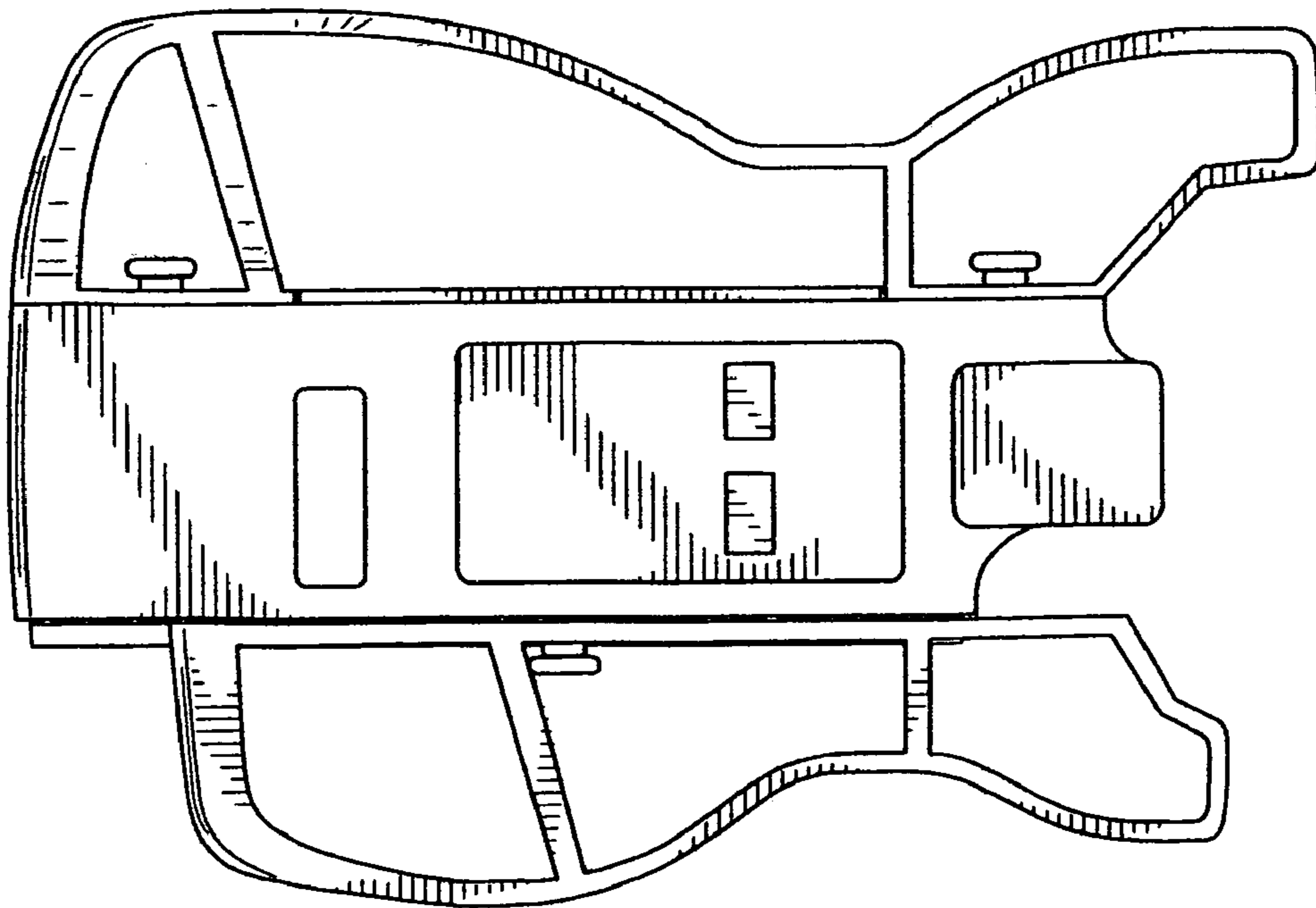

FIG. 9