



US00D636408S

(12) **United States Design Patent**  
**Luxon et al.**

(10) **Patent No.:** **US D636,408 S**

(45) **Date of Patent:** **\*\* Apr. 19, 2011**

(54) **AIR IN TAKE SNORKEL FOR A VEHICLE**

(75) Inventors: **Peter Luxon**, South Croydon (AU);  
**Manvir Randhawa**, South Croydon (AU)

(73) Assignee: **Australian Performance Development Pty Ltd.**, South Croydon VIC (AU)

(\*\*) Term: **14 Years**

(21) Appl. No.: **29/347,783**

(22) Filed: **Jun. 4, 2010**

(30) **Foreign Application Priority Data**

Dec. 4, 2009 (AU) ..... 14733/2009

(51) **LOC (9) Cl.** ..... **15-01**

(52) **U.S. Cl.** ..... **D15/5; D12/400**

(58) **Field of Classification Search** ..... D15/1-6;  
123/184.21, 184.24, 184.34, 184.35, 23.2,  
123/184.48, 184.42; D12/400, 194, 206,  
D12/418; D24/110.5, 110.6

See application file for complete search history.

(56) **References Cited**

U.S. PATENT DOCUMENTS

6,564,766	B2 *	5/2003	Ayton	.....	123/184.21
6,637,537	B2 *	10/2003	Porter et al.	.....	180/309
6,966,292	B2 *	11/2005	Huang	.....	123/184.21
D532,019	S *	11/2006	Huang	.....	D15/5
D545,725	S *	7/2007	Zimbaro	.....	D12/114
7,281,511	B2 *	10/2007	Quezada	.....	123/184.53
D562,749	S *	2/2008	LaRussa	.....	D12/194

7,685,985	B2 *	3/2010	Madeira	.....	123/184.21
D627,369	S *	11/2010	Troxell	.....	D15/5
2002/0179030	A1 *	12/2002	Fiesel et al.	.....	123/184.42
2003/0019456	A1 *	1/2003	Ayton	.....	123/184.21
2006/0185639	A1 *	8/2006	Rosenbaum	.....	123/184.21
2006/0196462	A1 *	9/2006	Quezada	.....	123/184.21
2010/0083928	A1 *	4/2010	Saito et al.	.....	123/184.56
2010/0229817	A1 *	9/2010	Hirai	.....	123/184.21
2010/0229818	A1 *	9/2010	Silvano	.....	123/184.21

\* cited by examiner

*Primary Examiner* — T. Chase Nelson

*Assistant Examiner* — Ania K Dworzecka

(74) *Attorney, Agent, or Firm* — Duane Morris LLP

(57) **CLAIM**

The ornamental design for an air intake snorkel for a vehicle, as shown and described.

**DESCRIPTION**

FIG. 1 is a front left perspective view of the air intake snorkel for a vehicle of the present invention.

FIG. 2 is front right perspective view of the present invention.

FIG. 3 is a left side perspective view of the present invention.

FIG. 4 is a right side perspective view of the present invention.

FIG. 5 is a front elevational view of the present invention.

FIG. 6 is a rear elevational view of the present invention.

FIG. 7 is a top plan view of the present invention; and,

FIG. 8 is a bottom plan view of the present invention.

The broken lines showing environmental structure are for illustrative purposes only and form no part of the claimed design.

**1 Claim, 8 Drawing Sheets**

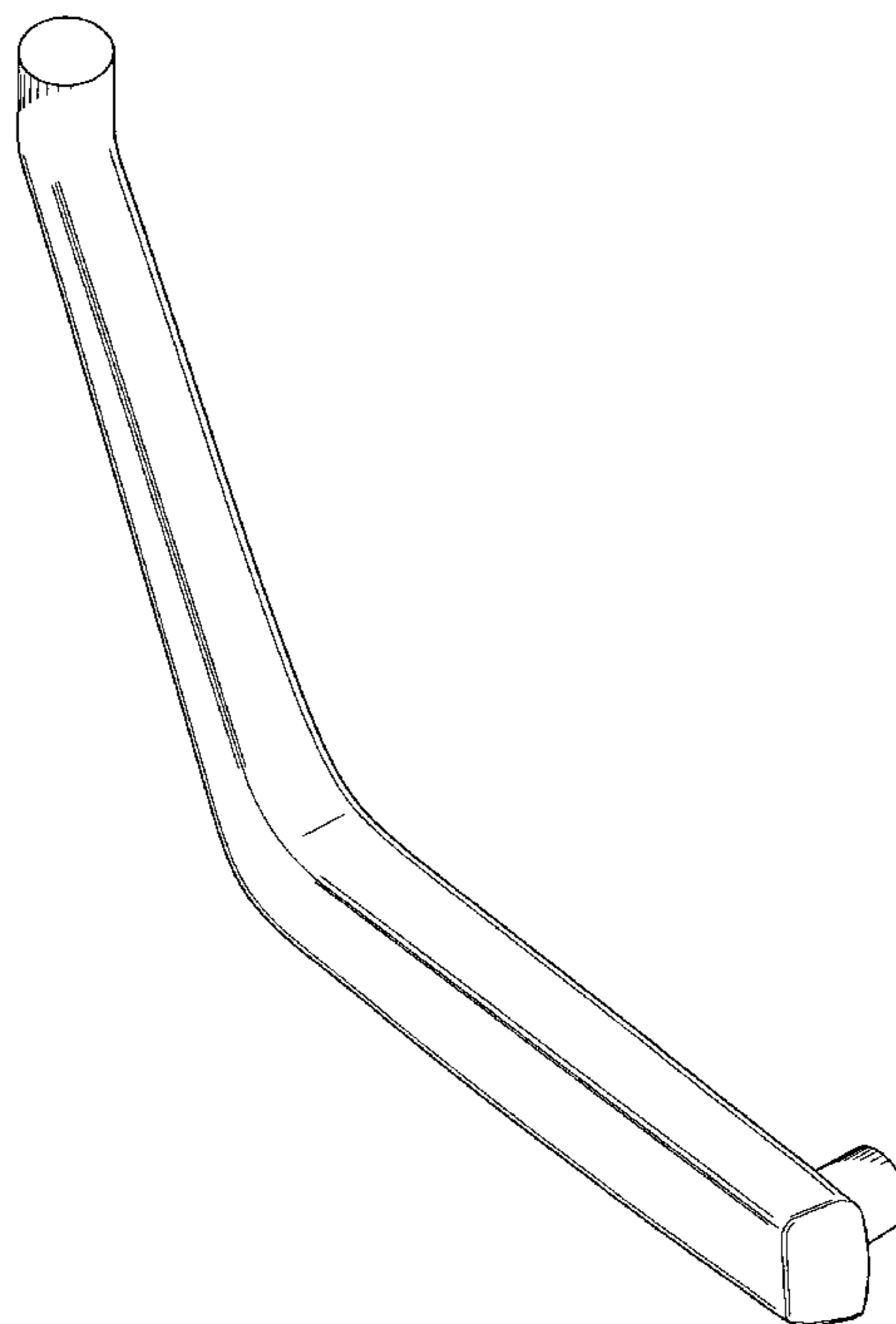

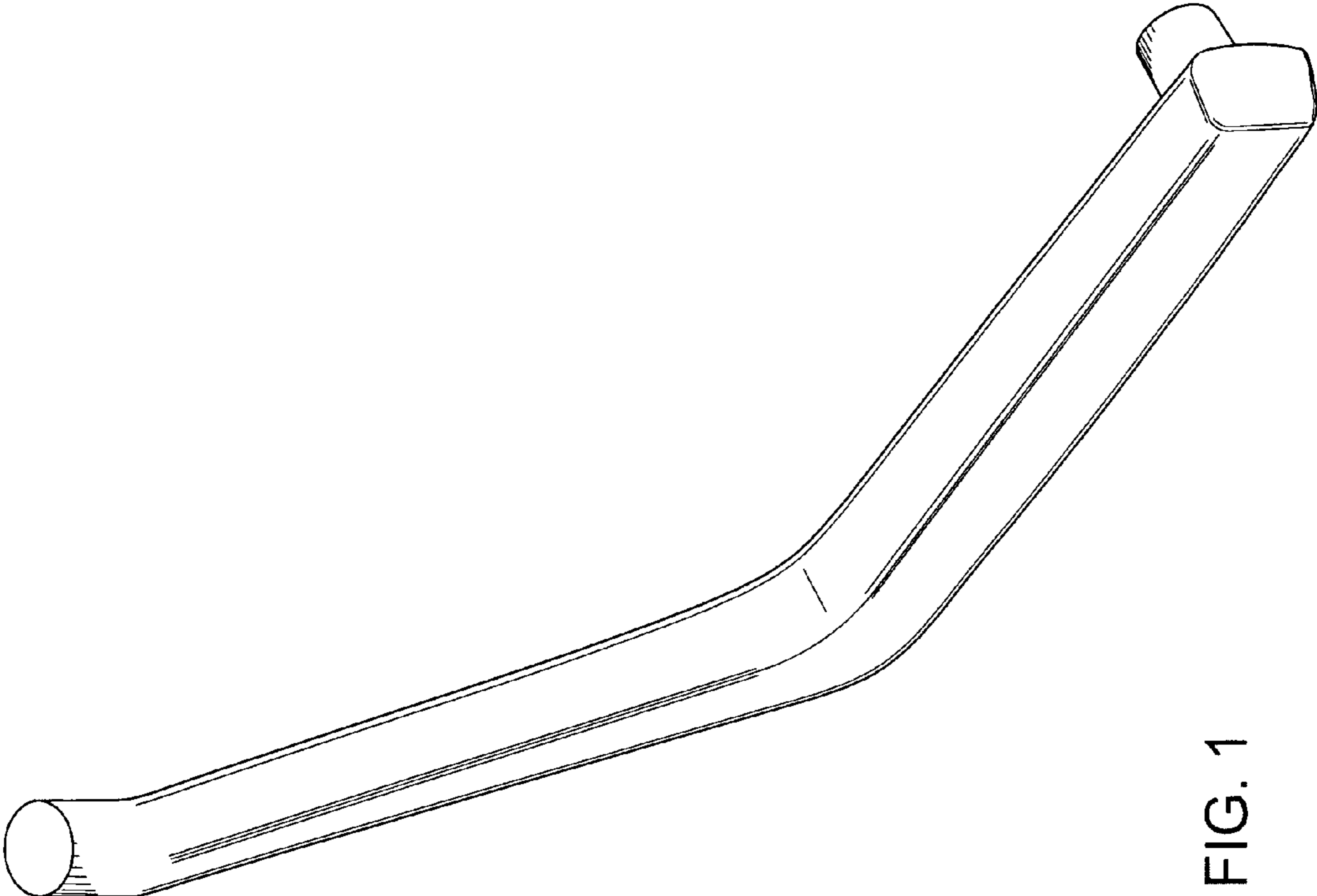

FIG. 1

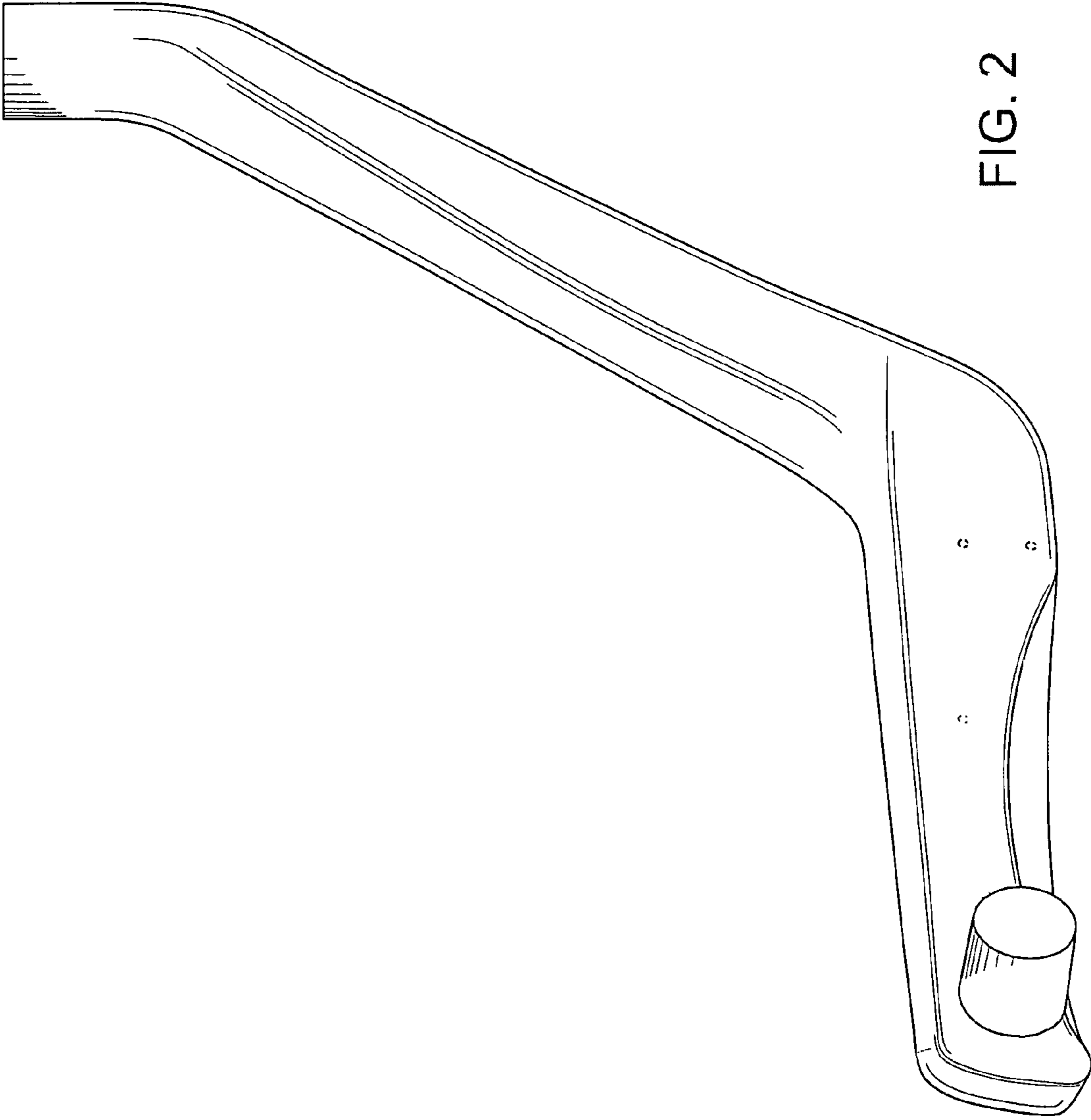

FIG. 2

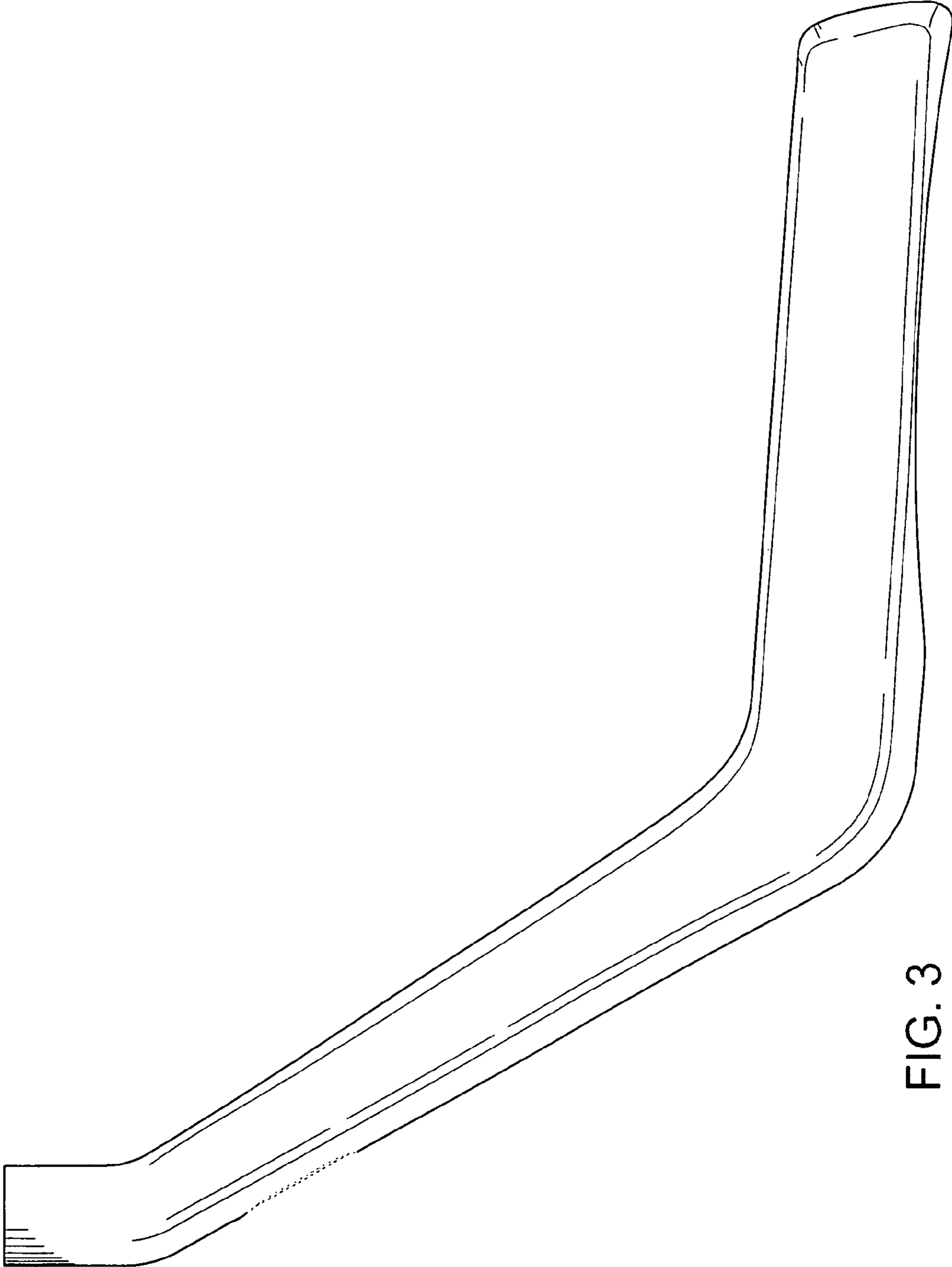

FIG. 3

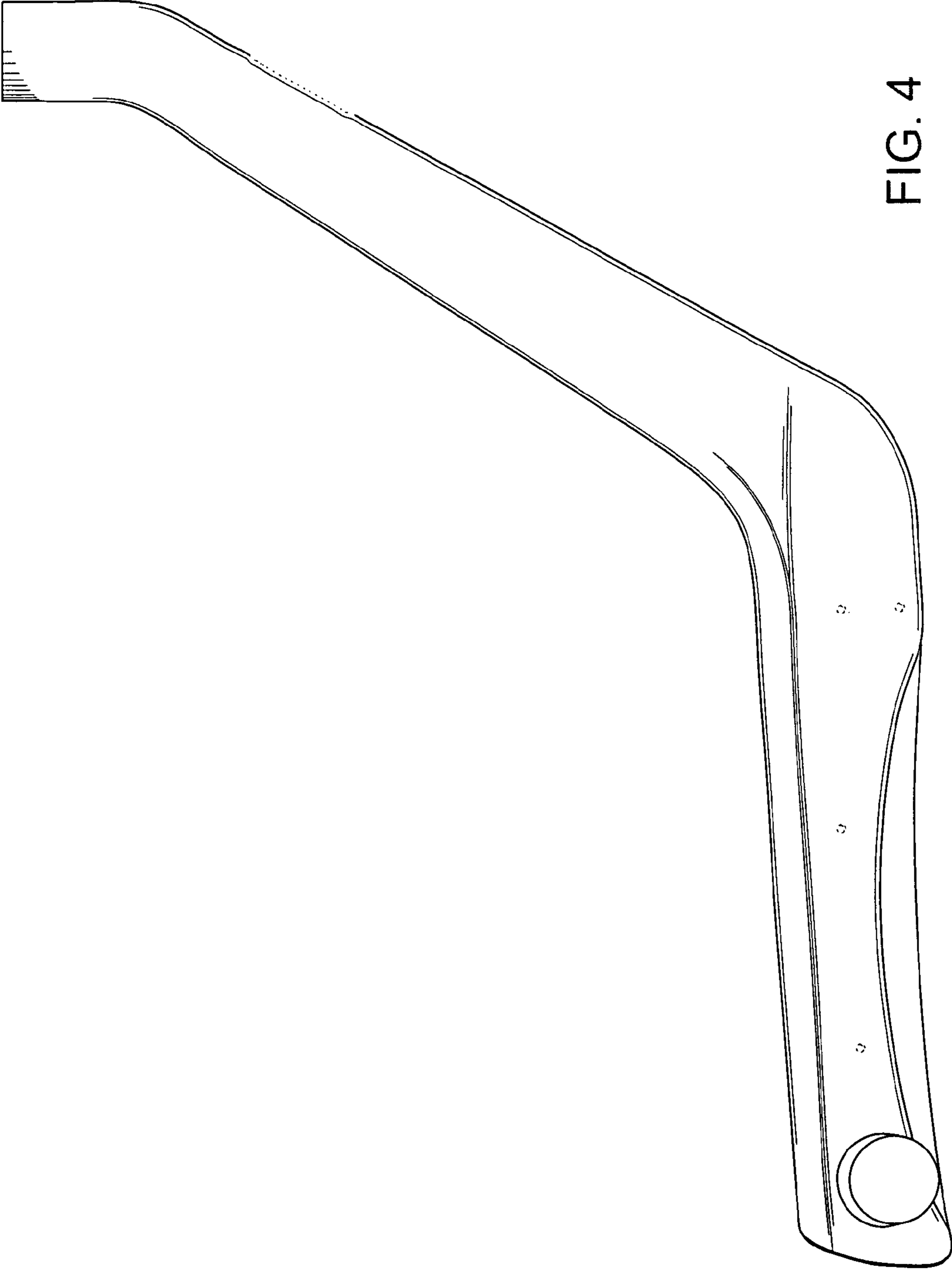

FIG. 4

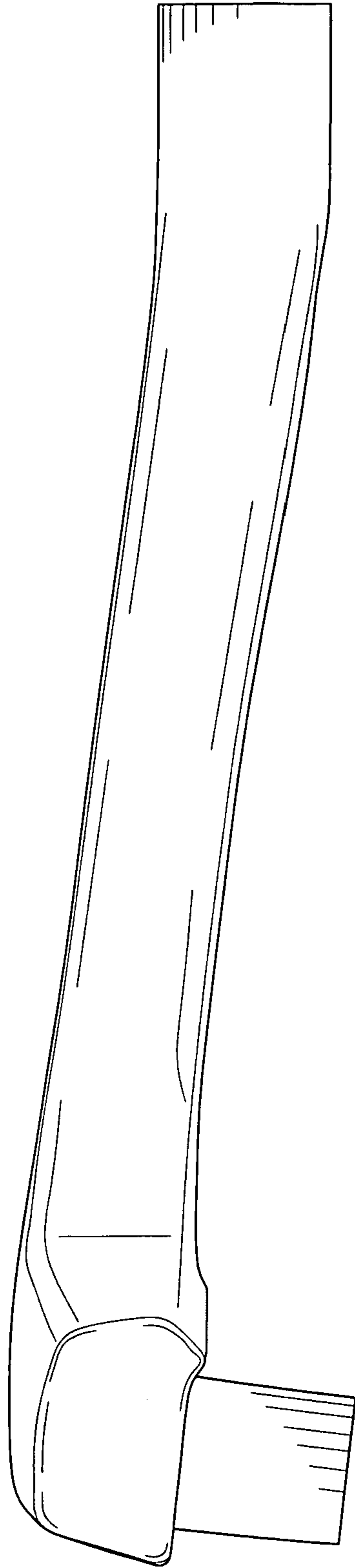

FIG. 5

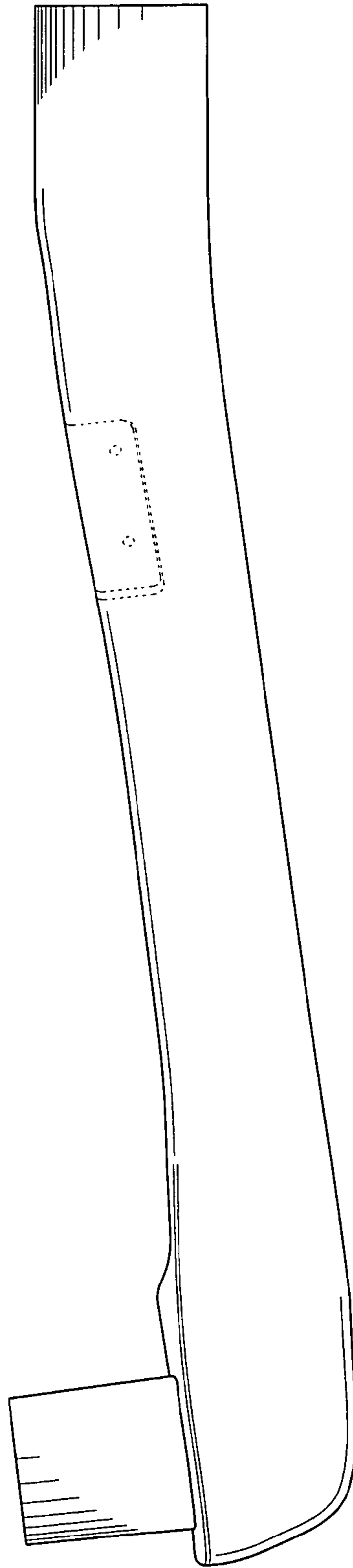

FIG. 6

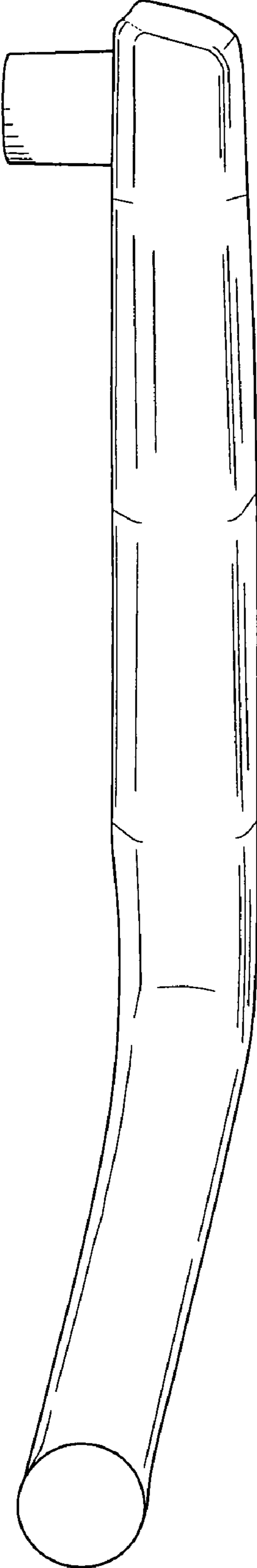

FIG. 7





FIG. 8