



US00D636141S

(12) **United States Design Patent**
Lupold

(10) **Patent No.:** **US D636,141 S**
(45) **Date of Patent:** **** Apr. 12, 2011**

(54) **LIFTING APPARATUS**

(75) Inventor: **Wilhelm Lupold**, Vöhringen (DE)

(73) Assignee: **Andreas Lupold Hydrotechnik GmbH**,
Voehringen (DE)

(**) Term: **14 Years**

(21) Appl. No.: **29/309,554**

(22) Filed: **Sep. 2, 2008**

(30) **Foreign Application Priority Data**

Mar. 1, 2008 (DE) 40 2008 001 074

(51) **LOC (9) Cl.** **12-05**

(52) **U.S. Cl.** **D34/28**

(58) **Field of Classification Search** D34/28,
D34/33, 35, 36; 254/324, 143, 45, 2 C, 8 R,
254/10 R, 124; 212/294, 295, 901, 179,
212/94; 424/11; 182/152, 2

See application file for complete search history.

(56) **References Cited**

U.S. PATENT DOCUMENTS

2,436,337 A * 2/1948 Smith et al. 104/126
2,994,939 A * 8/1961 Matthews 28/208
4,295,777 A * 10/1981 Bell et al. 414/458
4,762,239 A * 8/1988 Wissman et al. 212/179

4,941,645 A * 7/1990 Hall 254/324
D328,512 S * 8/1992 Miller D34/28
5,184,914 A * 2/1993 Basta 405/3
5,358,217 A * 10/1994 Dach 254/2 R
5,505,578 A * 4/1996 Fuller 414/427
D378,457 S * 3/1997 Page D34/28
D576,375 S * 9/2008 Carnevali D34/28
D611,393 S * 3/2010 Liljedahl D12/128
2002/0175319 A1 * 11/2002 Green et al. 254/45
2008/0157041 A1 * 7/2008 Martin 254/2 R

* cited by examiner

Primary Examiner — Cynthia E Ramirez

(74) *Attorney, Agent, or Firm* — The Nath Law Group;
Jerald L. Meyer; Stanley N. Protigal

(57) **CLAIM**

The ornamental design for a lifting apparatus, as shown and described.

DESCRIPTION

FIG. 1 is a front view of the lifting apparatus;
FIG. 2 is a rear view of the lifting apparatus, showing the cable cut away for convenience of illustration;
FIG. 3 is a side connect view of the lifting apparatus;
FIG. 4 is a side connect view with a motor for the lifting apparatus; and,
FIG. 5 is a bottom view of the support footer for the lifting apparatus.

The elements shown in FIGS. 3, 4 and 5 are shown enlarged for clarity of illustration.

1 Claim, 5 Drawing Sheets

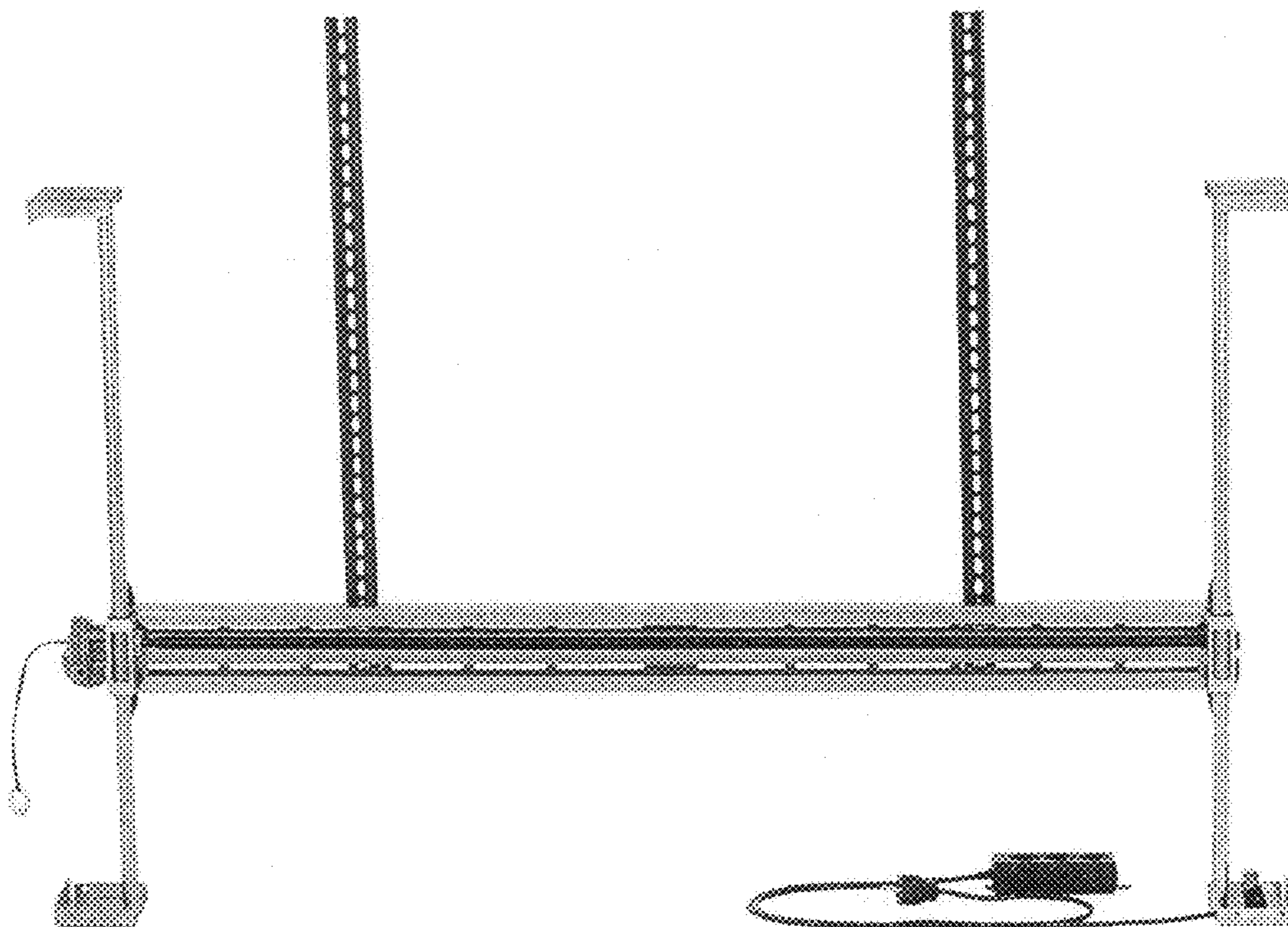

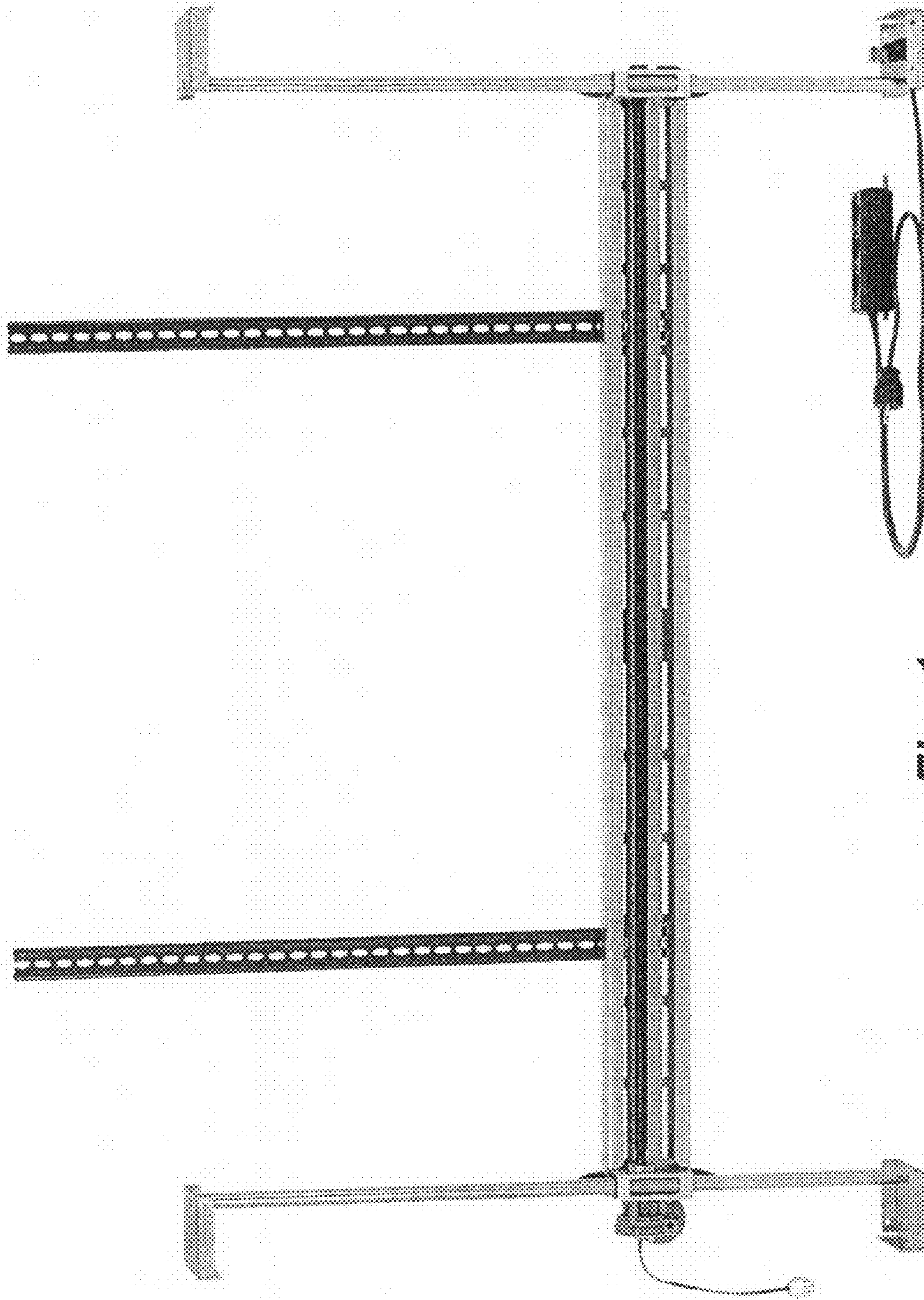

Fig. 1

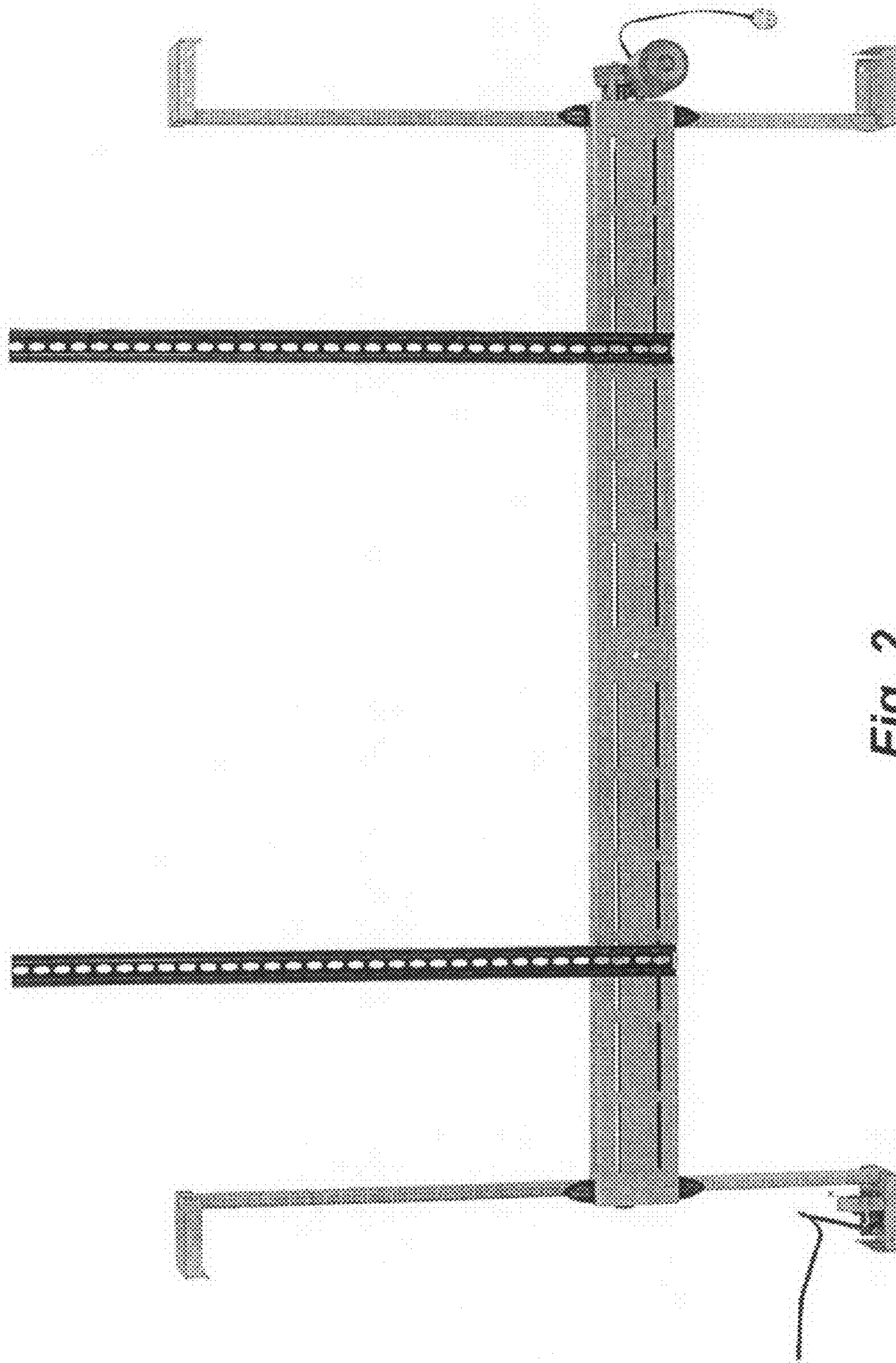

Fig. 2

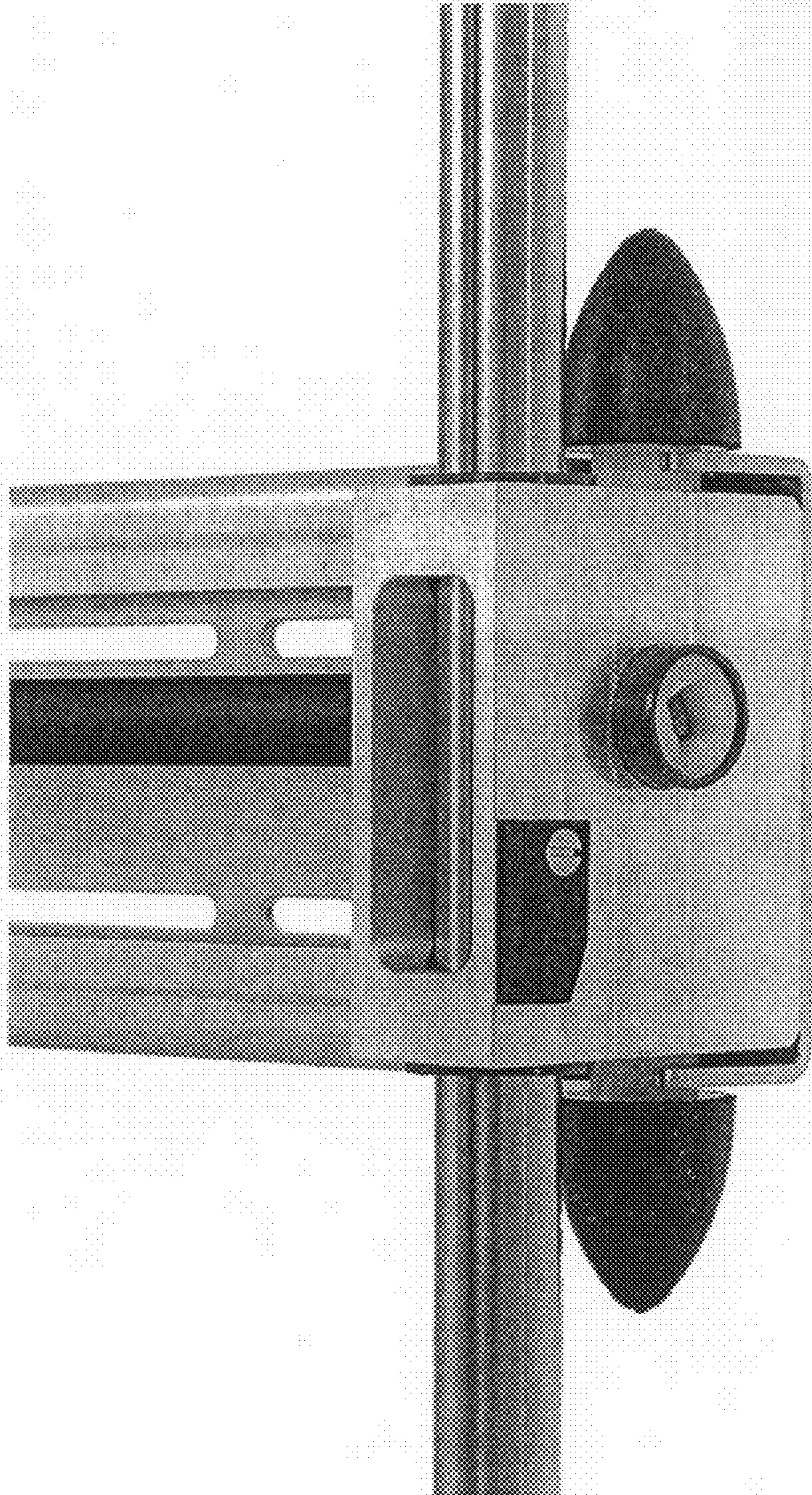

Fig. 3

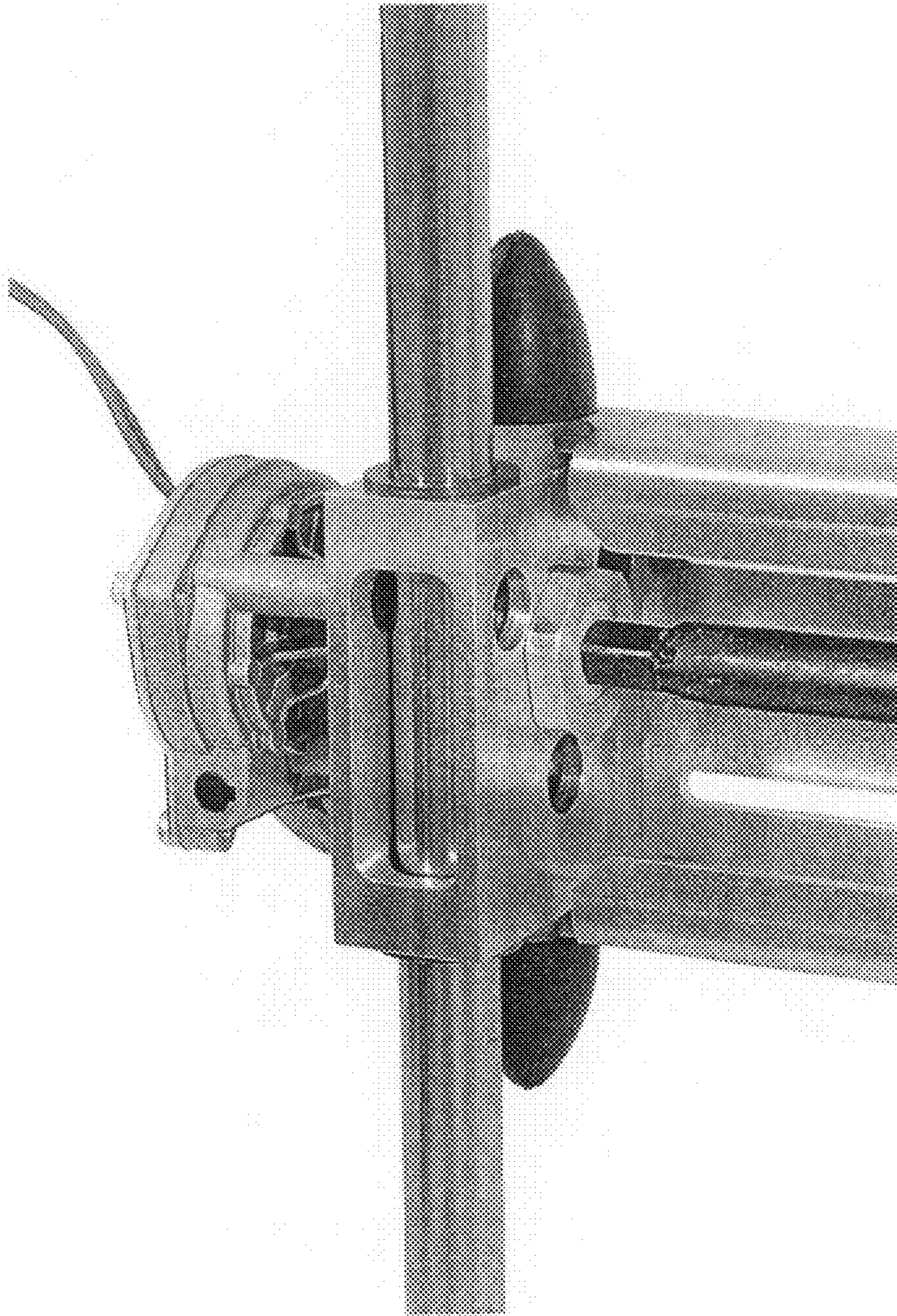

Fig. 4

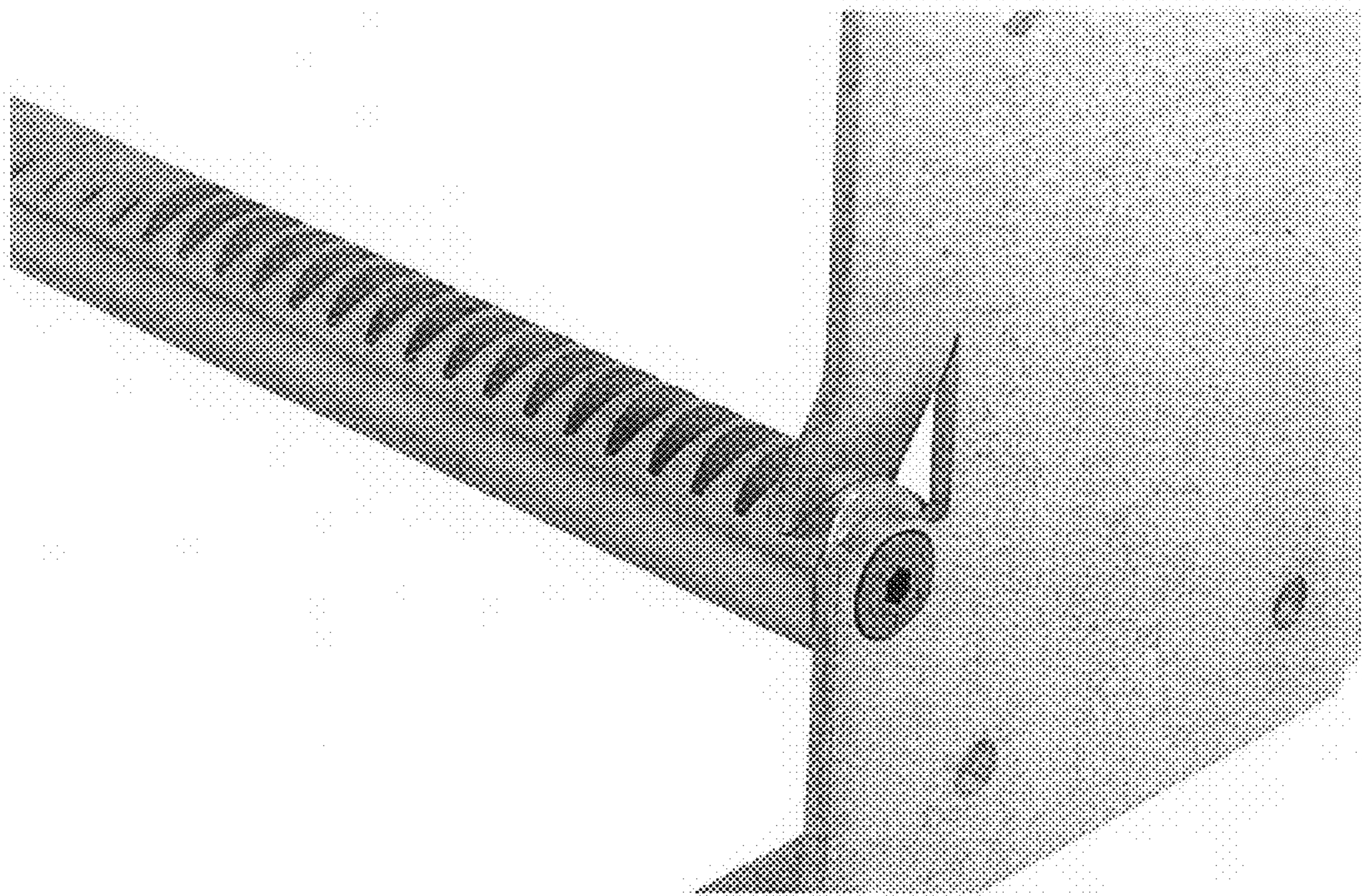

Fig. 5