



US00D636003S

(12) **United States Design Patent**  
**Linson et al.**

(10) **Patent No.:** **US D636,003 S**

(45) **Date of Patent:** **\*\* Apr. 12, 2011**

(54) **VEHICLE WHEEL TARGET MOUNT ASSEMBLY**

(75) Inventors: **Dennis M. Linson**, St. Charles, MO (US); **Michael T. Stieff**, Wentzville, MO (US)

(73) Assignee: **Hunter Engineering Company**, Bridgeton, MO (US)

(\*\*) Term: **14 Years**

(21) Appl. No.: **29/367,922**

(22) Filed: **Aug. 16, 2010**

(51) **LOC (9) Cl.** ..... **15-99**

(52) **U.S. Cl.** ..... **D15/199**

(58) **Field of Classification Search** ..... D12/202, D12/223; D15/199; 157/1.1, 1.17, 1.2, 1.22, 157/1.26, 1.43, 1.47, 1.48, 5, 14, 16, 17, 157/19, 20, 21

See application file for complete search history.

(56) **References Cited**

**U.S. PATENT DOCUMENTS**

D251,839	S *	5/1979	Bodde	.....	D12/202
5,941,294	A *	8/1999	Cunningham et al.	.....	157/1.24
7,373,964	B2 *	5/2008	Bishop	.....	157/1.17
7,438,110	B2 *	10/2008	Kim	.....	157/1.24
7,513,288	B2 *	4/2009	Corghi	.....	157/1.17
D598,939	S *	8/2009	Ortega	.....	D15/199
D614,679	S *	4/2010	Corghi	.....	D15/199
7,712,510	B2 *	5/2010	Zoller	.....	157/1.24
2002/0017368	A1 *	2/2002	Corghi	.....	157/1.24
2005/0006031	A1 *	1/2005	Pellerin et al.	.....	157/1.17
2005/0241776	A1 *	11/2005	Gonzaga	.....	157/1.17

2007/0074824	A1 *	4/2007	Lawson et al.	.....	157/1.24
2008/0128091	A1 *	6/2008	Nomura	.....	157/1.17
2008/0128092	A1 *	6/2008	Lehr et al.	.....	157/1.22
2008/0173408	A1 *	7/2008	Vignoli	.....	157/1.24
2008/0179014	A1 *	7/2008	Sotgiu	.....	157/1.3
2009/0101287	A1 *	4/2009	Gonzaga et al.	.....	157/1.17
2009/0266494	A1 *	10/2009	Sotgiu	.....	157/1.24
2010/0065224	A1 *	3/2010	Ferrari et al.	.....	157/1.17
2010/0089538	A1 *	4/2010	Bonacini	.....	157/1.22
2010/0163189	A1 *	7/2010	Lawson et al.	.....	157/1.22

\* cited by examiner

*Primary Examiner* — Patricia Palasik

(74) *Attorney, Agent, or Firm* — Polster, Lieder, Woodruff & Lucchesi, L.C.

(57) **CLAIM**

The ornamental design for a vehicle wheel target mount assembly, as shown and described.

**DESCRIPTION**

FIG. 1 is a perspective upper front-left view of the vehicle wheel target mount assembly of the present invention; FIG. 2 is a perspective lower front-right view of the embodiment shown in FIG. 1; FIG. 3 is a perspective back view of the embodiment shown in FIG. 1; FIG. 4 is a left side perspective view of the embodiment shown in FIG. 1; FIG. 5 is a bottom plan view of the embodiment shown in FIG. 1; FIG. 6 is a front elevation view of the embodiment shown in FIG. 1; and, FIG. 7 is a back elevation view of the embodiment shown in FIG. 1.

**1 Claim, 7 Drawing Sheets**

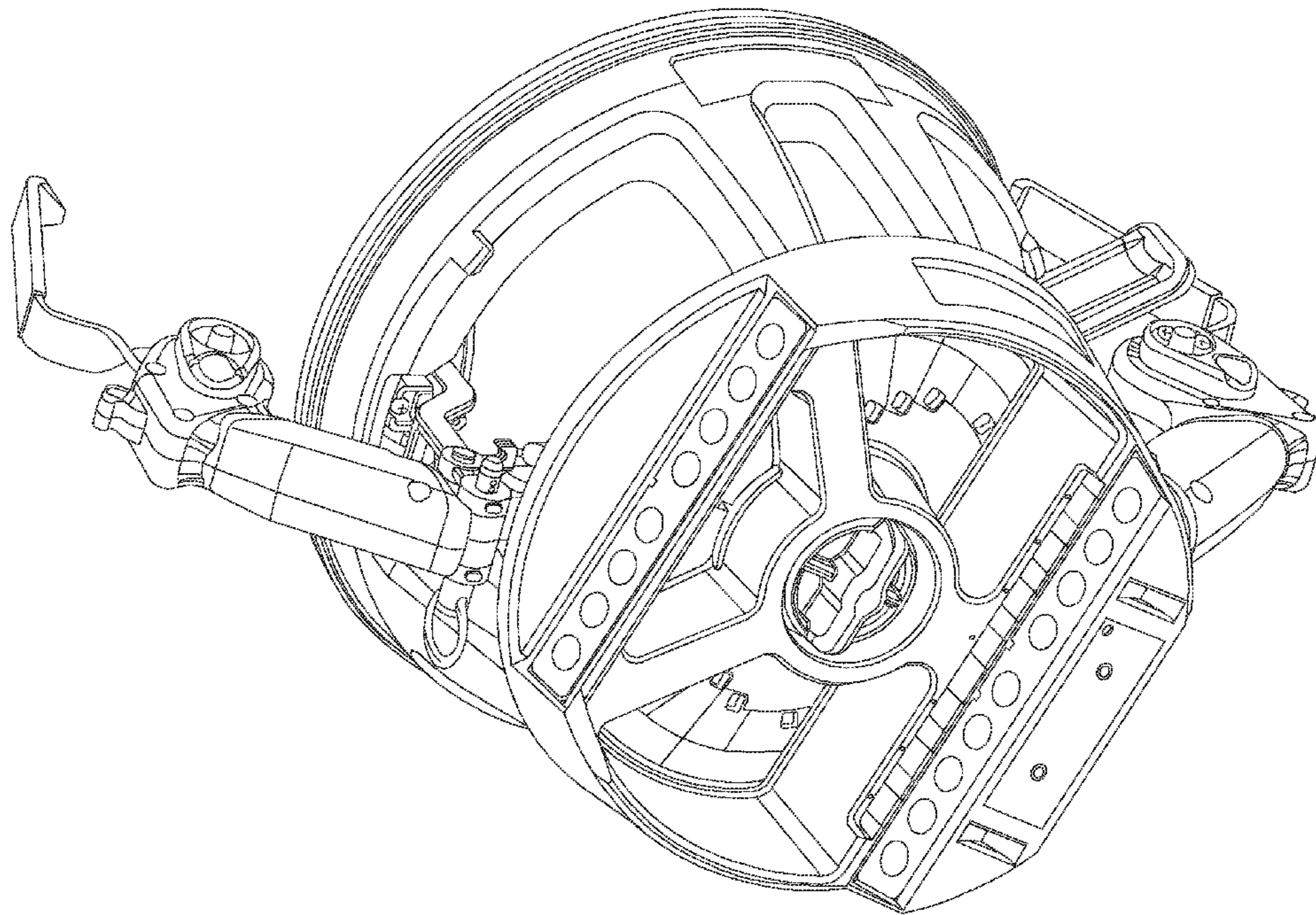



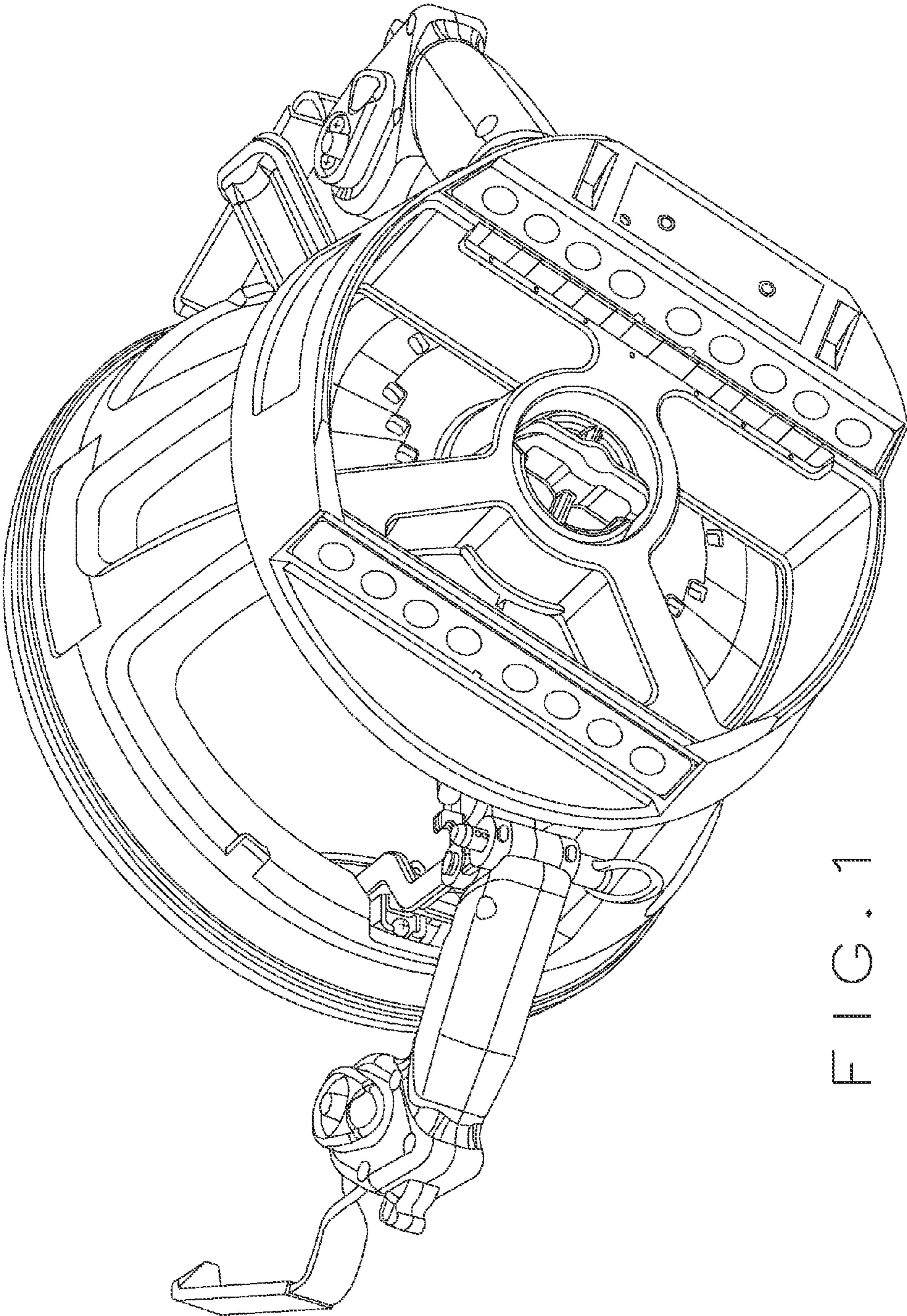

FIG. 1

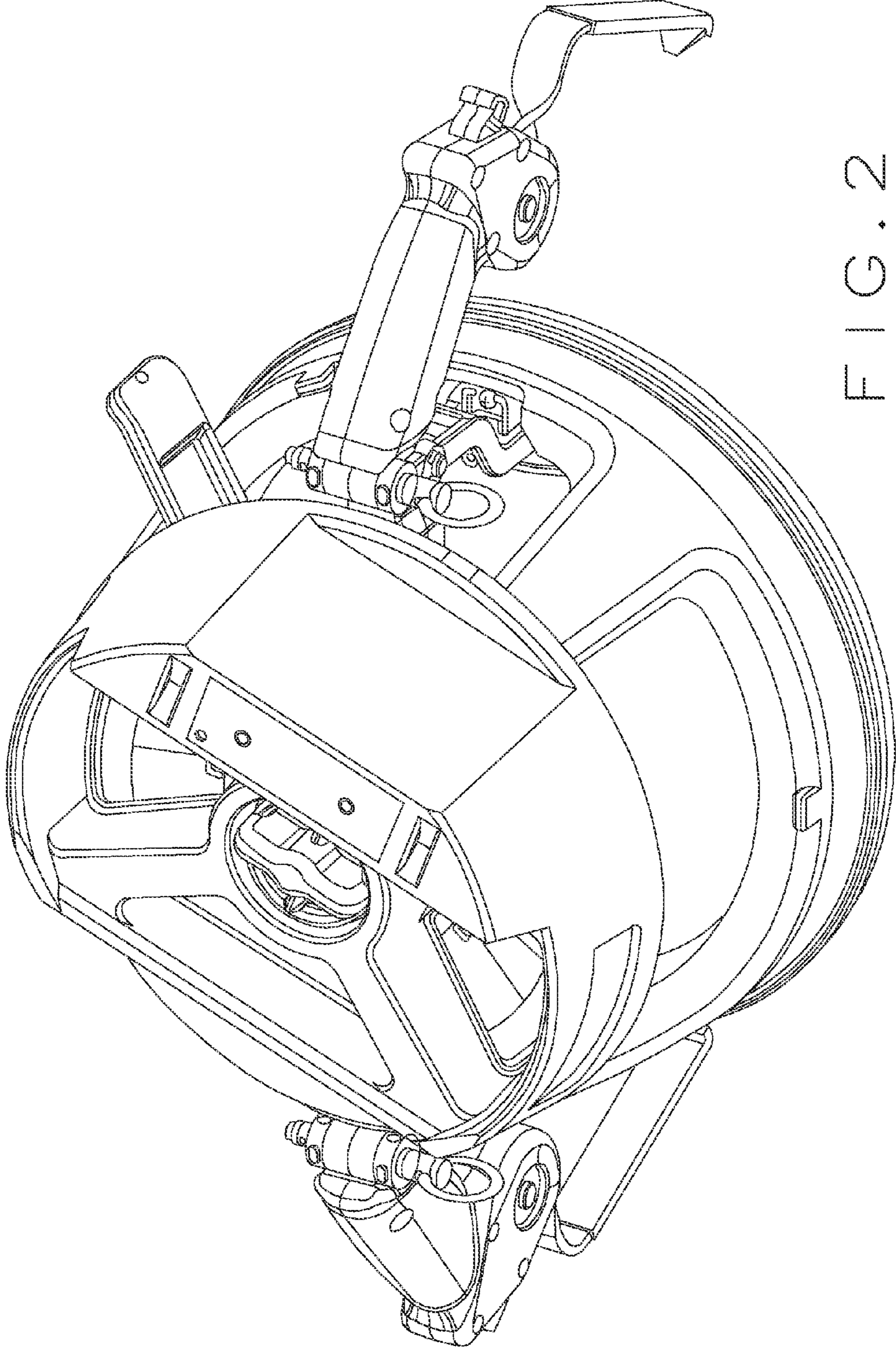

FIG. 2



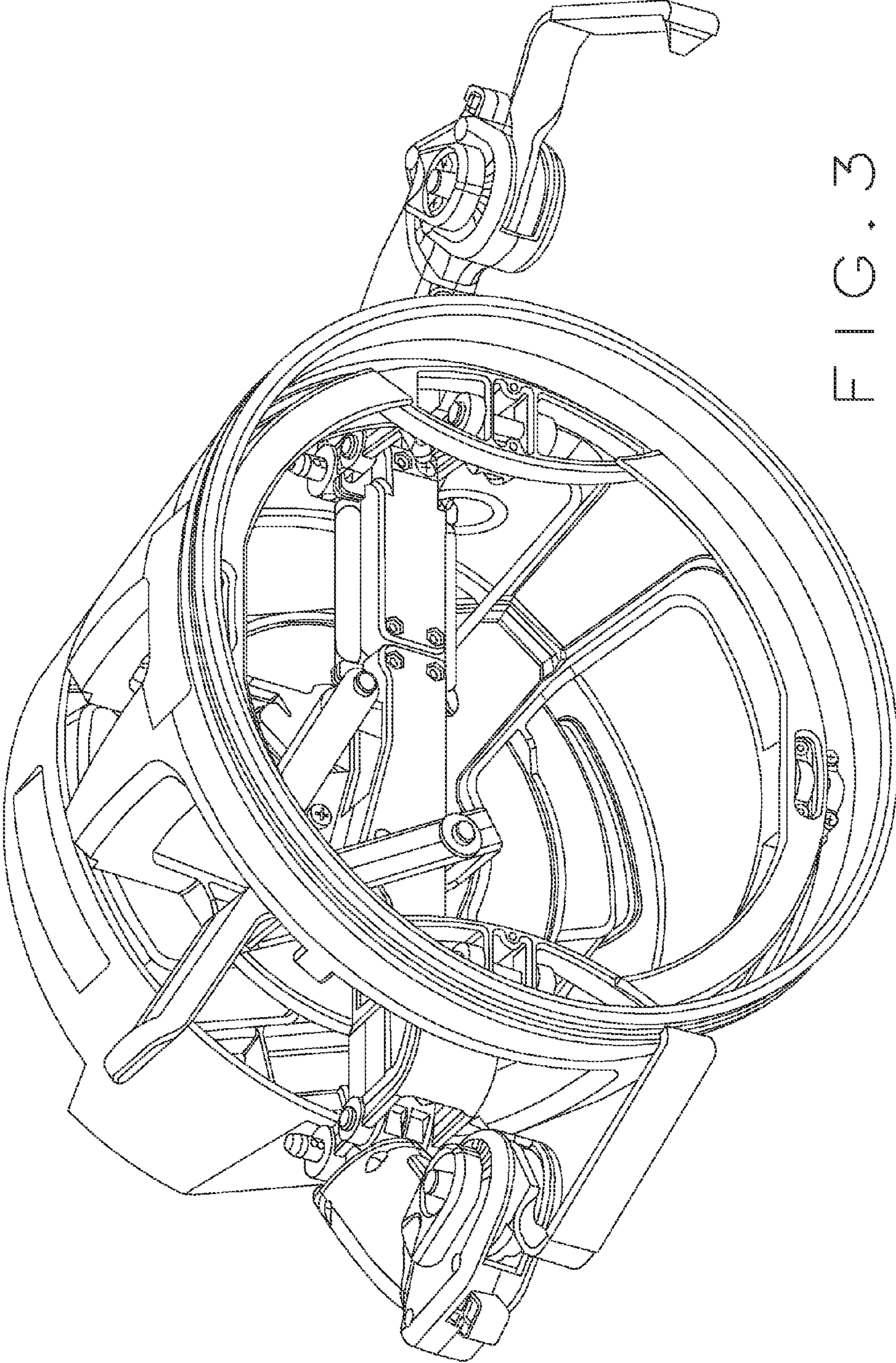

FIG. 3

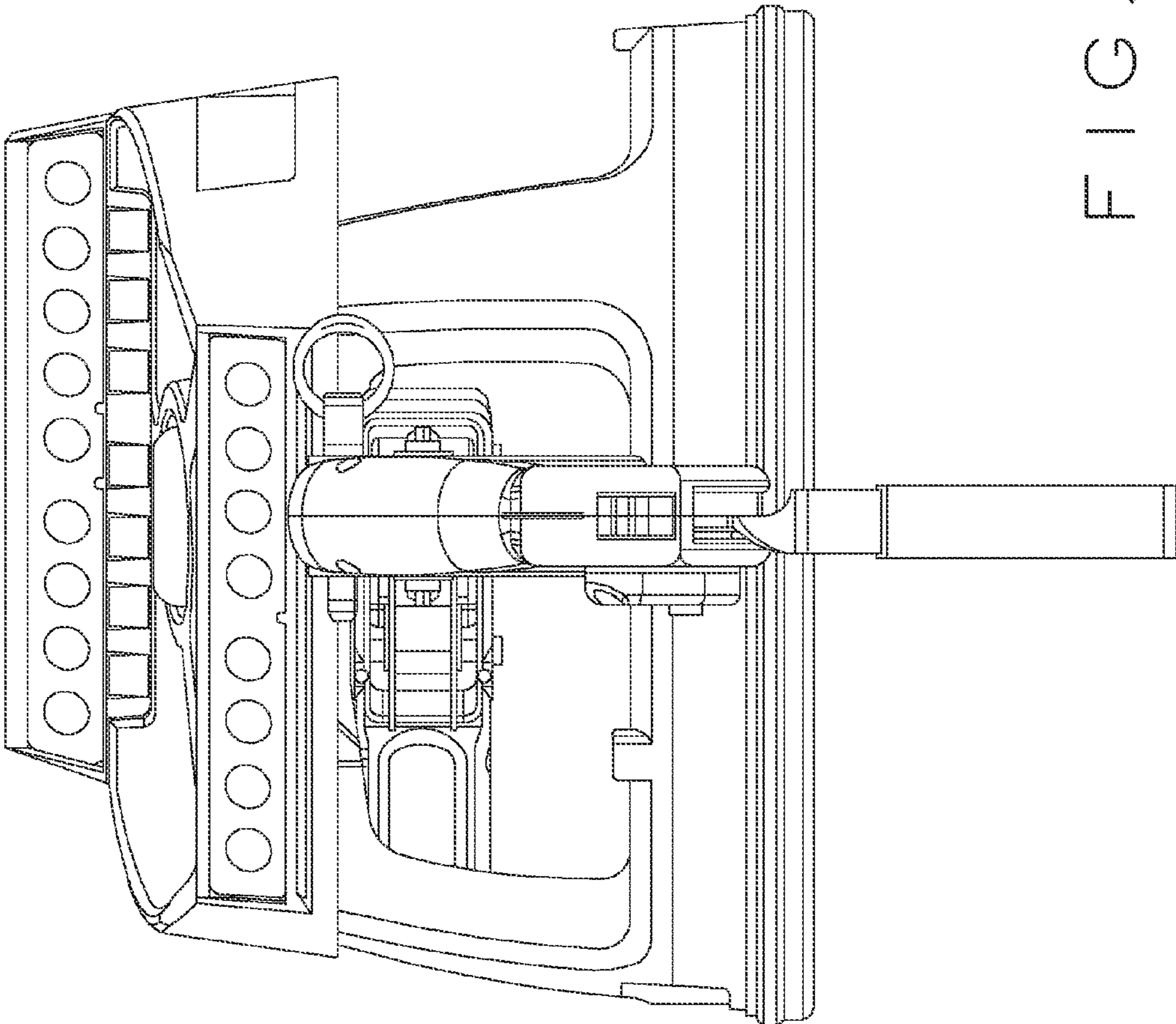

FIG. 4

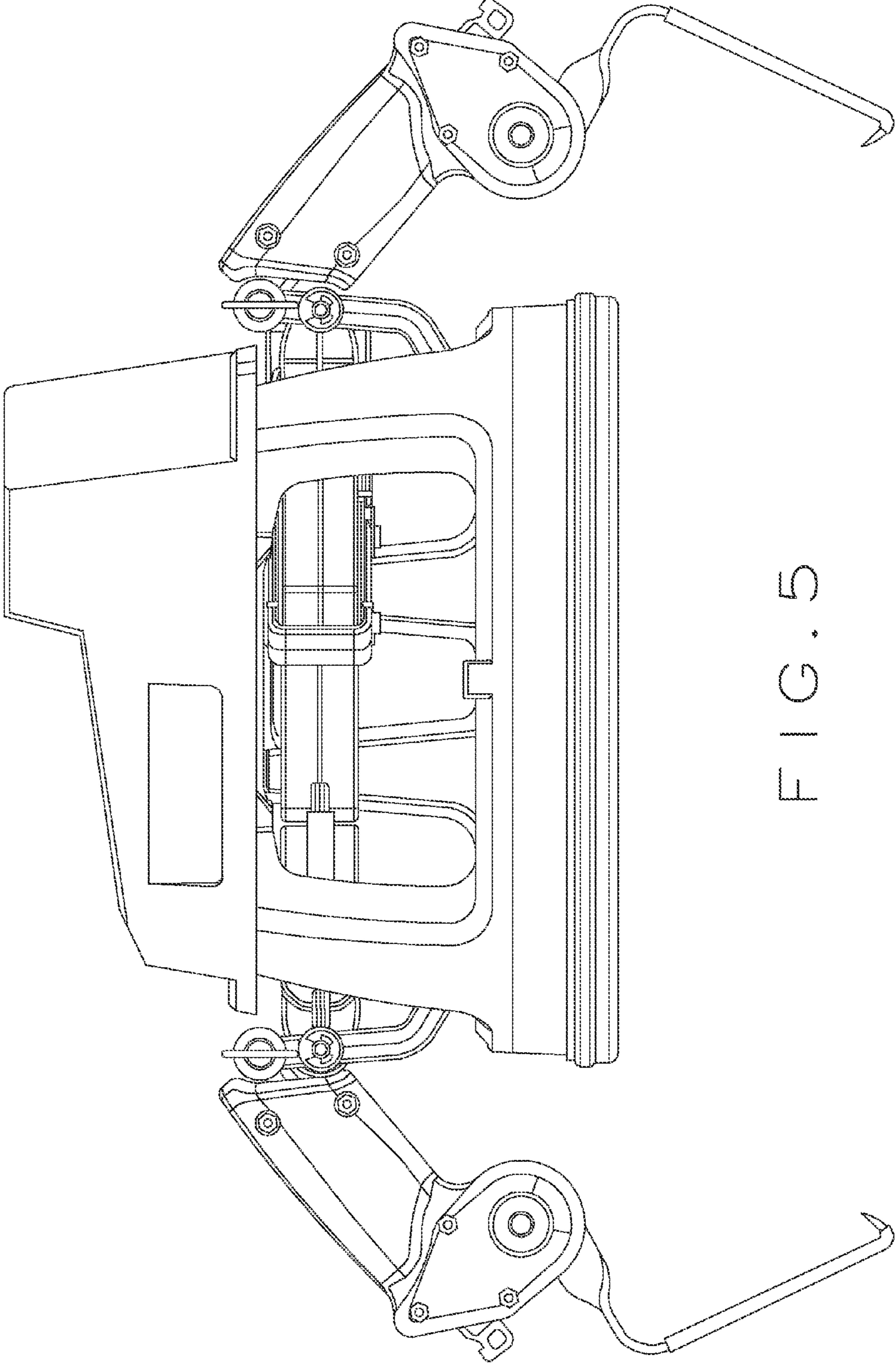

FIG. 5



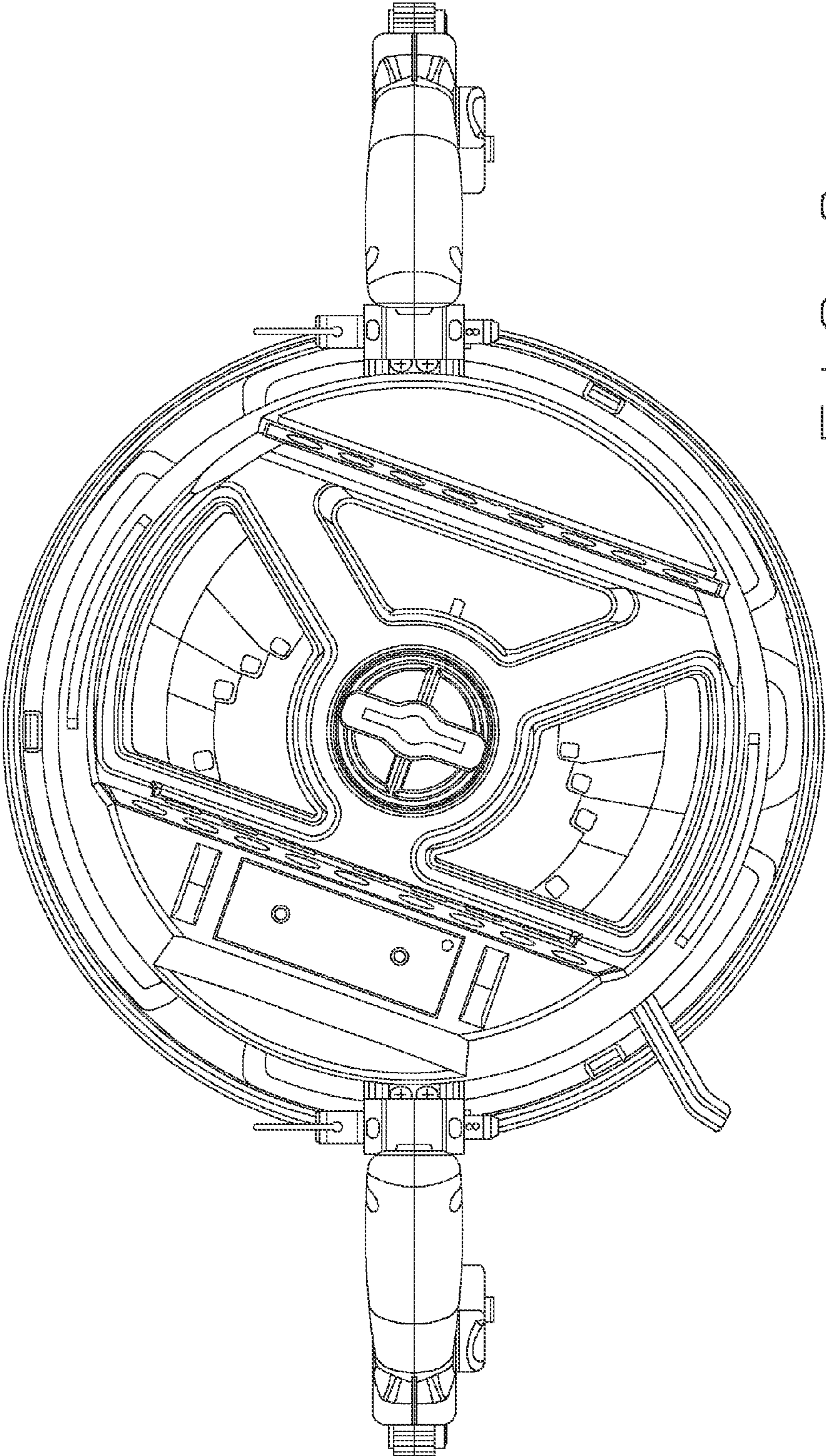

FIG. 6

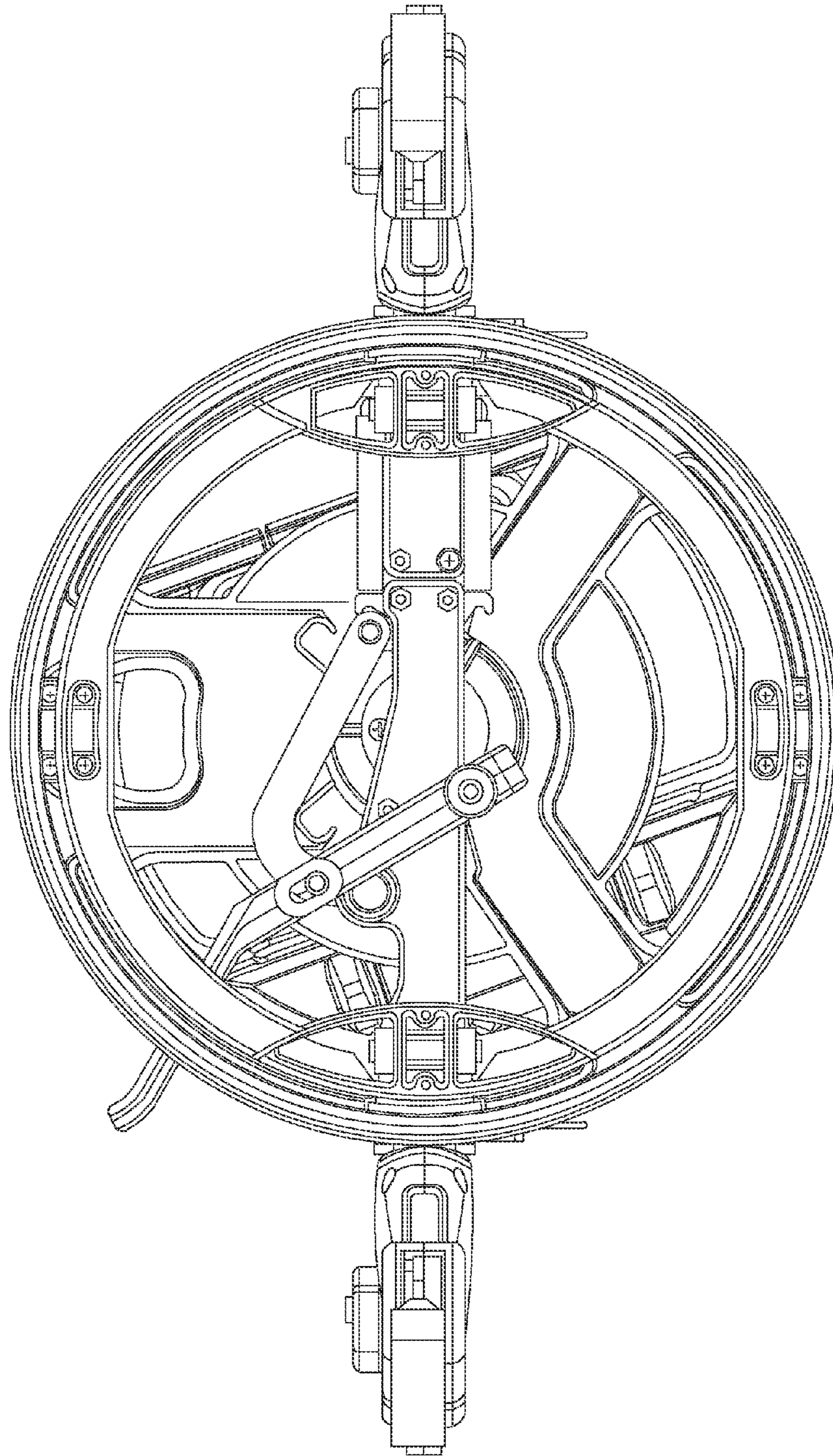

FIG. 7