



US00D635789S

(12) **United States Design Patent**
Rechberg et al.

(10) **Patent No.:** **US D635,789 S**

(45) **Date of Patent:** **** *Apr. 12, 2011**

(54) **DRAWER SLIDE AUTO-CLOSE DAMPENING MECHANISM**

(75) Inventors: **Frank H. Rechberg**, Corona, CA (US);
Jason A. Rechberg, Anaheim, CA (US)

(73) Assignee: **Actron Manufacturing, Inc.**, Corona, CA (US)

(*) Notice: This patent is subject to a terminal disclaimer.

(**) Term: **14 Years**

(21) Appl. No.: **29/345,965**

(22) Filed: **Oct. 23, 2009**

(51) **LOC (9) Cl.** **08-05**

(52) **U.S. Cl.** **D6/377**

(58) **Field of Classification Search** D8/377;
312/334.44, 334, 46, 334.9, 333; 384/18
See application file for complete search history.

(56) **References Cited**

U.S. PATENT DOCUMENTS

1,557,765	A	10/1925	Nicholas	
1,910,208	A	5/1933	Gronberg et al.	
2,547,513	A	4/1951	Wikman	
2,752,219	A	6/1956	Yonkers	
3,074,766	A	1/1963	Meyer	
3,259,447	A	7/1966	Deutsch	
3,401,998	A	9/1968	Evans et al.	
3,773,395	A	11/1973	Antonaccio	
3,801,166	A	4/1974	York	
3,937,531	A	2/1976	Hagen et al.	
4,067,632	A *	1/1978	Sekerich	312/334.9
4,423,914	A	1/1984	Vanderley	
4,441,772	A	4/1984	Fielding et al.	
4,469,384	A	9/1984	Fler et al.	
4,537,450	A	8/1985	Baxter	
4,749,242	A	6/1988	Rechberg	
4,932,792	A	6/1990	Baxter	
4,988,214	A	1/1991	Clement	

6,126,255	A	10/2000	Yang	
6,244,678	B1	6/2001	Dopp et al.	
6,435,636	B1	8/2002	MacMillan	
6,705,689	B2 *	3/2004	Chen et al.	312/334.46
6,824,233	B2 *	11/2004	Chen et al.	312/334.46
6,860,575	B2 *	3/2005	Chen et al.	312/334.46
7,008,030	B2 *	3/2006	Yang	312/334.46
7,090,319	B2 *	8/2006	Milligan et al.	312/334.46
D535,551	S *	1/2007	Milligan	D8/377
7,404,611	B1 *	7/2008	Que	312/334.46
7,537,296	B2	5/2009	Leon et al.	
2008/0218046	A1	9/2008	Rechberg	

OTHER PUBLICATIONS

Admitted Prior Art: Photographs (2) showing a Carrier and Piston manufactured by RD Hardware.

* cited by examiner

Primary Examiner — Holly H Baynham

(74) *Attorney, Agent, or Firm* — Stetina Brunda Garred & Brucker

(57) **CLAIM**

The ornamental design for a drawer slide auto-close dampening mechanism, as shown and described.

DESCRIPTION

FIG. 1 is a front perspective view of the drawer slide auto-close dampening mechanism of the present invention showing our new design with the dotted lines depicting solely environmental structure and forming no part of the claimed design;

FIG. 2 is a rear perspective view thereof;

FIG. 3 is a top plan view thereof;

FIG. 4 is a left end view thereof;

FIG. 5 is a side elevational view thereof;

FIG. 6 is a front end view thereof;

FIG. 7 is a bottom plan view thereof; and,

FIG. 8 is a rear elevational view thereof.

1 Claim, 4 Drawing Sheets

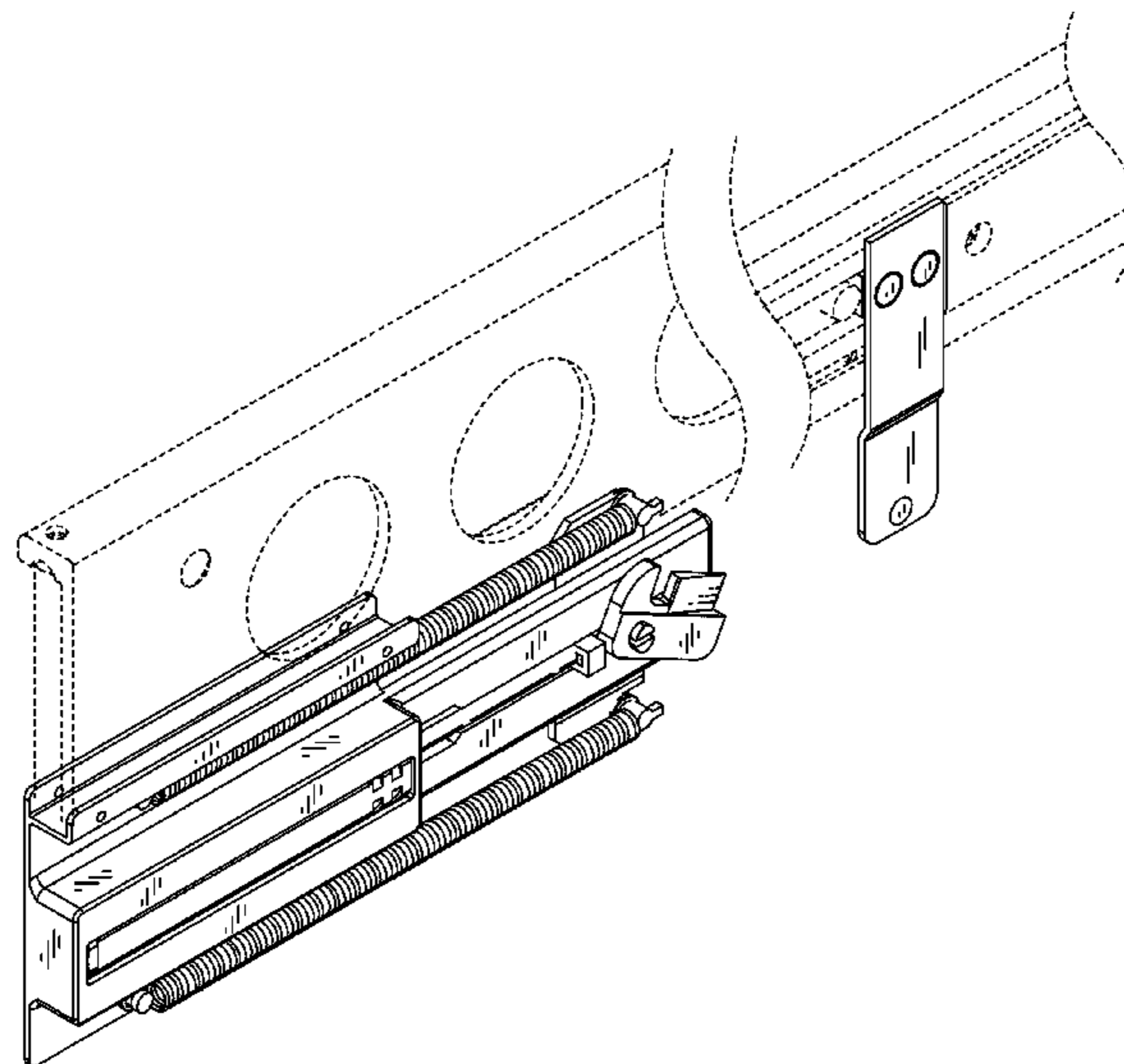

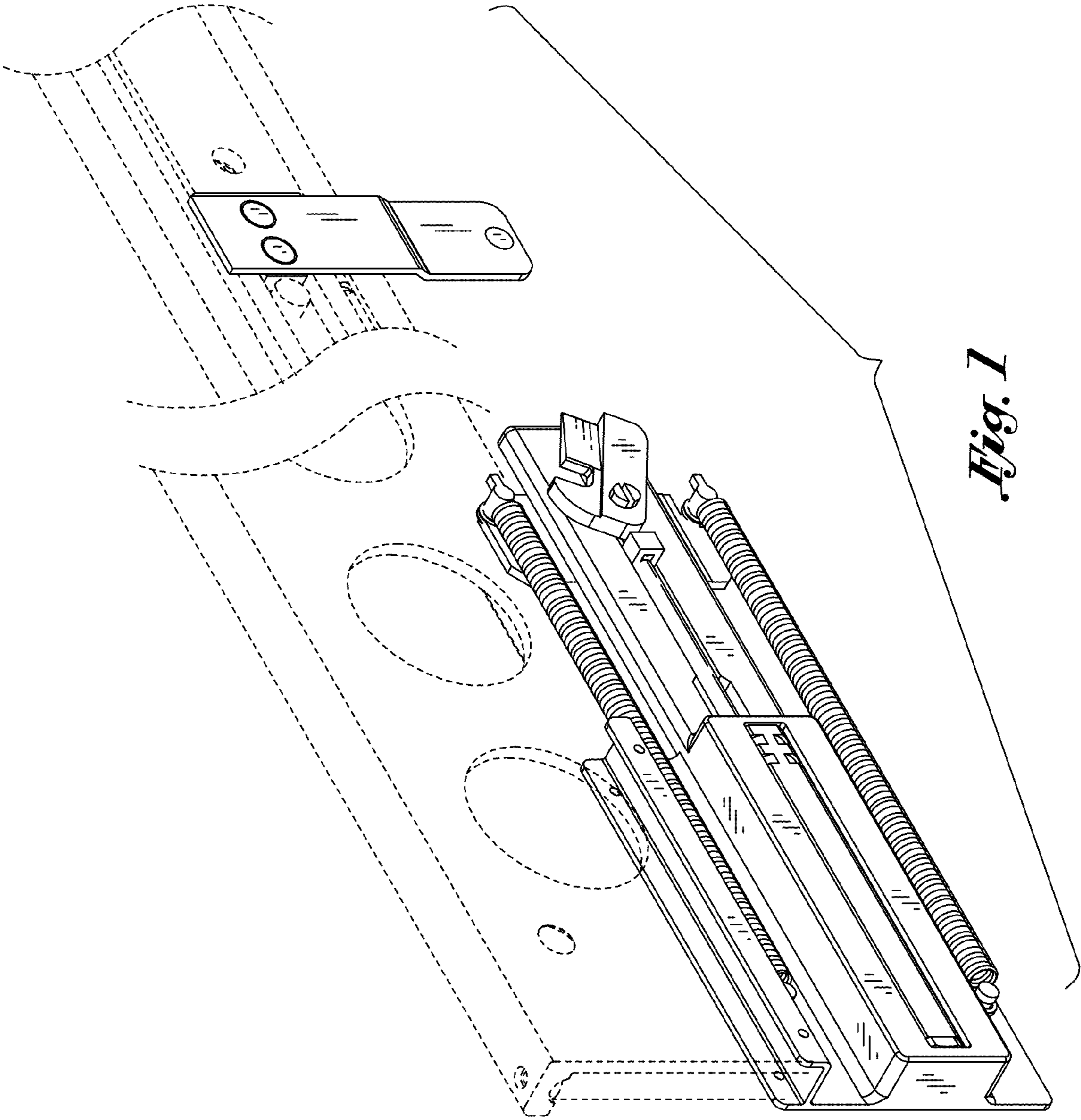
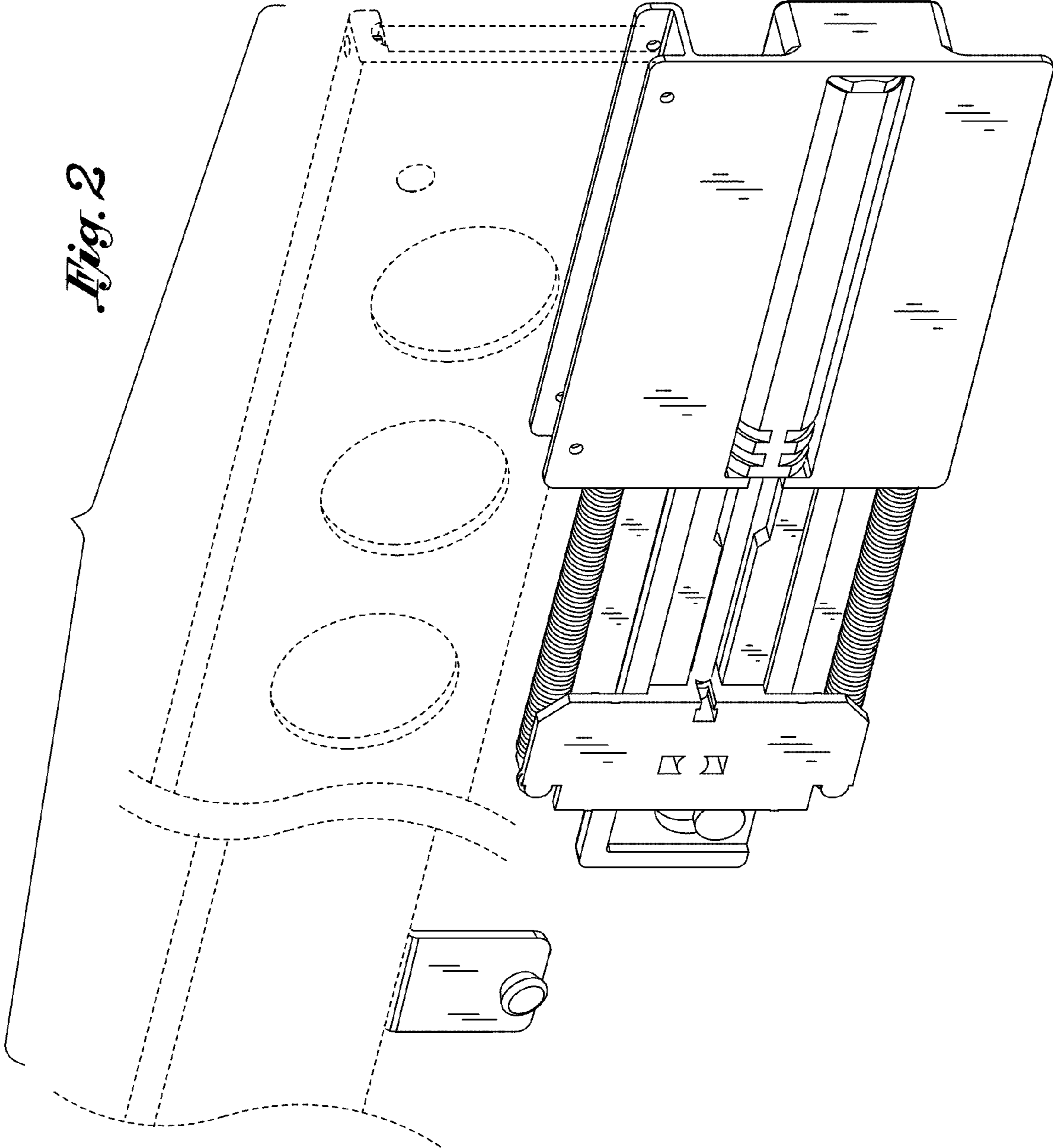

Fig. 1



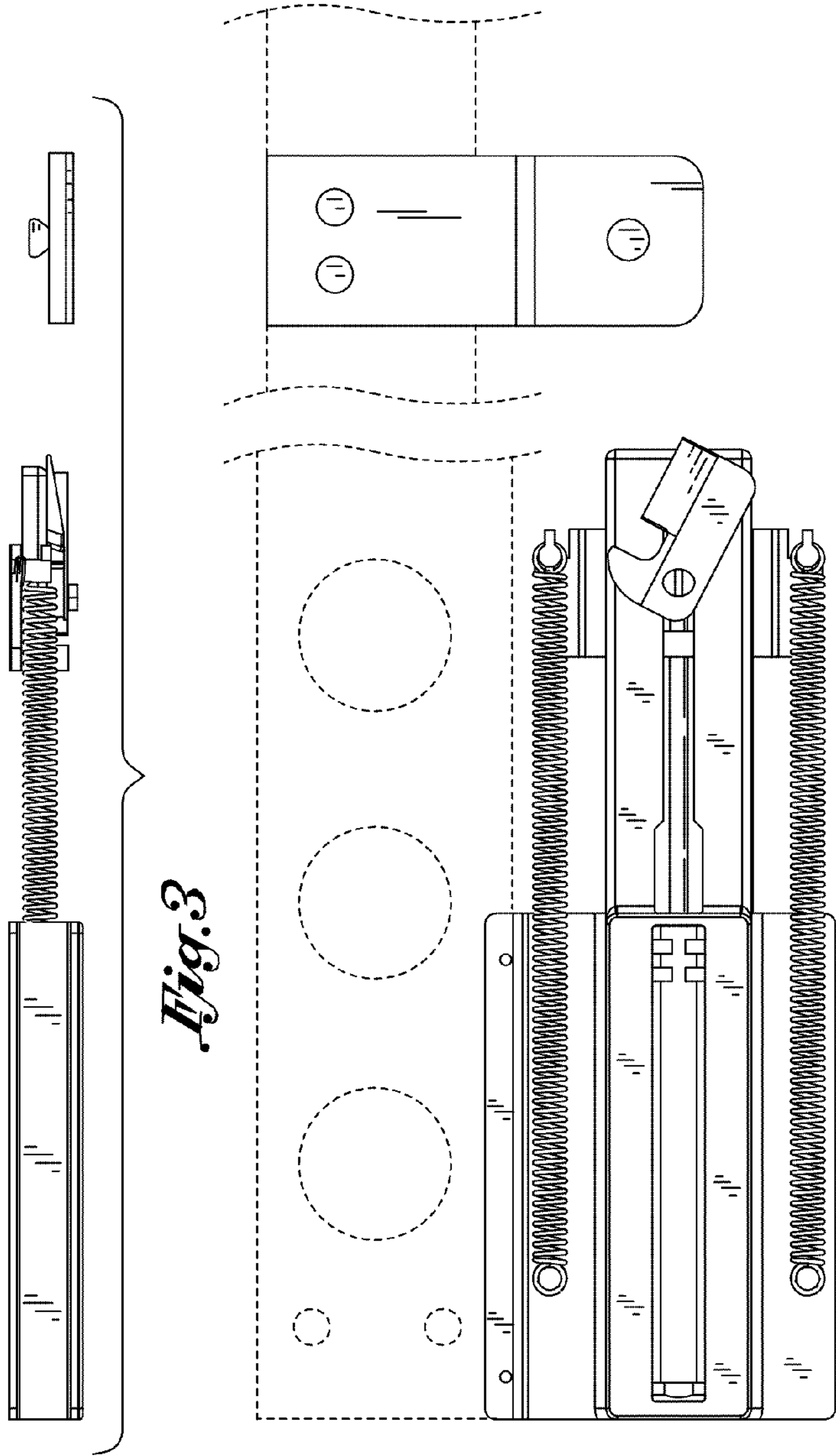

Fig. 3

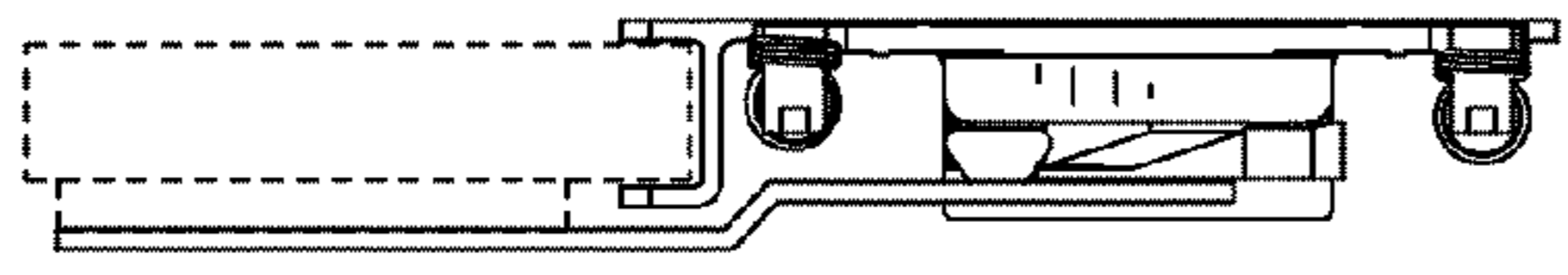

Fig. 4

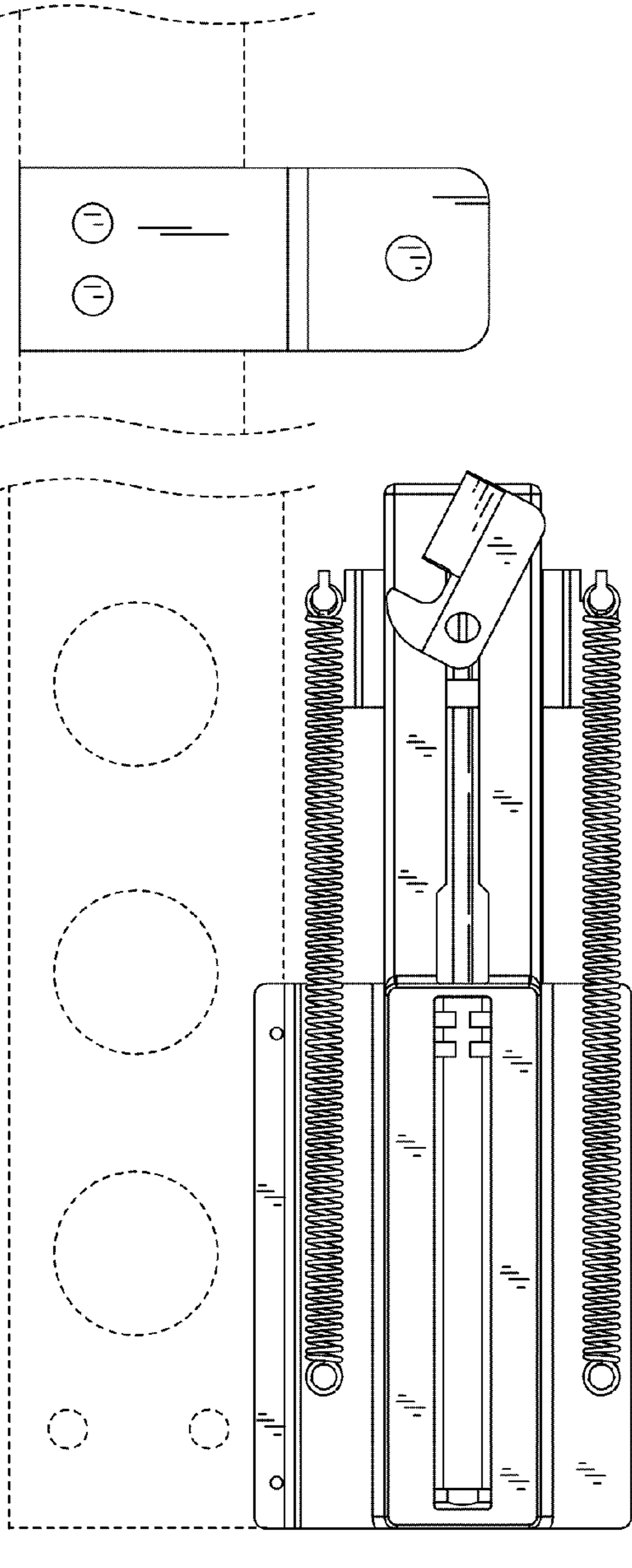

Fig. 5

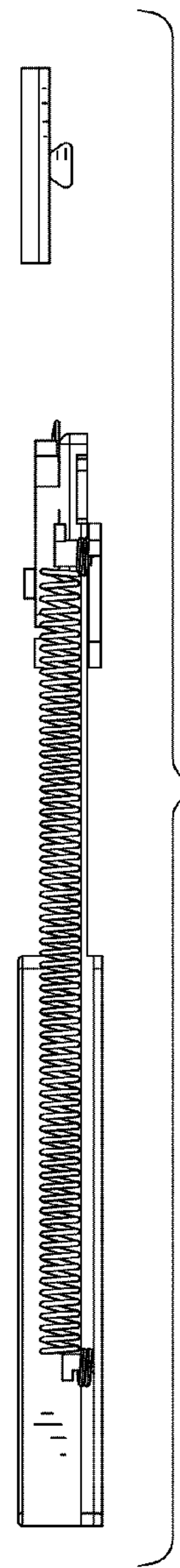

Fig. 6

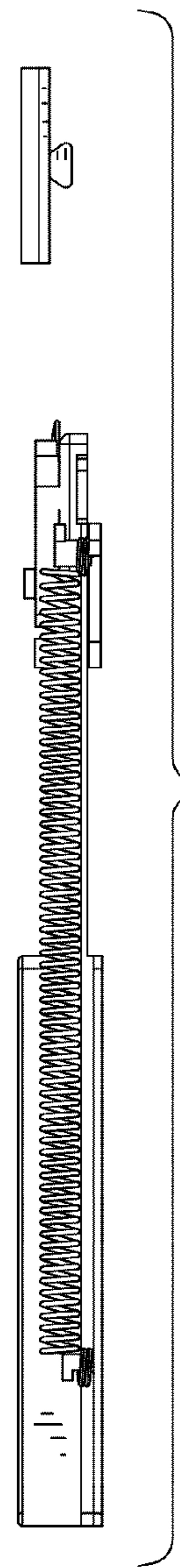

Fig. 7

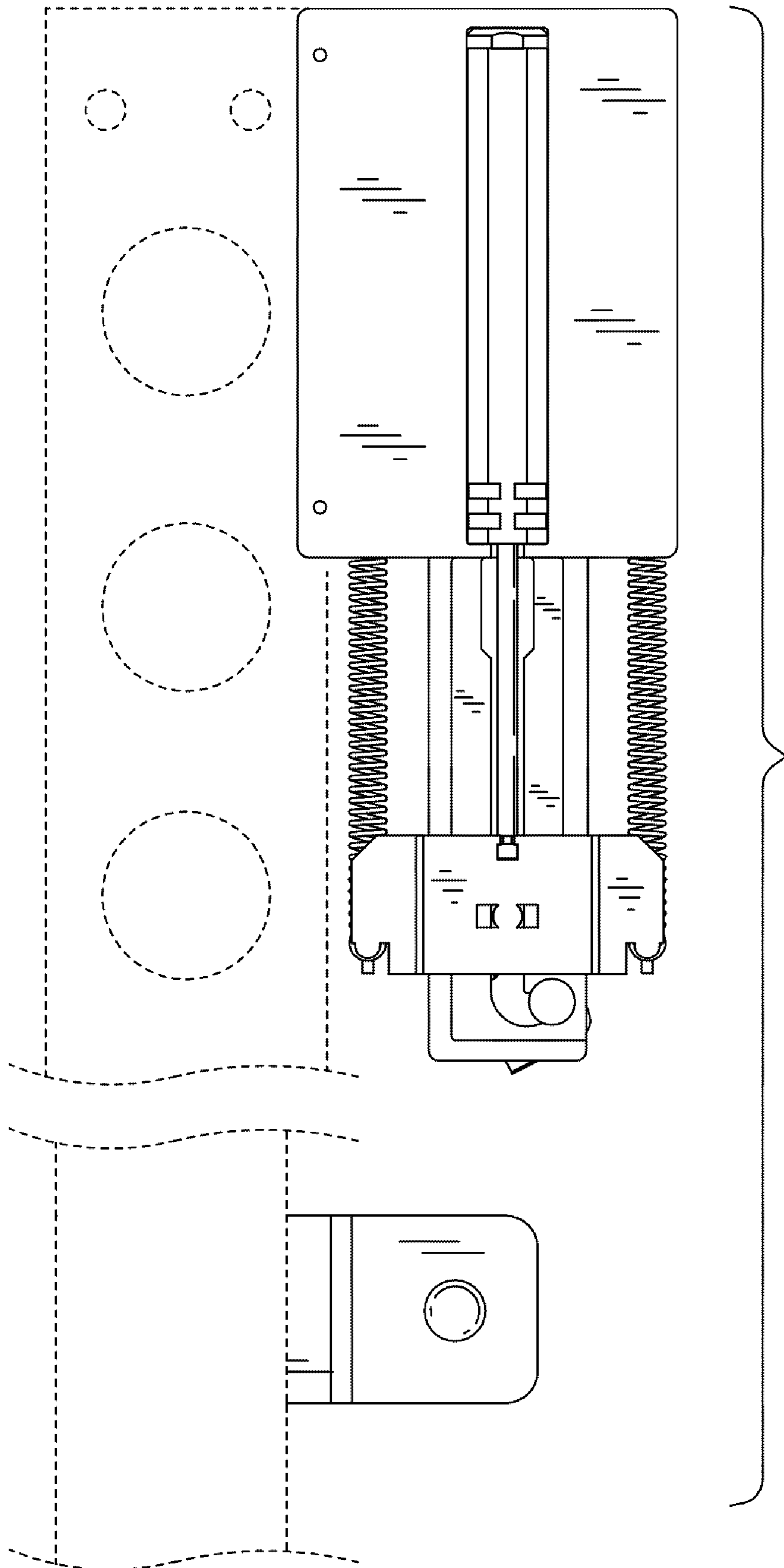

Fig. 8