



US00D635664S

(12) **United States Design Patent**  
**Beck**

(10) **Patent No.:** **US D635,664 S**

(45) **Date of Patent:** **\*\* Apr. 5, 2011**

(54) **IN-LINE OCCLUDER**

(75) Inventor: **Kent Beck**, Layton, UT (US)

(73) Assignee: **Zevex, Inc.**, Salt Lake City, UT (US)

(\*\*) Term: **14 Years**

(21) Appl. No.: **29/214,043**

(22) Filed: **Sep. 27, 2004**

**Related U.S. Application Data**

(62) Division of application No. 29/167,141, filed on Sep. 9, 2002, now Pat. No. Des. 503,978.

(51) **LOC (9) Cl.** ..... **24-02**

(52) **U.S. Cl.** ..... **D24/129**

(58) **Field of Classification Search** ..... D24/129-130,  
D24/111-112; 604/905, 256, 411, 412, 246,  
604/118, 67; 439/598

See application file for complete search history.

(56) **References Cited**

**U.S. PATENT DOCUMENTS**

2,471,623	A	5/1949	Hubbell
2,518,165	A	8/1950	Millard
2,858,095	A	10/1958	Harris et al.
2,999,499	A	9/1961	Willet
3,213,882	A	10/1965	Beatty
3,329,391	A	7/1967	Deane
3,985,140	A	10/1976	Harris
3,998,364	A	12/1976	Hollander
4,037,596	A	7/1977	LeFevre et al.
4,063,555	A	12/1977	Ulinder
4,065,093	A	12/1977	Phillips
4,106,675	A	8/1978	Taylor
4,142,645	A	3/1979	Walton
4,230,151	A	10/1980	Jonsson
4,236,880	A	12/1980	Archibald
4,381,591	A	5/1983	Barger et al.
4,382,453	A	5/1983	Bujan et al.
4,425,116	A	1/1984	Bilstad et al.

D272,850	S	*	2/1984	Kulle	.....	D24/112
4,453,295	A		6/1984	Laszczower		
4,498,843	A		2/1985	Schneider et al.		
4,524,802	A		6/1985	Lawrence et al.		
4,527,588	A		7/1985	Tseo et al.		
4,559,045	A		12/1985	Danby et al.		
4,579,553	A		4/1986	Urquhart et al.		
4,596,557	A		6/1986	Pexa		
4,624,663	A		11/1986	Danby et al.		

(Continued)

**FOREIGN PATENT DOCUMENTS**

EP 0 150 666 A1 9/1984

(Continued)

*Primary Examiner* — T. Chase Nelson

*Assistant Examiner* — Eric L Goodman

(74) *Attorney, Agent, or Firm* — Bateman IP Law Group

(57) **CLAIM**

The ornamental design for an in-line occluder, as shown and described.

**DESCRIPTION**

FIG. 1 shows a right side view of an in-line occlude made in accordance with the design of the present invention, the left side view being a mirror image thereof;

FIG. 2 shows a top view of the in-line occluder of FIG. 1 made in accordance with the present invention, the bottom view being a mirror image thereof;

FIG. 3 shows a front end view of the in-line occluder of FIG. 1 made in accordance with the present invention;

FIG. 4 shows a rear end view of the in-line occluder of FIG. 1; and,

FIG. 5 shows a perspective view of the in-line occluder of FIG. 1.

The broken line showing is included for the purpose of illustrating portions of the article that form no part of the claimed design.

**1 Claim, 2 Drawing Sheets**

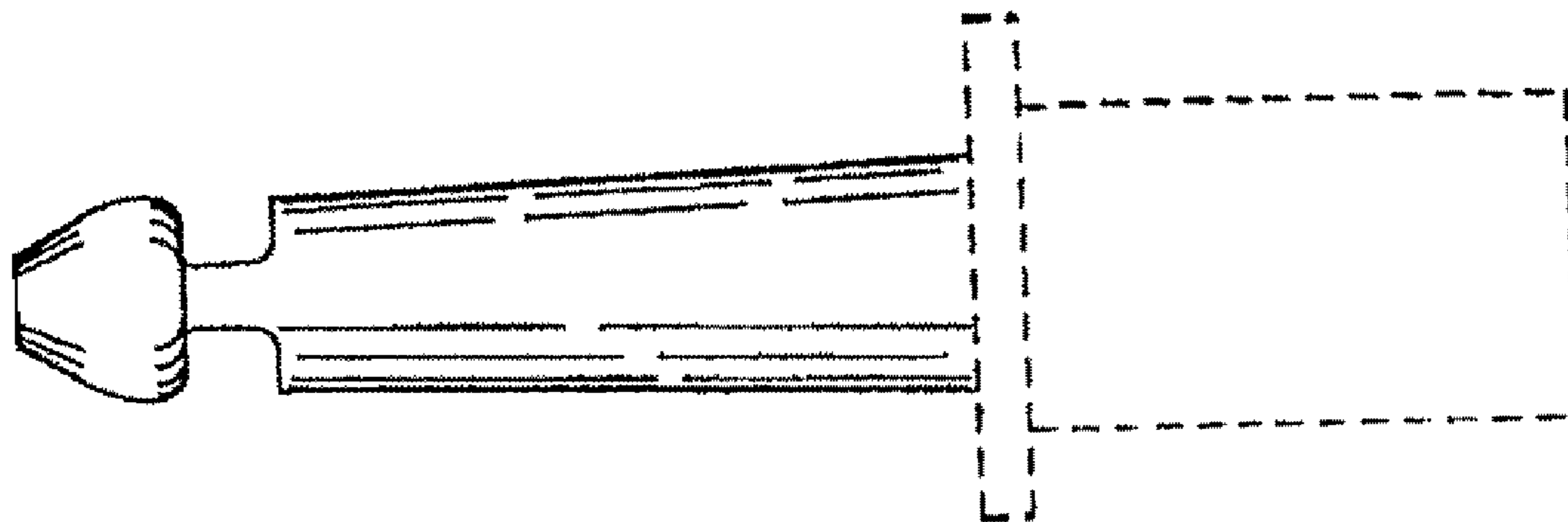

# US D635,664 S

Page 2

## U.S. PATENT DOCUMENTS

4,634,092	A	1/1987	Daniell et al.
4,645,489	A	2/1987	Krumme et al.
4,689,043	A	8/1987	Bisha
4,728,324	A	3/1988	Steigerwald et al.
4,730,635	A	3/1988	Linden
4,913,401	A	4/1990	Handke
4,935,010	A	6/1990	Cox et al.
4,950,245	A	8/1990	Brown et al.
4,960,259	A	10/1990	Sunnanvader et al.
5,020,562	A	6/1991	Richmond et al.
5,022,422	A	6/1991	di Palma
D319,312	S	8/1991	Schneider
5,083,561	A	1/1992	Russo
5,098,406	A	3/1992	Sawyer
5,151,019	A	9/1992	Danby et al.
5,219,327	A	6/1993	Okada
5,232,193	A	8/1993	Skakoon
5,238,218	A	8/1993	Mackal
5,257,978	A	11/1993	Haber et al.
5,265,847	A	11/1993	Vorhis
5,336,174	A	8/1994	Daoud et al.
5,395,351	A	3/1995	Munsch
5,396,925	A	3/1995	Poli
D357,312	S	4/1995	Riquier et al.
5,474,544	A	12/1995	Lynn
5,482,446	A	1/1996	Williamson et al.
5,531,713	A	7/1996	Mastronardi et al.
D374,718	S	10/1996	Dodge et al.
5,578,070	A	11/1996	Utterberg
5,704,584	A	1/1998	Winterer et al.
5,807,312	A	9/1998	Dzwonkiewicz

5,810,323	A	9/1998	Winterer et al.
5,826,621	A	10/1998	Jemmott
6,017,332	A	1/2000	Urrutia
6,092,695	A	7/2000	Loeffler
6,183,447	B1	2/2001	Urrutia
6,196,992	B1	3/2001	Keilman et al.
6,209,538	B1	4/2001	Casper et al.
D455,489	S	4/2002	Beck et al.
6,398,758	B1	6/2002	Jacobsen et al.
6,398,780	B1	6/2002	Farley et al.
6,461,335	B1	10/2002	Noecker
6,595,950	B1	7/2003	Miles et al.
6,623,447	B2	9/2003	Miles et al.
6,659,976	B2	12/2003	Beck et al.
D503,799	S *	4/2005	Beck ..... D24/129
D503,978	S *	4/2005	Beck ..... D24/129
2003/0125674	A1 *	7/2003	Cise et al. .... 604/247
2004/0220542	A1 *	11/2004	Cise et al. .... 604/500
2004/0225274	A1 *	11/2004	Jansen et al. .... 604/411
2004/0238776	A1 *	12/2004	Peters et al. .... 251/149.1
2005/0004520	A1 *	1/2005	Lemoine et al. .... 604/118
2005/0043703	A1 *	2/2005	Nordgren ..... 604/500
2006/0058740	A1 *	3/2006	Cise et al. .... 604/247
2010/0082001	A1 *	4/2010	Beck et al. .... 604/250

## FOREIGN PATENT DOCUMENTS

EP	00150666	A1	9/1984
EP	0 423 978	A2	10/1990
EP	0 423 978	A2	4/1991
EP	0 483 794	A1	10/1991
EP	0 483 794	A1	5/1992

\* cited by examiner

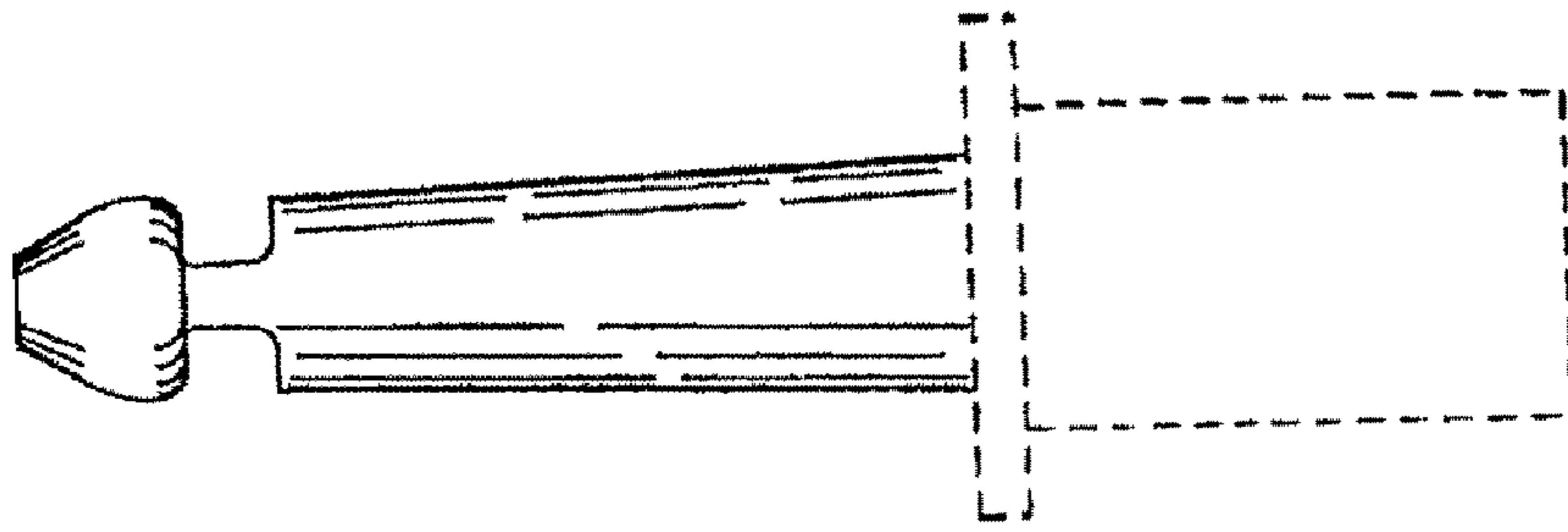

FIG. 1

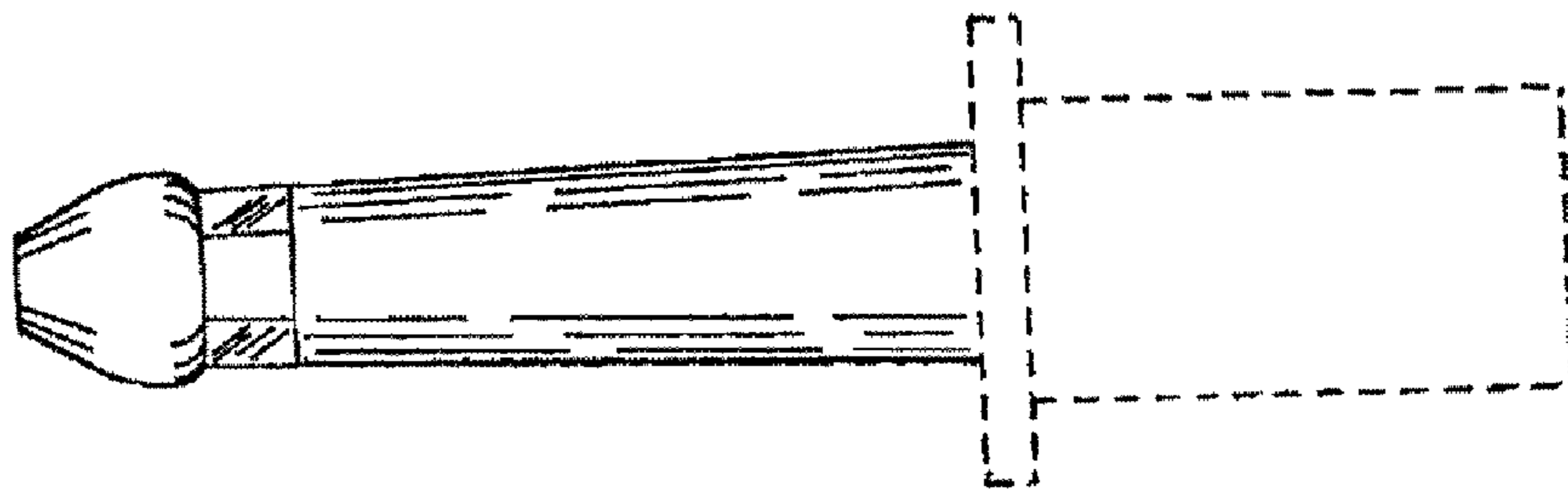

FIG. 2

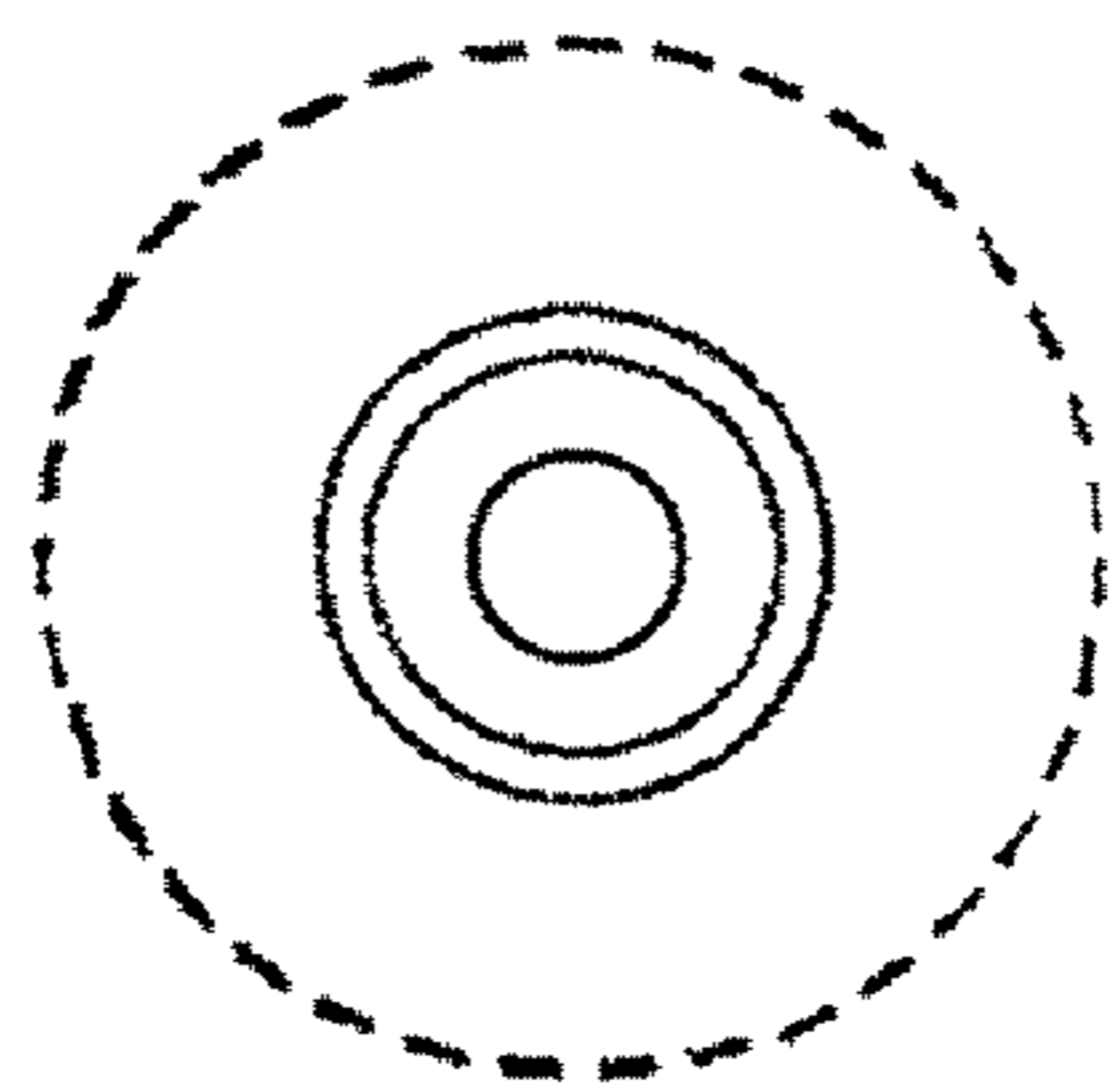

FIG. 3

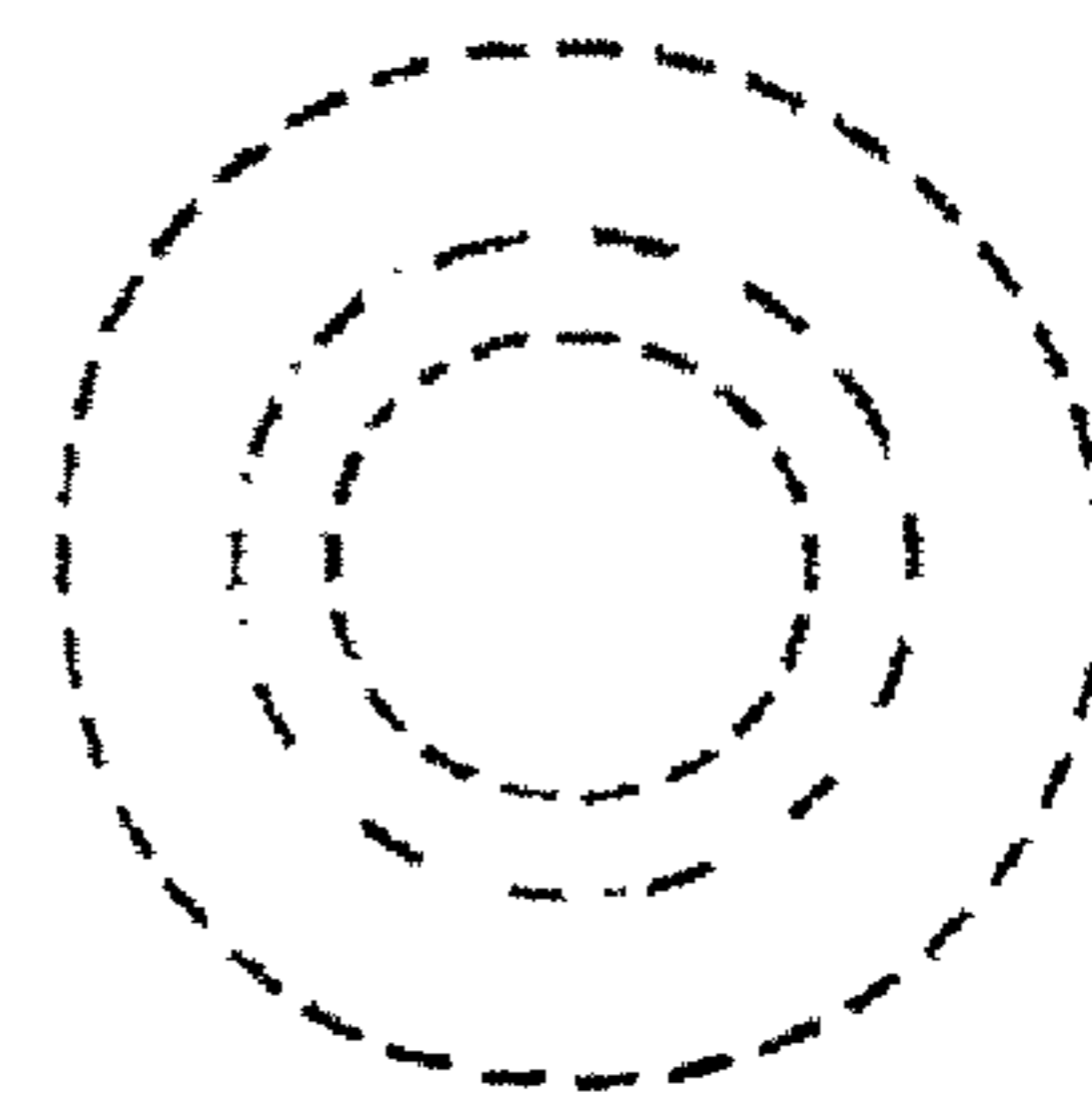

FIG. 4

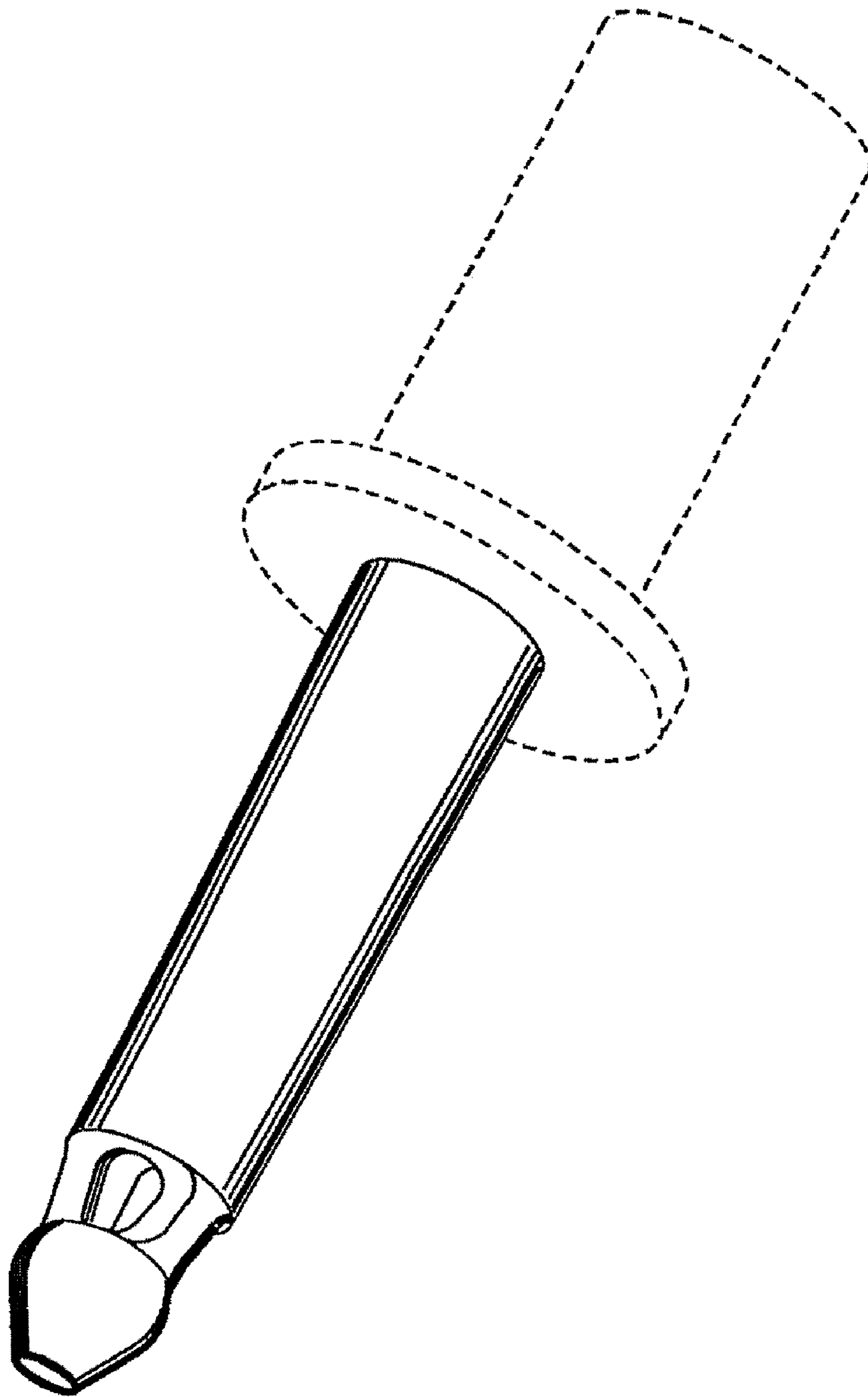

FIG. 5