



US00D635160S

(12) **United States Design Patent**  
**Berning et al.**

(10) **Patent No.:** **US D635,160 S**  
(45) **Date of Patent:** **\*\* Mar. 29, 2011**

(54) **BODY PANELS FOR A CONSTRUCTION MACHINE**

(75) Inventors: **Christian Berning**, Brühl (DE);  
**Thomas Kramer**, Königswinter (DE);  
**Cyrus Barimani**, Königswinter (DE);  
**Günter Hähn**, Königswinter (DE)

(73) Assignee: **Wirtgen GmbH** (DE)

(\*\*) Term: **14 Years**

(21) Appl. No.: **29/369,590**

(22) Filed: **Sep. 10, 2010**

(30) **Foreign Application Priority Data**

Mar. 19, 2010	(EM)	001683582-0001
Mar. 19, 2010	(EM)	001683582-0002
Mar. 19, 2010	(EM)	001683582-0003
Mar. 19, 2010	(EM)	001683582-0004
Mar. 19, 2010	(EM)	001683582-0005
Mar. 19, 2010	(EM)	001683582-0006
Mar. 19, 2010	(EM)	001683582-0007
Mar. 19, 2010	(EM)	001683582-0008
Mar. 19, 2010	(EM)	001683582-0009
Mar. 19, 2010	(EM)	001683582-0010
Mar. 19, 2010	(EM)	001683582-0011
Mar. 19, 2010	(EM)	001683582-0012
Mar. 19, 2010	(EM)	001683582-0013
Mar. 19, 2010	(EM)	001683582-0014
Mar. 19, 2010	(EM)	001683582-0015
Mar. 19, 2010	(EM)	001683582-0016
Mar. 19, 2010	(EM)	001683707-0001
Mar. 19, 2010	(EM)	001683707-0002
Mar. 19, 2010	(EM)	001683707-0003
Mar. 19, 2010	(EM)	001683707-0004
Mar. 19, 2010	(EM)	001683707-0005
Mar. 19, 2010	(EM)	001683707-0006
Mar. 19, 2010	(EM)	001683707-0007
Apr. 23, 2010	(EM)	001699323

(51) **LOC (9) Cl.** ..... **15-03**

(52) **U.S. Cl.** ..... **D15/33; D15/28**

(58) **Field of Classification Search** ..... D15/10,  
D15/13, 19, 22-26, 28, 33; 404/110, 101,  
404/108, 75, 102, 118, 84.05, 105  
See application file for complete search history.

(56) **References Cited**

**U.S. PATENT DOCUMENTS**

D135,005	S	*	2/1943	Baumgardner	.....	D15/10
3,000,277	A	*	9/1961	Crane et al.	.....	404/118
D239,966	S	*	5/1976	Swisher et al.	.....	D15/22
3,997,277	A	*	12/1976	Swisher et al.	.....	404/84.05

(Continued)

**OTHER PUBLICATIONS**

Berning et al., U.S. Appl. No. 29/369,586 for "Body Panels for a Construction Machine" filed Sep. 10, 2010. (not prior art).

(Continued)

*Primary Examiner* — Mark A Goodwin

(74) *Attorney, Agent, or Firm* — Wadley & Patterson, P.C.;  
Lucian Wayne Beavers

(57) **CLAIM**

What is claimed is the ornamental design for a body panels for a construction machine, as shown and described.

**DESCRIPTION**

FIG. 1 is a right rear perspective view of the body panels for a construction machine showing our new design. The area within the four sided broken line boundary on the top body panel in FIGS. 1, 2, and 6 form no part of the claimed design. The broken line showing of a construction machine in all the figures are for environmental purposes only and form no part of the claimed design.

FIG. 2 is a left rear perspective view thereof.

FIG. 3 is a right side elevation view thereof.

FIG. 4 is a left side elevation view thereof.

FIG. 5 is a rear elevation view thereof; and,

FIG. 6 is a top rear perspective view thereof.

**1 Claim, 6 Drawing Sheets**

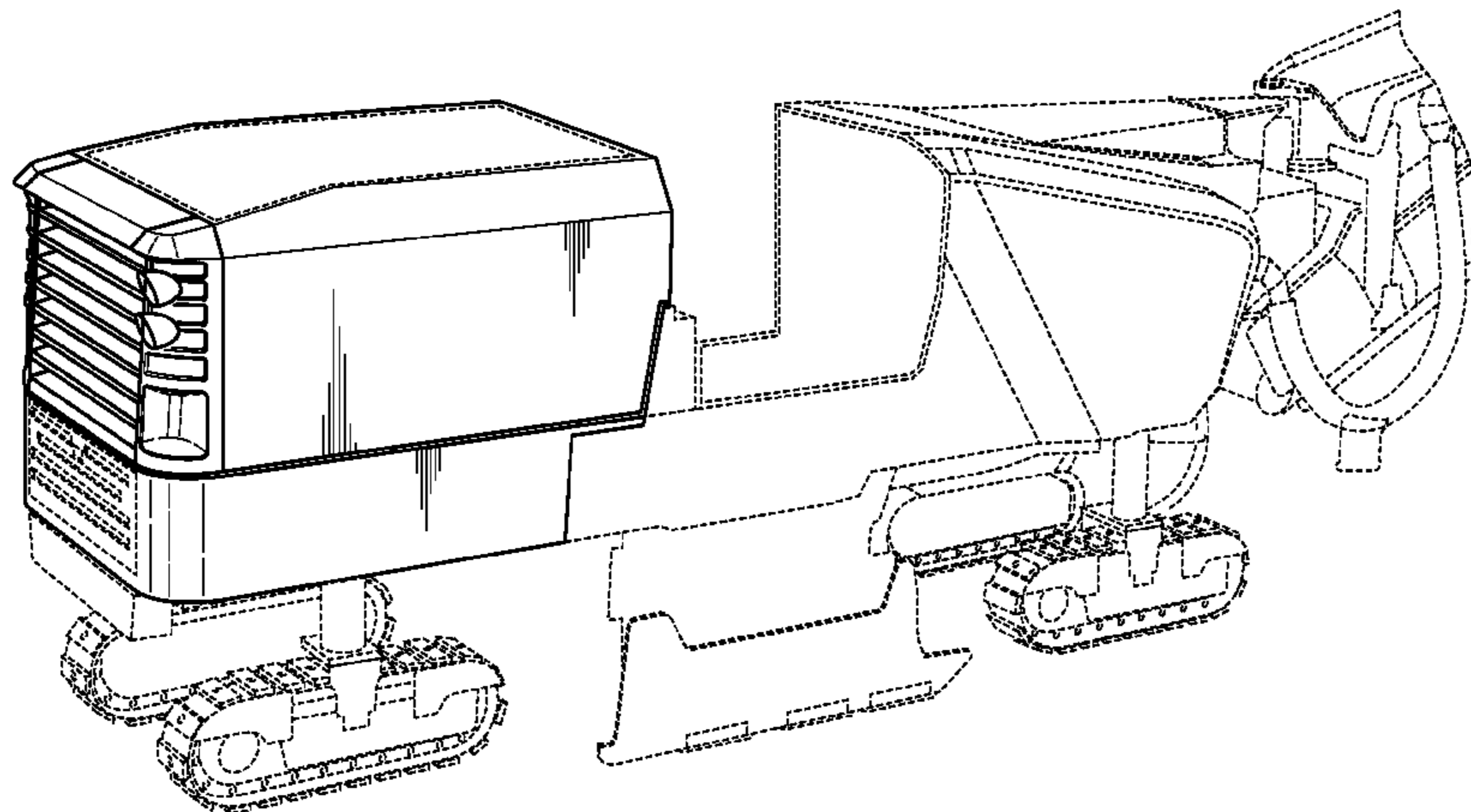

# US D635,160 S

Page 2

## U.S. PATENT DOCUMENTS

D258,887 S \* 4/1981 Swisher et al. .... D15/24  
4,325,580 A \* 4/1982 Swisher et al. .... 299/39.8  
D266,850 S \* 11/1982 Godbersen ..... D15/22  
4,938,537 A \* 7/1990 Rife et al. .... 299/39.6  
5,009,546 A \* 4/1991 Domenighetti et al. .... 404/110  
D323,511 S \* 1/1992 Swisher, Jr. .... D15/23  
5,190,398 A \* 3/1993 Swisher, Jr. .... 404/90  
5,201,603 A \* 4/1993 Bassett et al. .... 404/84.1  
5,201,604 A \* 4/1993 Ferguson et al. .... 404/110  
D362,449 S \* 9/1995 Swisher, Jr. .... D15/22  
5,511,900 A \* 4/1996 Macku ..... 404/84.1  
D370,917 S \* 6/1996 Swisher, Jr. .... D15/29  
5,615,973 A \* 4/1997 Campbell ..... 404/75  
5,722,789 A \* 3/1998 Murray et al. .... 404/90  
6,007,272 A \* 12/1999 Macku et al. .... 404/92  
6,071,040 A \* 6/2000 Macku et al. .... 404/108  
6,099,205 A \* 8/2000 Macku et al. .... 404/92  
6,193,437 B1 \* 2/2001 Heims ..... 404/110  
6,375,386 B1 \* 4/2002 Macku et al. .... 404/17  
D500,056 S \* 12/2004 DeYoung et al. .... D15/33

D526,336 S \* 8/2006 Maas et al. .... D15/28  
D527,393 S \* 8/2006 Maas et al. .... D15/28  
7,144,192 B2 \* 12/2006 Holl et al. .... 404/93  
D568,905 S \* 5/2008 Heusinger et al. .... D15/22  
D578,142 S \* 10/2008 Ewringmann ..... D15/22  
D599,825 S \* 9/2009 Schneider et al. .... D15/22  
D608,374 S \* 1/2010 De Rycke et al. .... D15/33  
D626,573 S \* 11/2010 Koetting et al. .... D15/22  
2006/0045624 A1 \* 3/2006 Nelson ..... 404/95  
2006/0198701 A1 \* 9/2006 Hall et al. .... 404/91  
2008/0152428 A1 \* 6/2008 Berning et al. .... 404/84.1

## OTHER PUBLICATIONS

Berning et al., U.S. Appl. No. 29/369,588 for "Body Panels for a Construction Machine" filed Sep. 10, 2010. (not prior art).  
Berning et al., U.S. Appl. No. 29/369,583 for "Body Panels for a Construction Machine" filed Sep. 10, 2010. (not prior art).  
Berning et al., U.S. Appl. No. 29/369,591 for "Cab for a Construction Machine" filed Sep. 10, 2010. (not prior art).

\* cited by examiner

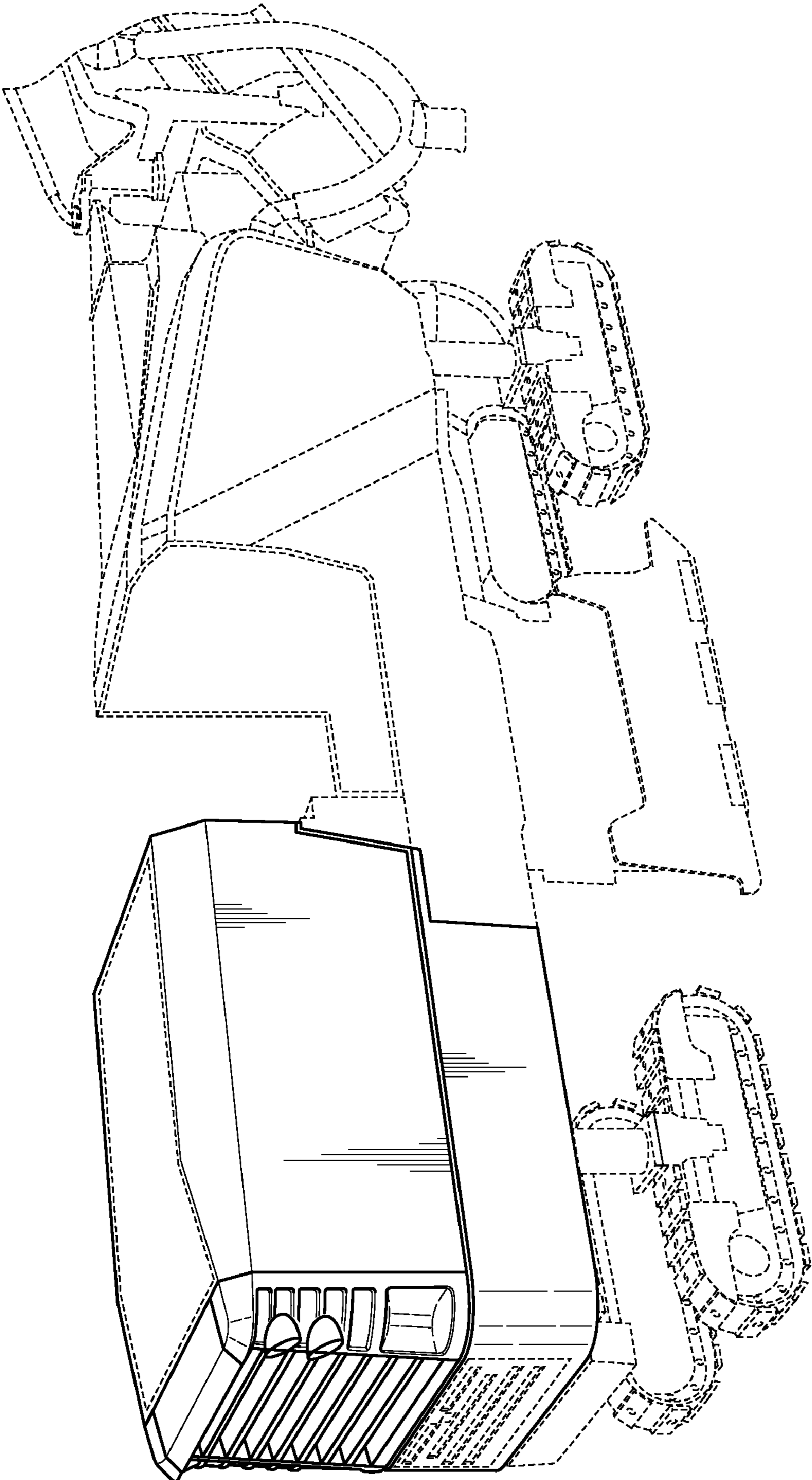

**FIG. 1**

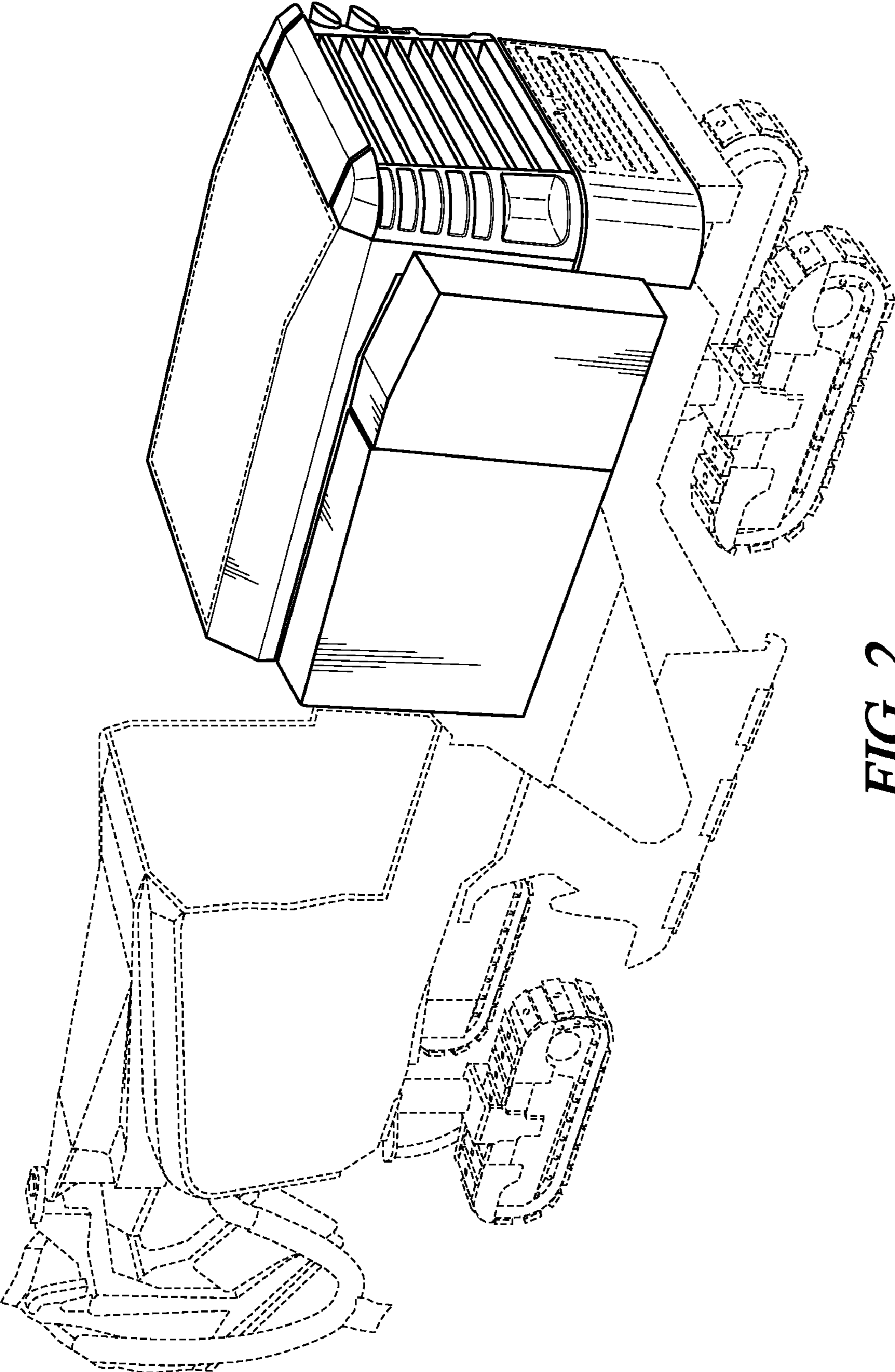

**FIG. 2**

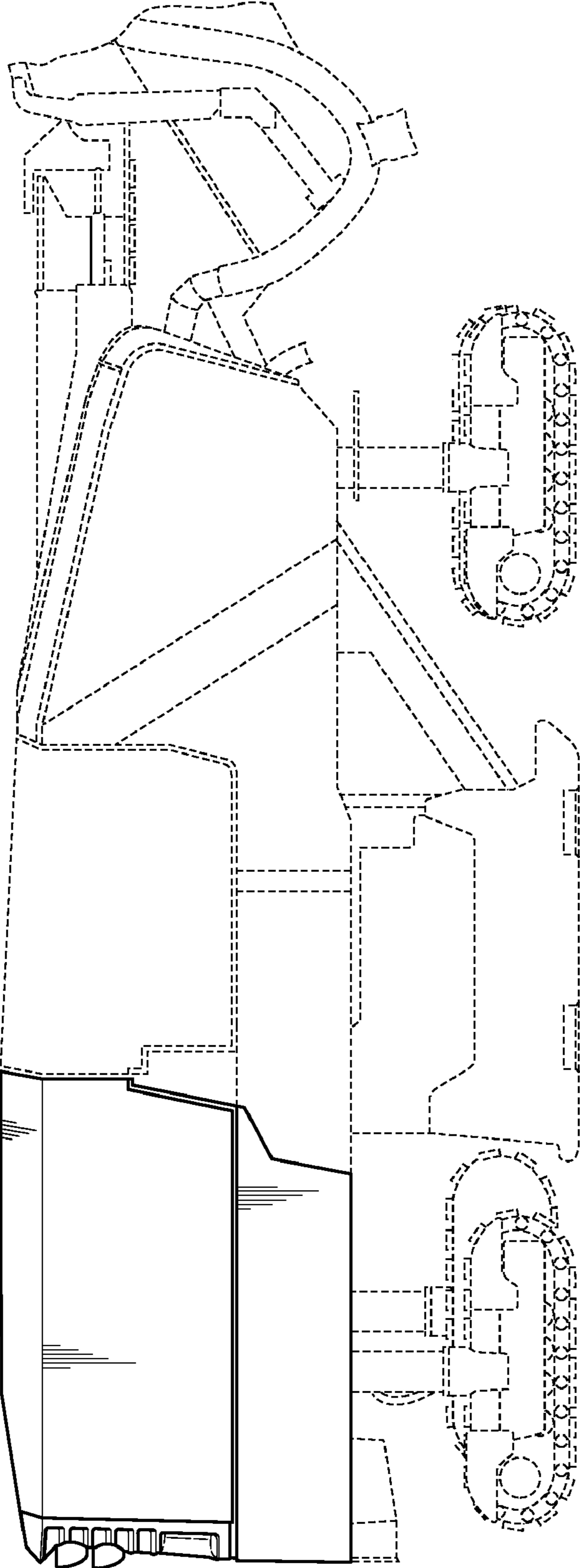

*FIG. 3*

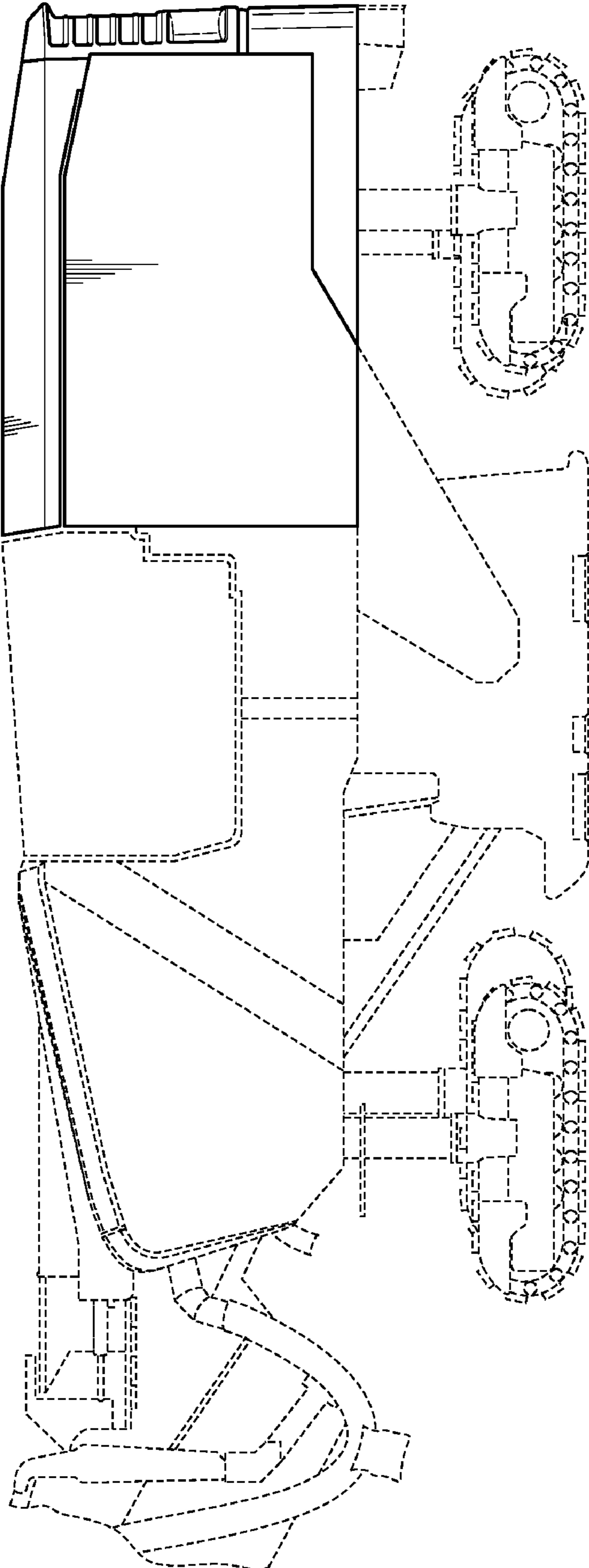

**FIG. 4**

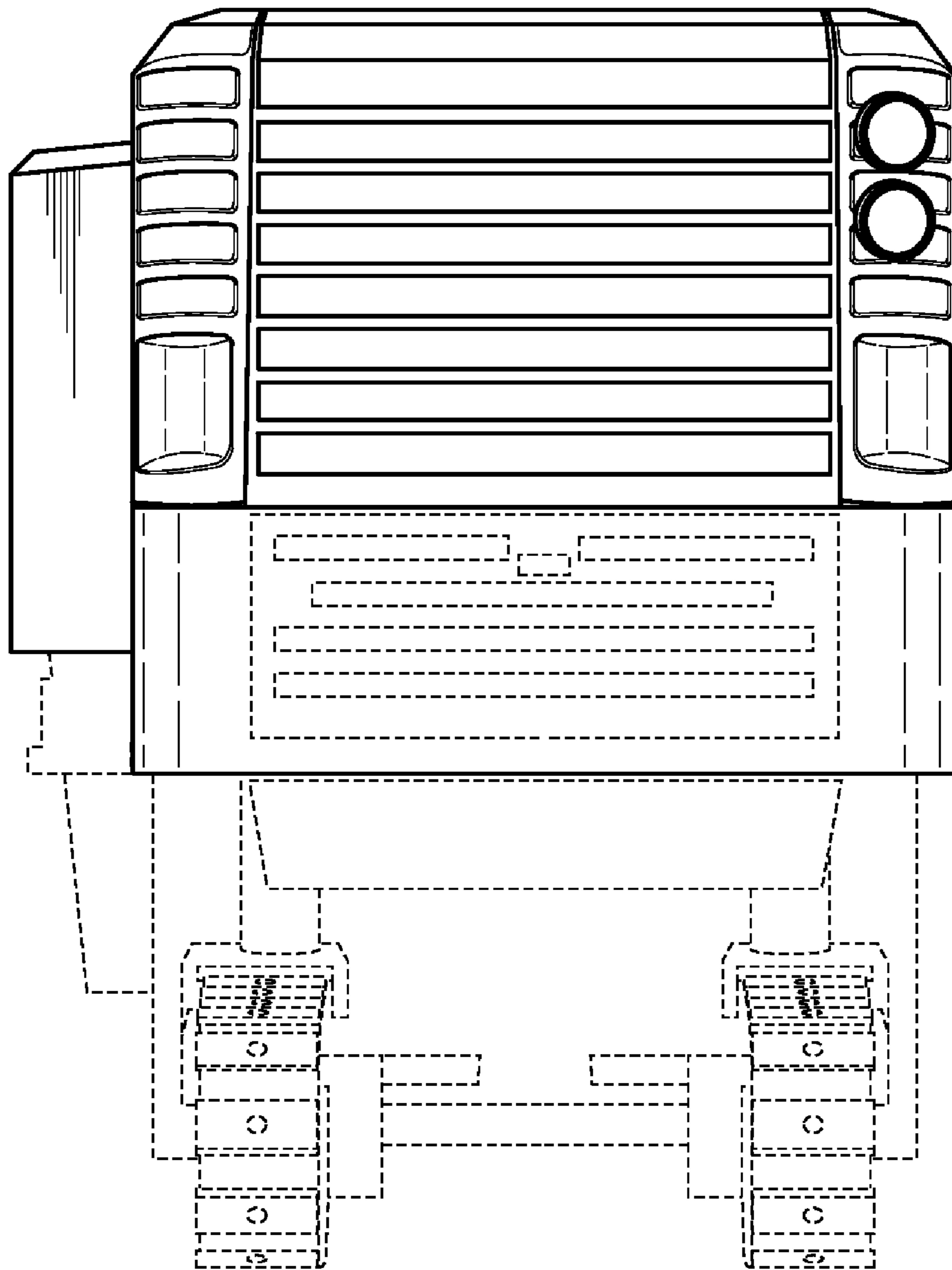

**FIG. 5**

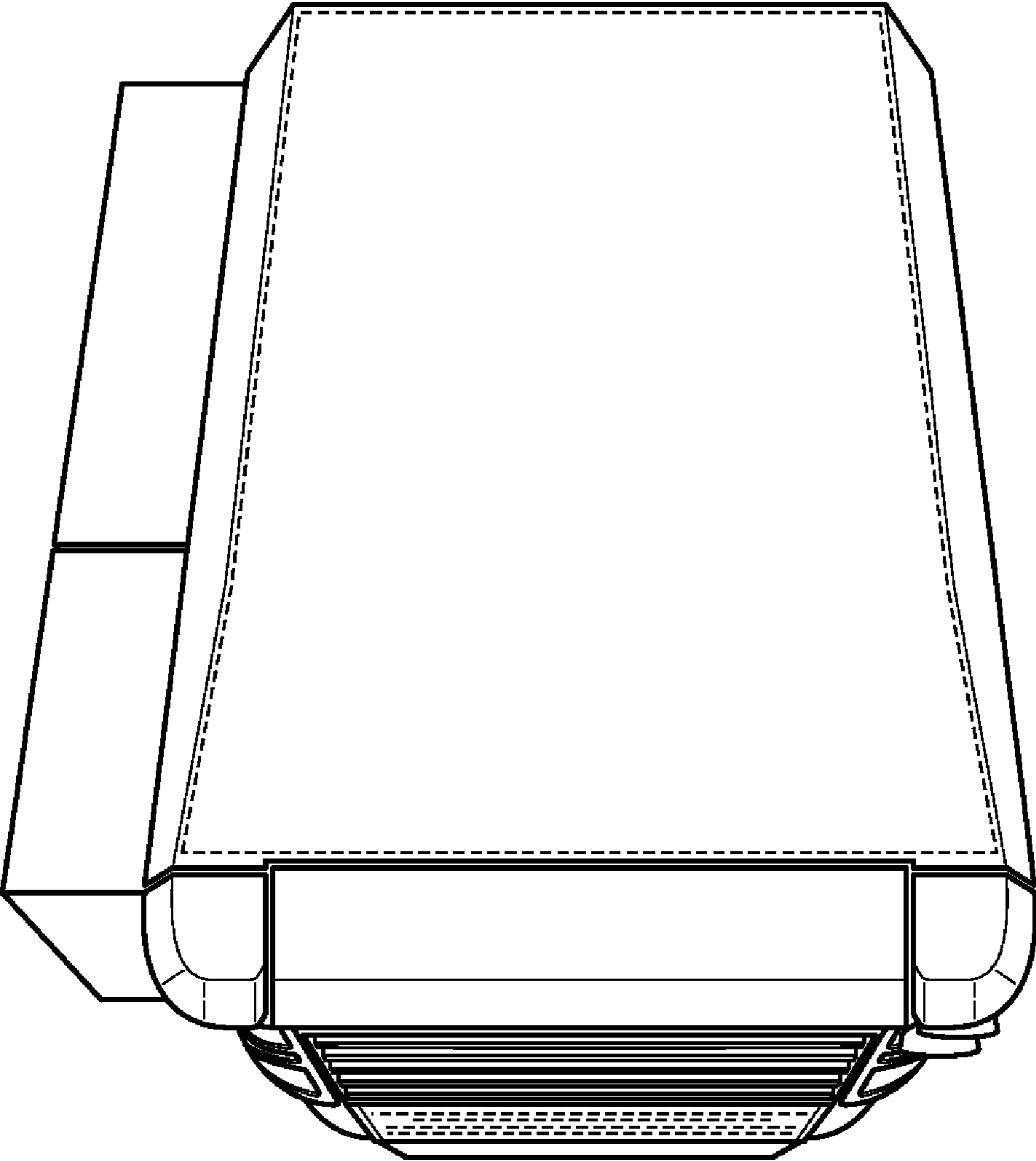

*FIG. 6*