



US00D635154S

(12) **United States Design Patent**
Rummer et al.

(10) **Patent No.:** **US D635,154 S**
(45) **Date of Patent:** **** Mar. 29, 2011**

(54) **REAR PORTION OF A MOTOR GRADER**

(75) Inventors: **Andrew Rummer**, Forsyth, IL (US);
Devraj Patkar, Decatur, IL (US);
Ashley Menges, Radnor, OH (US)

(73) Assignee: **Caterpillar Inc.**, Peoria, IL (US)

(**) Term: **14 Years**

(21) Appl. No.: **29/355,423**

(22) Filed: **Feb. 8, 2010**

(51) **LOC (9) Cl.** **15-03**

(52) **U.S. Cl.** **D15/28; D15/31; D15/33; D15/23**

(58) **Field of Classification Search** D15/10-12,
D15/19, 21-23, 28, 30-33; D21/537; 180/238,
180/264, 267, 420; 172/781-785, 788, 1,
172/776, 790, 430, 611, 792

See application file for complete search history.

(56) **References Cited**

U.S. PATENT DOCUMENTS

D184,216	S *	1/1959	Erlecher et al.	D15/23
D188,840	S *	9/1960	Beyer, Jr. et al.	D15/23
3,527,315	A *	9/1970	Hampton	180/238
3,858,661	A *	1/1975	Hallam et al.	172/1
3,889,976	A *	6/1975	Jesswein	280/400
D238,955	S *	2/1976	Peterson	D21/537
4,213,507	A *	7/1980	Horrer et al.	172/784
D275,107	S *	8/1984	Crabiel et al.	D15/25
4,535,860	A *	8/1985	Waggoner	180/24.05
4,679,634	A *	7/1987	Bulmahn	172/250
4,696,486	A *	9/1987	Ruhter	280/400
5,474,147	A *	12/1995	Yesel et al.	180/197
6,230,818	B1 *	5/2001	Slunder	172/789
D500,056	S *	12/2004	DeYoung et al.	D15/33
6,854,523	B2 *	2/2005	Takahashi	172/3
D541,826	S	5/2007	Brush et al.		
D548,752	S	8/2007	Merghani et al.		
D549,743	S	8/2007	Merghani et al.		
D557,711	S	12/2007	Merghani et al.		
D557,715	S	12/2007	Merghani et al.		

D559,869	S	1/2008	Kelley et al.		
D568,906	S	5/2008	Merghani et al.		
D593,582	S *	6/2009	Ono et al.	D15/23
D594,035	S *	6/2009	Ono et al.	D15/23
D594,479	S	6/2009	Greuel et al.		
D597,106	S	7/2009	Kelley et al.		
D624,565	S *	9/2010	Rummer et al.	D15/23
D624,566	S *	9/2010	Patkar et al.	D15/23
D624,567	S *	9/2010	Kelley	D15/33
D626,152	S *	10/2010	Patkar et al.	D15/23
D626,153	S *	10/2010	Gavin et al.	D15/31

(Continued)

OTHER PUBLICATIONS

CAT, 120M Motor Grader, Catalog, pp. 1-28, 2009, U.S.A.

(Continued)

Primary Examiner — Mark A Goodwin

(74) *Attorney, Agent, or Firm* — Michael D. Braunstein

(57) **CLAIM**

The ornamental design for a rear portion of a motor grader, as shown and described.

DESCRIPTION

FIG. 1 is a right, front perspective view of a rear portion of a motor grader showing our new design;
FIG. 2 is a right, rear perspective view thereof;
FIG. 3 is a left, front perspective view thereof;
FIG. 4 is a left, rear perspective view thereof;
FIG. 5 is a front view thereof;
FIG. 6 is a rear view thereof;
FIG. 7 is a right side view thereof;
FIG. 8 is a left side view thereof; and,
FIG. 9 is a top view thereof.

The broken lines of the figures showing additional portions of the motor grader are included for the purpose of illustrating environmental structure and form no part of the claimed design.

1 Claim, 8 Drawing Sheets

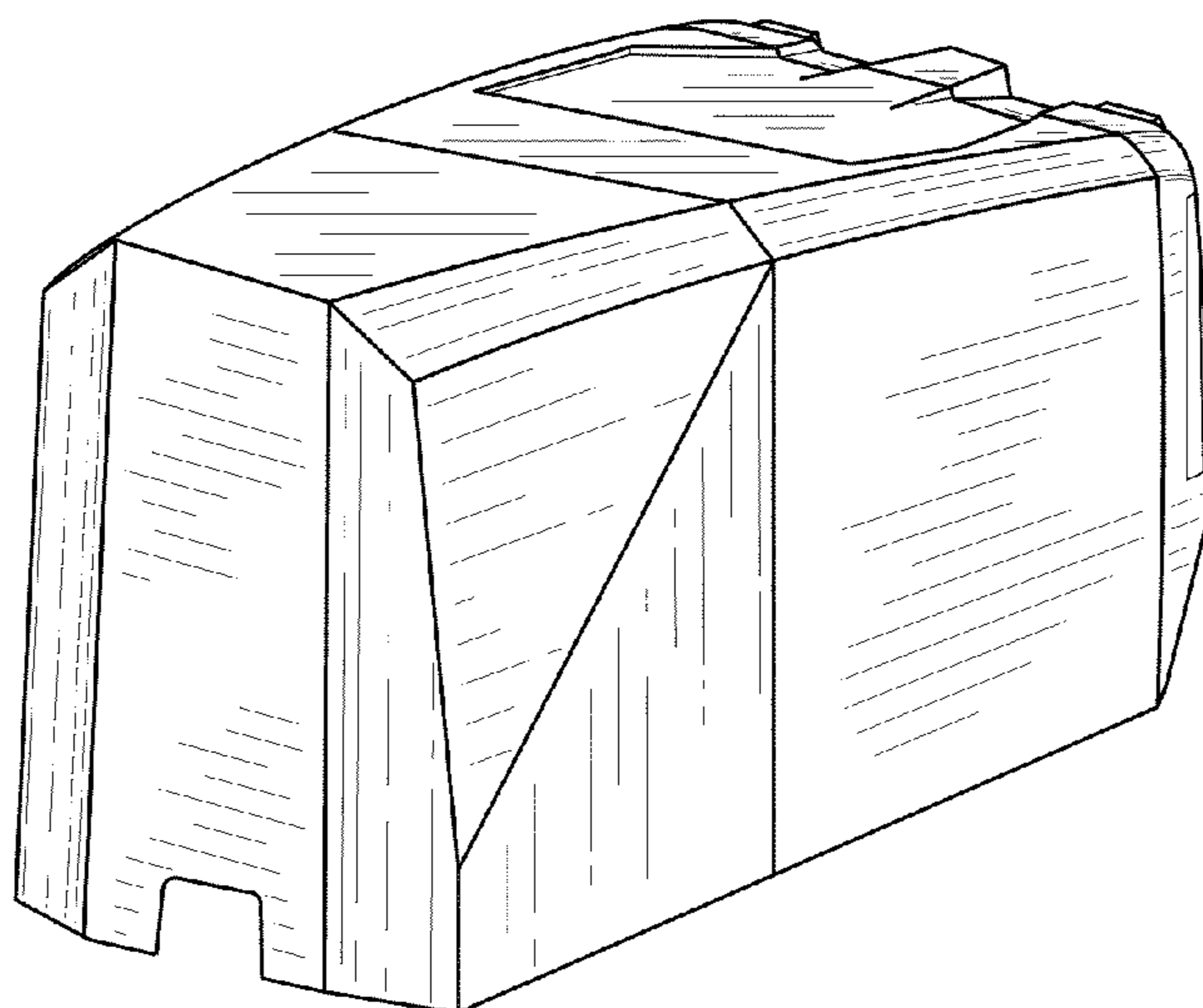

US D635,154 S

Page 2

U.S. PATENT DOCUMENTS

2002/0060081 A1* 5/2002 Mcgugan 172/4.5
2003/0221845 A1* 12/2003 Takahashi 172/3
2004/0149463 A1* 8/2004 Maeda et al. 172/297
2005/0252669 A1* 11/2005 LaReau et al. 172/776

OTHER PUBLICATIONS

CAT, 140M Motor Grader, Catalog, pp. 1-28, 2009, U.S.A.

* cited by examiner

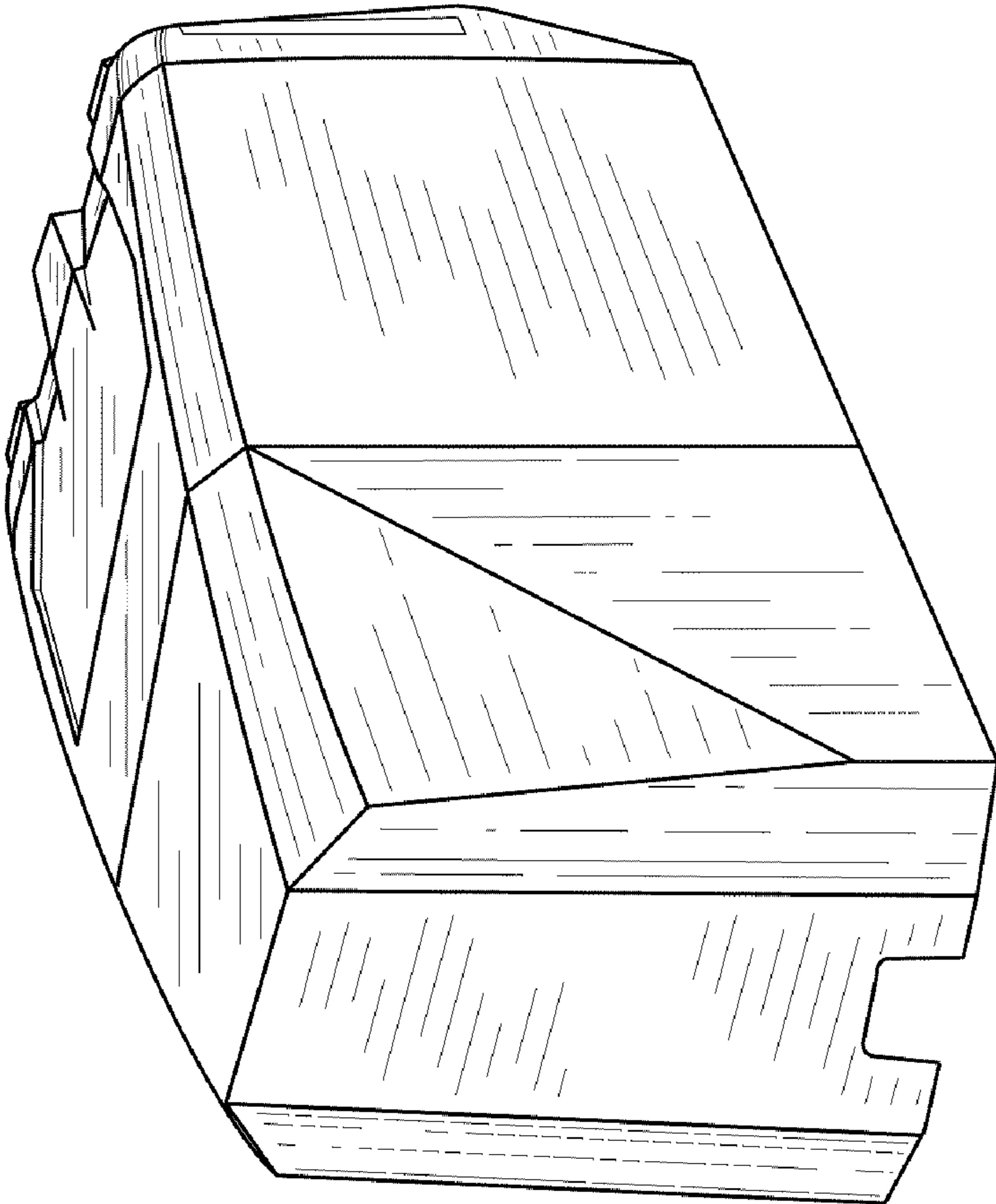

FIG. 1

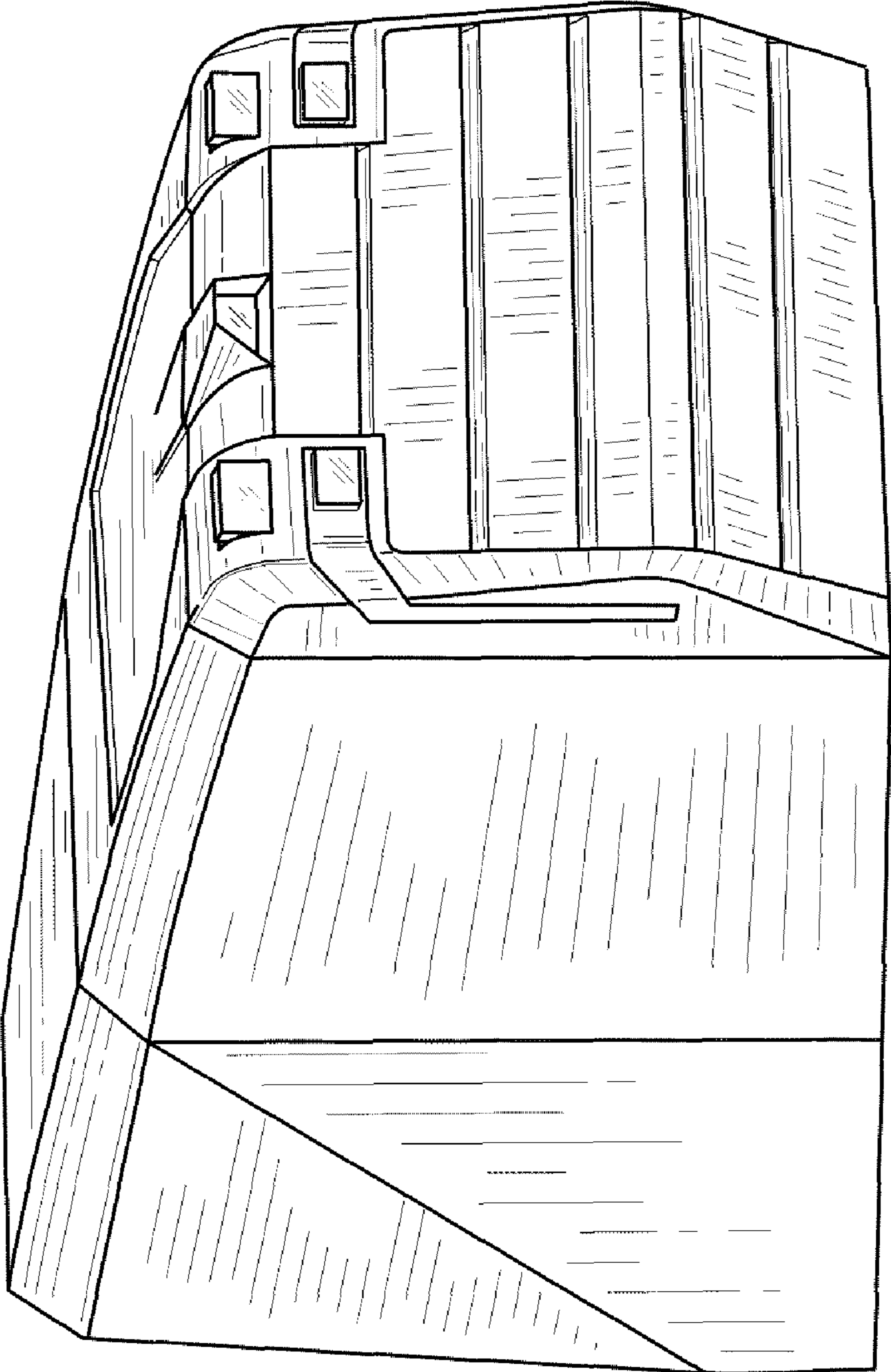

FIG. 2

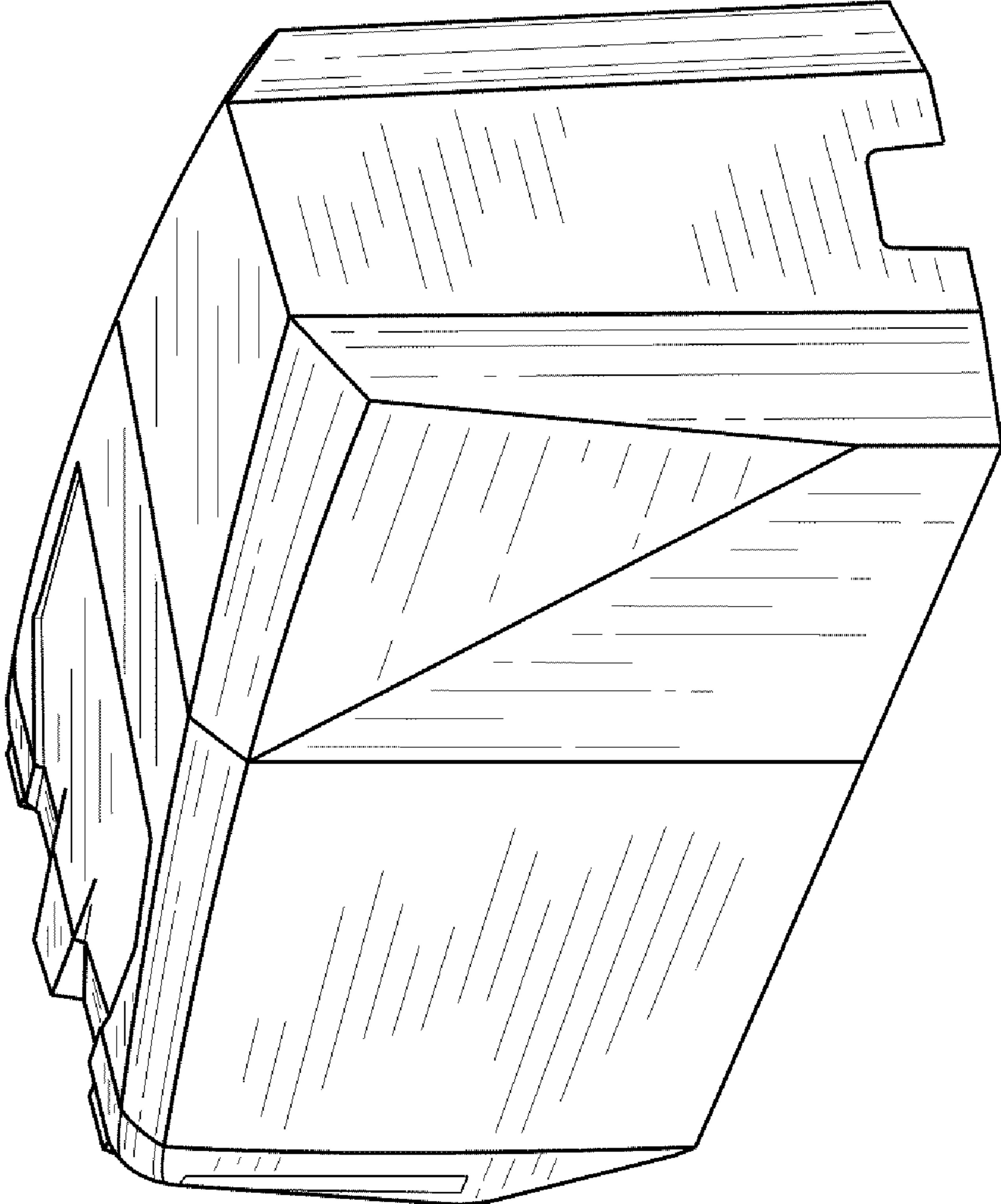

FIG. 3

FIG. 4

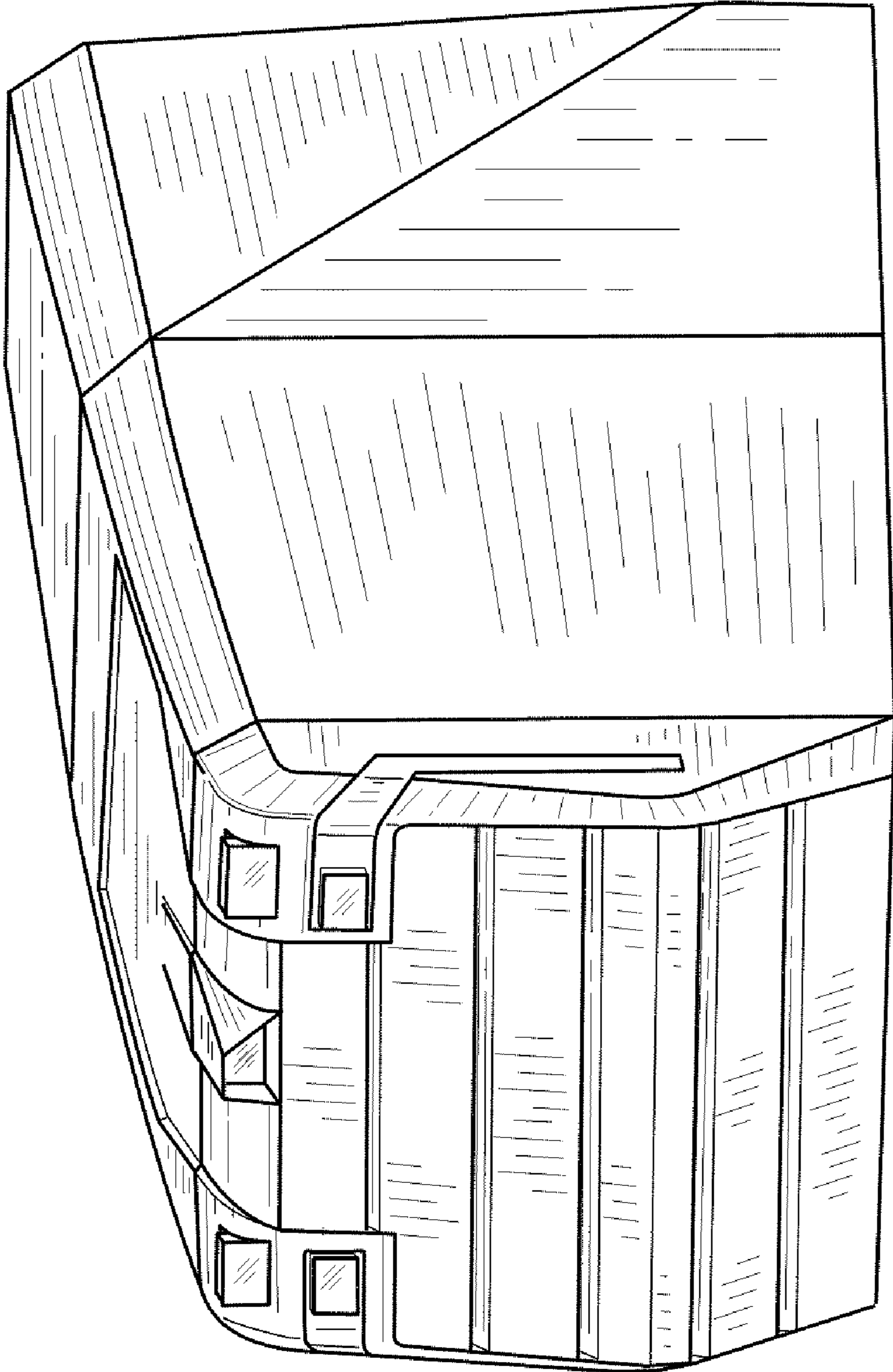

FIG. 5

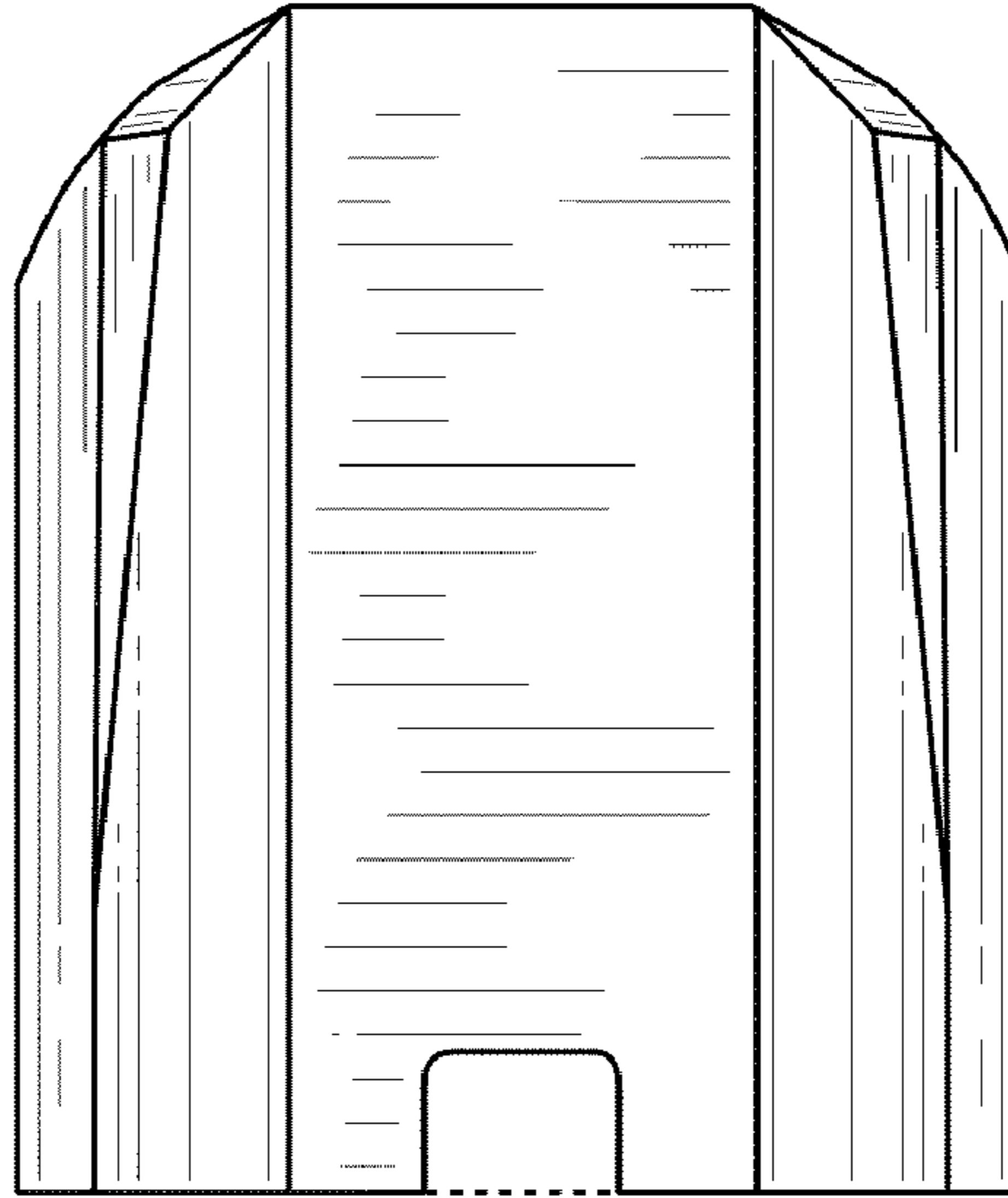
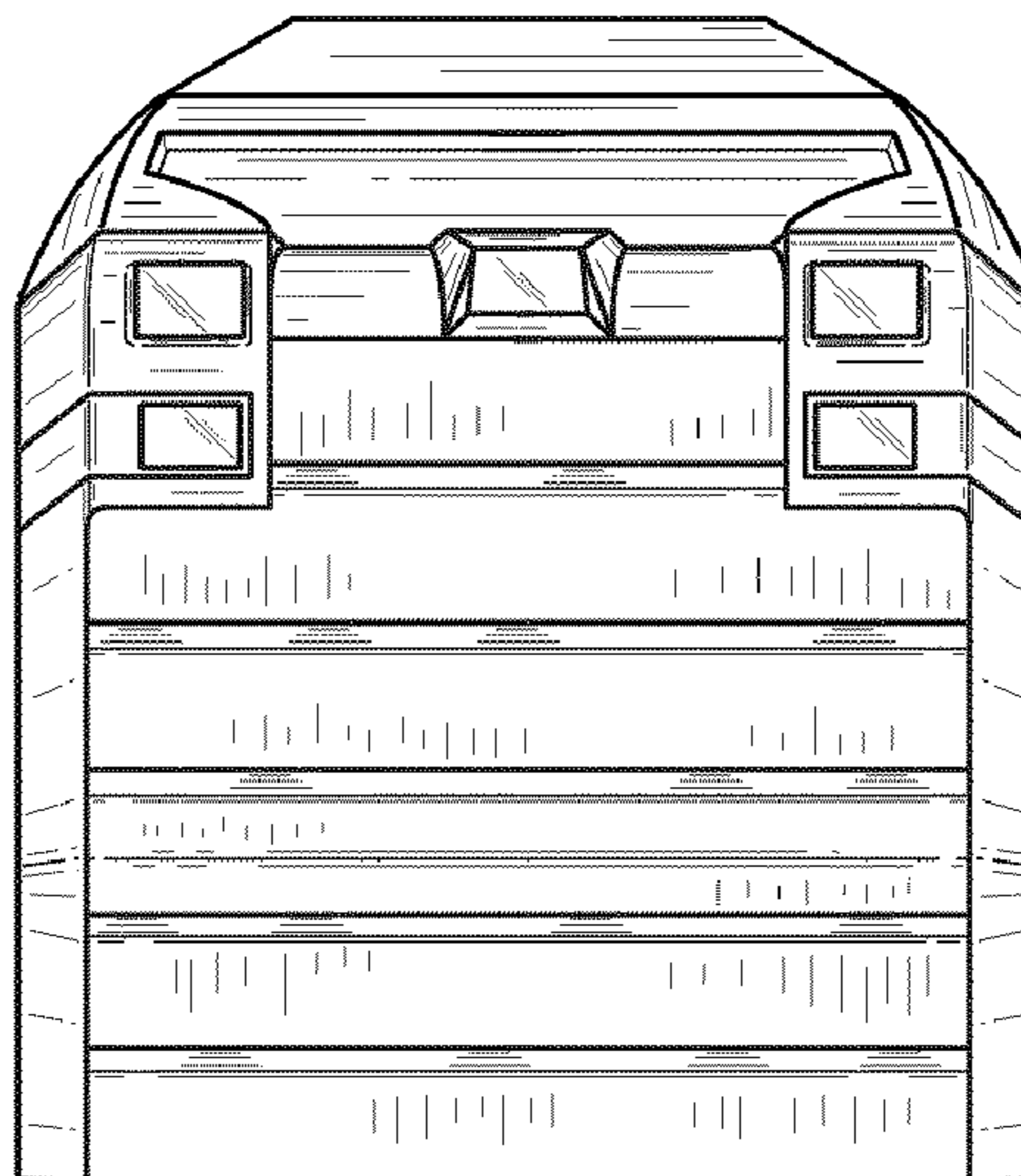

FIG. 6



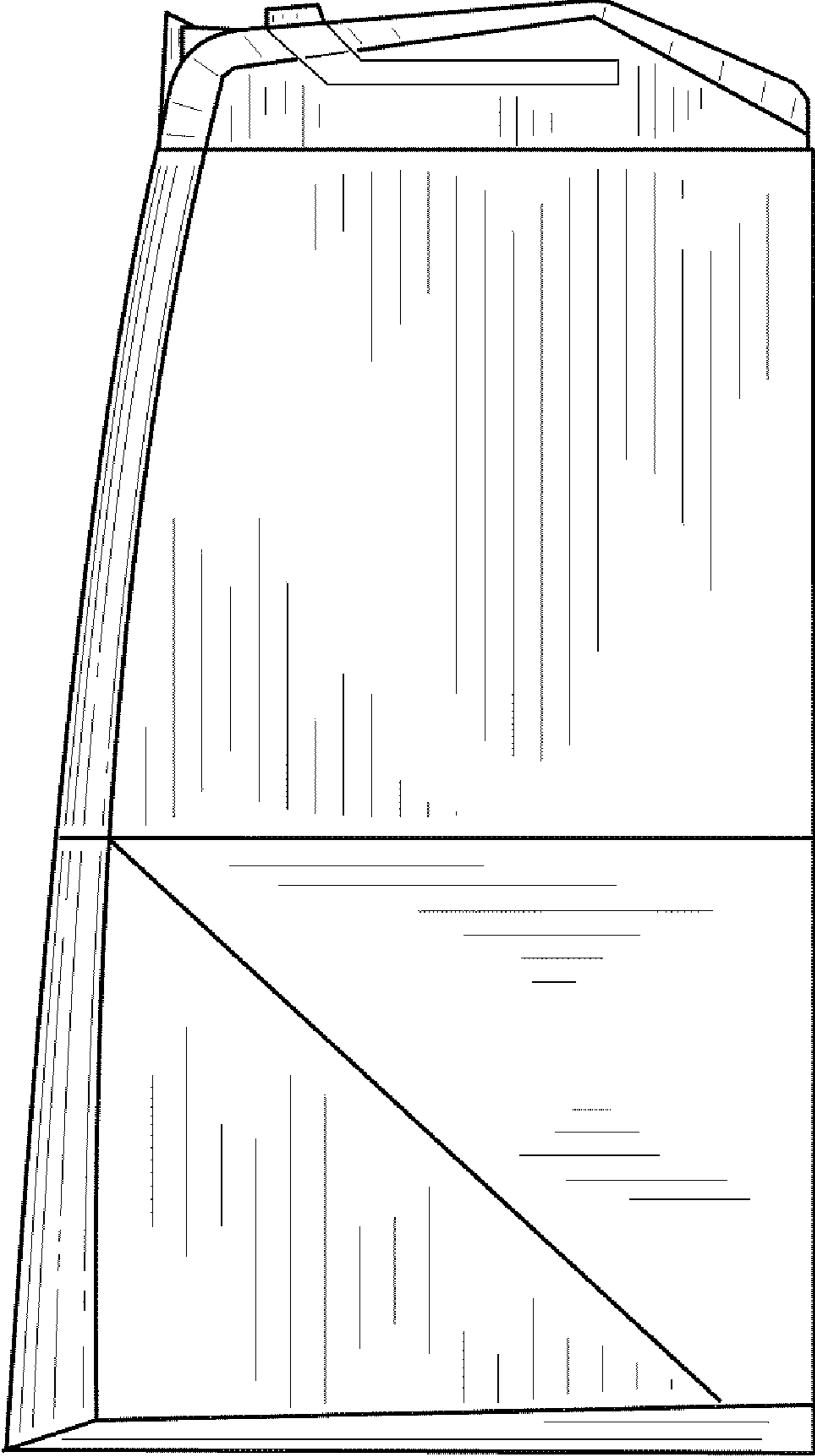

FIG. 7

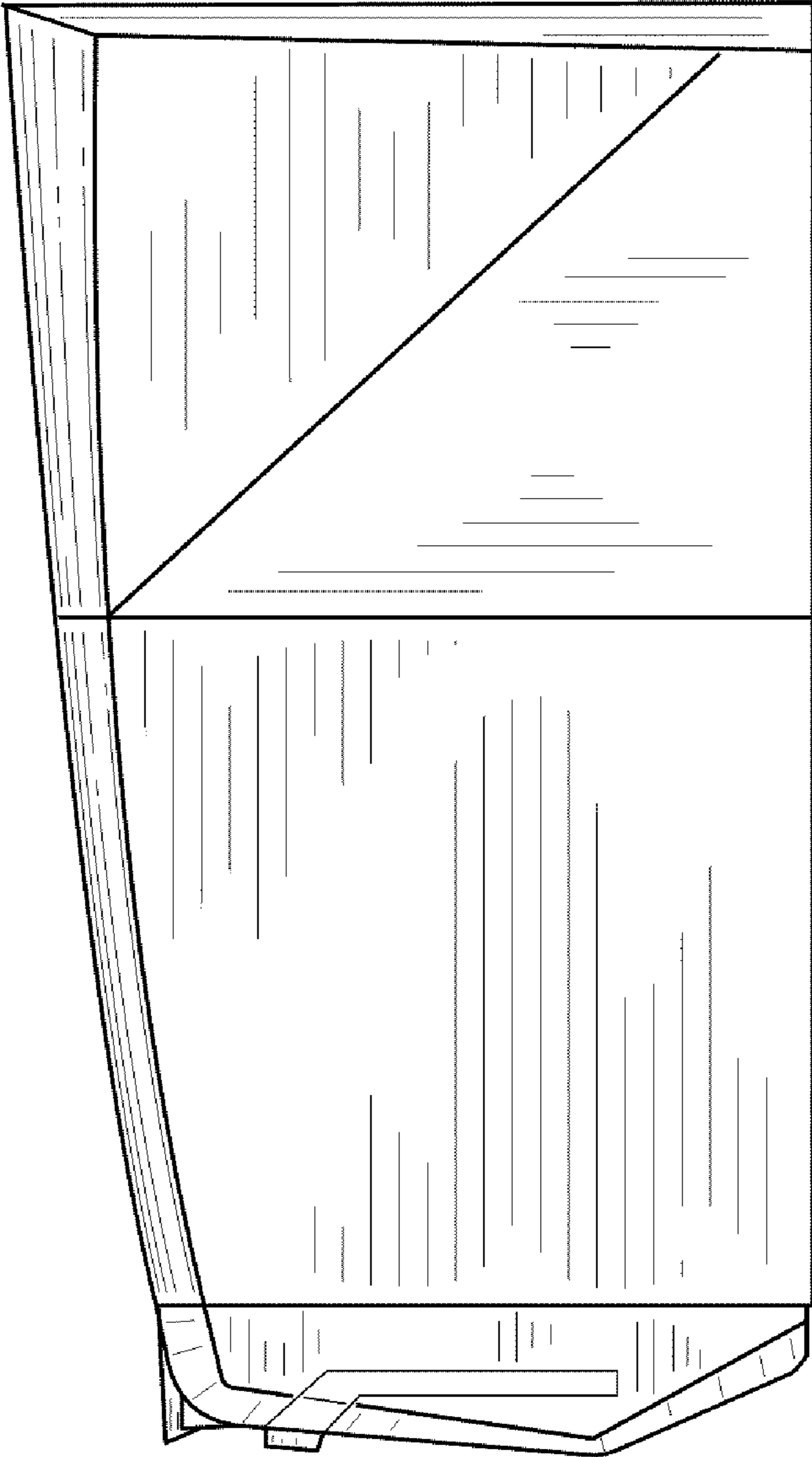

FIG. 8

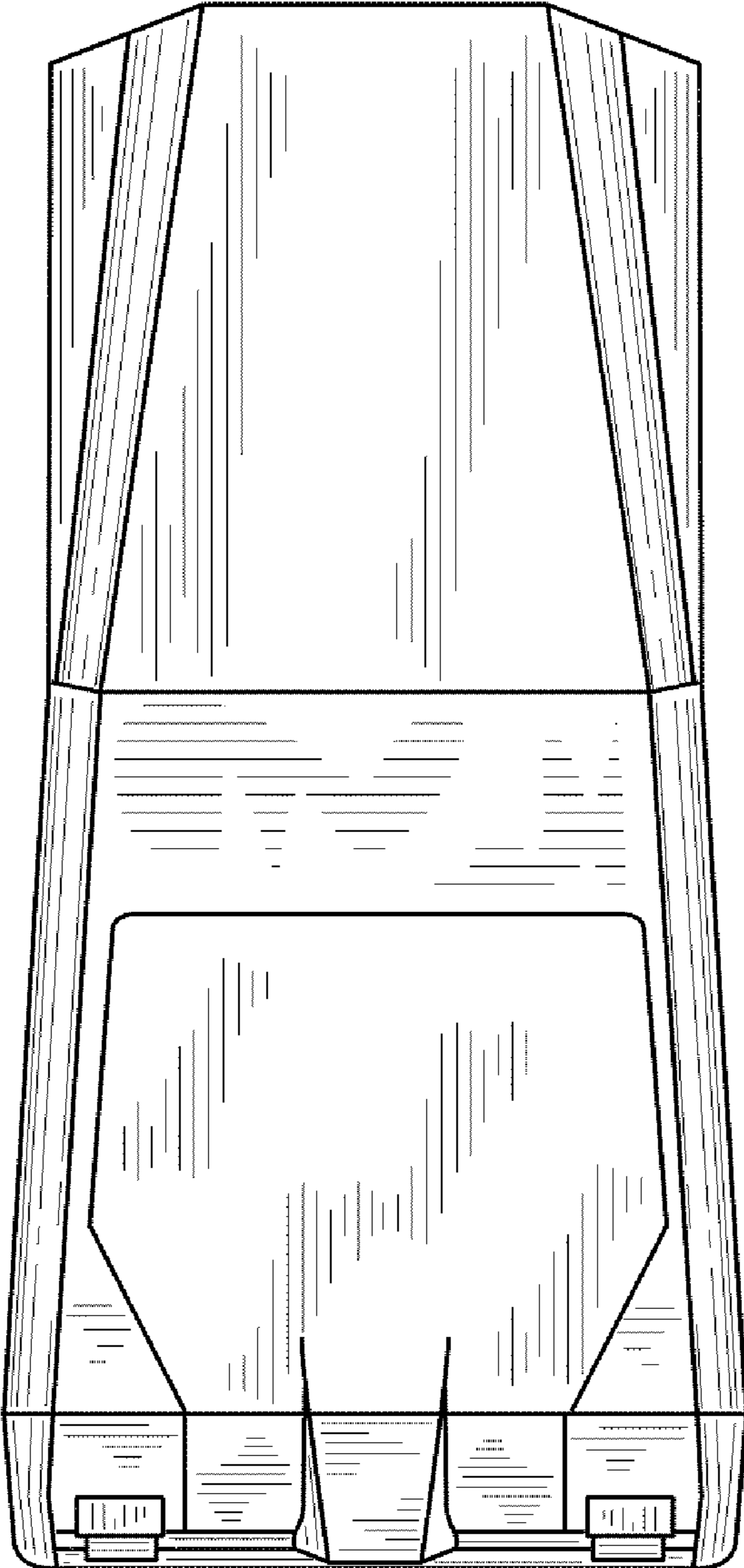

FIG. 9